

LeddarTech®

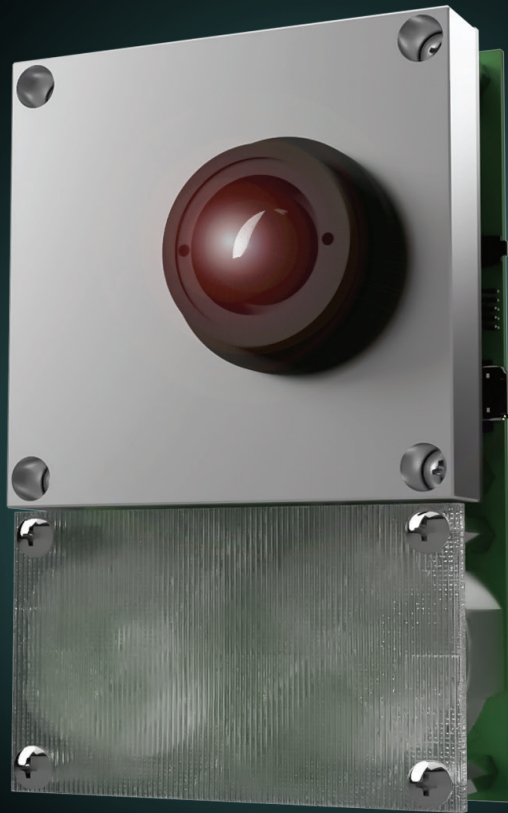

LEDDAR M16

MULTI-ELEMENT
SENSOR MODULE

LEDDAR M16

HIGH-PERFORMANCE, COST-EFFECTIVE, DETECTION AND RANGING FOR ANY ENVIRONMENT

MULTI-ELEMENT SENSOR MODULE

The Leddar® M16 Sensor Module is an advanced sensing solution that combines 16 independent active elements into a single sensor, resulting in rapid, continuous and accurate detection and ranging — including lateral discrimination — in the entire wide beam, without any moving parts. The Leddar M16 can be easily integrated to add sensing intelligence to almost any application, enabling developers and integrators to make the most of this cutting-edge technology while providing unmatched flexibility.

RECEIVER ASSEMBLY

The Leddar receiver includes 16 independent segments with simultaneous acquisition capabilities. Several beam options are available, ranging from 9° to 95° (see back page). The beam width and height depend on the selected beam option.

SOURCE AND CONTROL ASSEMBLY

The Leddar source and control assembly includes IR LED emitters with a dominant wavelength of 940 nm and incorporates the processing and I/O for the targeted applications. The source and control assembly beam matches the receiver assembly.

INTERFACES

A 3.81 mm x 8 pin male header is provided for interfacing through a cable harness or terminal block. A USB “Mini-B” connector is also provided for use with the Leddar® Software Development Kit, and a 2 x 20, 0.050” header is provided for custom expansion. Please contact the factory for specific interface requirements.

SOFTWARE DEVELOPMENT KIT (SDK)

The Leddar Enabler SDK provides a user-friendly application programming interface (API) with .Net and C libraries and code examples. Sample code for RS-485/MODBUS for both Windows and Linux, as well as LabVIEW and MATLAB integration examples, are also provided.

AMPLITUDE VS DISTANCE

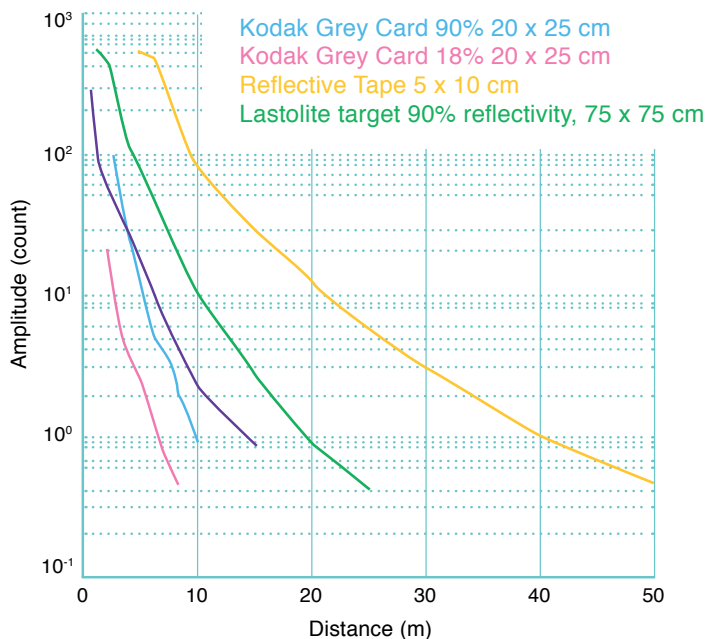

The chart above displays the detection amplitude of a 45° sensor for five reference objects (photography grey cards and reflective tape) of varying size and reflectivity.

LEDDAR M16

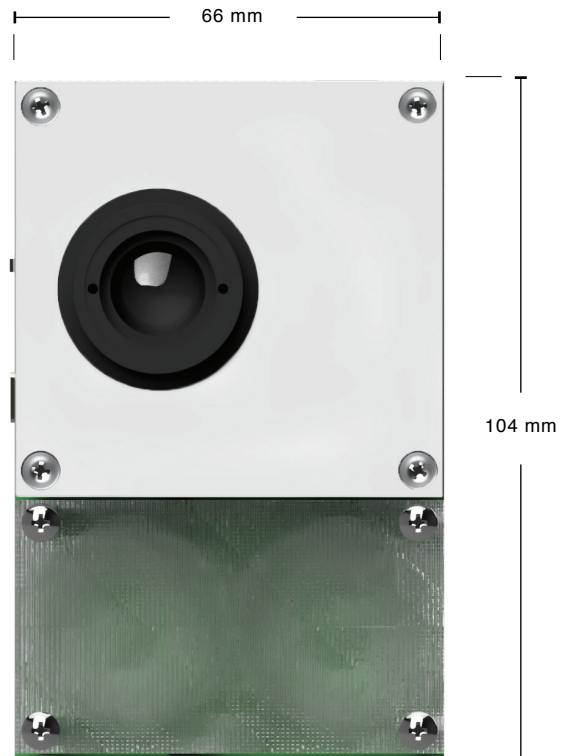
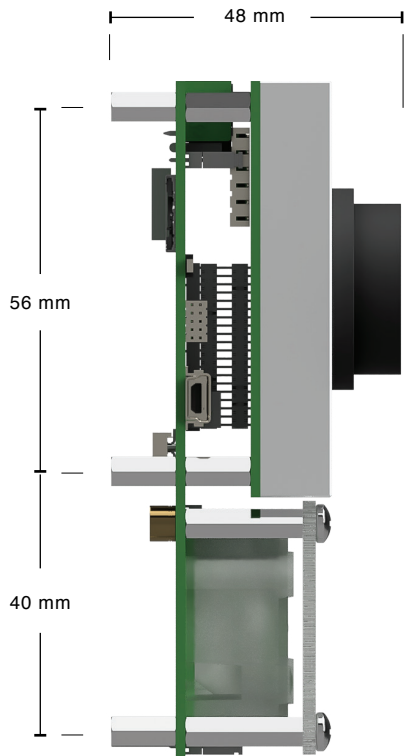

The module can be mounted from the back with six M3 machine screws.

CHARACTERISTICS

- **Beams** 9°, 18°, 24°, 34°, 45°, 95°
- **Interfaces** USB, RS-485, CAN, UART
- **Wavelength** 940 nm
- **Power supply** 12 or 24 VDC (jumper - selectable)
- **Dimensions** 104 mm x 66mm x 48mm¹
- **Weight** 180 g

¹ Apply to 45-degree model; different dimensions apply to other models, according to optics.

SYSTEM PERFORMANCE

- **Detection range** 0 to 100 meters (325 ft.)²
- **Accuracy** 5 cm
- **Data refresh rate** 6.25 Hz to 100 Hz³
- **Operating temperature range** -40°C to + 85°C
- **Meets IEC 62471 2006 criteria:** Exempt lamp classification
- **Distance precision** 6 mm
- **Distance resolution** 10 mm
- **Power consumption** 4 W

² Varies according to optics and target.

³ Depends on configuration.

HEIGHT AND WIDTH OF 45° BEAM OPTION

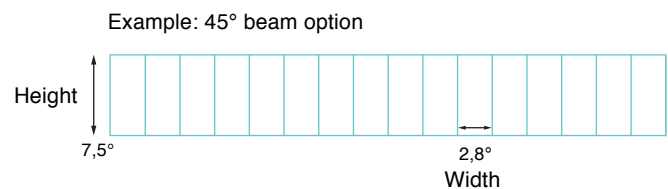

ORDERING INFORMATION

LED - MOD - XX - 10

□ Beam selection:
9°, 18°, 24°, 34°, 45°, 95°

□ Interfaces :
10 = USB, RS-485, CAN, UART

LEDDAR M16

**HIGH-PERFORMANCE, COST-EFFECTIVE,
DETECTION AND RANGING FOR ANY
ENVIRONMENT.**

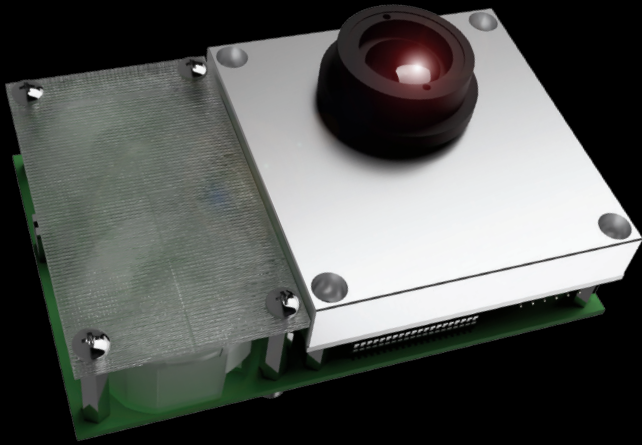

OVERVIEW

✓ Module Features

- 16 independent segments with simultaneous acquisition and lateral discrimination capabilities
- 9° to 95° beam options, for optimized field of view
- 0 to 100 meter detection range (325 ft.)
- Rapid data acquisition time up to 50 Hz

✓ Leddar M16 Benefits

- Proven reliability, even in harsh conditions
- Immune to ambient light
- No moving parts, for ultimate robustness
- Easy to integrate, includes Leddar Enabler SDK
- Low power consumption
- Best cost/performance ratio

LeddarTech HQ

4535 boul. Wilfrid-Hamel, Office 240
Quebec City (Quebec) G1P 2J7
Canada

Phone: 1-418-653-9000
Toll Free: 1-855-865-9900
Fax: 1-418-653-9099

leddartech.com

The content of this datasheet is subject to change without notice. Leddar™ is a registered trademark of LeddarTech Inc. Leddar® technology is covered by one or more of the following U.S. patents: 7,855,376 B2, 7,554,652, 8,319,949 B2, 8,310,655, 8,242,476, 8,908,159, 8,767,215 B2 or international equivalents. Other patents pending. The content of this datasheet is subject to change without notice. Find the most recent version of our datasheet on our website. Printed in Canada. Copyright LeddarTech Inc. © All rights reserved.

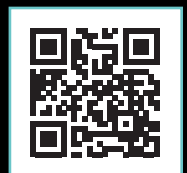

Компания «Life Electronics» занимается поставками электронных компонентов импортного и отечественного производства от производителей и со складов крупных дистрибьюторов Европы, Америки и Азии.

С конца 2013 года компания активно расширяет линейку поставок компонентов по направлению коаксиальный кабель, кварцевые генераторы и конденсаторы (керамические, пленочные, электролитические), за счёт заключения дистрибьюторских договоров

Мы предлагаем:

- Конкуренспособные цены и скидки постоянным клиентам.
- Специальные условия для постоянных клиентов.
- Подбор аналогов.
- Поставку компонентов в любых объемах, удовлетворяющих вашим потребностям.
- Приемлемые сроки поставки, возможна ускоренная поставка.
- Доставку товара в любую точку России и стран СНГ.
- Комплексную поставку.
- Работу по проектам и поставку образцов.
- Формирование склада под заказчика.
- Сертификаты соответствия на поставляемую продукцию (по желанию клиента).
- Тестирование поставляемой продукции.
- Поставку компонентов, требующих военную и космическую приемку.
- Входной контроль качества.
- Наличие сертификата ISO.

В составе нашей компании организован Конструкторский отдел, призванный помогать разработчикам, и инженерам.

Конструкторский отдел помогает осуществить:

- Регистрацию проекта у производителя компонентов.
- Техническую поддержку проекта.
- Защиту от снятия компонента с производства.
- Оценку стоимости проекта по компонентам.
- Изготовление тестовой платы монтаж и пусконаладочные работы.



Тел: +7 (812) 336 43 04 (многоканальный)

Email: org@lifeelectronics.ru