



SOT-23



Pin Definition:

1. Reference
2. Cathode
3. Anode

TO-92



Pin Definition:

1. Reference
2. Anode
3. Cathode

General Description

TS432 series is a three-terminal adjustable shunt regulator with specified thermal stability. The output voltage may be set to any value between V_{REF} (approximately 1.24V) and 18V with two external resistors. TS432 series has a typical output impedance of 0.05Ω . Active output circuitry provides a very sharp turn-on characteristic, making TS432 series excellent replacement for zener diode in many applications.

Features

- Precision Reference Voltage
TS432A – $1.24V \pm 1\%$
TS432B – $1.24V \pm 0.5\%$
- Minimum Cathode Current for Regulation: $20\mu A$ (typ.)
- Equivalent Full Range Temp. Coefficient: $50\text{ppm}/^\circ\text{C}$
- Programmable Output Voltage up to 18V
- Fast Turn-On Response
- Sink Current Capability of $80\mu A$ to 100mA
- Low Dynamic Output Impedance: 0.05Ω
- Low Output Noise
- Halogen Free Available

Applications

- Voltage Monitor
- Delay Timer
- Constant –Current Source/Sink
- High-Current Shunt Regulator
- Crow Bar
- Over-Voltage / Under-Voltage Protection

Ordering Information

Part No.	Package	Packing
TS432xCX RFG	SOT-23	3,000pcs / 7" Reel
TS432xCT B0G	TO-92	1,000pcs / Bulk
TS432xCT A3G	TO-92	2,000pcs / Ammo

Note: Where **x** denotes voltage tolerance

A: $\pm 1\%$, **B:** $\pm 0.5\%$

"G" denotes for Halogen free products

Block Diagram

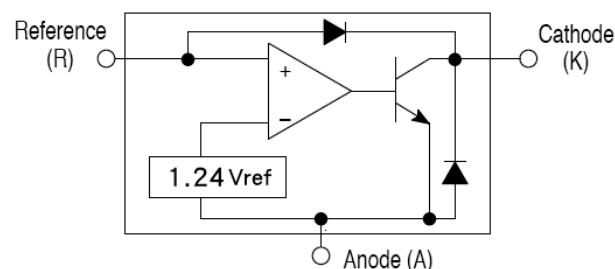

Absolute Maximum Ratings ($T_A=25^\circ\text{C}$ unless otherwise noted)

Parameter	Symbol	Limit	Unit
Cathode Voltage (Note 1)	V_{KA}	18	V
Continuous Cathode Current Range	I_K	100	mA
Reference Input Current Range	I_{REF}	3	mA
Power Dissipation	P_D	0.35	W
Junction Temperature	T_J	+150	$^\circ\text{C}$
Operation Temperature Range	T_{OPER}	0 ~ +70	$^\circ\text{C}$
Storage Temperature Range	T_{STG}	-65 ~ +150	$^\circ\text{C}$

Note 1: Voltage values are with respect to the anode terminal unless otherwise noted.



Recommended Operating Condition

Parameter	Symbol	Limit	Unit
Cathode Voltage ^(Note 1)	V_{KA}	16	V
Continuous Cathode Current Range	I_K	100	mA

Electrical Characteristics ($T_A=25^\circ\text{C}$ unless otherwise noted)

Parameter	Symbol	Test Conditions	Min	Typ	Max	Unit
Reference voltage	V_{REF}	$V_{KA}=V_{REF}, I_K=10\text{mA}$ (Figure 1)	1.227	1.240	1.252	V
			1.233		1.246	
Deviation of reference input voltage	ΔV_{REF}	$V_{KA}=V_{REF}, I_K=10\text{mA}$ $T_A=$ full range (Figure 1)	--	10	25	mV
Ratio of change in Vref to change in cathode Voltage	$\Delta V_{REF}/\Delta V_{KA}$	$I_{KA}=10\text{mA}, V_{KA}=16\text{V to } V_{REF}$ (Figure 2)	--	-1.0	-2.7	mV/V
Reference Input current	I_{REF}	$R1=10\text{K}\Omega, R2=\infty, I_{KA}=10\text{mA}$ $T_A=$ full range (Figure 2)	--	0.25	0.5	μA
Deviation of reference input current, over temp.	ΔI_{REF}	$R1=10\text{K}\Omega, R2=\infty, I_{KA}=10\text{mA}$ $T_A=$ full range (Figure 2)	--	0.04	0.8	μA
Off-state Cathode Current	$I_{KA}(\text{off})$	$V_{REF}=0\text{V}$ (Figure 3), $V_{KA}=16\text{V}$	--	0.125	0.5	μA
Dynamic Output Impedance	$ Z_{KA} $	$f<1\text{KHZ}, V_{KA}=V_{REF}$ $I_{KA}=1\text{mA to } 100\text{mA}$ (Figure 1)	--	0.2	0.4	Ω
Minimum Operating Cathode Current	$I_{KA(\text{MIN})}$	$V_{KA}=V_{REF}$ (Figure 1)	--	20	80	μA

* The deviation parameters ΔV_{REF} and ΔI_{REF} are defined as difference between the maximum value and minimum value

Obtained over the full operating ambient temperature range that applied.

* The average temperature coefficient of the reference input voltage, αV_{REF} is defined as:

$$\alpha V_{ref} \left(\frac{\text{ppm}}{^\circ\text{C}} \right) = \frac{\left(\frac{\Delta V_{ref}}{V_{ref}} \right) \times 10^6}{\Delta T_A} \quad \left(T_A = 25^\circ\text{C} \right)$$

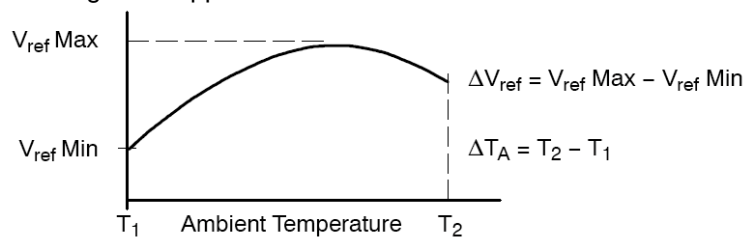

Where: T_2-T_1 = full temperature change.

αV_{REF} can be positive or negative depending on whether V_{REF} Min. or V_{REF} Max occurs at the lower ambient temperature. Example: $\Delta V_{REF}=7.2\text{mV}$ and the slope is positive, $V_{REF}=1.241\text{V}$ at 25°C , $\Delta T=125^\circ\text{C}$

$$\alpha V_{ref} \left(\frac{\text{ppm}}{^\circ\text{C}} \right) = \frac{0.0072 \times 10^6}{125} = 46 \text{ ppm}/^\circ\text{C}$$

* The dynamic impedance Z_{KA} is defined as:

$$|Z_{KA}| = \frac{\Delta V_{KA}}{\Delta I_K}$$

* When the device operating with two external resistors, $R1$ and $R2$, (refer to Figure 2) the total dynamic impedance of the circuit is given by:

$$|Z_{KA}'| = |Z_{KA}| \times \left(1 + \frac{R1}{R2} \right)$$

Test Circuits

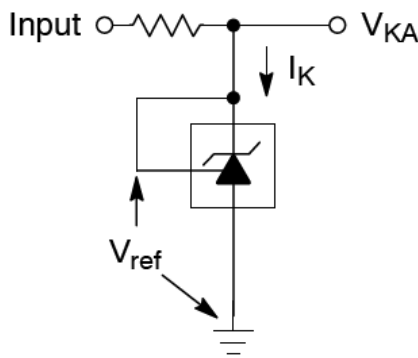
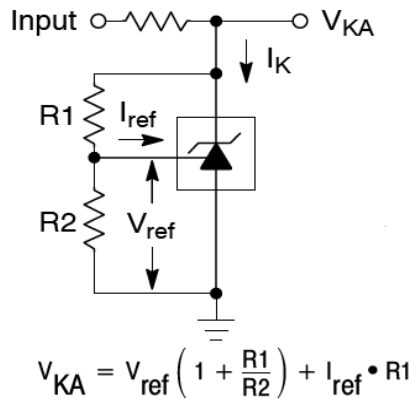

Figure 1: $V_{KA} = V_{REF}$



$$V_{KA} = V_{ref} \left(1 + \frac{R1}{R2} \right) + I_{ref} \cdot R1$$

Figure 2: $V_{KA} > V_{REF}$

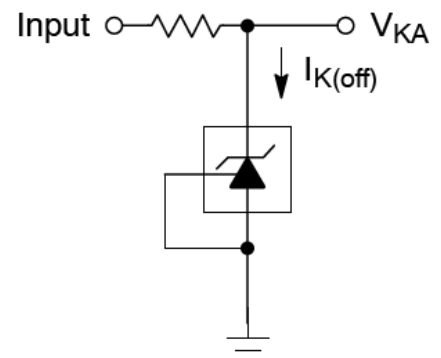

Figure 3: Off-State Current

Additional Information – Stability

When TS432 series is used as a shunt regulator, there are two options for selection of C_L , are recommended for optional stability:

- A) No load capacitance across the device, decouple at the load.
- B) Large capacitance across the device, optional decoupling at the load.

The reason for this is that TS432 series exhibits instability with capacitances in the range of 10nF to 1 μ F (approx.) at light cathode current up to 3mA(typ). The device is less stable the lower the cathode voltage has been set for. Therefore while the device will be perfectly stable operating at a cathode current of 10mA (approx.) with a 0.1 μ F capacitor across it, it will oscillate transiently during start up as the cathode current passes through the instability region. Select a very low capacitance, or alternatively a high capacitance (10 μ F) will avoid this issue altogether. Since the user will probably wish to have local decoupling at the load anyway, the most cost effective method is to use no capacitance at all directly across the device. PCB trace/via resistance and inductance prevent the local load decoupling from causing the oscillation during the transient start up phase.

Note: if the TS432 series is located right at the load, so the load decoupling capacitor is directly across it, then this capacitor will have to be ≤ 1 nF or ≥ 10 μ F.

Applications Examples

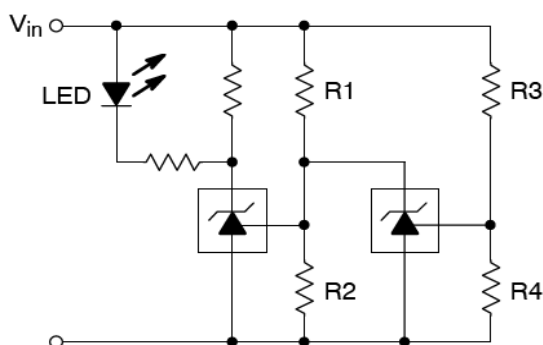

L.E.D. indicator is 'ON' when V_{in} is between the upper and lower limits,

$$\text{Lower limit} = \left(1 + \frac{R1}{R2} \right) V_{ref}$$

$$\text{Upper limit} = \left(1 + \frac{R3}{R4} \right) V_{ref}$$

Figure 4: Voltage Monitor

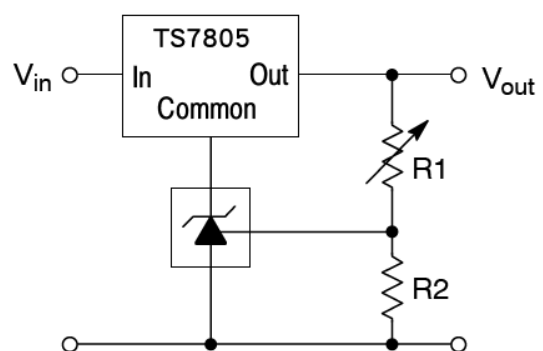

$$V_{out} = \left(1 + \frac{R1}{R2} \right) V_{ref}$$

$$V_{out(min)} = V_{ref} + 5.0 V$$

Figure 5: Output Control for Three Terminal Fixed Regulator

Applications Examples (Continue)

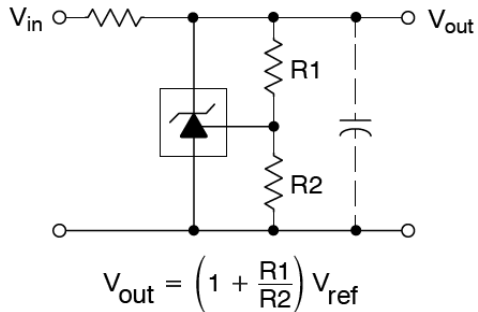

Figure 6: Shunt Regulator

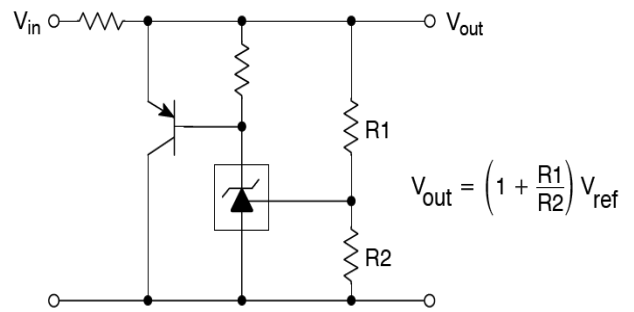

Figure 7: High Current Shunt Regulator

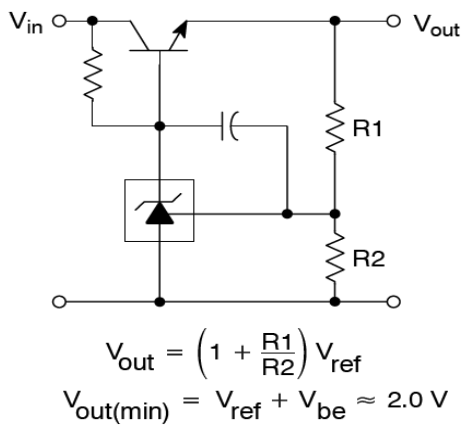

Figure 8: Series Pass Regulator

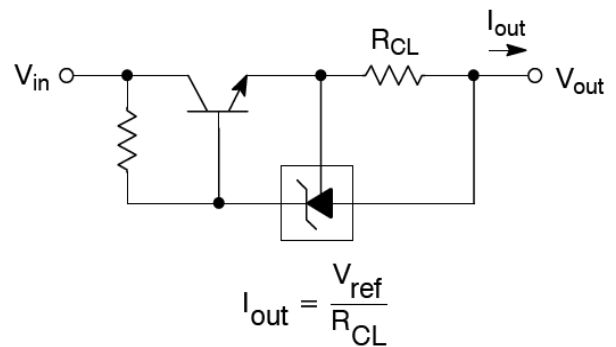

Figure 9: Constant Current Source

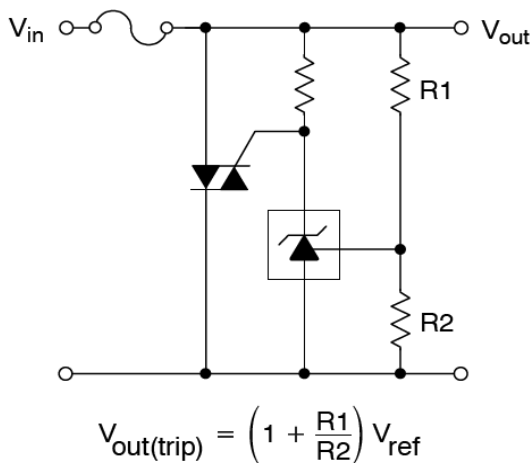

Figure 10: TRIAC Crowbar

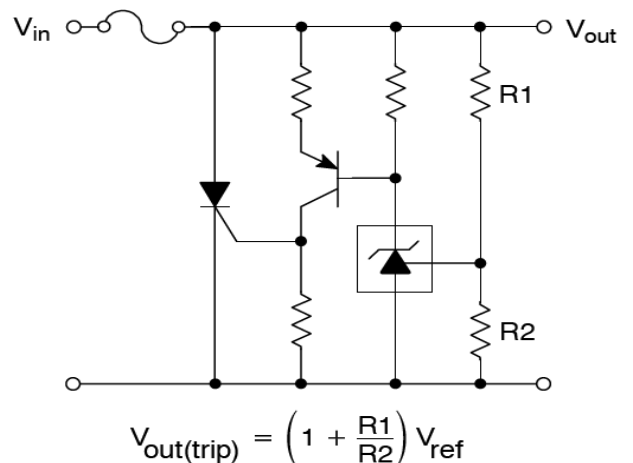

Figure 11: SCR Crowbar

Applications Examples (Continue)

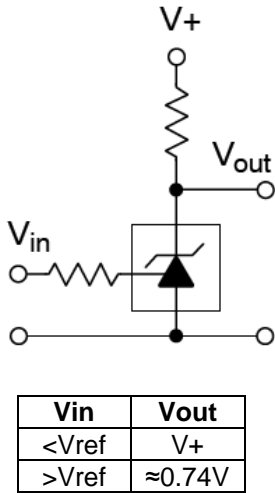

Figure 12: Single-Supply Comparator with Temperature-Compensated Threshold

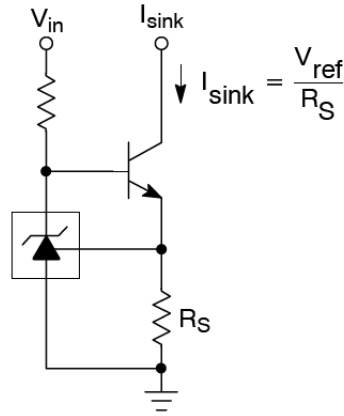

Figure 13: Constant Current Sink

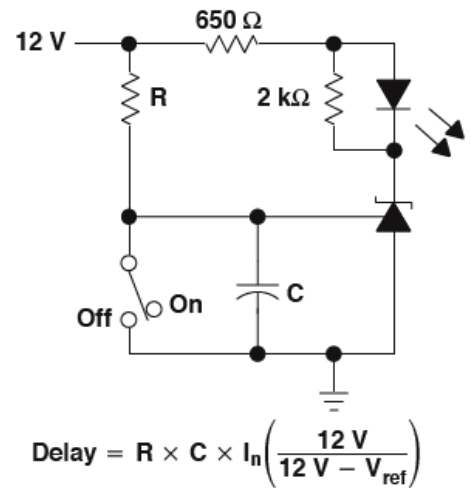
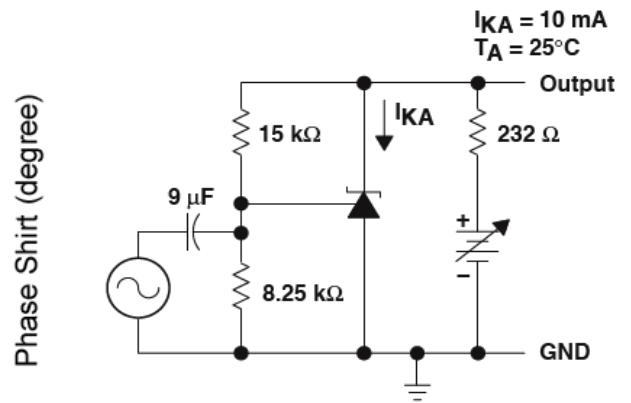
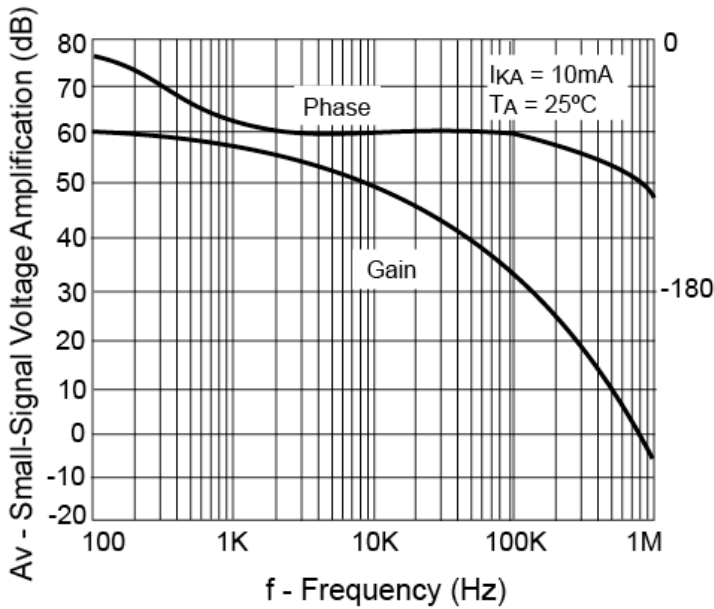

Figure 14: Delay Timer

Typical Performance Characteristics



Test Circuit for Voltage Amplification

Figure 15: Small-Signal Voltage Gain and Phase Shift vs. Frequency

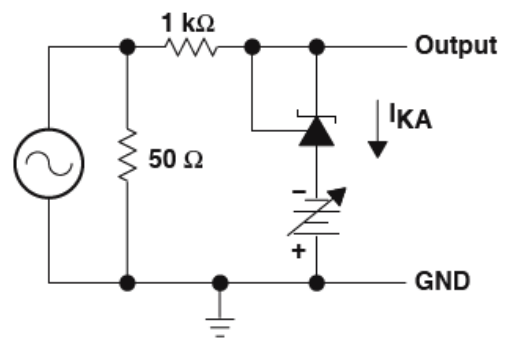
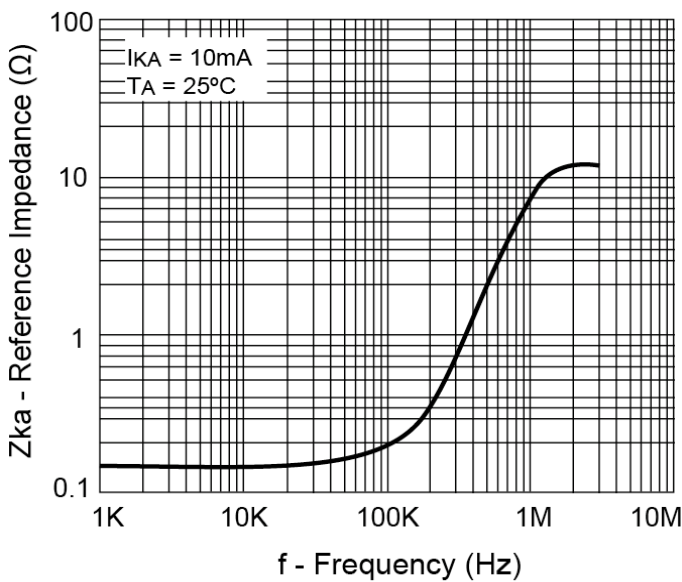

Test Circuit for Reference Impedance

Figure 16: Reference Impedance vs. Frequency

Typical Performance Characteristics

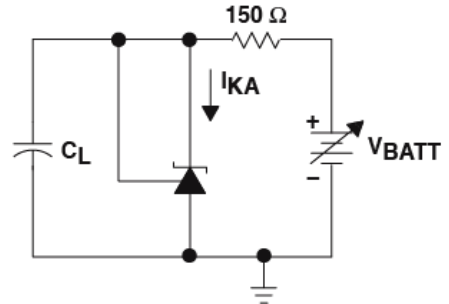
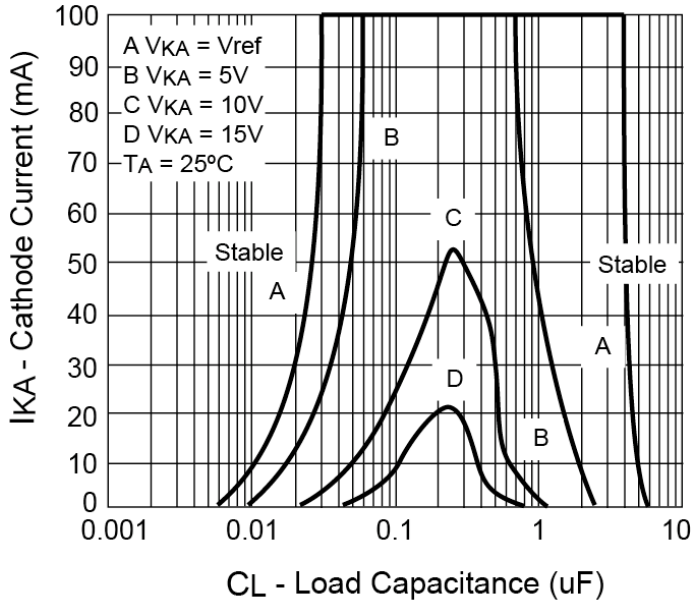

Test Circuit for Curve A

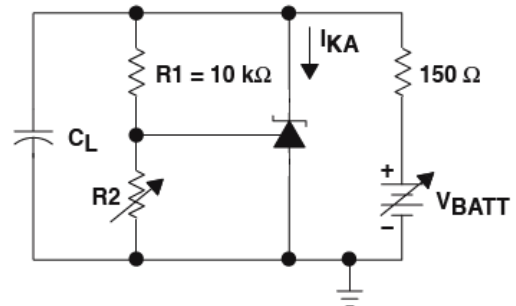

Test Circuit for Curve B, C and D

The areas under the curves represent conditions that may cause the device to oscillate. For curves B, C, and D, R_2 and V_+ were adjusted to establish the initial V_{KA} and I_{KA} conditions with $C_L=0$. V_{BATT} and C_L then were adjusted to determine the ranges of stability.

Figure 17: Stability Boundary Condition

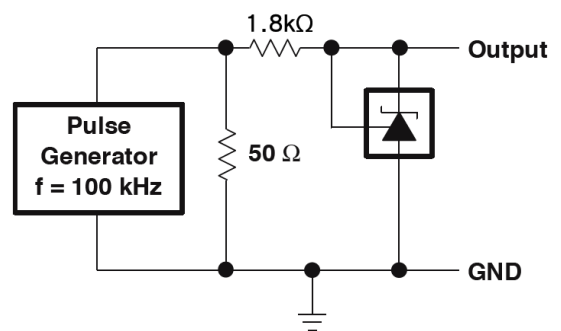
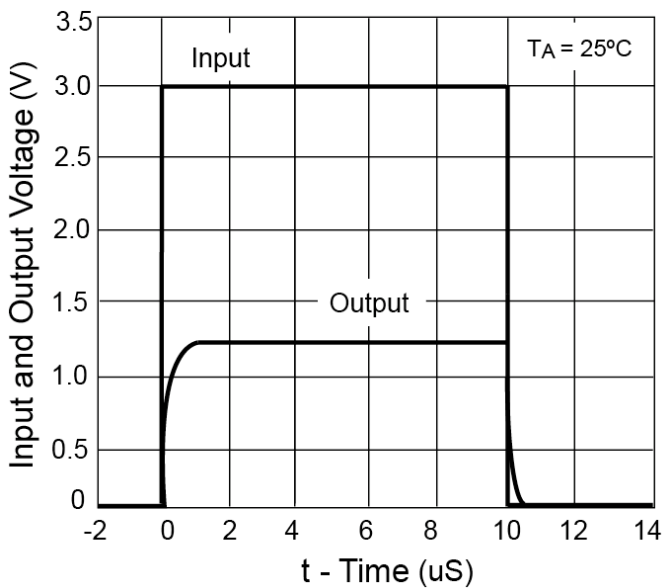

Test Circuit for Pulse Response, $I_k=1mA$

Figure 18: Pulse Response

Electrical Characteristics

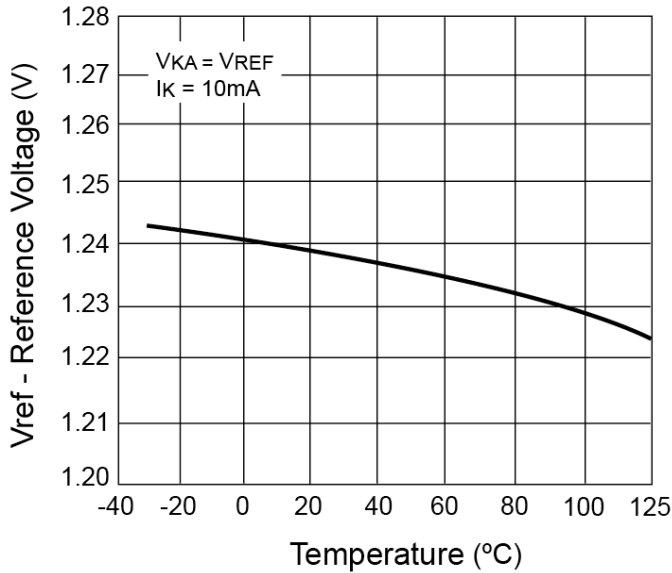

Figure 19: Reference Voltage vs. Temperature

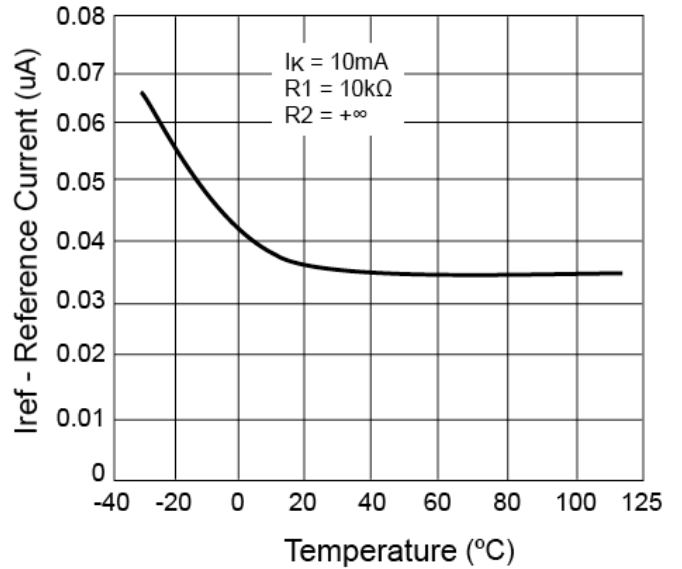

Figure 20: Reference Current vs. Temperature

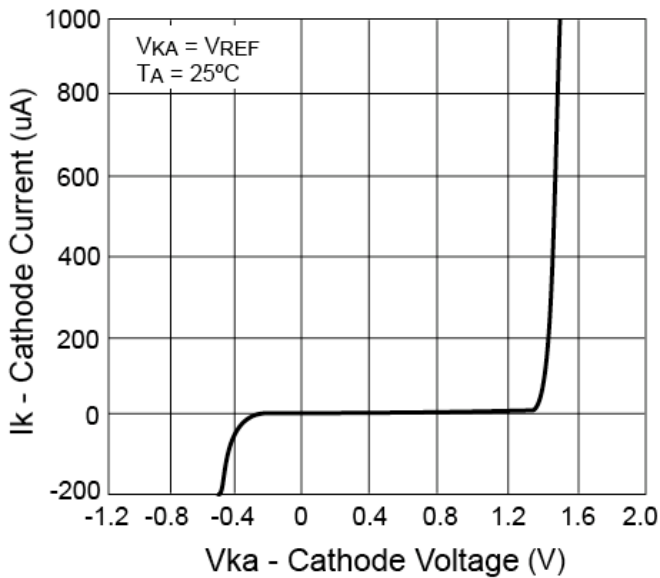
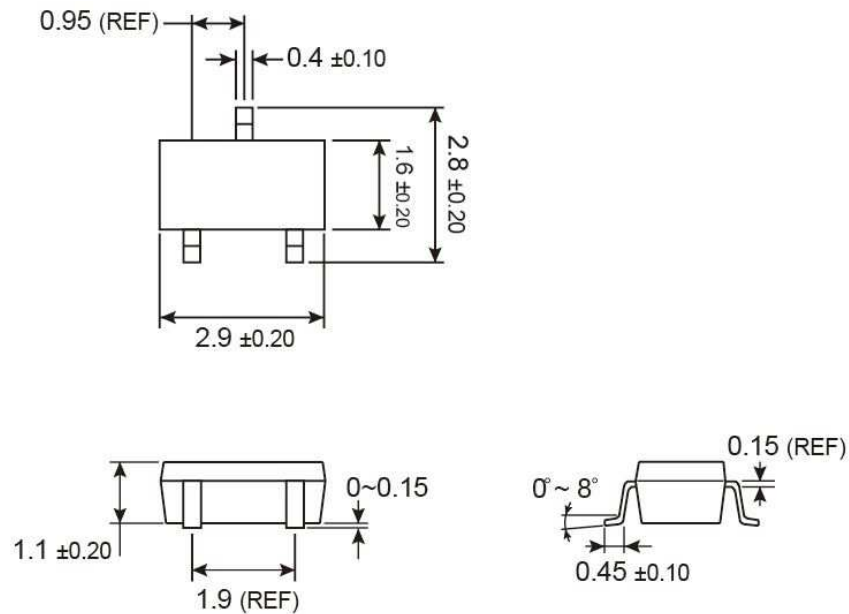

Figure 21: Cathode Current vs. Cathode Voltage

SOT-23 Mechanical Drawing



Unit: Millimeters

Marking Diagram

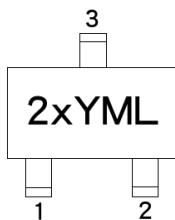

- 2** = Device Code
- X** = Tolerance Code
(**A** = $\pm 1\%$, **B** = $\pm 0.5\%$)
- Y** = Year Code
- M** = Month Code for Halogen Free Product
 - O** =Jan
 - P** =Feb
 - Q** =Mar
 - R** =Apr
 - S** =May
 - T** =Jun
 - U** =Jul
 - V** =Aug
 - W** =Sep
 - X** =Oct
 - Y** =Nov
 - Z** =Dec
- L** = Lot Code

TO-92 Mechanical Drawing

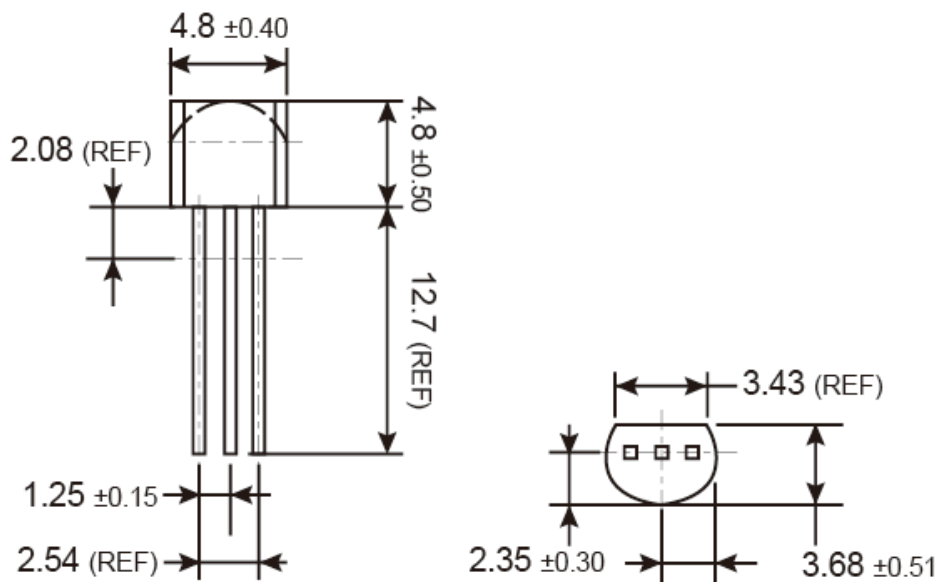

Unit: Millimeters

Marking Diagram

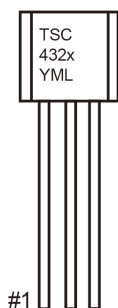

- X** = Tolerance Code
(**A** = ±1%, **B** = ±0.5%)
- Y** = Year Code
- M** = Month Code for Halogen Free Product
 - O** =Jan **P** =Feb **Q** =Mar **R** =Apr
 - S** =May **T** =Jun **U** =Jul **V** =Aug
 - W** =Sep **X** =Oct **Y** =Nov **Z** =Dec
- L** = Lot Code

TO-92 Ammo Pack Mechanical Drawing

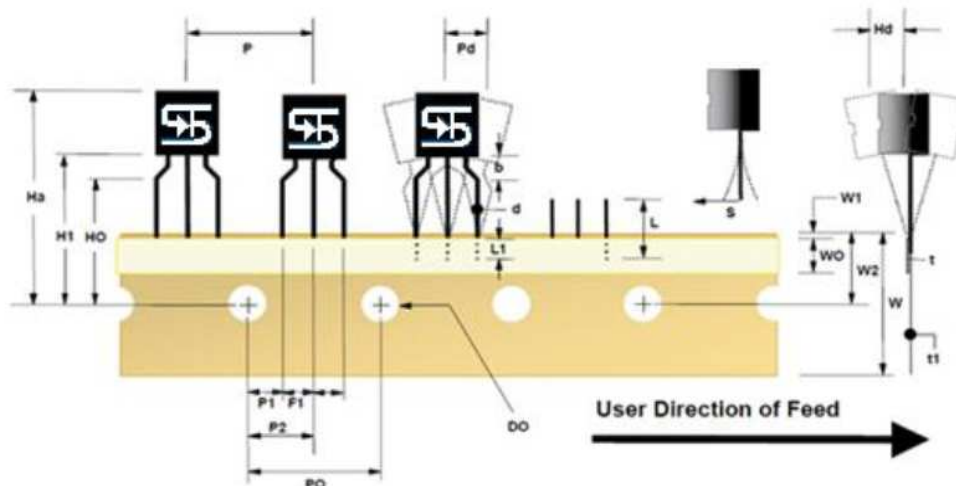

Tape Dimension

ITEM DESCRIPTION	SYMBOL	DIMENSION(mm)
Base of Package to Lead Bend	b	2.4892 (typ.)
Component Height	Ha	23.5712 (+/- 0.635)
Lead Clinch Height	HO	16.002 (+/- 0.508)
Component Base Height	H1	18.9992 (+/- 0.508)
Component Alignment (side / side)	Pd	1.016 (max)
Component Alignment (front / back)	Hd	0.7874 (max)
Component Pitch	P	12.7 (+/- 0.508)
Feed Hole Pitch	PO	12.7 (+/- 0.2032)
Hole Center to Component Center	P1	3.81 (+0.2286, -0.254)
Hole Center to Component Center	P2	6.2738 (+/- 0.1778)
Lead Spread	F1/F2	2.6416 (+/- 0.254)
Lead Thickness	d	0.4572 (+0.0508, -0.0762)
Cut Lead Length	L	10.8966 (max)
Taped Lead Length	L1	5.3086 (+1.2954, -1.3208)
Taped Lead Thickness	t	0.8218 (+/- 0.1524)
Carrier Tape Thickness	t1	0.5334 (+/- 0.1524)
Carrier Tape Width	W	17.9832 (+0.508, -0.4826)
Hold – down Tape Width	WO	5.9944 (+/- 0.3048)
Hold – down Tape position	W1	0.889 (max)
Feed Hole Position	W2	9.144 (+/- 0.635)
Sprocket Hole Diameter	DO	3.9878 (+0.2032, -0.1778)
Lead Spring Out	S	0.1016 (max)

Notice

Specifications of the products displayed herein are subject to change without notice. TSC or anyone on its behalf, assumes no responsibility or liability for any errors or inaccuracies.

Information contained herein is intended to provide a product description only. No license, express or implied, to any intellectual property rights is granted by this document. Except as provided in TSC's terms and conditions of sale for such products, TSC assumes no liability whatsoever, and disclaims any express or implied warranty, relating to sale and/or use of TSC products including liability or warranties relating to fitness for a particular purpose, merchantability, or infringement of any patent, copyright, or other intellectual property right.

The products shown herein are not designed for use in medical, life-saving, or life-sustaining applications. Customers using or selling these products for use in such applications do so at their own risk and agree to fully indemnify TSC for any damages resulting from such improper use or sale.

Компания «Life Electronics» занимается поставками электронных компонентов импортного и отечественного производства от производителей и со складов крупных дистрибьюторов Европы, Америки и Азии.

С конца 2013 года компания активно расширяет линейку поставок компонентов по направлению коаксиальный кабель, кварцевые генераторы и конденсаторы (керамические, пленочные, электролитические), за счёт заключения дистрибьюторских договоров

Мы предлагаем:

- Конкурентоспособные цены и скидки постоянным клиентам.
- Специальные условия для постоянных клиентов.
- Подбор аналогов.
- Поставку компонентов в любых объемах, удовлетворяющих вашим потребностям.
- Приемлемые сроки поставки, возможна ускоренная поставка.
- Доставку товара в любую точку России и стран СНГ.
- Комплексную поставку.
- Работу по проектам и поставку образцов.
- Формирование склада под заказчика.
- Сертификаты соответствия на поставляемую продукцию (по желанию клиента).
- Тестирование поставляемой продукции.
- Поставку компонентов, требующих военную и космическую приемку.
- Входной контроль качества.
- Наличие сертификата ISO.

В составе нашей компании организован Конструкторский отдел, призванный помогать разработчикам, и инженерам.

Конструкторский отдел помогает осуществить:

- Регистрацию проекта у производителя компонентов.
- Техническую поддержку проекта.
- Защиту от снятия компонента с производства.
- Оценку стоимости проекта по компонентам.
- Изготовление тестовой платы монтаж и пусконаладочные работы.



Тел: +7 (812) 336 43 04 (многоканальный)

Email: org@lifeelectronics.ru