

# DIO2524

## 2-Vrms Audio Driver with Integrated 4-ch, 11MHz, 6<sup>th</sup>-Order SD Video Filter

### Features

- Line Output: able to drive 600Ω and 10kΩ
  - 2-Vrms With 3.3V Supply Voltage
  - No Pop/Clicks Noise at the line output when Power ON/OFF
  - No Need for Output DC-Blocking Capacitors
  - Accepting Differential Input
- Optimized Frequency Response between 20Hz–20kHz
- Video Filter: Four-ch 6<sup>th</sup>-order 11MHz SD filters
- 6dB Output Driver Gain and Drive Dual Video Load
- Transparent Input Clamping
- AC or DC Coupled Inputs
- AC or DC Coupled Outputs
- Operates from 3.135V to 5.5V Single Power Supply

### Applications

- DVD Players
- Video Amplifiers
- Set-Top Boxes
- Personal Video Recorders
- Communications Devices

### Ordering Information

Order Part Number	Top Marking		T <sub>A</sub>	Package	
DIO2524CT24	DIO2524	Green/RoHS	-40 to +85°C	TSSOP-24	Tape & Reel, 2500

### Descriptions

The DIO2524 is an integrated solution for Video driver and Audio driver, with two separated modules, the Audio Driver module and 4-ch 6<sup>th</sup>-order 11MHz, SD Video filter driver module.

The Audio Driver allow for the removal of output AC-coupling capacitors. It is designed to optimize the audio driver circuit performance while reducing the BOM cost by eliminating the peripheral discrete components for noise reduction. Featuring differential input mode, gain range of  $\pm 1V/V$  to  $\pm 10V/V$  can be achieved via external gain resistor setting.

The Video filter is a low voltage, triple video amplifier with integrated reconstruction filter and input clamps. It provides improved image quality compared with passive LC filters and discrete drivers solution, especially suited for standard definition video signals, such as television and set-top box applications. All channels can be directly driven by a DC-coupled or an AC-coupled signal. Internal diode-like clamps and bias circuitry may be used if AC-coupled inputs are required. The output in the video filter can also drive AC or DC coupled single (150Ω) or dual (75Ω) loads. The DC coupling capacitors can be removed.



# DIO2524

## Pin Assignments

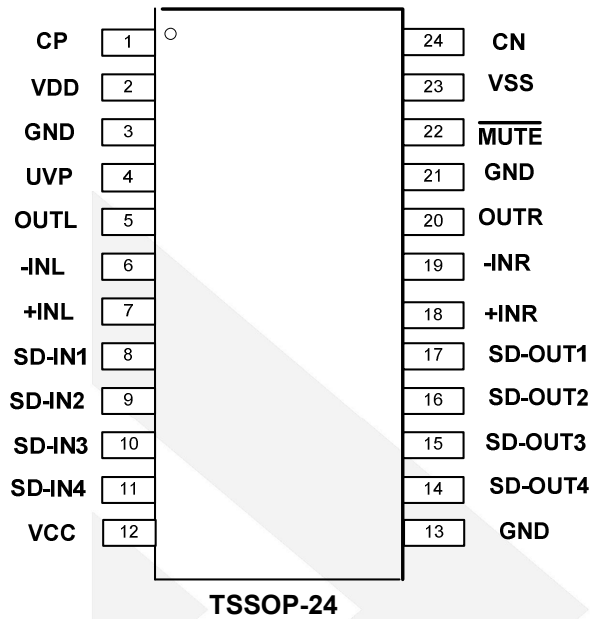

Figure 1 Pin Assignment

## Pin Description

Pin Name	Description
GND	GND
CP	Charge-pump flying capacitor positive terminal
VDD	Audio line driver positive supply
UVP	Under voltage protection input
OUTL	Left channel Output
-INL	Left channel Negative Input
+INL	Left channel Positive Input
SD-IN1	Channel SD Video Input1
SD-IN2	Channel SD Video Input2
SD-IN3	Channel SD Video Input3
SD-IN4	Channel SD Video Input4
VCC	Video filter driver power supply
SD-OUT4	Channel SD Video Output4
SD-OUT3	Channel SD Video Output3
SD-OUT2	Channel SD Video Output2
SD-OUT1	Channel SD Video Output1
+INR	Right channel Positive Input
-INR	Right channel Negative Input
OUTR	Right channel Output
Mute	Mute input, active-low
VSS	Supply voltage output
CN	Charge-pump flying capacitor negative terminal



# DIO2524

2-Vrms Audio Driver with Integrated 4-ch 6<sup>th</sup>-Order SD Video Filter

## Block Diagram

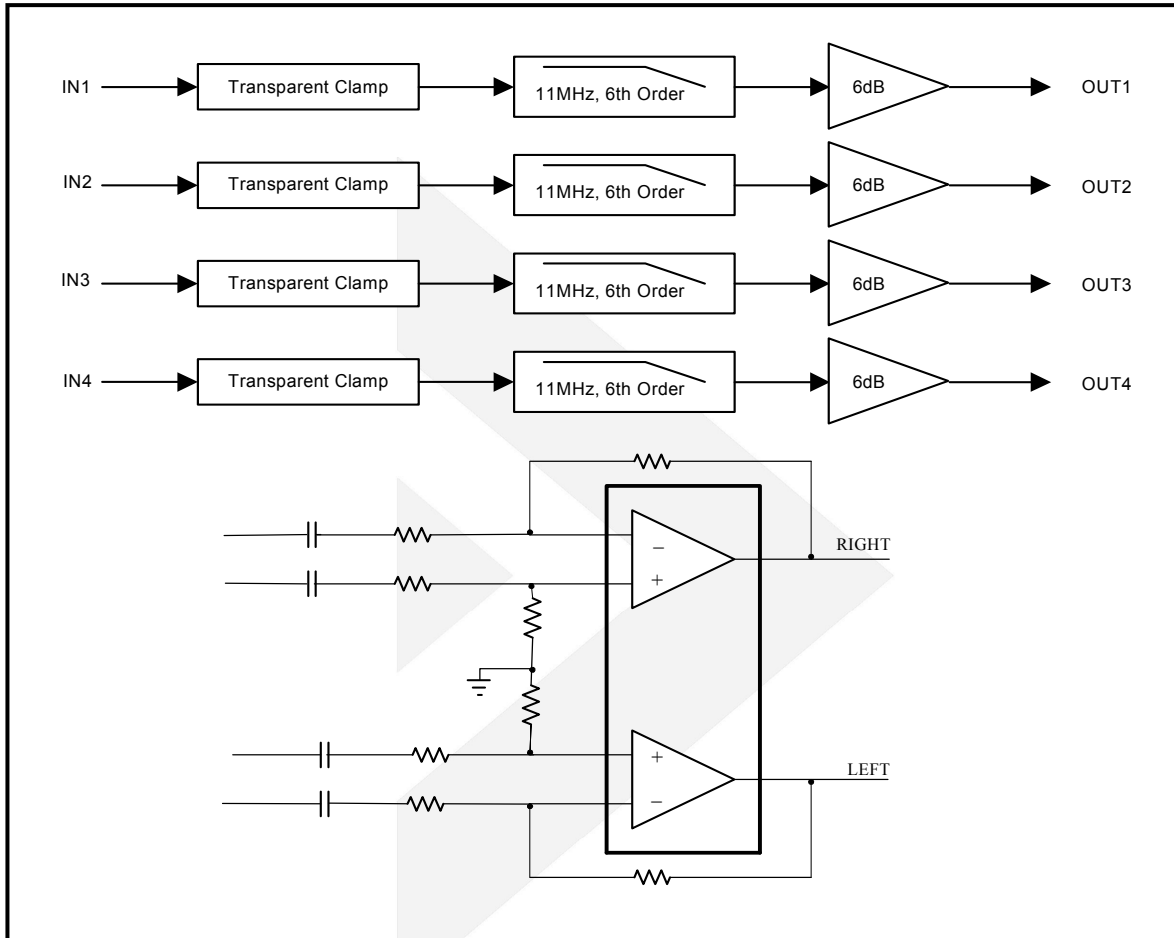

## Absolute Maximum Ratings

Stresses beyond those listed under "Absolute Maximum Rating" may cause permanent damage to the device. These are stress ratings only and functional operation of the device at these or any other condition beyond those indicated in the operational sections of the specifications is not implied. Exposure to absolute maximum rating conditions for extended periods may affect device reliability.

Parameter	Rating	Unit
Supply Voltage/VCC	0 to 6.0	V
Supply Voltage/VDD	-0.3 to 4	V
Input Voltage/VIN	-0.3 to $V_{CC}+0.3$	V
Input Voltage(+/-INR, +/-INL)	$V_{SS}-0.3$ to $V_{DD}+0.3$	V
Minimum load impedance	600	$\Omega$
$\overline{Mute}$ to GND	-0.3 to $V_{DD}+0.3$	V
Storage Temperature Range	-65 to 150	$^{\circ}\text{C}$
Junction Temperature	150	$^{\circ}\text{C}$
Lead Temperature Range	260	$^{\circ}\text{C}$
HBM ESD JEDEC: JESD22-A114	5	kV



# DIO2524

2-Vrms Audio Driver with Integrated 4-ch 6<sup>th</sup>-Order SD Video Filter

## Recommended Operating Conditions

The Recommended Operating Conditions table defines the conditions for actual device operation to ensure optimal performance to the datasheet specifications. DIOO does not recommend exceeding them or designing to Absolute Maximum Ratings.

Symbol	Parameter	Min.	Typ.	Max.	Unit
VDD	Supply Voltage	3	3.3	3.6	V
VCC	Supply Voltage	3.135		5.25	V
V <sub>IH</sub>	Mute High level Input Voltage		60		% of V <sub>DD</sub>
V <sub>IL</sub>	Mute Low level Input Voltage		40		% of V <sub>DD</sub>
T <sub>A</sub>	Operating Temperature Range	-40		85	°C

**Notes:** The items below were divided into two parts, the Audio driver module and the Video filter module.

## Electrical Characteristics for the Audio Driver module

Typical value: T<sub>A</sub> = 25°C, V<sub>DD</sub>=3.3V, R<sub>L</sub>=10kΩ, C<sub>PUMP</sub>=C<sub>PVSS</sub>=1μF, R<sub>IN</sub>=15kΩ, R<sub>fb</sub>=30kΩ, unless otherwise specified.

Symbol	Parameter	Conditions	Min.	Typ.	Max.	Unit
V <sub>OS</sub>	Output Offset Voltage	V <sub>DD</sub> =3.3V, Input grounded, Unity gain		0.8		mV
PSRR	Power supply rejection ratio	V <sub>DD</sub> =3.3V		90		dB
V <sub>OH</sub>	High level output voltage	V <sub>DD</sub> =3.3V, R <sub>L</sub> =10kΩ	3.1			V
V <sub>OL</sub>	Low level output voltage	V <sub>DD</sub> =3.3V, R <sub>L</sub> =10kΩ			-3.05	V
I <sub>IH</sub>	Mute High level input current	V <sub>DD</sub> =3.3V, V <sub>I</sub> =V <sub>DD</sub>			1	μA
I <sub>IL</sub>	Mute Low level input current	V <sub>DD</sub> =3.3V, V <sub>I</sub> =0V			1	μA
I <sub>DD</sub>	Supply current	V <sub>DD</sub> =3.3V, V <sub>I</sub> =V <sub>DD</sub> , No load		16		mA
		Mute mode, V <sub>DD</sub> =3.3V		0.8		
V <sub>O</sub>	Output Voltage	THD+N=1%, V <sub>DD</sub> =3.3V, f=1kHz	2.0	2.3		V <sub>RMS</sub>
THD+N	Total harmonic distortion + noise	V <sub>O</sub> =2V <sub>RMS</sub> , f=1kHz		0.001		%
X <sub>TALK</sub>	Channel crosstalk	V <sub>O</sub> =2V <sub>RMS</sub>		-105		dB
SNR	Signal noise ratio	A-weighted	90	105		dB
DNR	Dynamic range	A-weighted		105		dB
C <sub>L</sub>	Maximum capacitive load			220		pF
V <sub>N</sub>	Noise output voltage	A-weighted		10		μV <sub>RMS</sub>
G <sub>BW</sub>	Unity gain bandwidth			7.2		MHz
A <sub>VO</sub>	Open loop voltage gain			165		dB
V <sub>UVP</sub>	External under-voltage detection			1.25	1.325	V
I <sub>Hys</sub>	External under-voltage detection hysteresis current			6		μA
f <sub>CP</sub>	Charge pump frequency			300		kHz



# DIO2524

2-Vrms Audio Driver with Integrated 4-ch 6<sup>th</sup>-Order SD Video Filter

## Electrical Characteristics for the Video Filter module

Typical value:  $T_A = 25^\circ\text{C}$ ,  $V_{CC}=5\text{V}$ ,  $R_{SOURCE}=37.5\Omega$ ,  $R_L=150\Omega$  loads; all inputs are AC couple with  $0.1\mu\text{F}$ ; all outputs are AC coupled with  $220\mu\text{F}$ ; unless otherwise specified.

Symbol	Parameter	Conditions	Min.	Typ.	Max.	Unit
<b>DC ELECTRICAL CHARACTERISTICS</b>						
$I_{CC}$	Supply Current			32		mA
$V_{IN}$	Video Input Voltage Range			1.4		$V_{PP}$
PSRR	Power Supply Rejection			-50		dB
<b>DYNAMIC PERFORMANCE</b>						
AV	Channel Gain			6.0		dB
$F_{0.1dB}$	-0.1dB Bandwidth			5.8		MHz
$f_{1dB}$	-1dB Bandwidth			8.8		MHz
$f_{3dB}$	-3dB Bandwidth			11.0		MHz
	Filter Response	$f=27\text{MHz}$		-44		dB
DG	Differential Gain			0.2		%
DP	Differential Phase			0.36		$^\circ$
THD	Output Distortion	$f=1\text{MHz}$		0.38		%
$X_{TALK}$	Crosstalk	$f=1\text{MHz}$		-74		dB
SNR	Signal to Noise Ratio			70		dB
	Group Delay	$f=400\text{kHz}, 6.5\text{MHz}$		20		ns
CLG_SD	Chroma Luma Gain	$f=3.58\text{MHz}$ ref to SD in at 400kHz		100		%
CLD_SD	Chroma Luma Delay	$f=3.58\text{MHz}$ ref to SD in at 400kHz		5.5		ns

Notes:  $SNR=20 \cdot \log(714\text{mV} / \text{rms noise})$ .

Specifications subject to change without notice.



# DIO2524

2-Vrms Audio Driver with Integrated 4-ch 6<sup>th</sup>-Order SD Video Filter

## Typical Performance Characteristics for the Audio Driver

At  $V_{DD}=3.3V$ ,  $R_L=10k\Omega$ ,  $C_{PUMP}=C_{PVSS}=1\mu F$ ,  $R_{IN}=15k\Omega$ ,  $R_{fb}=30k\Omega$ ,  $T_A = +25^\circ C$ , unless otherwise noted.

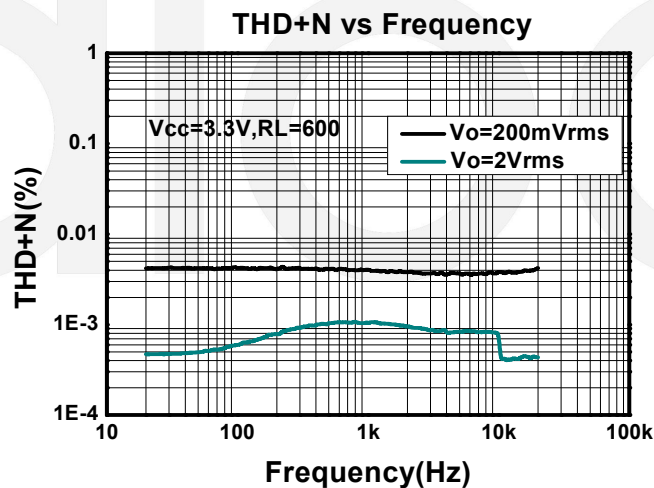
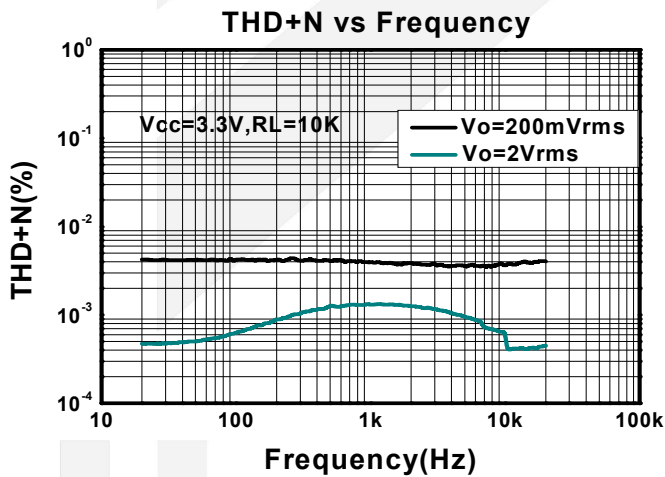
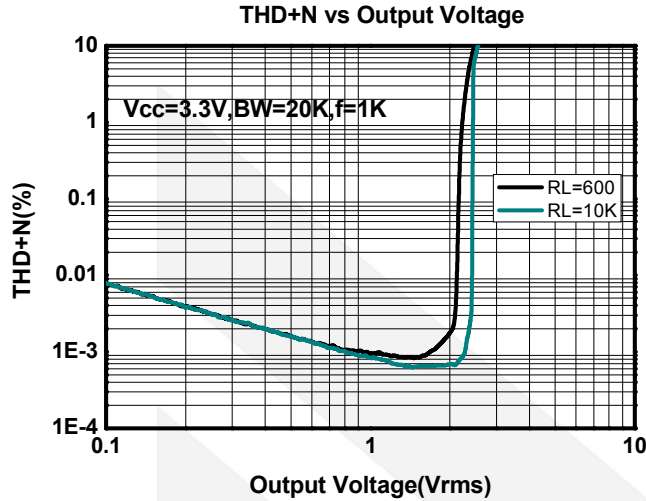



# DIO2524

2-Vrms Audio Driver with Integrated 4-ch 6<sup>th</sup>-Order SD Video Filter

## Typical Application

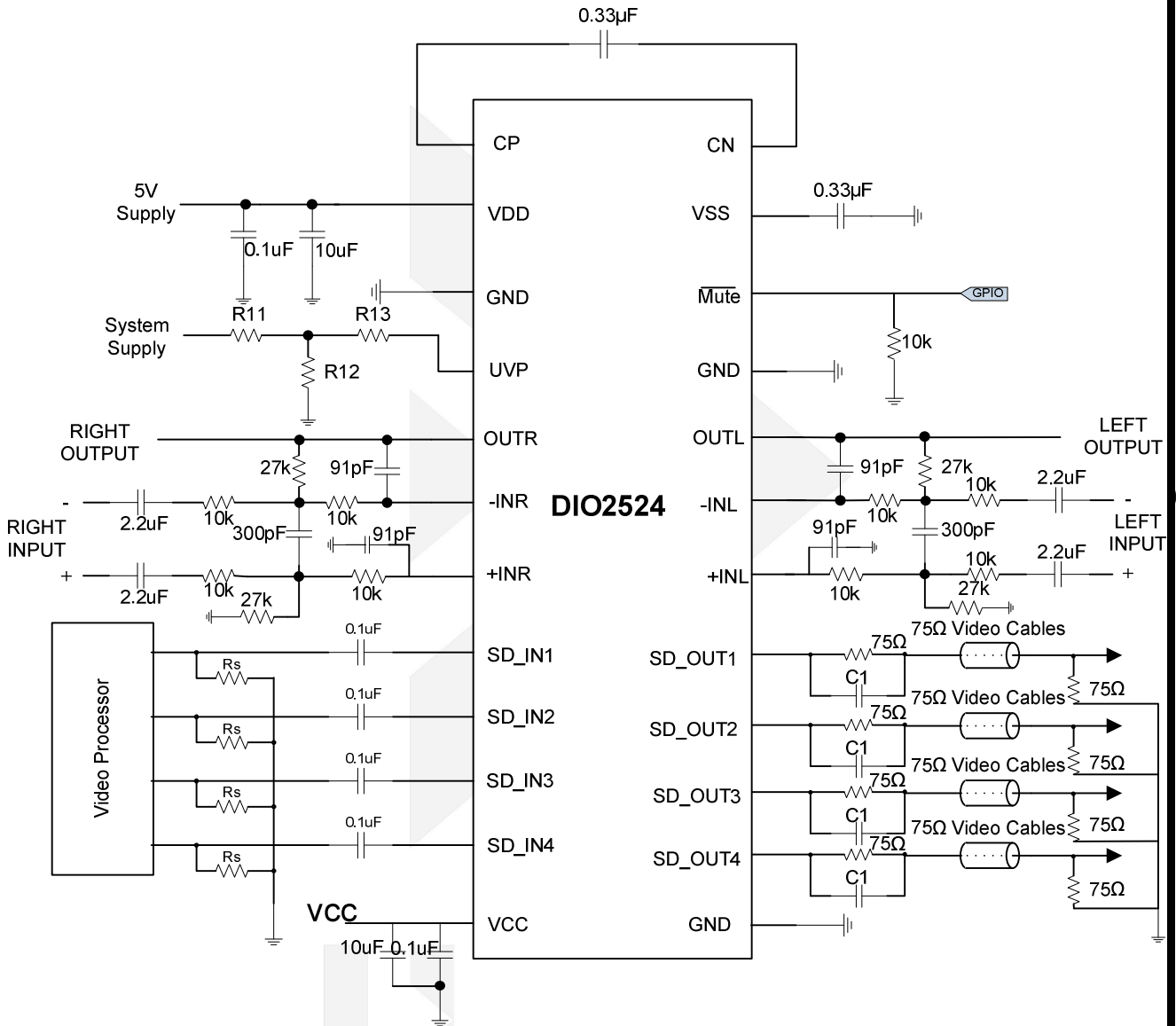

## Application Notes

### Important Note:

1. In some applications, if the power supply noise needs to be filtered, the ferrite bead is recommended in a value of 600Ω @100MHz, instead of RC network. RC network normally will lower the power supply resulting in the degraded the audio performance. If the resistor is not chosen properly, which can trigger the internal UVP detection circuit and mute the output. As depicted below.



2. In order to protect the device against the power surge, transient voltage suppressor (TVS) devices are recommended at the output pins OUTL/OUTR.

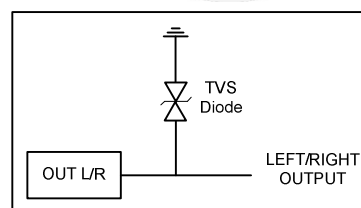

### Gain-Setting Resistors Ranges and Input-Blocking Capacitors

The gain-setting resistors,  $R_{IN}$  and  $R_{FB}$ , must be chosen so that noise, stability, and input capacitor size of the Audio Driver are kept within acceptable limits. Voltage gain is defined as  $R_{FB}$  divided by  $R_{IN}$ .

Table 1 lists the recommended resistor value for different gain settings. Selecting values that are too low demands a large input ac-coupling capacitor  $C_{IN}$ . Selecting values that are too high increases the noise of the amplifier.

The gain-setting resistor must be placed close to the input pins to minimize capacitive loading on these input pins and to ensure maximum stability.

**Table 1 Input Capacitor with 2Hz cutoff and Resistor Values Recommended**

Input Res., $R_{IN}$	Feedback Res., $R_{fb}$	Inverting Gain
22 k $\Omega$	22 k $\Omega$	-1 V/V
15 k $\Omega$	30 k $\Omega$	-2 V/V
10 k $\Omega$	100 k $\Omega$	-10 V/V

$$f_{CIN} = \frac{1}{2\pi R_{IN} C_{IN}}, \text{ or}$$

$$C_{IN} = \frac{1}{2\pi R_{IN} f_{CIN}}$$

**Equation 1 Cutoff decision Cutoff**

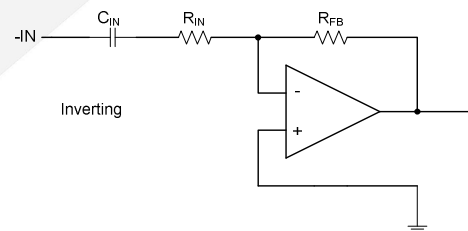

**Figure 2 Inverting Gain Configuration**

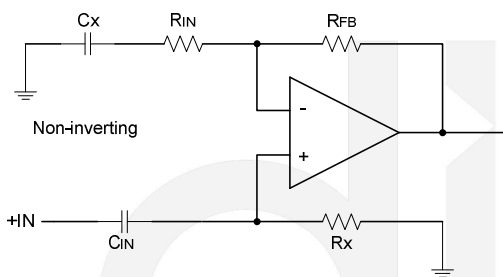

**Figure 3 Non-Inverting Gain Configuration**

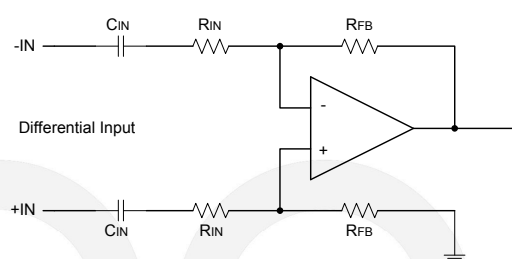

**Figure 4 Differential Gain Configuration**

### INPUT-BLOCKING CAPACITORS

DC input-blocking capacitors are required to be added in series with the audio signal into the input pins of the Audio Driver. These capacitors block the dc portion of the audio source and allow the Audio Driver inputs to be properly biased to provide maximum performance.



### 2nd Order Filter Typical Application

Several audio DACs used today require an external low-pass filter to remove out-of-band noise. This is possible with the Audio Driver, as it can be used like a standard OPAMP. Several filter topologies can be implemented, both single-ended and differential. In Figure 5, a multi-feedback (MFB) with differential input and single-ended input is shown.

An ac-coupling capacitor to remove dc content from the source is shown; it serves to block any dc content from the source and lowers the dc-gain to 1, helping reducing the output dc-offset to minimum.

The resistor values should have a low value for obtaining low noise, but should also have a high enough value to get a small size ac-coupling capacitor.

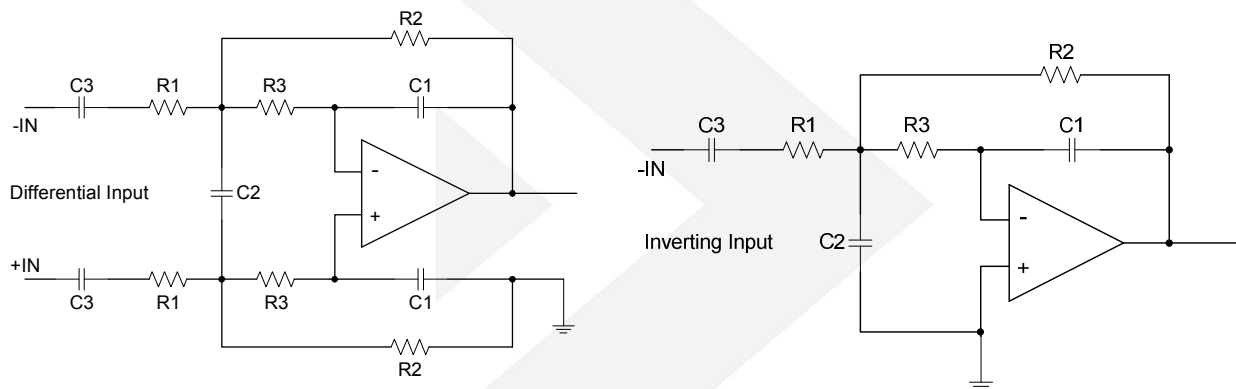

**Figure 5 Second-Order Active Low-Pass Filter**

### Charge Pump Flying Capacitor and VSS Capacitor

The charge pump flying capacitor serves to transfer charge during the generation of the negative supply voltage. The VSS capacitor must be at least equal to the charge pump capacitor in order to allow maximum charge transfer. Low-ESR capacitors are an ideal selection, and a value of 1 $\mu$ F is typical. Capacitor values that are smaller than 1 $\mu$ F can be used, but the maximum output voltage may be reduced and the device may not operate to specifications.

### Decoupling Capacitors

The Audio Driver requires adequate power supply decoupling to ensure that the noise and total harmonic distortion (THD) are low. A good low equivalent-series-resistance (ESR) ceramic capacitor, typically 1 $\mu$ F, placed as close as possible to the device VDD lead works best. Placing this decoupling capacitor close to the Audio Driver is important for the performance of the amplifier. For filtering lower-frequency noise signals, a 10 $\mu$ F or greater capacitor placed near the audio power amplifier would also help, but it is not required in most applications because of the high PSRR of this device.

### Pop-Free Power-Up

Pop-free power up is ensured by keeping the  $\overline{\text{Mute}}$  (shutdown pin) low during power-supply ramp up and ramp down. The  $\overline{\text{Mute}}$  pin should be kept low until the input ac-coupling capacitors are fully charged before asserting the  $\overline{\text{Mute}}$  pin high to achieve pop-less power up. Figure 6 illustrates the preferred sequence.

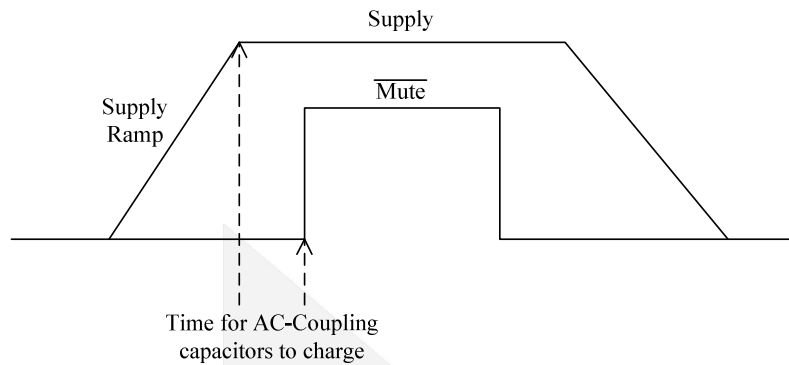

**Figure 6 Power-Up Sequences**

### External Under-voltage Detection

External under-voltage detection can be used to mute/shut down the DIO2524 before an input device can generate a pop. Although the shutdown voltage is 1.25V typically, customers need to consider the accuracy of system passive components such as resistors and associated temperature variation. In order to guarantee the power-on of the device, usually greater than 1.325V at UVP pin is recommended to cover the possible uncertainty. Users often select a resistor divider to obtain the power-on and shutdown threshold for the specific application. The typical thresholds can be calculated as follows, respectively for VSUP\_MO at 5V and 12V. Usually for best power down noise performance, 12V supply is recommended for UVP circuitry as below. Typically this 12V is the power supply which generates the 5V supply for DIO2524 VDD pins.

Case 1: VSUP\_MO= 12V (**Recommended**)

$$V_{UVP} = (1.25V - 6\mu A * R_{13}) * (R_{11} + R_{12}) / R_{12};$$

$$V_{hysteresis} = 5\mu A * R_{13} * (R_{11} + R_{12}) / R_{12};$$

With the condition  $R_{13} \gg R_{11} // R_{12}$ .

For example, if  $R_{11} = 11k$ ,  $R_{12} = 1.4k$  and  $R_{13} = 47k$ ,

Then  $V_{UVP} = 8.574V$ ;  $V_{hysteresis} = 2.081V$

Here,  $V_{UVP}$  is the shutdown threshold.

In this case, the voltage at UVP pin 4 is greater than 1.325V under worst case of VSUP\_MO ripples.

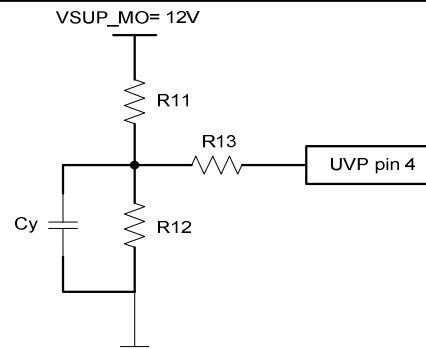

Case 2: VSUP\_MO= 5.0V

$$V_{UVP} = (1.205V - 6\mu A * R_{13}) * (R_{11} + R_{12}) / R_{12};$$

$$V_{hysteresis} = 5\mu A * R_{13} * (R_{11} + R_{12}) / R_{12};$$

With the condition  $R_{13} \gg R_{11} // R_{12}$ .

For example, if  $R_{11} = 5.6k$ ,  $R_{12} = 2.2k$  and  $R_{13} = 47k$ ,

Then  $V_{UVP} = 3.83V$ ;  $V_{hysteresis} = 0.247V$

Here,  $V_{UVP}$  is the shutdown threshold. In this case, the voltage at UVP pin 4 is greater than 1.325V under worst case of VSUP\_MO ripples.

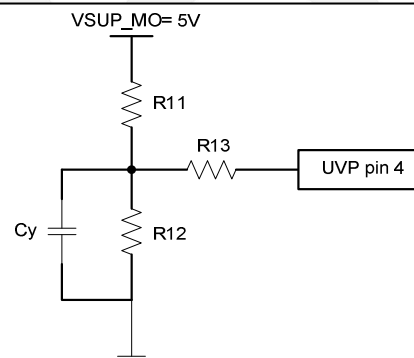



## DIO2524

To minimize the system power-up and power-down threshold variations, resistors with less than 1% variations are recommended. Although some resistor value options are offered above for customer's reference or starting points, customers should always verify those resistor options in their actual design. Customer can adjust their own design to achieving the best performance between pop noise and power-on threshold by adjusting the passive resistors R11, R12 and R13.

### Capacitive Load

The Audio Driver has the ability to drive a high capacitive load up to 220pF directly. Higher capacitive loads can be accepted by adding a series resistor of 47Ω or larger.

For further assistance, please contact DIOO worldwide sales office to seek technical support. You can find DIOO sales office information at [www.dioo.com](http://www.dioo.com).

2-Vrms Audio Driver with Integrated 4-ch 6<sup>th</sup>-Order SD Video Filter





# DIO2524

2-Vrms Audio Driver with Integrated 4-ch 6<sup>th</sup>-Order SD Video Filter

## Physical Dimensions: TSSOP24-0.65

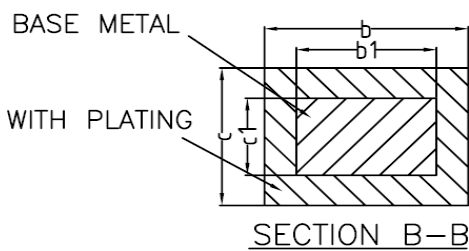
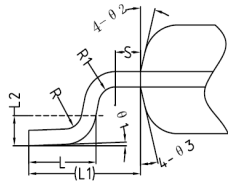
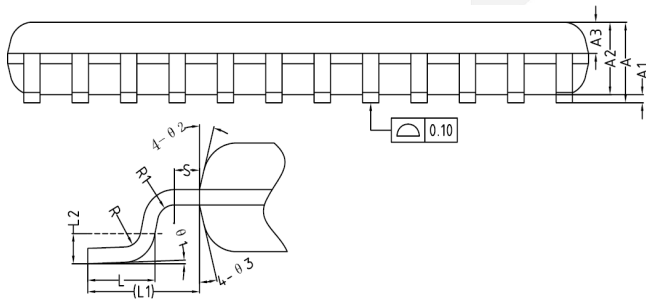
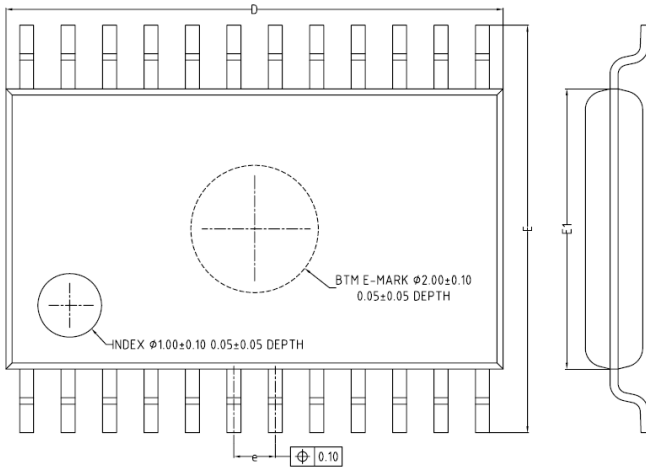

COMMON DIMENSIONS (UNITS OF MEASURE=MILLIMETER)			
Symbol	MIN	NOM	MAX
A	-	-	1.20
A1	0.05	-	0.15
A2	0.80	0.90	1.00
A3	0.34	0.39	0.44
b	0.20	-	0.29
b1	0.19	0.22	0.25
c	0.10	-	0.19
c1	0.10	0.13	0.15
D	7.70	7.80	7.90
E	6.20	6.40	6.60
E1	4.30	4.40	4.50
e	0.55	0.65	0.75
L	0.45	0.60	0.75
L1	1.00REF		
L2	0.25BSC		
R	0.09	-	-
R1	0.09	-	-
S	0.20	-	-
θ1	0°	-	8°
θ2	12°	14°	16°
θ3	12°	14°	16°



**DIO2524**

**2-Vrms Audio Driver with Integrated 4-ch 6<sup>th</sup>-Order SD Video Filter**

## **CONTACT US**

**D**ioo is a professional design and sales corporation for high-quality and performance analog semiconductors. The company focuses on industry markets, such as, cell phone, handheld products, laptop, and medical equipment and so on. Dioo's product families include analog signal processing and amplifying, LED drivers and charger IC. Go to <http://www.dioo.com> for a complete list of Dioo product families.

For additional product information, or full datasheet, please contact with our Sales Department or Representatives.

dioo

Компания «Life Electronics» занимается поставками электронных компонентов импортного и отечественного производства от производителей и со складов крупных дистрибьюторов Европы, Америки и Азии.

С конца 2013 года компания активно расширяет линейку поставок компонентов по направлению коаксиальный кабель, кварцевые генераторы и конденсаторы (керамические, пленочные, электролитические), за счёт заключения дистрибьюторских договоров

Мы предлагаем:

- Конкурентоспособные цены и скидки постоянным клиентам.
- Специальные условия для постоянных клиентов.
- Подбор аналогов.
- Поставку компонентов в любых объемах, удовлетворяющих вашим потребностям.
- Приемлемые сроки поставки, возможна ускоренная поставка.
- Доставку товара в любую точку России и стран СНГ.
- Комплексную поставку.
- Работу по проектам и поставку образцов.
- Формирование склада под заказчика.
- Сертификаты соответствия на поставляемую продукцию (по желанию клиента).
- Тестирование поставляемой продукции.
- Поставку компонентов, требующих военную и космическую приемку.
- Входной контроль качества.
- Наличие сертификата ISO.

В составе нашей компании организован Конструкторский отдел, призванный помогать разработчикам, и инженерам.

Конструкторский отдел помогает осуществить:

- Регистрацию проекта у производителя компонентов.
- Техническую поддержку проекта.
- Защиту от снятия компонента с производства.
- Оценку стоимости проекта по компонентам.
- Изготовление тестовой платы монтаж и пусконаладочные работы.



Тел: +7 (812) 336 43 04 (многоканальный)

Email: [org@lifeelectronics.ru](mailto:org@lifeelectronics.ru)