

High voltage high- and low-side driver for automotive applications

Datasheet - production data

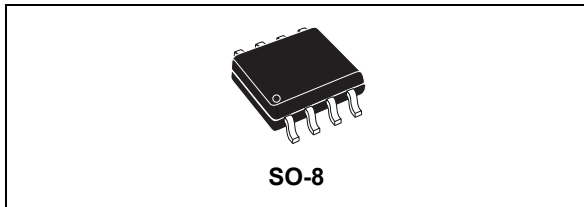

Features

- High voltage rail up to 550 V
- dV/dt immunity ± 50 V/nsec in full temperature range
- Driver current capability
 - 400 mA source
 - 650 mA sink
- Switching times 50/30 nsec rise/fall with 1 nF load
- CMOS/TTL Schmitt-trigger inputs with hysteresis and pull down
- Internal bootstrap diode

- Outputs in phase with inputs
- Interlocking function
- AECQ100 automotive qualified

Applications

- Drive inverters for HEV and EV
- HID ballasts, power supply units
- Motion driver for home appliances, factory automation, industrial drives

Description

The A6387 is a high voltage device, manufactured with the BCD™ “offline” technology. It is a single chip half-bridge gate driver for N-channel Power MOSFETs or IGBTs. The high-side (floating) section is designed to stand a voltage rail of up to 550 V. The logic inputs are CMOS/TTL compatible for easy interfacing of the microcontroller or DSP.

Figure 1. Block diagram

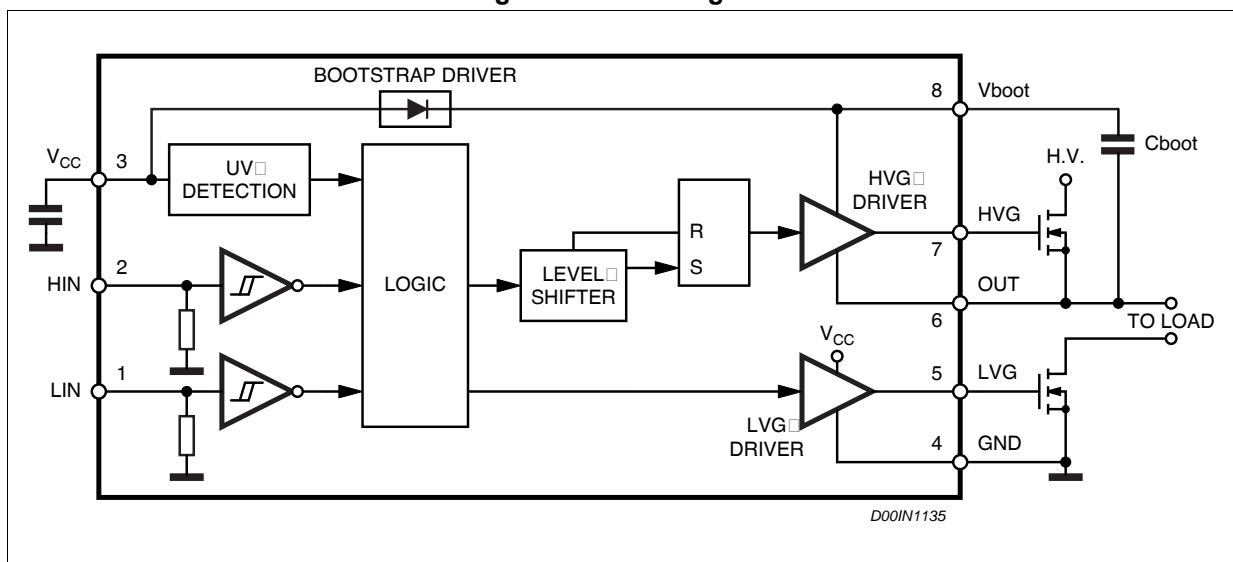

Contents

- 1 Electrical data 3**
 - 1.1 Absolute maximum ratings 3
 - 1.2 Thermal data 3
 - 1.3 Recommended operating conditions 3
- 2 Pin connection 4**
- 3 Electrical characteristics 5**
 - 3.1 AC operation 5
 - 3.2 DC operation 6
- 4 Input logic 7**
- 5 Bootstrap driver 8**
 - C_{BOOT} selection and charging 8
- 6 Typical characteristic 10**
- 7 Package information 11**
- 8 Ordering information 13**
- 9 Revision history 13**

1 Electrical data

1.1 Absolute maximum ratings

Table 1. Absolute maximum ratings

Symbol	Parameter	Min.	Max.	Unit
V_{CC}	Supply voltage	- 0.3	18	V
V_{out}	Output voltage	$V_{boot} - 18$	$V_{boot} + 0.3$	V
V_{boot}	Bootstrap voltage	- 0.3	568	V
V_{hvg}	High-side gate output voltage	$V_{out} - 0.3$	$V_{boot} + 0.3$	V
V_{lvg}	Low-side gate output voltage	- 0.3	$V_{CC} + 0.3$	V
V_i	Logic input voltage	- 0.3	$V_{CC} + 0.3$	V
dV_{out}/dt	Allowed output slew rate		50	V/ns
P_{tot}	Total power dissipation ($T_A = 85\text{ °C}$)		750	mW
T_j	Junction temperature		150	°C
T_{stg}	Storage temperature	-50	150	°C
ESD	Human Body Model	2		kV

1.2 Thermal data

Table 2. Thermal data

Symbol	Parameter	Value	Unit
$R_{th(JA)}$	Thermal resistance junction to ambient	150	°C/W

1.3 Recommended operating conditions

Table 3. Recommended operating conditions

Symbol	Pin	Parameter	Test condition	Min.	Max.	Unit
V_{CC}	3	Supply voltage		6.3	17	V
$V_{BO}^{(1)}$	8 - 6	Floating supply voltage			17	V
V_{out}	7	Output voltage		-6 ⁽²⁾	530	V
f_{sw}		Switching frequency	HVG, LVG load $C_L = 1\text{ nF}$		400	kHz
T_j		Junction temperature		-40	125	°C

1. $V_{BO} = V_{boot} - V_{out}$.

2. LVG off. $V_{CC} = 12\text{ V}$.

2 Pin connection

Figure 2. Pin connection (top view)

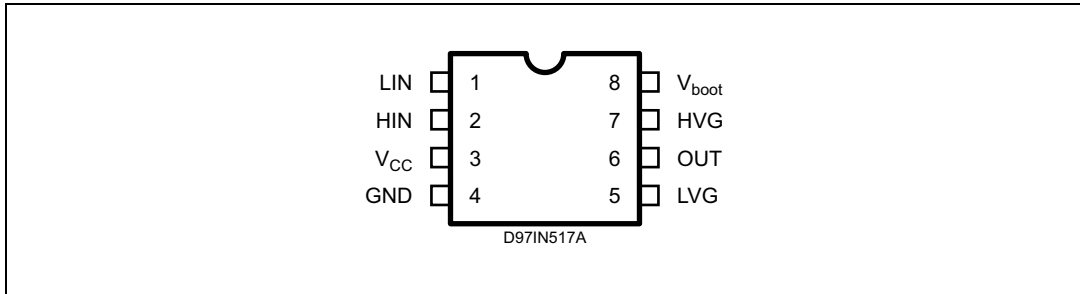

Table 4. Pin description

No.	Pin	Type	Function
1	LIN	I	Low-side driver logic input
2	HIN	I	High-side driver logic input
3	V _{CC}	P	Low voltage power supply
4	GND	P	Ground
5	LVG ⁽¹⁾	O	Low-side driver output
6	OUT	P	High-side driver floating reference
7	HVG ⁽¹⁾	O	High-side driver output
8	V _{boot}	P	Bootstrap supply voltage

1. The circuit provides less than 1 V on the LVG and HVG pins (at I_{sink} = 10 mA). This allows the omitting of the “bleeder” resistor connected between the gate and the source of the external MOSFET normally used to hold the pin low.

3 Electrical characteristics

3.1 AC operation

$V_{CC} = 15\text{ V}$; $T_J = -40\text{ }^\circ\text{C} \div 125\text{ }^\circ\text{C}$, unless otherwise specified.

Table 5. AC operation electrical characteristics

Symbol	Pin	Parameter	Test condition	Min.	Typ.	Max.	Unit
t_{on}	1 vs. 5 2 vs. 7	High/low-side driver turn-on propagation delay	$V_{out} = 0\text{ V}$ $V_{boot} = V_{CC}$ $C_L = 1\text{ nF}$	40	120	240	ns
t_{off}	1 vs. 5 2 vs. 7	High/low-side driver turn-off propagation delay		40	110	210	ns
t_r	5, 7	Rise time	$C_L = 1\text{ nF}$		50	100	ns
t_f	5, 7	Fall time			30	80	ns

Figure 3. Timing of input/output signals; turn-on/off propagation delays

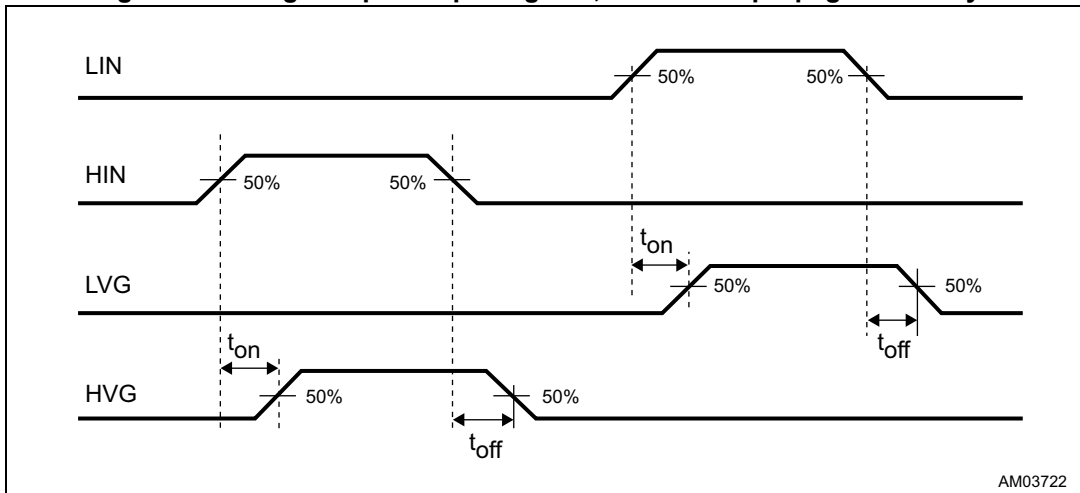

3.2 DC operation

V_{CC} = 15 V; T_J = -40 °C ÷ 125 °C, unless otherwise specified

Table 6. DC operation electrical characteristics

Symbol	Pin	Parameter	Test condition	Min.	Typ.	Max.	Unit
Low supply voltage section							
V _{CC_thON}	3	V _{CC} UV turn-on threshold		5.5	6	6.3	V
V _{CC_thOFF}		V _{CC} UV turn-off threshold		5	5.5	6	V
V _{CC_hys}		V _{CC} UV hysteresis		0.3	0.5	0.7	V
I _{qccu}		Undervoltage quiescent supply current	V _{CC} ≤ 5 V		150	220	μA
I _{qcc}		Quiescent current			250	320	μA
R _{DSon}		Bootstrap driver on resistance ⁽¹⁾	LVG ON		125		Ω
Bootstrapped supply voltage section ⁽²⁾							
I _{QBO}	8	V _{BO} quiescent current	HVG ON			100	μA
I _{LK}		High voltage leakage current	V _{hvg} = V _{out} = V _{boot} = 550 V			10	μA
High/low-side driver							
I _{so}	5, 7	High/low-side source short-circuit current	V _{IN} = V _{ih} (t _p < 10 μs)	300	400		mA
I _{si}		High/low-side sink short-circuit current	V _{IN} = V _{il} (t _p < 10 μs)	450	650		mA
Logic inputs							
V _{il}	1,2	Low level logic threshold voltage				1.4	V
V _{ih}		High level logic threshold voltage		3.2			V
I _{ih}		High level logic input current	V _{IN} = 15 V	8	20	40	μA
I _{il}		Low level logic input current	V _{IN} = 0 V			1	μA

1. R_{DS(on)} is tested in the following way:

$$R_{DS(on)} = \frac{(V_{CC} - V_{BOOT1}) - (V_{CC} - V_{BOOT2})}{I_1(V_{CC}, V_{BOOT1}) - I_2(V_{CC}, V_{BOOT2})}$$

where I₁ is pin 8 current when V_{BOOT} = V_{BOOT1}, I₂ when V_{BOOT} = V_{BOOT2}.

2. V_{BO} = V_{boot} - V_{out}.

4 Input logic

The A6387 input logic is V_{CC} (17 V) compatible. An interlocking feature is offered (see [Table 7](#)) to avoid undesired simultaneous turn-on of both power switches driven.

Table 7. Input logic

Input		Output	
HIN	LIN	HVG	LVG
0	0	0	0
0	1	0	1
1	0	1	0
1	1	0	0

Figure 4. Timing of input/output signals; interlocking waveforms definition

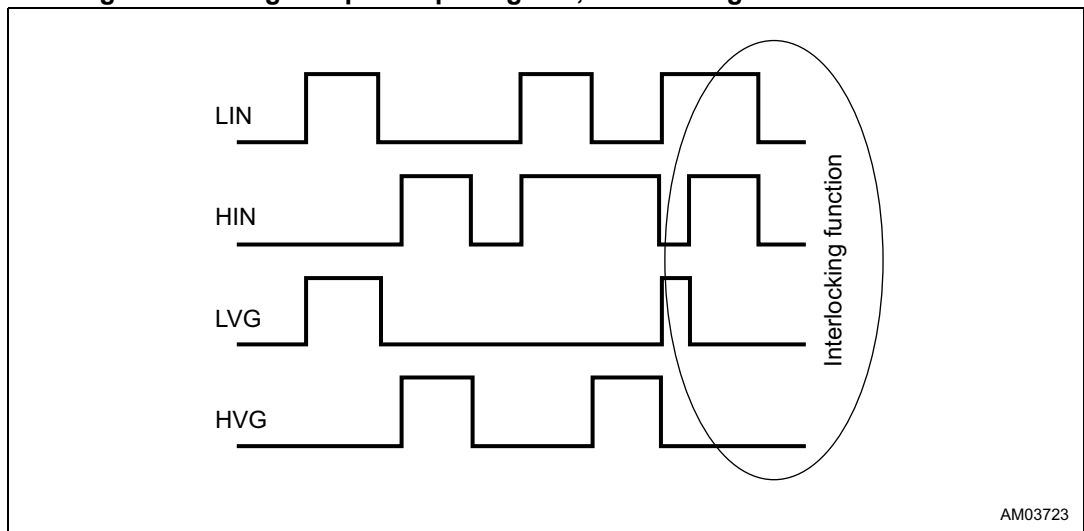

5 Bootstrap driver

A bootstrap circuitry is needed to supply the high voltage section. This function is normally accomplished by a high voltage fast recovery diode (*Figure 5 a*). In the A6387 device a patented integrated structure replaces the external diode. It is realized by a high voltage DMOS, driven synchronously with the low-side driver (LVG), with a diode in series, as shown in *Figure 5 b*. An internal charge pump (*Figure 5 b*) provides the DMOS driving voltage.

C_{BOOT} selection and charging

To choose the proper C_{BOOT} value the external MOS can be seen as an equivalent capacitor. This capacitor C_{EXT} is related to the MOS total gate charge:

Equation 1

$$C_{EXT} = \frac{Q_{gate}}{V_{gate}}$$

The ratio between the capacitors C_{EXT} and C_{BOOT} is proportional to the cyclical voltage loss. It must be:

$$C_{BOOT} \gg C_{EXT}$$

For example: if Q_{gate} is 30 nC and V_{gate} is 10 V, C_{EXT} is 3 nF. With $C_{BOOT} = 100$ nF the drop would be 300 mV.

If HVG must be supplied for a long period, the C_{BOOT} selection must take into account also the leakage and quiescent losses.

For example: HVG steady-state consumption is lower than 100 μ A, therefore, if HVG T_{ON} is 5 ms, C_{BOOT} must supply 0.5 μ C to C_{EXT} . This charge on a 1 μ F capacitor means a voltage drop of 0.5 V.

The internal bootstrap driver offers a big advantage: the external fast recovery diode can be avoided (it usually has very high leakage current).

This structure can work only if V_{OUT} is close to GND (or lower) and, in the meantime, the LVG is on. The charging time (T_{charge}) of the C_{BOOT} is the time in which both conditions are fulfilled and it must be long enough to charge the capacitor.

The bootstrap driver introduces a voltage drop due to the DMOS R_{DSon} (typical value: 125 Ω). This drop can be neglected at low switching frequency, but it should be taken into account when operating at high switching frequency.

Equation 2 is useful to compute the drop on the bootstrap DMOS:

Equation 2

$$V_{drop} = I_{charge} R_{dson} \rightarrow V_{drop} = \frac{Q_{gate}}{T_{charge}} R_{dson}$$

where Q_{gate} is the gate charge of the external power MOS, R_{DSon} is the ON-resistance of the bootstrap DMOS, and T_{charge} is the charging time of the bootstrap capacitor.

For example: using a power MOS with a total gate charge of 30 nC, the drop on the bootstrap DMOS is about 1 V, if the T_{charge} is 5 μs . In fact:

Equation 3

$$V_{drop} = \frac{30nC}{5\mu s} \cdot 125\Omega \sim 0.8V$$

V_{drop} should be taken into account when the voltage drop on C_{BOOT} is calculated: if this drop is too high, or the circuit topology doesn't allow a sufficient charging time, an external diode can be used.

Figure 5. Bootstrap driver

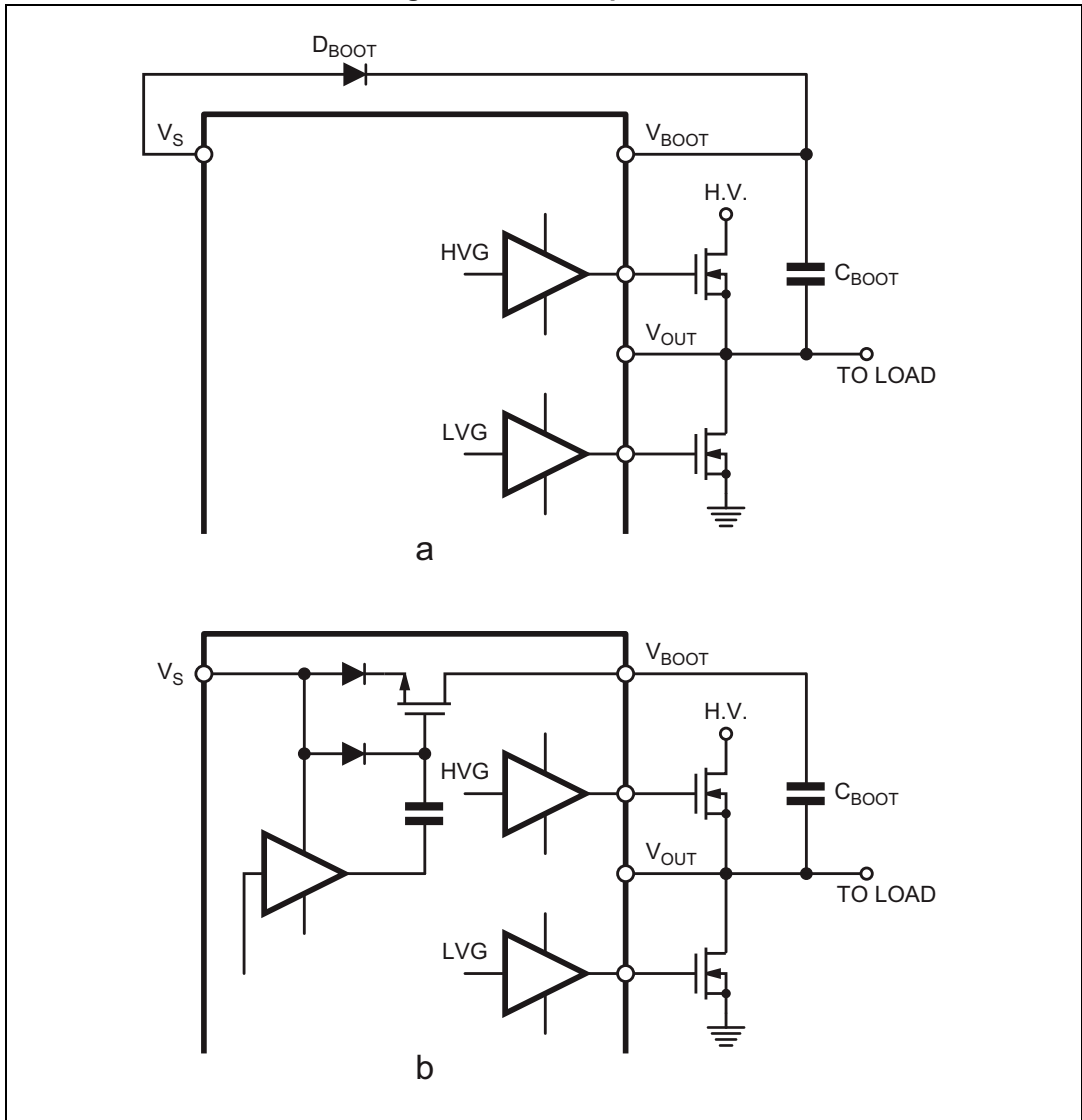

6 Typical characteristic

Figure 6. Typical rise and fall times vs. load capacitance

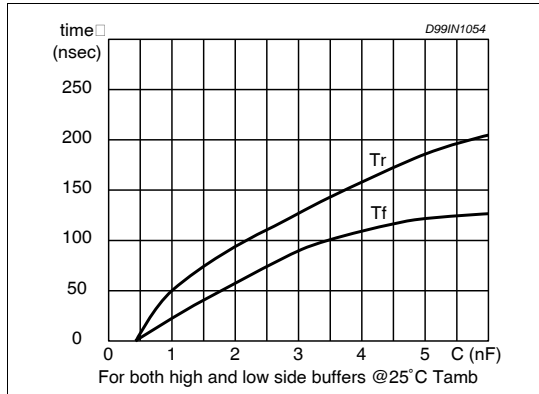

Figure 7. Quiescent current vs. supply voltage

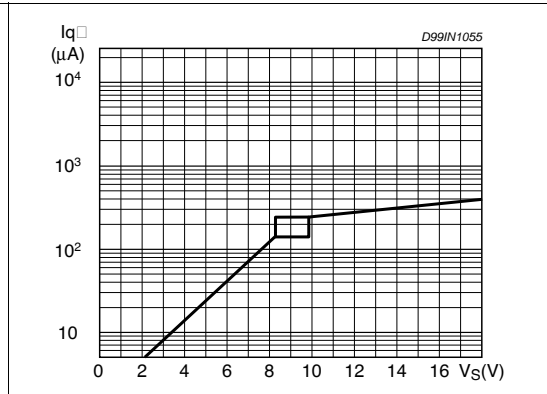

Figure 8. Turn-on time vs. temperature

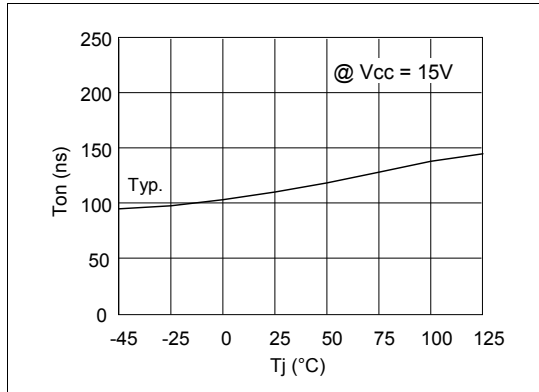

Figure 9. Turn-off time vs. temperature

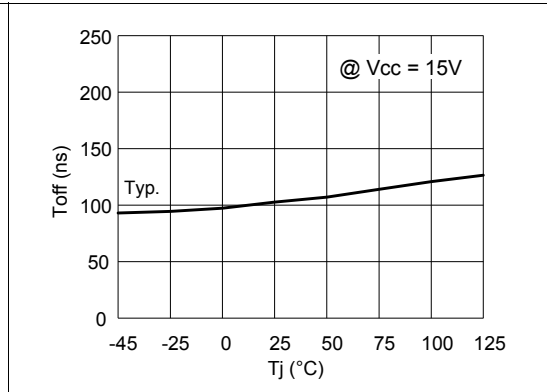

Figure 10. Output source current vs. temperature

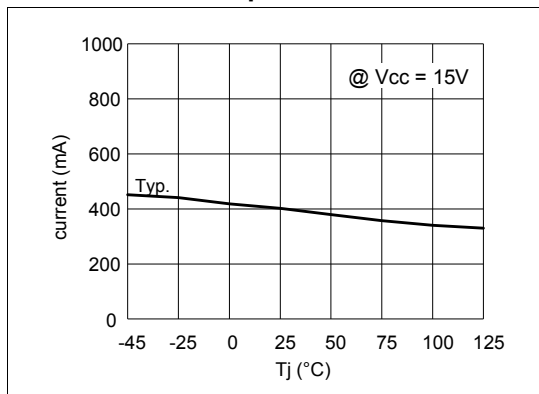
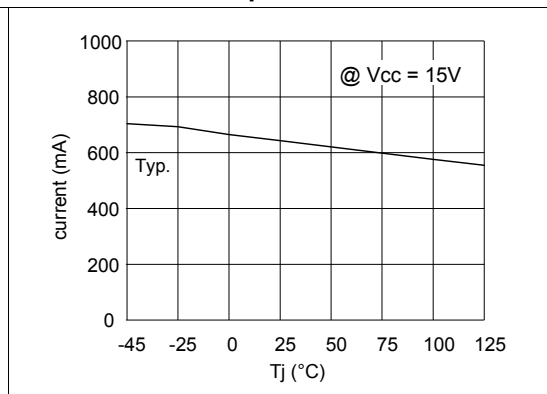

Figure 11. Output sink current vs. temperature



7 Package information

In order to meet environmental requirements, ST offers these devices in different grades of ECOPACK® packages, depending on their level of environmental compliance. ECOPACK specifications, grade definitions and product status are available at: www.st.com. ECOPACK is an ST trademark.

Figure 12. SO-8 package outline

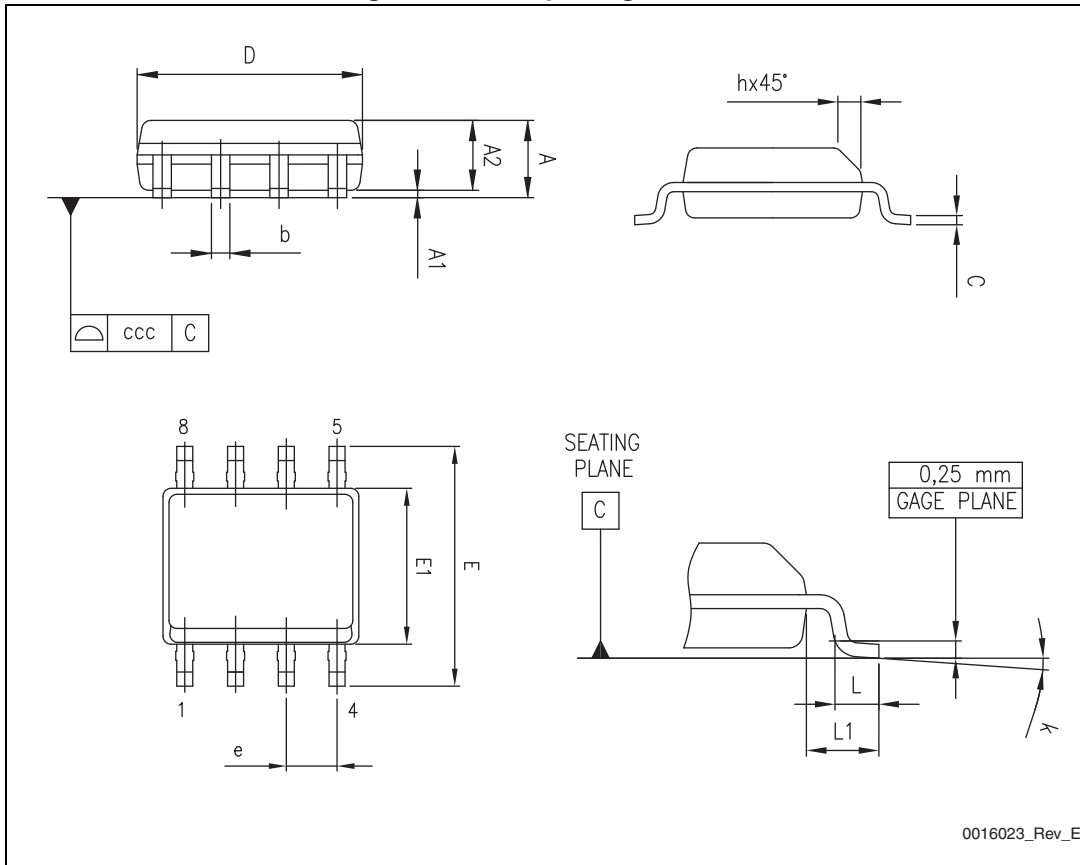

Table 8. SO-8 package mechanical data

Symbol	Dimensions (mm)		
	Min.	Typ.	Max.
A			1.75
A1	0.10		0.25
A2	1.25		
b	0.28		0.48
c	0.17		0.23
D	4.80	4.90	5.00
E	5.80	6.00	6.20
E1	3.80	3.90	4.00
e		1.27	
h	0.25		0.50
L	0.40		1.27
L1		1.04	
k	0°		8°
ccc			0.10

8 Ordering information

Table 9. Ordering information

Order code	Package	Packaging
A6387D	SO-8	Tube
A6387DTR	SO-8	Tape and reel

9 Revision history

Table 10. Document revision history

Date	Revision	Changes
05-Jul-2012	1	First release
10-Oct-2013	2	Updated: Section : Features on page 1 (added "AECQ100 compliant"). Section : Applications on page 1 added: – Drive inverters for HEV and EV, – HID ballasts, power supply units, – Motion driver for home appliances, factory automation, industrial drives. Table 1 on page 3 (removed note below Table 1). Minor corrections throughout document.
22-Oct-2013	3	Updated Section : Features on page 1 ("replaced AECQ100 compliant" by "AECQ100 automotive qualified").
14-Apr-2014	4	Updated Section 3.1: AC operation on page 5 (added Figure 3). Updated Section 4: Input logic on page 7 (added Figure 4).
04-Feb-2015	5	Updated Table 1 (added <i>Human Body Model</i> parameter). Updated minimum supply voltage in Table 3 and maximum V_{CC} UV turn-on threshold voltage in Table 6 . Corrected typo in $R_{DS(on)}$ testing equation in footnote of Table 6 . Updated Figure 5: Bootstrap driver .

IMPORTANT NOTICE – PLEASE READ CAREFULLY

STMicroelectronics NV and its subsidiaries ("ST") reserve the right to make changes, corrections, enhancements, modifications, and improvements to ST products and/or to this document at any time without notice. Purchasers should obtain the latest relevant information on ST products before placing orders. ST products are sold pursuant to ST's terms and conditions of sale in place at the time of order acknowledgement.

Purchasers are solely responsible for the choice, selection, and use of ST products and ST assumes no liability for application assistance or the design of Purchasers' products.

No license, express or implied, to any intellectual property right is granted by ST herein.

Resale of ST products with provisions different from the information set forth herein shall void any warranty granted by ST for such product.

ST and the ST logo are trademarks of ST. All other product or service names are the property of their respective owners.

Information in this document supersedes and replaces information previously supplied in any prior versions of this document.

© 2015 STMicroelectronics – All rights reserved

Компания «Life Electronics» занимается поставками электронных компонентов импортного и отечественного производства от производителей и со складов крупных дистрибьюторов Европы, Америки и Азии.

С конца 2013 года компания активно расширяет линейку поставок компонентов по направлению коаксиальный кабель, кварцевые генераторы и конденсаторы (керамические, пленочные, электролитические), за счёт заключения дистрибьюторских договоров

Мы предлагаем:

- Конкуренеспособные цены и скидки постоянным клиентам.
- Специальные условия для постоянных клиентов.
- Подбор аналогов.
- Поставку компонентов в любых объемах, удовлетворяющих вашим потребностям.
- Приемлемые сроки поставки, возможна ускоренная поставка.
- Доставку товара в любую точку России и стран СНГ.
- Комплексную поставку.
- Работу по проектам и поставку образцов.
- Формирование склада под заказчика.
- Сертификаты соответствия на поставляемую продукцию (по желанию клиента).
- Тестирование поставляемой продукции.
- Поставку компонентов, требующих военную и космическую приемку.
- Входной контроль качества.
- Наличие сертификата ISO.

В составе нашей компании организован Конструкторский отдел, призванный помогать разработчикам, и инженерам.

Конструкторский отдел помогает осуществить:

- Регистрацию проекта у производителя компонентов.
- Техническую поддержку проекта.
- Защиту от снятия компонента с производства.
- Оценку стоимости проекта по компонентам.
- Изготовление тестовой платы монтаж и пусконаладочные работы.



Тел: +7 (812) 336 43 04 (многоканальный)
Email: org@lifeelectronics.ru