

Ordering a market-ready enclosure® is made fast and affordable with our complete in-house capabilities. New Age provides machined openings to fit your PCB, pad printing for your graphics, custom enclosures, custom colors, final assembly, testing and fulfillment services to save you additional time and money. Ask your representative for a free quote today 805-595-1310.

Fast and Affordable Customization

**CNC Modifications
Pad Printing
Colored Resins
EMI/RF Shielding
Custom Enclosure
Assembly & Testing**

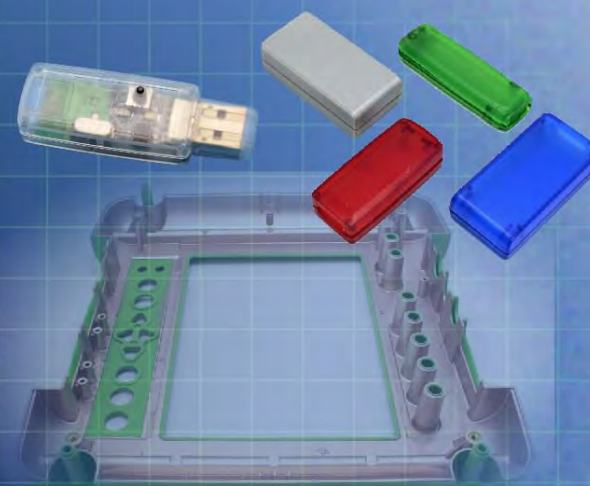

ISO quality
off-the-shelf
to market-ready®

NEW AGE ENCLOSURES

www.NewAgeEnclosures.com

4330 Santa Fe Road • San Luis Obispo, CA 93401 • T 805.595.1310 • F 805.595.1024

NOTES: UNLESS OTHERWISE SPECIFIED

- CORNERS DRAWN SHARP TO BE R.005 MAXIMUM.
- EXTERIOR SURFACE TEXTURE TO BE LIGHT EDM FINISH. EQUIVALENT TO MT-11010.
- INTERIOR SURFACE TEXTURE TO BE: NONE.
- ALL INSIDE RADII .010R. ALL OUTSIDE RADII .020R MAX, UNLESS OTHERWISE SPECIFIED.
- ALL EXTERNAL DIMENSIONS AFFECTED BY THE DRAFT APPLY AT THE LARGE END OF THE FEATURE, AND ALL INTERNAL FEATURES AFFECTED BY THE DRAFT APPLY AT THE SMALL END OF THE FEATURE UNLESS OTHERWISE SPECIFIED.
- 1 DEGREE DRAFT IN THE DIRECTION OF PULL IS PERMISSIBLE UNLESS OTHERWISE SPECIFIED.
- ASSEMBLY SCREWS FOR THE ENCLOSURE INCLUDED.
- MATERIAL / COLOR: ABS PLASTIC IS STANDARD IN BLACK OR WHITE. CUSTOM MATERIALS AND COLORS ARE AVAILABLE UPON REQUEST FOR QUOTE.
- PCB SIZES ARE RECOMMENDATIONS ONLY. FINAL SIZES AND VERIFICATION OF ITS FIT ARE THE SOLE RESPONSIBILITY OF EACH CUSTOMER.

| S302112(x) CONFIGURATIONS | | | | | |
|---------------------------|--------|----|----|-----|-----|
| | -Blank | -T | -K | -TK | -WP |
| 302112 COVER | 1 | | 1 | | |
| 302112T COVER | | 1 | | 1 | |
| 302112 BASE | 1 | 1 | | | |
| 302112 MACHINED BASE | | | 1 | 1 | |
| 302112 HATCH | 1 | 1 | 1 | 1 | |
| 302112 WALL CRADLE | | | 1 | 1 | 1 |
| #4 HiLo SCREW .500" | 4 | 4 | 4 | 4 | |

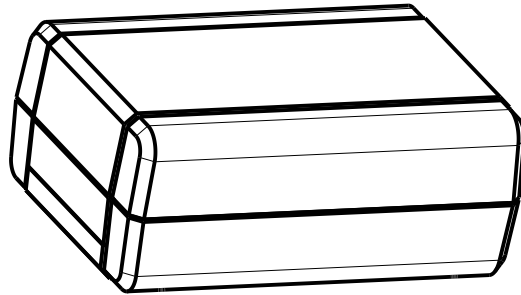

302112 STANDARD
SCALE 0.750

R E V I S I O N

| REV. | DRAWN BY | ECO No | DESCRIPTION | DATE | APPROVED |
|------|----------|--------|---|-----------|----------|
| A | M BOYER | | PRELIMINARY RELEASE | 21-Nov-09 | D.C. |
| H | M BOYER | | ADD RIBS AFTER REVIEW 7-12-10 | 13-Jul-10 | D.C. |
| 1.0 | M BOYER | | RELEASED BY CUSTOMER | 21-Jul-10 | D.C. |
| 2.0 | M BOYER | 3810 | ADJUST PCB INFO AND PCB POSTS | 28-Sep-10 | D.C. |
| 2.1 | M BOYER | 3810 | UNAPPROVED REV 2.0, UPDATE FORMAT | 30-Sep-10 | D.C. |
| 3.0 | R CRUZ | 7613 | ADD "TALL" CONFIGURATION | 18-Oct-13 | D.C. |
| 4.0 | M BOYER | 8613 | INCLUDE WALL CRADLE OPTION | 16-Dec-13 | D.C. |
| 5.0 | R CRUZ | 2214 | UPDATE CONFIGURATION TABLE | 19-May-14 | D.C. |
| 5.1 | R CRUZ | 5014 | REMOVE SCREW HOLE ON CRADLE, "TALL" CONFIGURATION | 26-Nov-14 | D.C. |
| 6.0 | M BOYER | 00615 | INCLUDE KEEP OUT ZONE AND ADD NOTCHES TO PCB | 23-Jan-15 | |

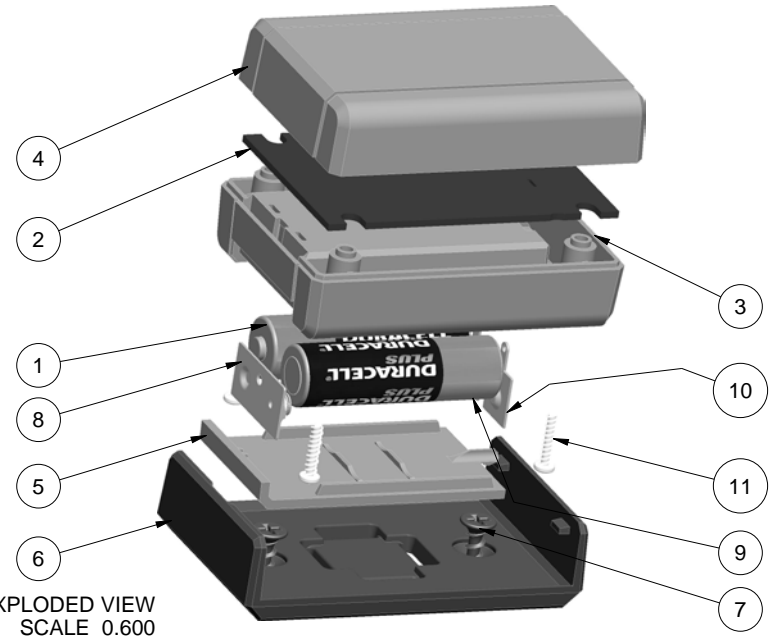

EXPLODED VIEW
SCALE 0.600

| ITEM | FILE NAME | DESCRIPTION | MATERIAL | COLOR | QTY. |
|------|----------------------|-------------------------------|-------------------|-----------------|------|
| 11 | SCREW_HILO-N04X500 | #4 HiLo x .500" SCREW | STEEL | ZINK PLATED | 4 |
| 10 | AA-SINGL-CONTACT-POS | ACC-AAPOS-5223 | SPRING STEEL | SOLD SEPERATELY | 1 |
| 9 | AA-SINGL-CONTACT-NEG | ACC-AANEG-5201 | SPRING STEEL | SOLD SEPERATELY | 1 |
| 8 | AA-DBL-CONTACT | ACC-AADBL-5212 | SPRING STEEL | SOLD SEPERATELY | 1 |
| 7 | SCREW-DRYWALLX750 | DRYWALL SCREW - REFERENCE | CUSTOMER SUPPLIED | DRYWALL SCREW | 2 |
| 6 | 302112_WALL-CRADLE | 302112 WALL CRADLE - STANDARD | ABS | BLACK or WHITE | 1 |
| 5 | 302112_HATCH | 302112 HATCH - STANDARD | ABS | BLACK or WHITE | 1 |
| 4 | 302112_COVER | 302112 COVER - STANDARD | ABS | BLACK or WHITE | 1 |
| 3 | 302112_BASE | 302112 BASE - STANDARD | ABS | BLACK or WHITE | 1 |
| 2 | 302112_PCB | 302112 PCB - REFERENCE | CUSTOMER SUPPLIED | .062" THICK | 1 |
| 1 | AA-BATTERY | AA BATTERY - REFERENCE | CUSTOMER SUPPLIED | "AA" SIZE | 2 |

BILL OF MATERIALS

THIRD ANGLE PROJECTION
DO NOT SCALE DRAWING

TOLERANCES: UNLESS OTHERWISE SPECIFIED
DIMENSIONS ARE IN U.S. INCHES.
X.XX = .015 X.XXXX = .001
X.XXX = .010 X.X" = 1°

NEW AGE ENCLOSURES
4330 Santa Fe Road San Luis Obispo, CA. 93401
ph. (805) 595-1310 fax (805) 595-1024

Customer's Part No: 302112

APPROVAL BY DATE

CHECK ENG.

SCALE AS NOTED

DRAWN BY M BOYER 21-Nov-09

www.newageenclosures.com

STANDARD - MINI AA
SXX-302112X-XXX

SIZE A DRAWING NAME 302112_R6_0 SHEET 1 OF 9 REV.DOC 6.0

NOTICE: THE INFORMATION AND DATA CONTAINED HEREIN IS CONSIDERED PROPRIETARY TO ALLTEC INTEGRATED MFG INC & SHALL REMAIN THE EXCLUSIVE PROPERTY OF ALLTEC INTEGRATED MFG INC. THE HOLDER WILL ASSUME CUSTODY AND CONTROL THAT THIS DOCUMENT WILL NOT BE COPIED, REPRODUCED, OR DISCLOSED WITHOUT THE EXPRESS WRITTEN CONSENT OF ALLTEC INTEGRATED MFG INC. THIS DOCUMENT DOES NOT CONSTITUTE A GRANT TO MANUFACTURE ANY ITEMS.
© 2014

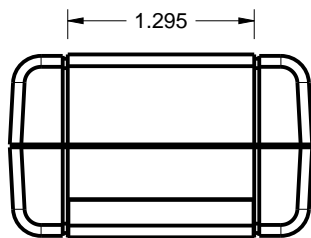
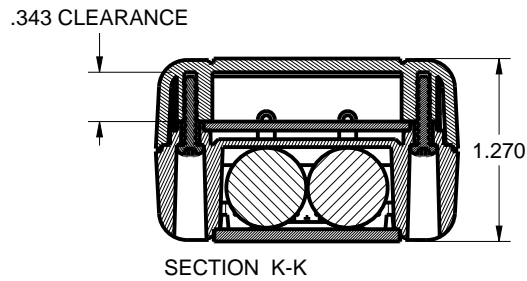
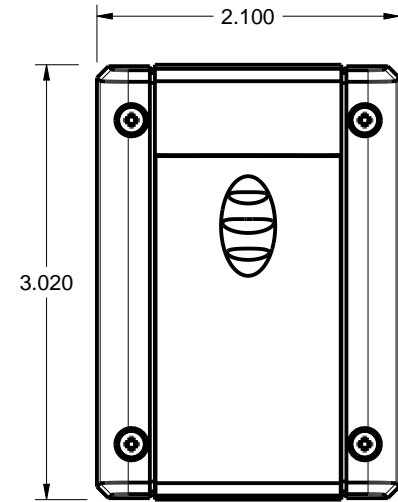
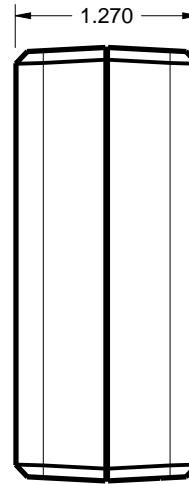
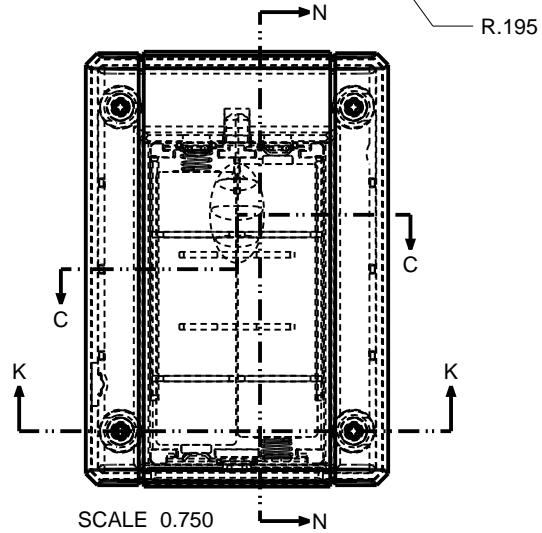
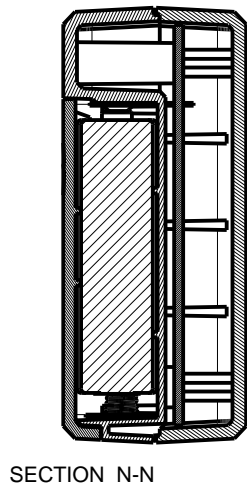
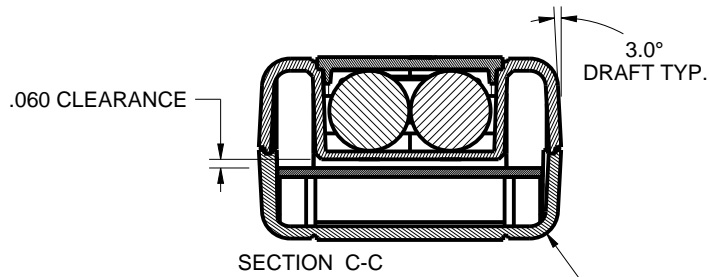

TOLERANCES: UNLESS OTHERWISE SPECIFIED
DIMENSIONS ARE IN U.S. INCHES.
X.XX = .015 X.XXXX = .001
X.XXX = .010 X.X° = 1°

NEW AGE ENCLOSURES

Customer's Part No: 302112

APPROVAL BY DATE

CHECK

ENG.

SCALE AS NOTED

DRAWN BY M BOYER 21-Nov-09

NEW AGE ENCLOSURES

4330 Santa Fe Road San Luis Obispo, CA. 93401
ph. (805) 595-1310 fax (805) 595-1024
www.newageenclosures.com

STANDARD - MINI AA
SXX-302112X-XXX

SIZE A DRAWING NAME 302112_R6_0

SHEET 2 OF 9 REV.DOC 6.0

302112 - COVER

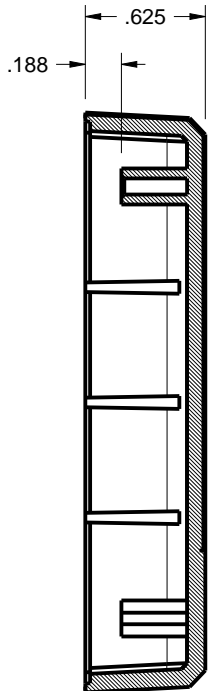
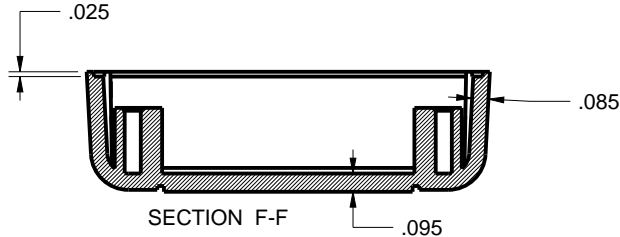

302112 STANDARD SECTION D-D

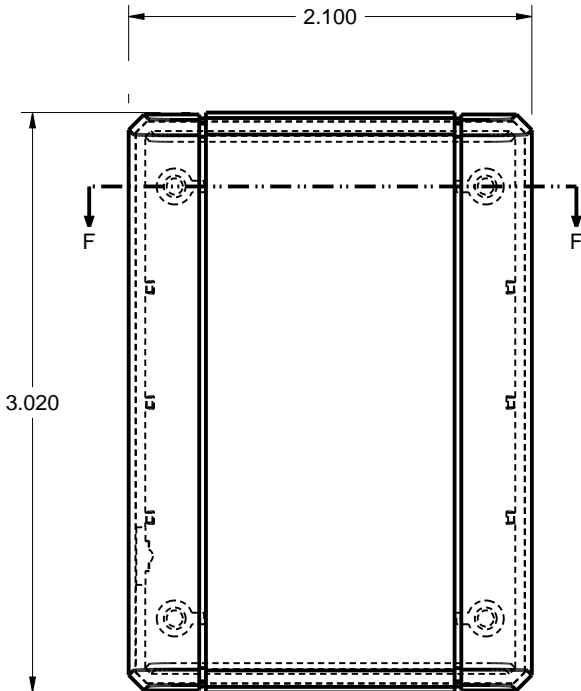

SCALE 1.000

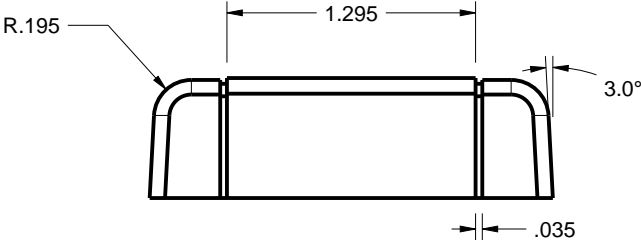
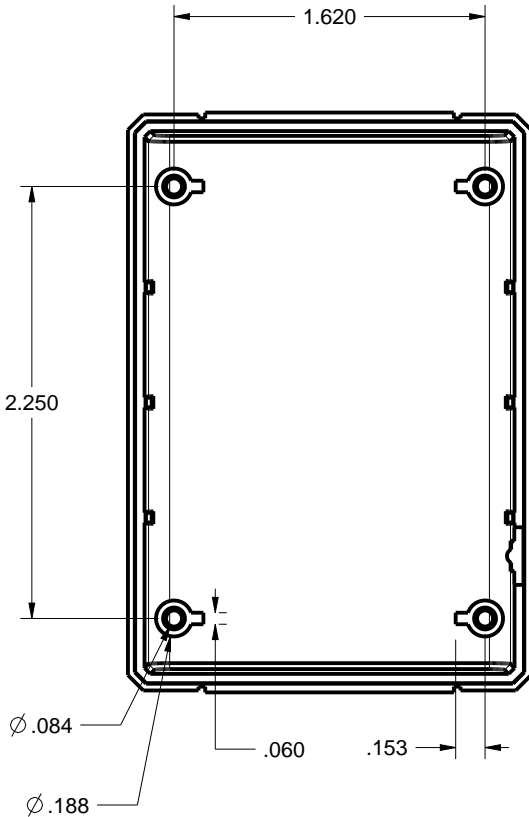
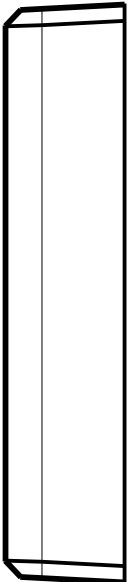

TOLERANCES: UNLESS OTHERWISE SPECIFIED DIMENSIONS ARE IN U.S. INCHES.
 X.XX = .015 X.XXXX = .001
 X.XXX = .010 X.X° = 1°

NEW AGE ENCLOSURES
 Customer's Part No: 302112

| | | |
|----------|-----------|------|
| APPROVAL | BY | DATE |
| CHECK | | |
| ENG. | | |
| SCALE | AS NOTED | |
| DRAWN BY | M BOYER | |
| | 21-Nov-09 | |

NEW AGE ENCLOSURES
 4330 Santa Fe Road San Luis Obispo, CA. 93401
 ph. (805) 595-1310 fax (805) 595-1024
www.newageenclosures.com

STANDARD - MINI AA
 SXX-302112X-XXX

| | | | |
|------|--------------|--------|---------|
| SIZE | DRAWING NAME | SHEET | REV.DOC |
| A | 302112_R6_0 | 3 OF 9 | 6.0 |

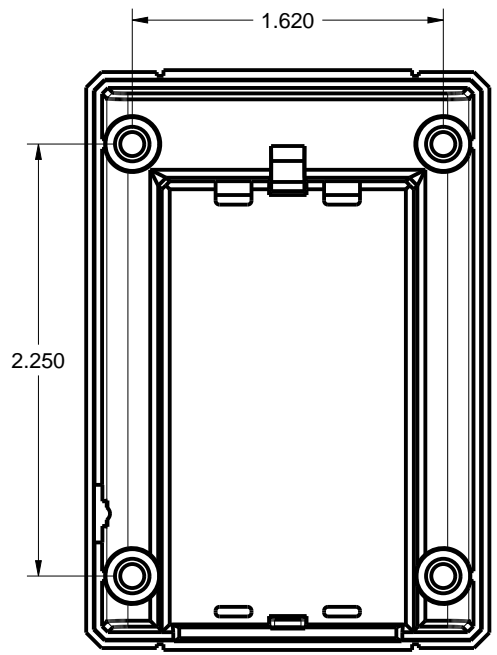
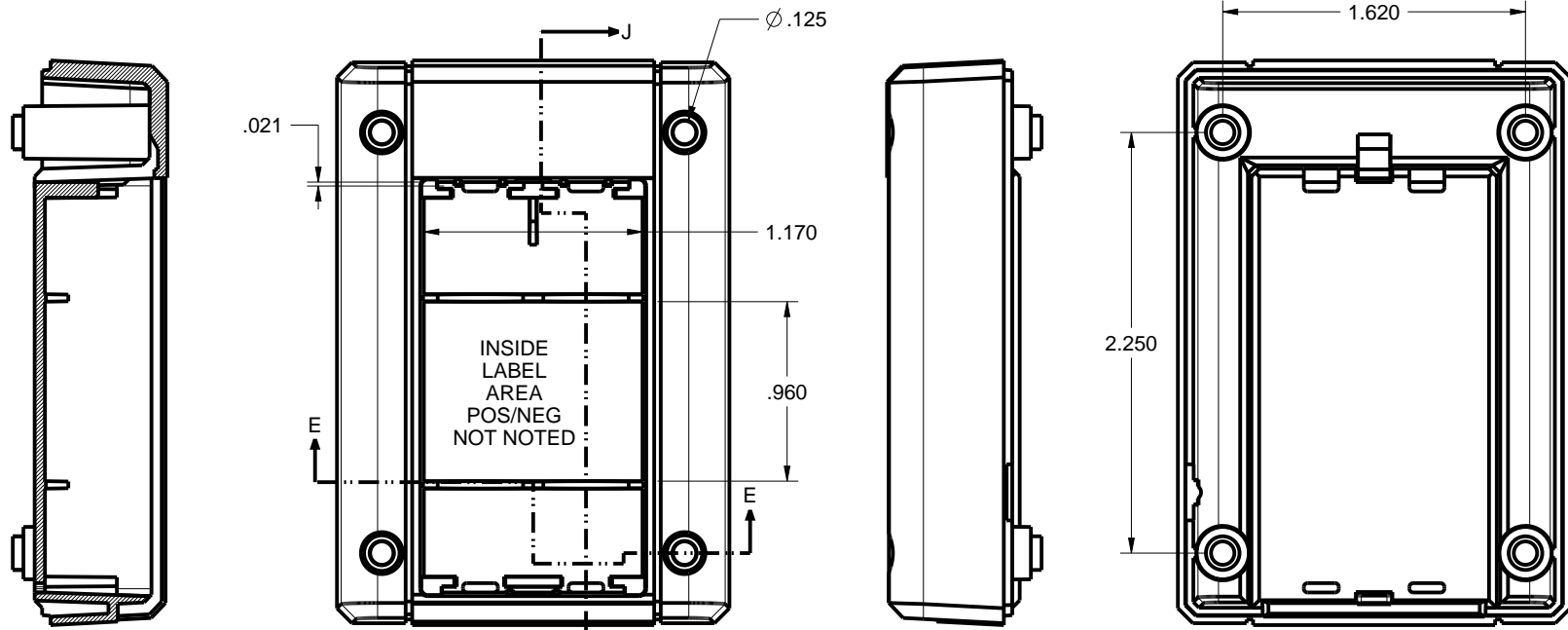
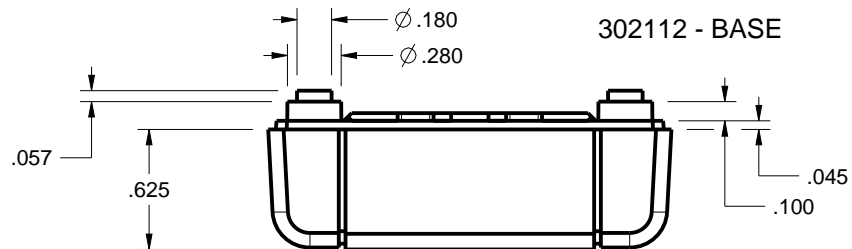

SECTION J-J

SCALE 1.000

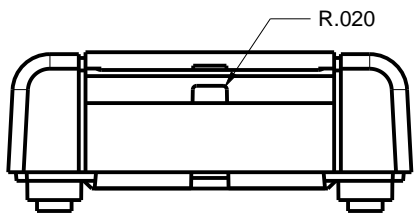
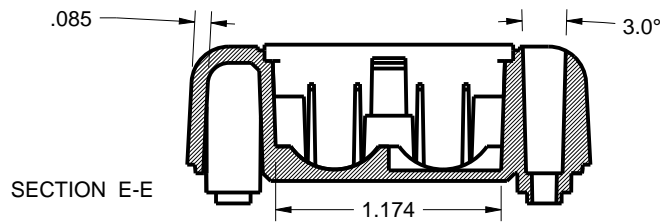

TOLERANCES: UNLESS OTHERWISE SPECIFIED
DIMENSIONS ARE IN U.S. INCHES.

X.XX = .015 X.XXXX = .001
X.XXX = .010 X.X° = 1°

NEW AGE ENCLOSURES
Customer's Part No: 302112

| | | |
|----------|-----------|------|
| APPROVAL | BY | DATE |
| CHECK | | |
| ENG. | | |
| SCALE | AS NOTED | |
| DRAWN BY | 21-Nov-09 | |
| M BOYER | | |

NEW AGE ENCLOSURES
4330 Santa Fe Road San Luis Obispo, CA. 93401
ph. (805) 595-1310 fax (805) 595-1024
www.newageenclosures.com

STANDARD - MINI AA
SXX-302112X-XXX

| | | | |
|------|--------------|--------|---------|
| SIZE | DRAWING NAME | SHEET | REV.DOC |
| A | 302112_R6_0 | 4 OF 9 | 6.0 |

302112 - HATCH

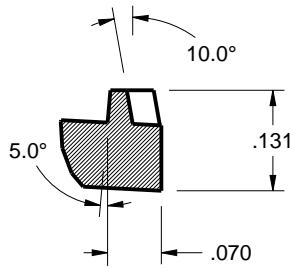

DETAIL C
SCALE 4.000

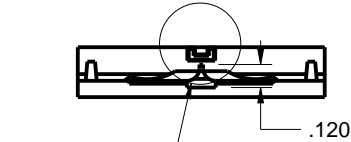

SEE DETAIL B

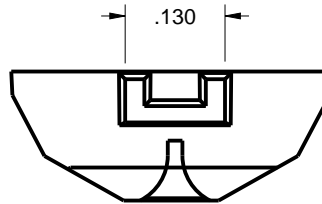

DETAIL B
SCALE 4.000

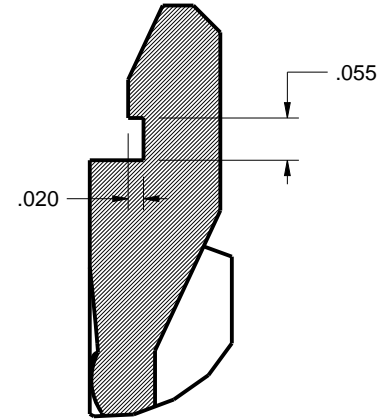

DETAIL D
SCALE 4.000

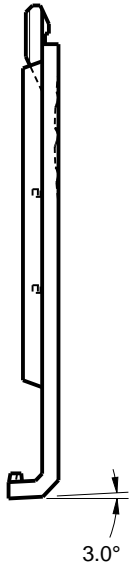

3.0°

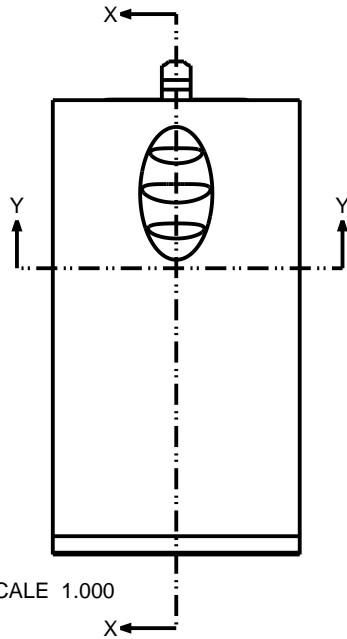

SCALE 1.000

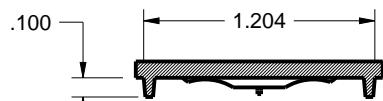

SECTION Y-Y

.040 +5° DRAFT/SIDE

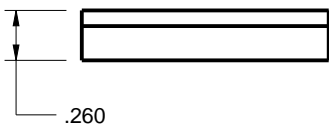

.260

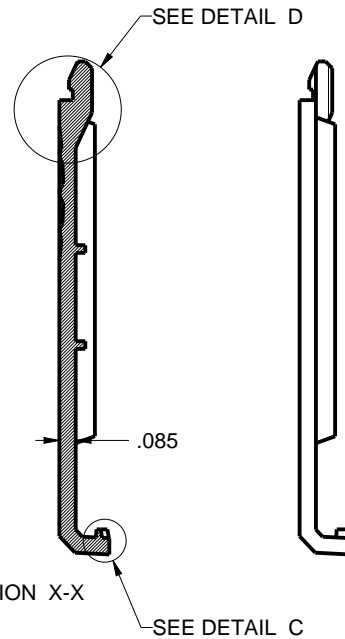

SECTION X-X

SEE DETAIL C

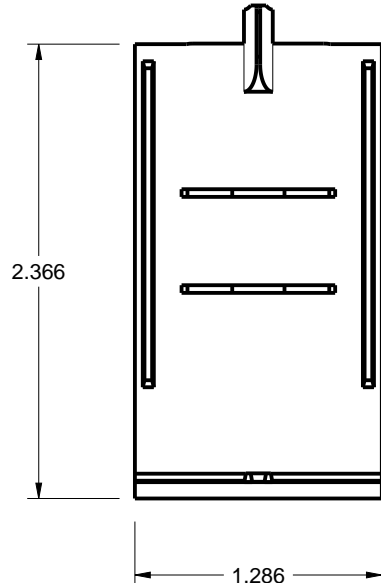

2.366

1.286

TOLERANCES: UNLESS OTHERWISE SPECIFIED
DIMENSIONS ARE IN U.S. INCHES.

X.XX = .015 X.XXXX = .001
X.XXX = .010 X.X° = 1°

NEW AGE ENCLOSURES

Customer's Part No: 302112

APPROVAL BY DATE

CHECK

ENG.

SCALE AS NOTED

DRAWN BY M BOYER

21-Nov-09

NEW AGE ENCLOSURES

4330 Santa Fe Road San Luis Obispo, CA. 93401
ph. (805) 595-1310 fax (805) 595-1024

www.newageenclosures.com

STANDARD - MINI AA
SXX-302112X-XXX

SIZE A DRAWING NAME 302112_R6_0

SHEET 5 OF 9

REV.DOC 6.0

302112 - WALL CRADLE

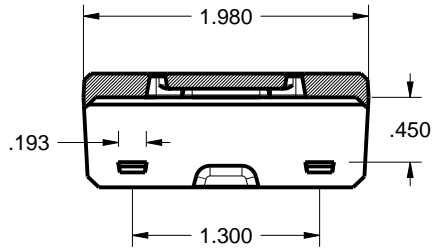

SECTION Y-Y

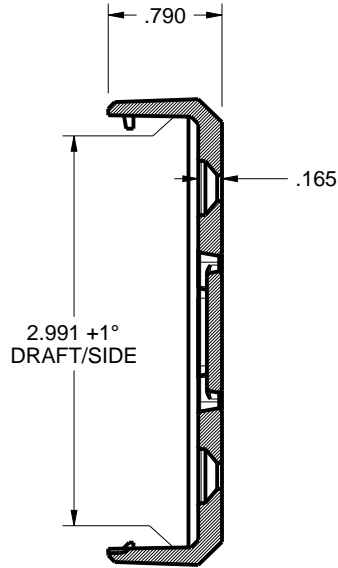

SECTION X-X

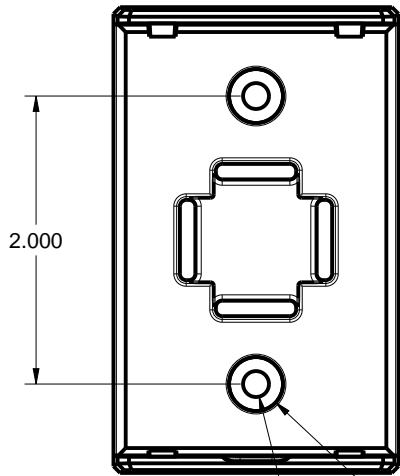
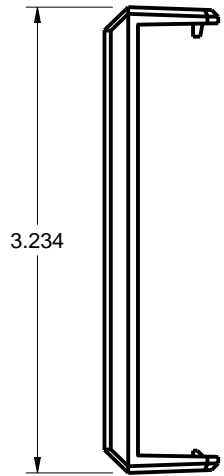

$\phi .180$ $\phi .374$

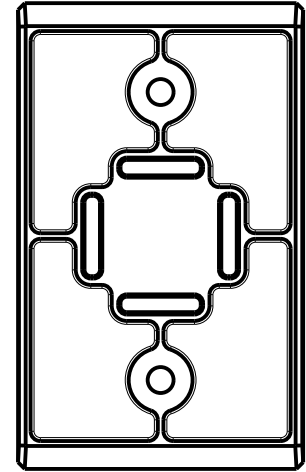
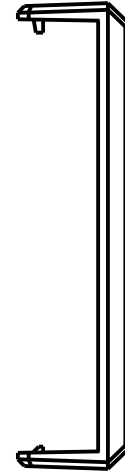

2nd OPERATION REQUIRED
ON 302112 BASE
TO ACCEPT CRADLE TABS

SCALE 0.750

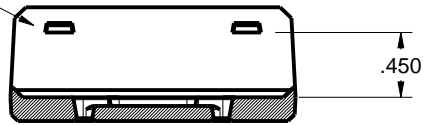

SECTION Y-Y

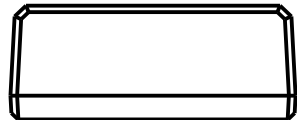

TOLERANCES: UNLESS OTHERWISE SPECIFIED
DIMENSIONS ARE IN U.S. INCHES.
X.XX = .015 X.XXXX = .001
X.XXX = .010 X.X° = 1°

NEW AGE ENCLOSURES

Customer's Part No: 302112

| | | |
|----------|----------|------|
| APPROVAL | BY | DATE |
| CHECK | | |
| ENG. | | |
| SCALE | AS NOTED | |

DRAWN BY
M BOYER 21-Nov-09

NEW AGE ENCLOSURES

4330 Santa Fe Road San Luis Obispo, CA. 93401
ph. (805) 595-1310 fax (805) 595-1024
www.newageenclosures.com

STANDARD - MINI AA
SXX-302112X-XXX

SIZE A DRAWING NAME 302112_R6_0

SHEET 6 OF 9 REV.DOC 6.0

302112 - PCB

PCB SIZES ARE RECOMMENDATIONS ONLY. FINAL SIZES AND VERIFICATION OF ITS FIT ARE THE SOLE RESPONSIBILITY OF THE OEM.

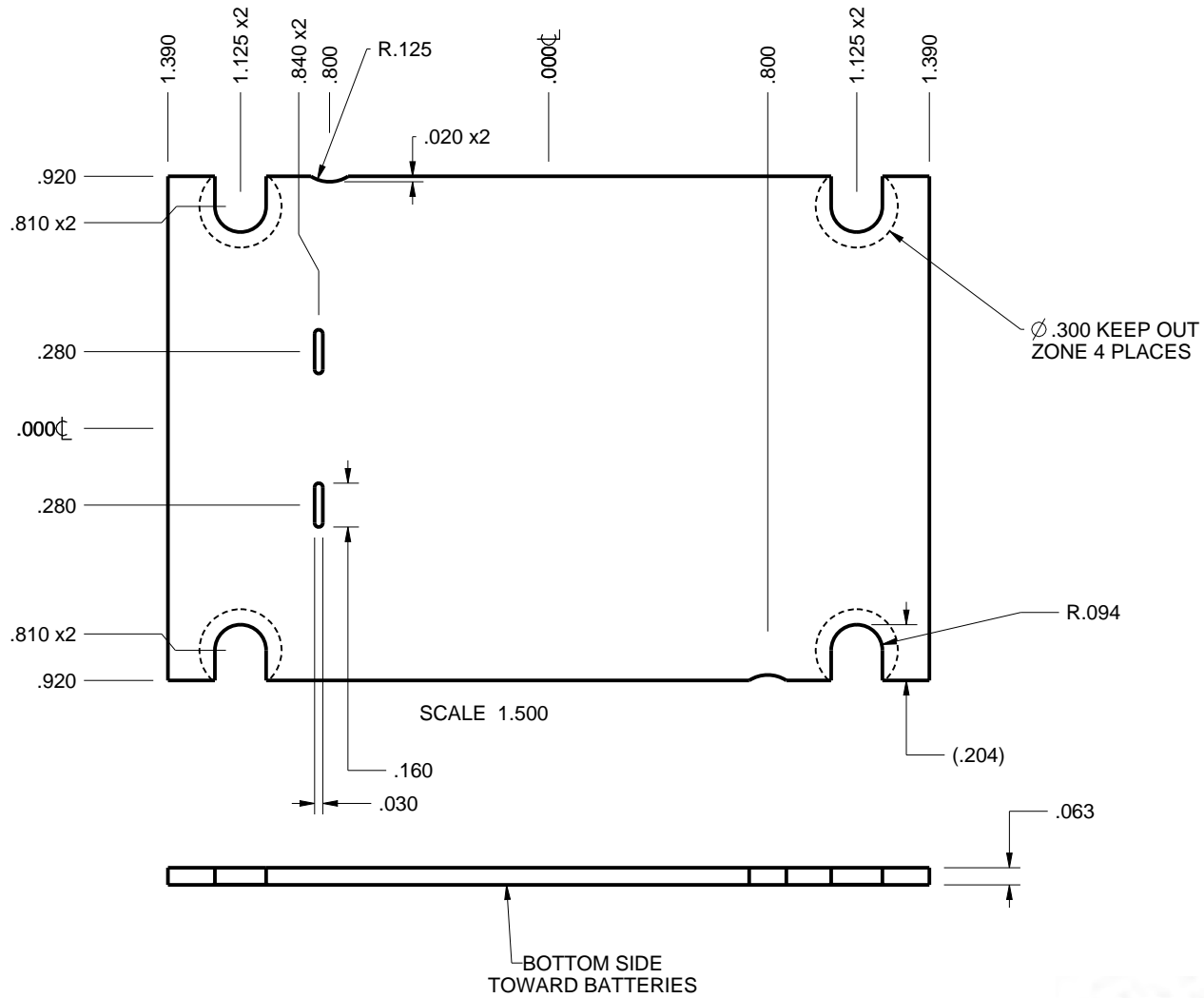

TOLERANCES: UNLESS OTHERWISE SPECIFIED
DIMENSIONS ARE IN U.S. INCHES.
X.XX = .015 X.XXXX = .001
X.XXX = .010 X.X° = 1°

NEW AGE ENCLOSURES
Customer's Part No: 302112

| | | |
|----------|----------|------|
| APPROVAL | BY | DATE |
| CHECK | | |
| ENG. | | |
| SCALE | AS NOTED | |

| | |
|----------|-----------|
| DRAWN BY | 21-Nov-09 |
| M BOYER | |

NEW AGE ENCLOSURES
4330 Santa Fe Road San Luis Obispo, CA. 93401
ph. (805) 595-1310 fax (805) 595-1024
www.newageenclosures.com

STANDARD - MINI AA
SXX-302112X-XXX

| | | | |
|------|--------------|--------|---------|
| SIZE | DRAWING NAME | SHEET | REV.DOC |
| A | 302112_R6_0 | 7 OF 9 | 6.0 |

2nd OPERATION DETAILS - Page 1 of 2
 NEW AGE ENCLOSURES DELIVERS YOUR ENCLOSURE MARKET-READY WITH IN-HOUSE
 CNC MACHINING, PAD PRINTING, ASSEMBLY, AND FULFILLMENT.
 ALL SURFACES AND AREAS ARE AVAILABLE FOR CNC ALTERATION BY NEW AGE ENCLOSURES
 CALL (805) 595-1310 FOR PRICING AND SCHEDULE.
 THE INSIDE RADIUS OF ANY MACHINED FEATURES SHOULD BE NO SMALLER THAN .031"

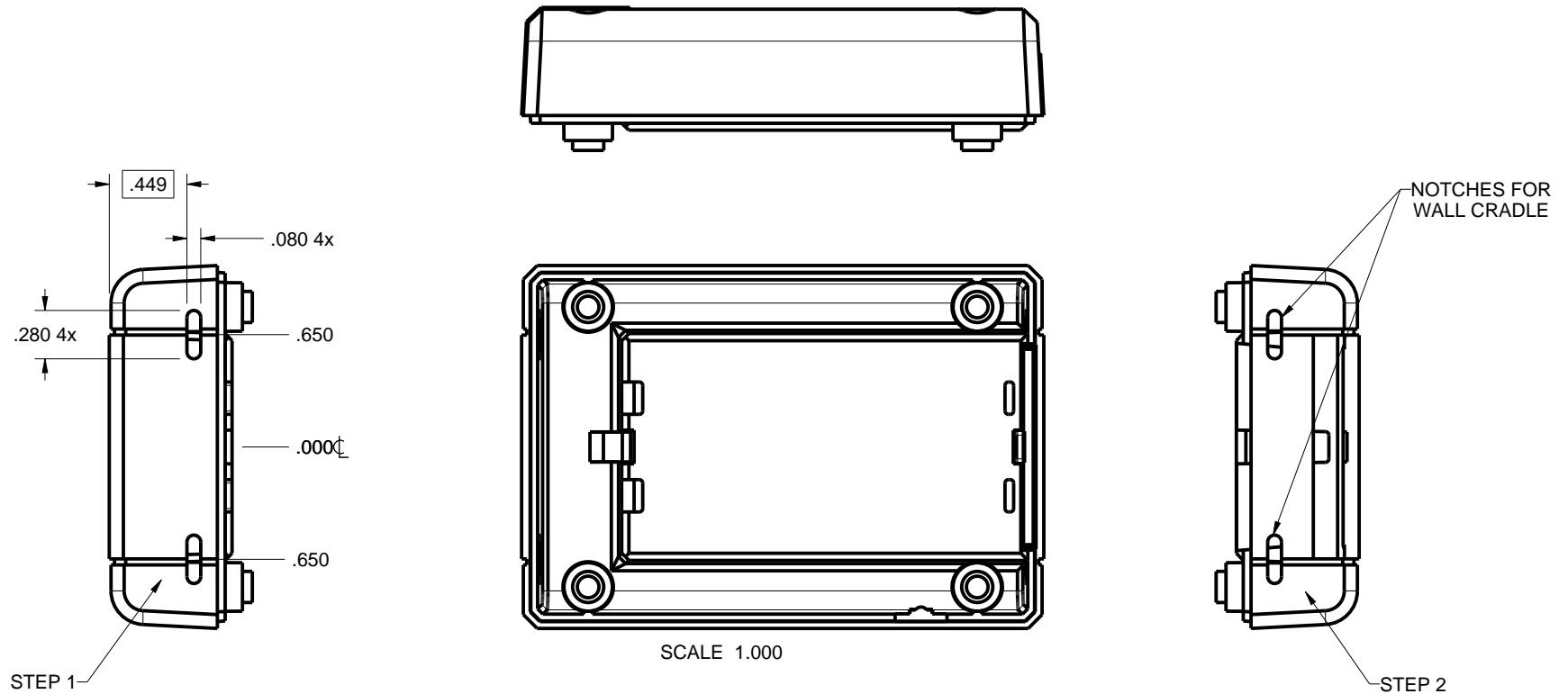

TOLERANCES: UNLESS OTHERWISE SPECIFIED
 DIMENSIONS ARE IN U.S. INCHES.
 X.XX = .015 X.XXXX = .001
 X.XXX = .010 X.X° = 1°

NEW AGE ENCLOSURES
 4330 Santa Fe Road San Luis Obispo, CA. 93401
 ph. (805) 595-1310 fax (805) 595-1024

Customer's Part No: 302112

www.newageenclosures.com

STANDARD - MINI AA
SXX-302112X-XXX

| SXX-302112X-XXX BASE - ABS, BLACK | | | | | |
|-----------------------------------|----------------|---------------|---------|-------------|---------|
| STEP NO | DESCRIPTION | CUTTER | FIXTURE | ORIENTATION | PROGRAM |
| 1-C-C1 | CRADLE NOTCHES | T2 = .062" EM | 193 | SINGLE | - |
| 2-C-C2 | CRADLE NOTCHES | T2 = .062" EM | 193 | SINGLE | - |

| | | |
|----------|-----------|------|
| APPROVAL | BY | DATE |
| CHECK | | |
| ENG. | | |
| SCALE | AS NOTED | |
| DRAWN BY | 21-Nov-09 | |
| M BOYER | | |

| | | | |
|------|--------------|--------|---------|
| SIZE | DRAWING NAME | SHEET | REV.DOC |
| A | 302112_R6_0 | 8 OF 9 | 6.0 |

2nd OPERATION DETAILS - Page 2 of 2
 NEW AGE ENCLOSURES DELIVERS YOUR ENCLOSURE MARKET-READY WITH IN-HOUSE
 CNC MACHINING, PAD PRINTING, ASSEMBLY, AND FULFILLEMENT.
 ALL SURFACES AND AREAS ARE AVAILABLE FOR CNC ALTERATION BY NEW AGE ENCLOSURES
 CALL (805) 595-1310 FOR PRICING AND SCHEDULE.
 THE INSIDE RADIUS OF ANY MACHINED FEATURES SHOULD BE NO SMALLER THAN .031"

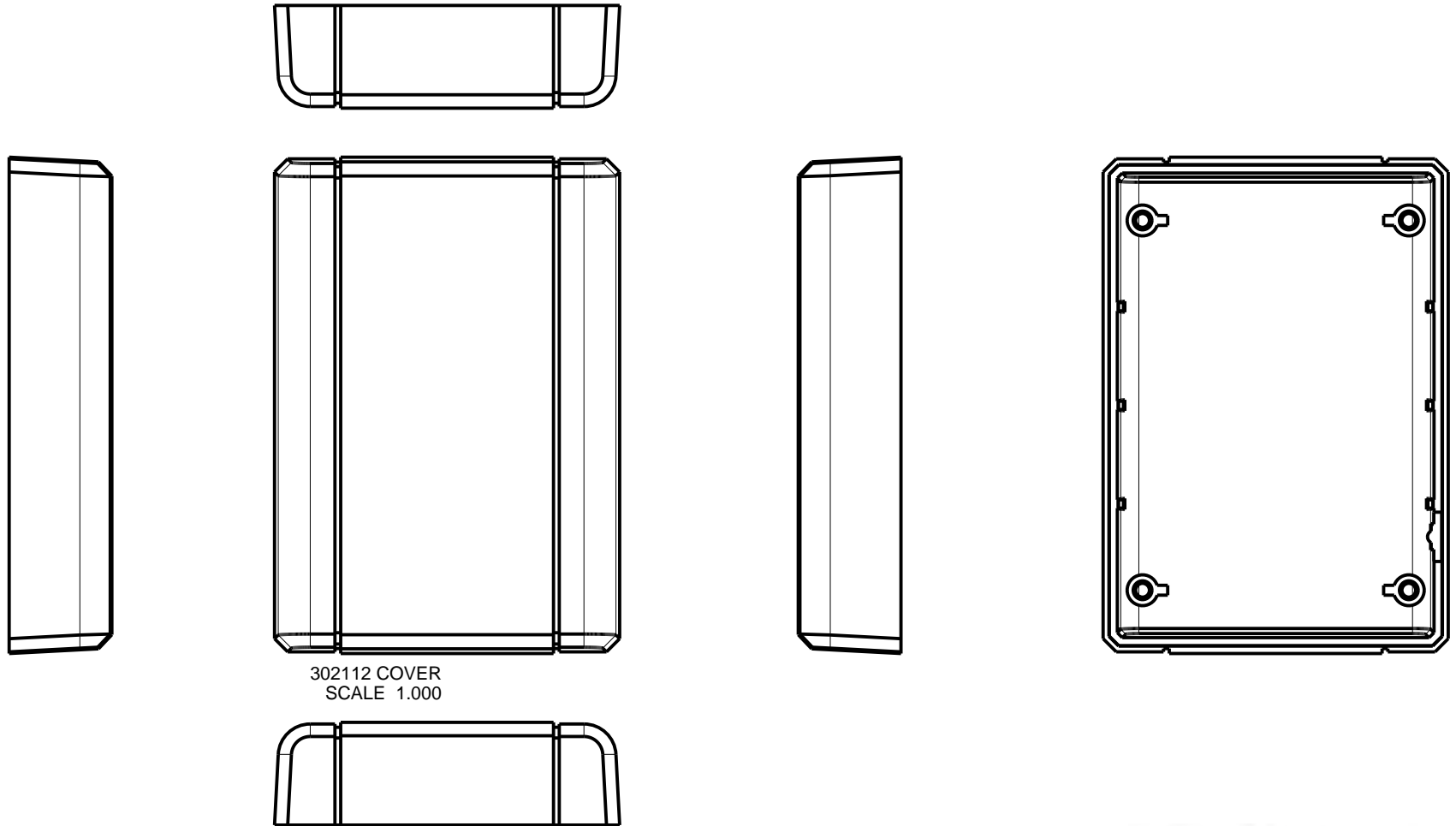

302112 COVER
 SCALE 1.000

| SXX-302112X-XXX COVER - ABS, BLACK | | | | | |
|------------------------------------|-------------|---------------|---------|-------------|---------|
| STEP NO | DESCRIPTION | CUTTER | FIXTURE | ORIENTATION | PROGRAM |
| 1-C-C1 | - | T2 = .062" EM | 193 | SINGLE | |
| 2-C-C2 | - | T2 = .062" EM | 193 | - | |
| 3-C-C3 | - | T2 = .062" EM | 193 | - | |

| | | | |
|---|-----------|---|-----------------------------|
| TOLERANCES: UNLESS OTHERWISE SPECIFIED DIMENSIONS ARE IN U.S. INCHES. X.XX = .015 X.XXXX = .001 X.XXX = .010 X.X° = 1° | | NEW AGE ENCLOSURES 4330 Santa Fe Road San Luis Obispo, CA. 93401 ph. (805) 595-1310 fax (805) 595-1024 www.newageenclosures.com | |
| NEW AGE ENCLOSURES Customer's Part No: 302112 | | | |
| APPROVAL BY DATE CHECK _____ ENG. _____ SCALE AS NOTED | | STANDARD - MINI AA SXX-302112X-XXX | |
| DRAWN BY M BOYER | 21-Nov-09 | SIZE A | DRAWING NAME 302112_R6_0 |
| | | SHEET 9 OF 9 | REV.DOC 6.0 |

Mouser Electronics

Authorized Distributor

Click to View Pricing, Inventory, Delivery & Lifecycle Information:

[New Age Enclosures:](#)

[S1A-302112](#) [S3A-302112](#) [S1A-302112-K](#) [S3A-302112-K](#)

Компания «Life Electronics» занимается поставками электронных компонентов импортного и отечественного производства от производителей и со складов крупных дистрибьюторов Европы, Америки и Азии.

С конца 2013 года компания активно расширяет линейку поставок компонентов по направлению коаксиальный кабель, кварцевые генераторы и конденсаторы (керамические, пленочные, электролитические), за счёт заключения дистрибьюторских договоров

Мы предлагаем:

- Конкурентоспособные цены и скидки постоянным клиентам.
- Специальные условия для постоянных клиентов.
- Подбор аналогов.
- Поставку компонентов в любых объемах, удовлетворяющих вашим потребностям.
- Приемлемые сроки поставки, возможна ускоренная поставка.
- Доставку товара в любую точку России и стран СНГ.
- Комплексную поставку.
- Работу по проектам и поставку образцов.
- Формирование склада под заказчика.
- Сертификаты соответствия на поставляемую продукцию (по желанию клиента).
- Тестирование поставляемой продукции.
- Поставку компонентов, требующих военную и космическую приемку.
- Входной контроль качества.
- Наличие сертификата ISO.

В составе нашей компании организован Конструкторский отдел, призванный помогать разработчикам, и инженерам.

Конструкторский отдел помогает осуществить:

- Регистрацию проекта у производителя компонентов.
- Техническую поддержку проекта.
- Защиту от снятия компонента с производства.
- Оценку стоимости проекта по компонентам.
- Изготовление тестовой платы монтаж и пусконаладочные работы.



Тел: +7 (812) 336 43 04 (многоканальный)

Email: org@lifeelectronics.ru