

Data Sheet

ASX11504-SW-R

PUI Audio's **ASX11504-SW-R** silent subwoofer exciter, also referred to as a tactile transducer, is purpose-built to recreate ultra-low frequencies from 500 Hz all the way down to 5 Hz! It delivers all the bass, without much space, and with nearly none of the sound. Perfect for surround sound systems and gaming!

Instead of using a cone or diaphragm to move air, the electro-mechanical motor is designed to directly couple to a surface (such as the frame of a chair or sofa) to transmit vibrational energy from the motor into the mounting surface, exciting deep tissue muscles (kinesthetic senses), skeletal nerve endings (haptic senses), and transmitting sound through bone conduction.

Tactile transducers can also be used to replace vibrational motors in industrial and medical applications where multi-frequency haptics are required.

Features:

- Installs in minutes with spring-loaded push terminals and mounting holes
- 4 ohm impedance and high 50W continuous power rating
- Creates bass without sound, perfect for home theater, industrial, and medical applications
- Able to create almost 90 Newtons of force

Specifications

Parameters	Values	Units
Rated Input Power	50	Watts
Max Input Power	100	Watts
Impedance	4 ± 15%	Ohms
Resonant Frequency	35± 20%	Hz
Frequency Range	5 ~ 500	Hz
Housing Material	Aluminum	-
Magnet Material	NdFeB	-
Weight	780	Grams
Operating Temperature	-20 ~ +60	°C

Impedance Response

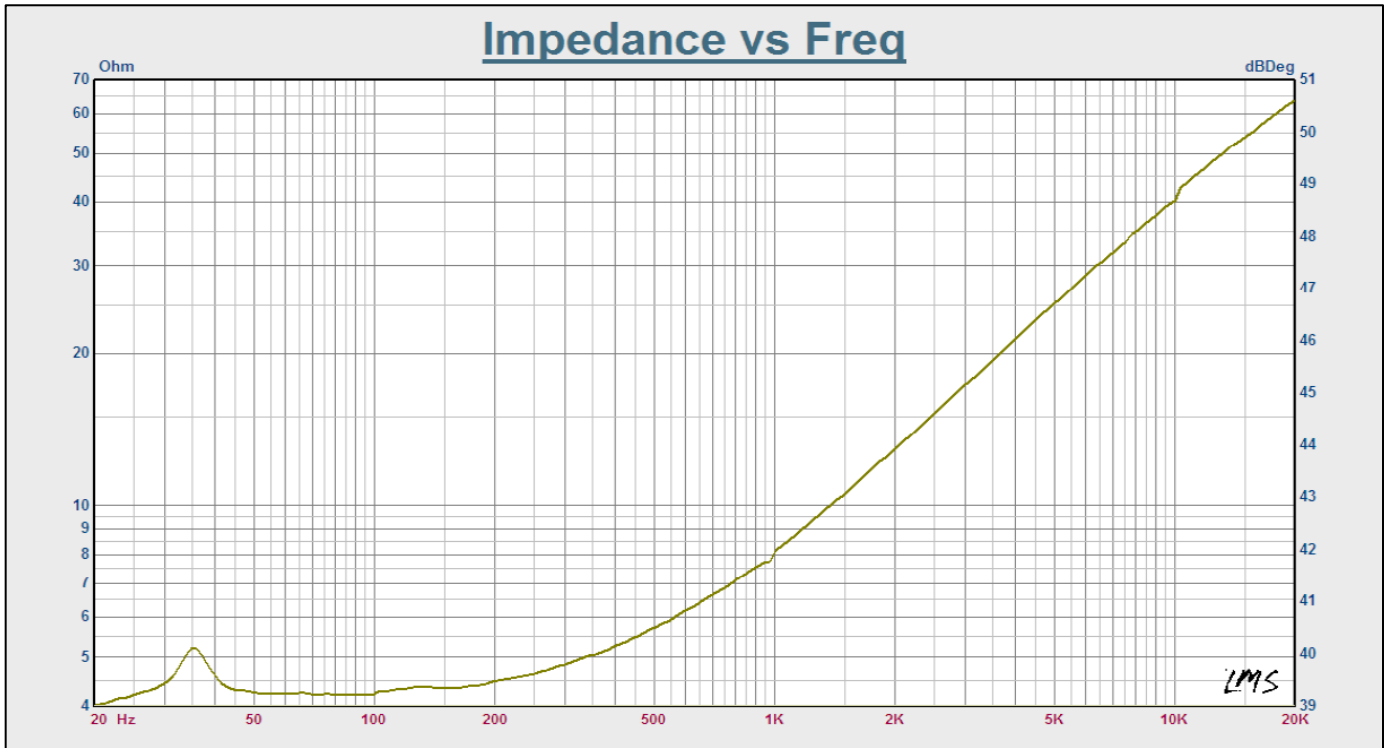

Reliability Testing

Type of Test	Test Specifications
High Temperature Test	24 hours at +60°C ± 2°C followed by three hours in normal room temperature
Low Temperature Test	1 hour at -10°C ± 3°C followed by 2 hours at -20°C ± 3°C
Humidity Test	48 hours at +40°C ± 2°C with relative humidity at 93% followed by 6 hours in normal room temperature
Drop Test	600mm ±25mm at 60°±5°
Load Test	IEC 268-5 14.14V for 8 hours

Dimensions (Red terminal is positive)

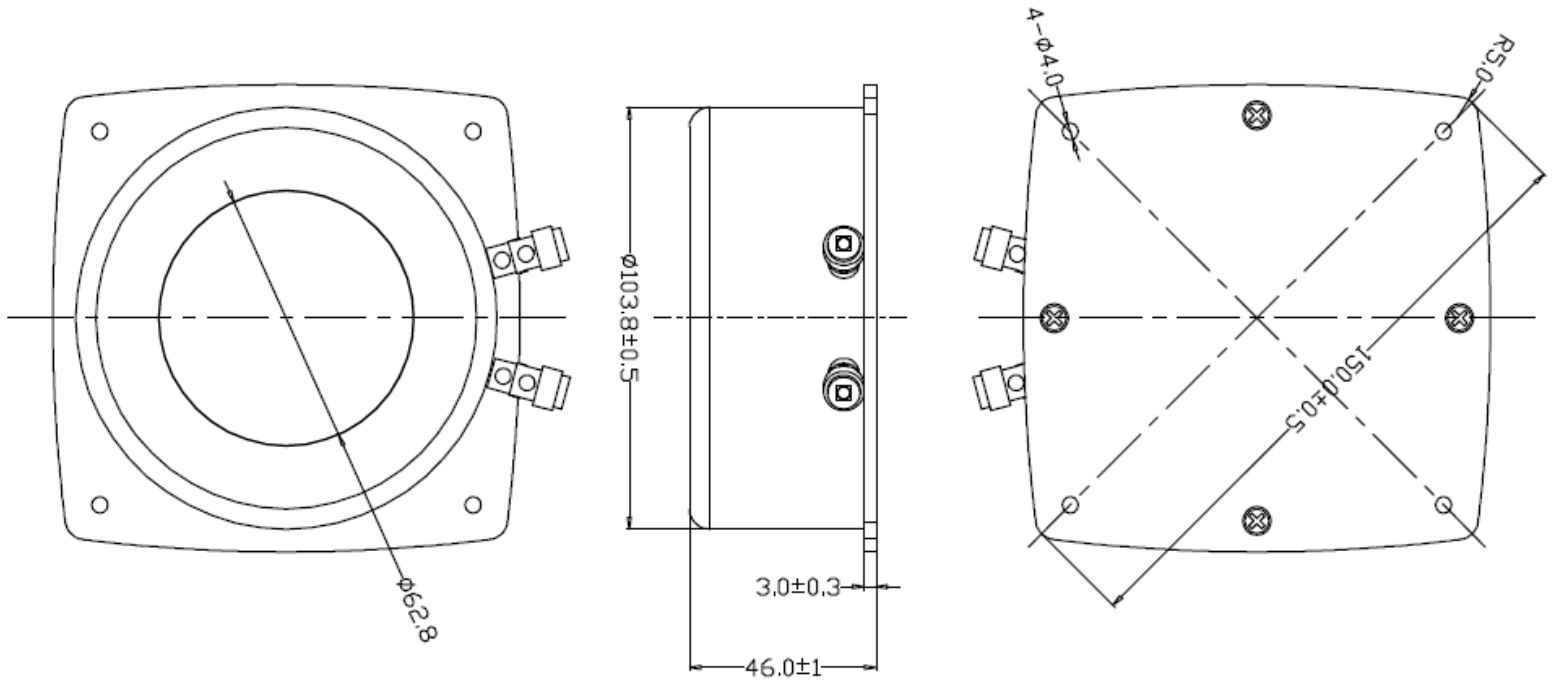

Cutaway View

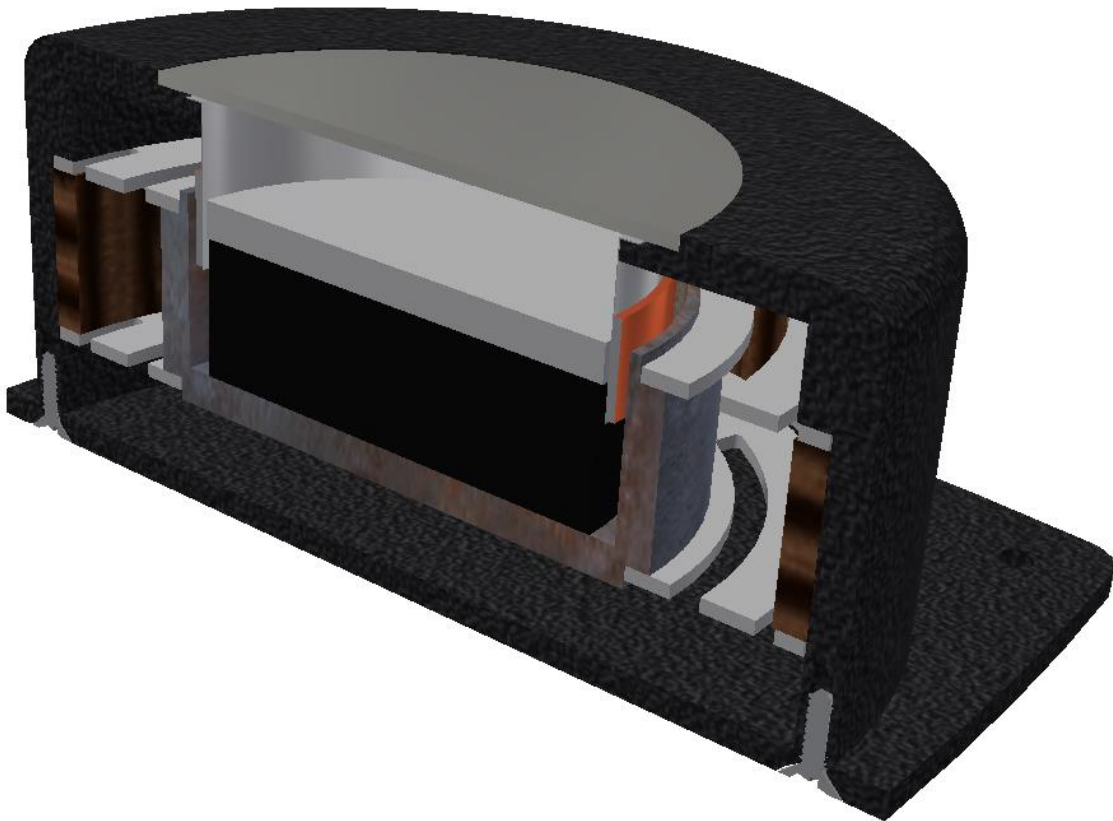

Using Silent Subwoofer eXciter

Placement

Using a PUI Audio Silent Subwoofer eXciter is straightforward. Simply mount the flat base of the eXciter to the bottom of a chair or couch. For best performance, one eXciter should be used per seating location, with placement directly under the user's spine and the eXciter attached directly to the frame of the chair or couch.



ASX11504-SW-R attached to an office chair for gaming applications

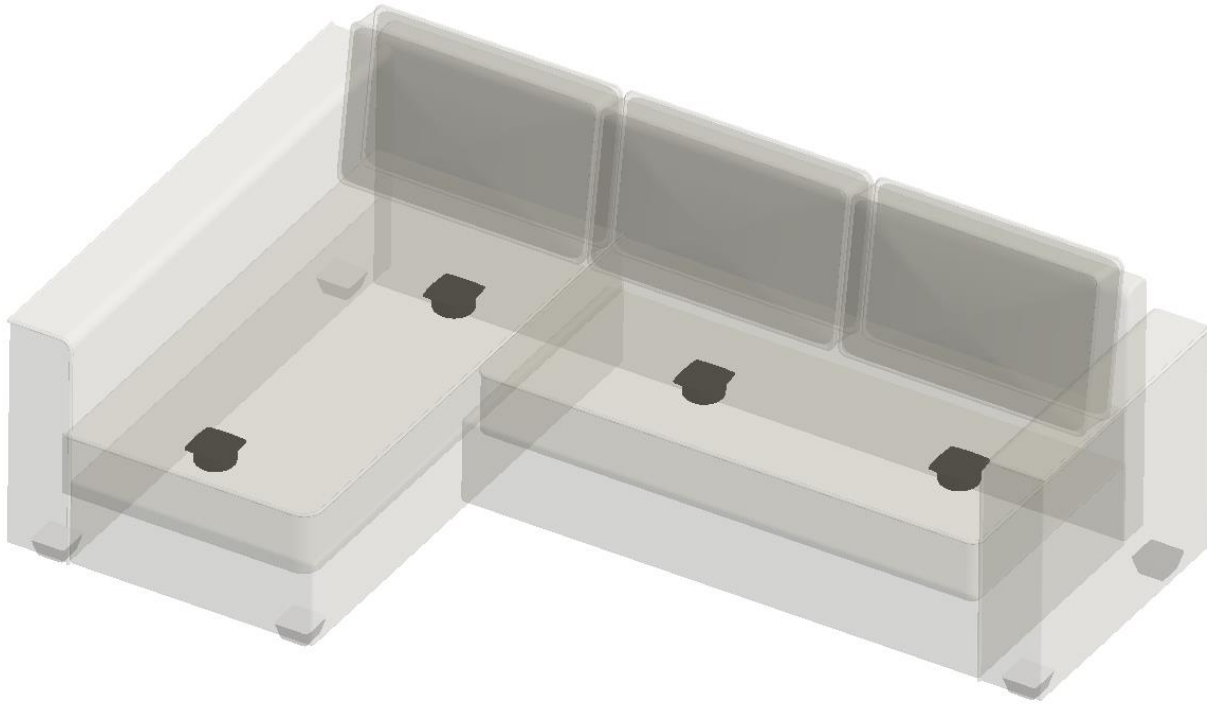

ASX11504-SW-R attached to a sofa for home theater applications

In some applications, the eXciter may transmit sound through the furniture it is installed on. If this occurs, place rubber bumpers under each foot on the piece of furniture for mechanical isolation.

Wiring and Amplifier Connection

Ideally it is best to power each eXciter with a dedicated amplifier. If that is not possible, and only one amplifier is available, we recommend ensuring the amplifier can provide adequate power for the total number of eXcitors being used.

In the sofa example above, four eXcitors would need between 200 and 400 total watts. To maintain a 4-ohm impedance to the amplifier, wire the eXcitors series-parallel as shown below. For best performance, the amplifier input should be connected to the LFE or subwoofer channel of your receiver, PC, or signal source.

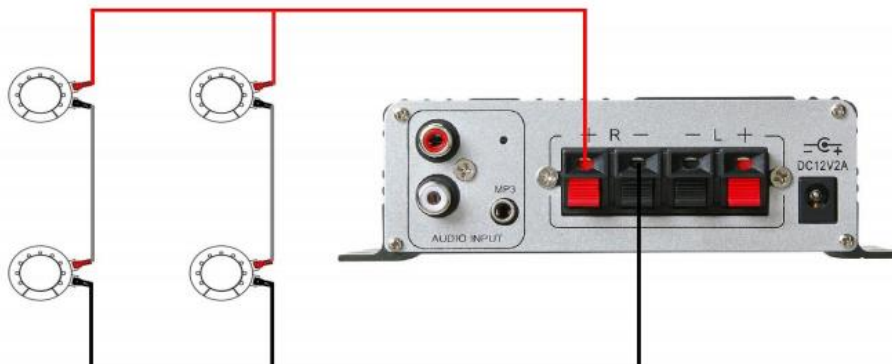

Specifications Revisions

Revision	Description	Date
-	Released from Engineering	12/20/2018

Note:

1. Unless otherwise specified:
 - A. All dimensions are in millimeters.
 - B. Default tolerances are $\pm 0.5\text{mm}$ and angles are $\pm 3^\circ$.
2. Specifications subject to change or withdrawal without notice.
3. This part is RoHS 2011/65/EU Compliant.

Компания «Life Electronics» занимается поставками электронных компонентов импортного и отечественного производства от производителей и со складов крупных дистрибьюторов Европы, Америки и Азии.

С конца 2013 года компания активно расширяет линейку поставок компонентов по направлению коаксиальный кабель, кварцевые генераторы и конденсаторы (керамические, пленочные, электролитические), за счёт заключения дистрибьюторских договоров

Мы предлагаем:

- Конкурентоспособные цены и скидки постоянным клиентам.
- Специальные условия для постоянных клиентов.
- Подбор аналогов.
- Поставку компонентов в любых объемах, удовлетворяющих вашим потребностям.
- Приемлемые сроки поставки, возможна ускоренная поставка.
- Доставку товара в любую точку России и стран СНГ.
- Комплексную поставку.
- Работу по проектам и поставку образцов.
- Формирование склада под заказчика.
- Сертификаты соответствия на поставляемую продукцию (по желанию клиента).
- Тестирование поставляемой продукции.
- Поставку компонентов, требующих военную и космическую приемку.
- Входной контроль качества.
- Наличие сертификата ISO.

В составе нашей компании организован Конструкторский отдел, призванный помогать разработчикам, и инженерам.

Конструкторский отдел помогает осуществить:

- Регистрацию проекта у производителя компонентов.
- Техническую поддержку проекта.
- Защиту от снятия компонента с производства.
- Оценку стоимости проекта по компонентам.
- Изготовление тестовой платы монтаж и пусконаладочные работы.



Тел: +7 (812) 336 43 04 (многоканальный)

Email: org@lifeelectronics.ru