

# Small Signal IGBT/MOSFET Gate Driver Series

## Two-Channel/Three-Channel Small Signal IGBT/MOSFET Gate Drivers



### BD6562FV-LB, BD6563FV-LB

#### ●General Description

These products guarantee long time support in Industrial market.

These products are the most suitable to use as these applications.

BD6562FV-LB/BD6563FV-LB is 2ch/3ch gate driver to drive gate of IGBT/MOSFET from 3.3V or 5V input signals.

Output signals consist of each high side and low side drive signals in order to make ON/OFF timing control easy. 1 input signal generates 2 output signals which are high side output and low side output signal for 1 channel drive. High side output signal outputs "H" level and high impedance and low side output signal outputs "L" signal and high impedance.

#### ●Features

- Long Time Support Product for Industrial Applications
- Two-Channel/Three-Channel Gate Drivers
- Separated Turn ON and Turn OFF Output

#### ●Applications

- Low-side IGBT/MOSFET Gate Drive for DCDC Converter
- Low-side IGBT/MOSFET Gate Drive for Inverter

#### ●Key Specifications

- Output-side supply voltage(max.): 30V
- Input-side supply voltage: 3.0V to 5.5V
- Output peak current( $\leq 1\mu s$ ):  $\pm 0.6A$
- Input-Output delay time (at VDD=3.3V):380ns(Max.)
- Input-Output delay time (at VDD=5.0V):345ns(Max.)
- Operating temperature range:  $-25^{\circ}C$  to  $+125^{\circ}C$

#### ●Package

SSOP-B16

W(Typ.) x D(Typ.) x H(Max.)

5.00mm x 6.40mm x 1.35mm



#### ●Typical Application Circuit

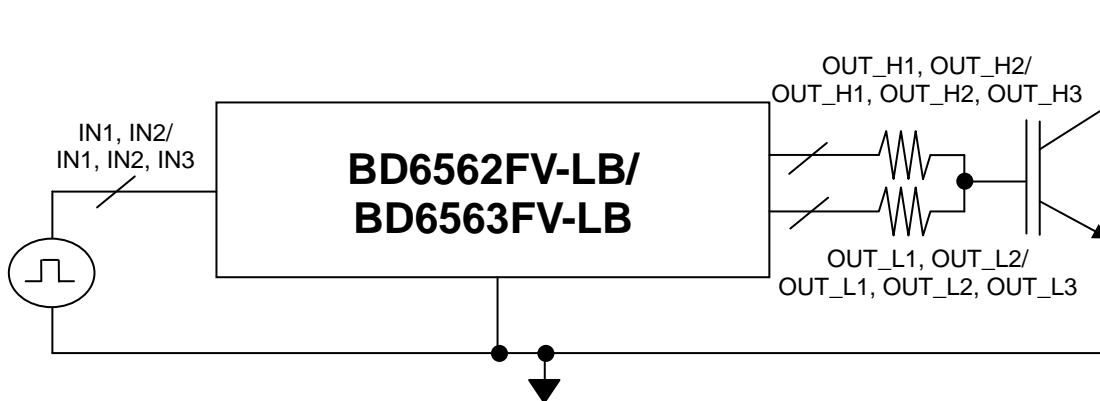

Figure 1. Typical Application Circuit

●Pin Configuration

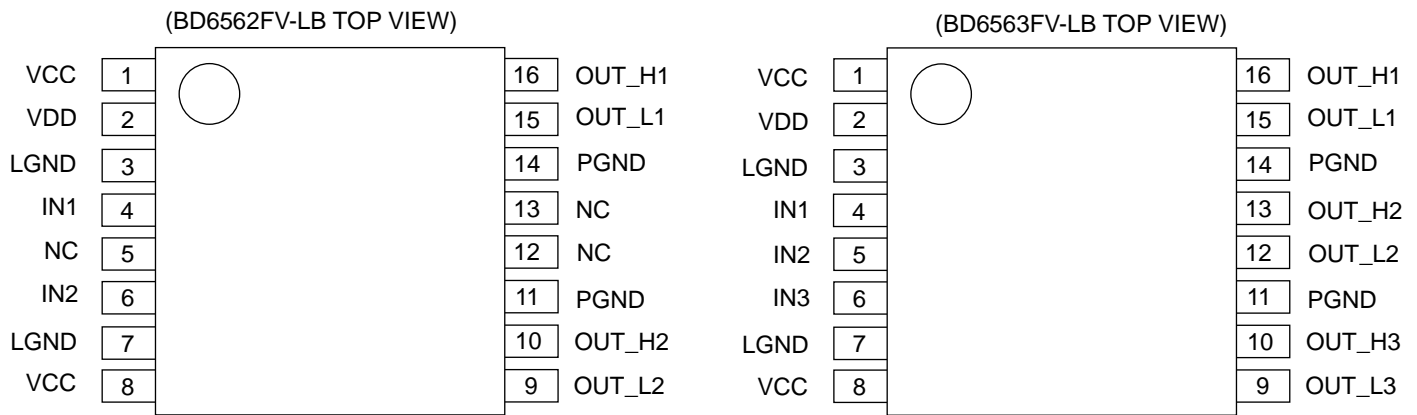

Figure 2. Pin configuration

●Pin Description

**BD6562FV-LB**

Pin No.	Pin Name	Function
1	VCC	Output-side power supply pin
2	VDD	Input-side power supply pin
3	LGND	Input-side ground pin
4	IN1	Control input 1 pin
5	NC	NC
6	IN2	Control input 2 pin
7	LGND	Input-side ground pin
8	VCC	Output-side power supply pin
9	OUT_L2	Low-side output 2 pin
10	OUT_H2	High-side output 2 pin
11	PGND	Output-side ground pin
12	NC	NC
13	NC	NC
14	PGND	Output-side ground pin
15	OUT_L1	Low-side output 1 pin
16	OUT_H1	High-side output 1 pin

**BD6563FV-LB**

Pin No.	Pin Name	Function
1	VCC	Output-side power supply pin
2	VDD	Input-side power supply pin
3	LGND	Input-side ground pin
4	IN1	Control input 1 pin
5	IN2	Control input 2 pin
6	IN3	Control input 3 pin
7	LGND	Input-side ground pin
8	VCC	Output-side power supply pin
9	OUT_L3	Low-side output 3 pin
10	OUT_H3	High-side output 3 pin
11	PGND	Output-side ground pin
12	OUT_L2	Low-side output 2 pin
13	OUT_H2	High-side output 2 pin
14	PGND	Output-side ground pin
15	OUT_L1	Low-side output 1 pin
16	OUT_H1	High-side output 1 pin

●Block Diagram

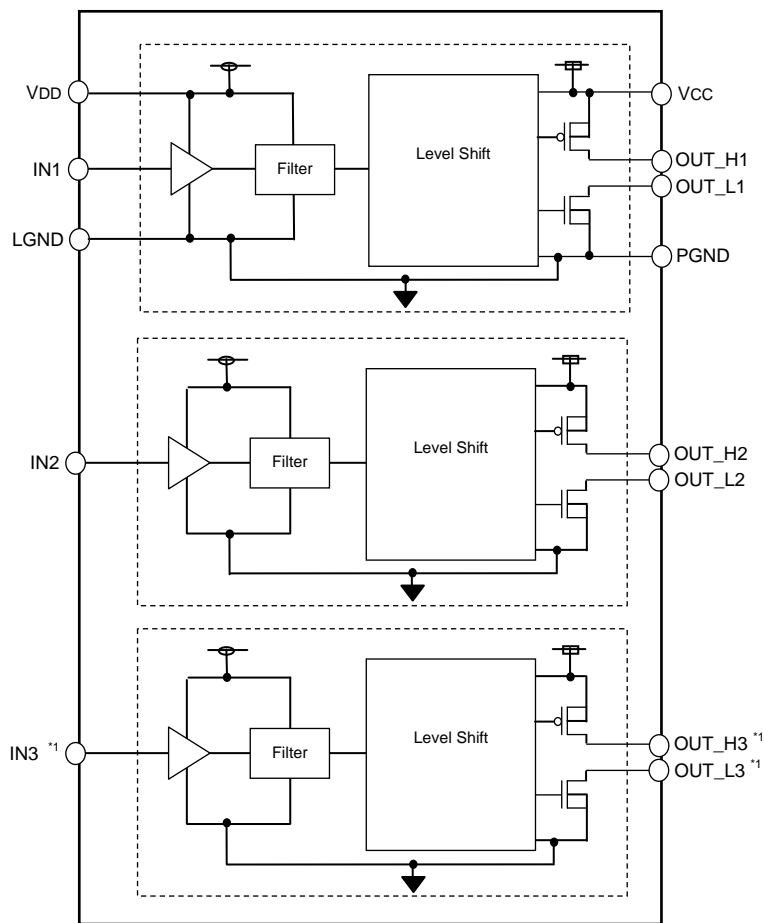

\*1 BD6562FV-LB : There are not IN3, OUT\_H3 and OUT\_L3.

Figure 3. Block Diagram

●Absolute Maximum Ratings

Parameter	Symbol	Limits	Units
Output-side supply voltage	$V_{CCMAX}$	30	V
Input-side supply voltage	$V_{DDMAX}$	7	V
INX <sup>*1</sup> pin input voltage	$V_{INXMAX}$	-0.3 to VDD+0.3	V
OUT_HX / OUT_LX <sup>*1</sup> pin output voltage	$V_{OUTHXMAX}$ $V_{OUTLXMAX}$	-0.3 to VCC+0.3	V
OUT_HX <sup>*1</sup> pin output current (Peak 1us)	$I_{OUTHXMAX}$	-0.6 <sup>*2</sup>	A
OUT_LX <sup>*1</sup> pin output current (Peak 1us)	$I_{OUTLXMAX}$	+0.6 <sup>*2</sup>	A
Power dissipation	$P_d$	0.87 <sup>*3</sup>	W
Operating temperature range	$T_{OPR}$	-25 to +125	°C
Storage temperature range	$T_{stg}$	-55 to +150	°C
Junction temperature	$T_{jmax}$	+150	°C

\*1 BD6562FV-LB : X=1,2  
BD6563FV-LB : X=1,2,3

\*2 Should not exceed Pd and Tj=150°C.

\*3 Derate above Ta=25°C at a rate of 7.0mW/°C. Mounted on a glass epoxy of 70 mm × 70 mm × 1.6 mm.

●Recommended Operating Ratings

Parameter	Symbol	Min.	Max.	Units
Output-side supply voltage	$V_{CC}$	10	25	V
Input-side supply voltage	$V_{DD}$	3.0	5.5	V
INX <sup>*1</sup> high level input voltage	$V_{DD}$	$V_{DD} \times 0.7$	-	V
INX <sup>*1</sup> low level input voltage	$V_{DD}$	-	$V_{DD} \times 0.3$	V

\*1 BD6562FV-LB : X=1,2  
BD6563FV-LB : X=1,2,3

## ● Electrical Characteristics

(Unless otherwise specified  $T_a = -25^\circ\text{C}$  to  $125^\circ\text{C}$ ,  $V_{DD} = 3.0\text{V}$  to  $5.5\text{V}$ ,  $V_{CC} = 10\text{V}$  to  $25\text{V}$ )

Parameter	Symbol	Min.	Typ.	Max.	Unit	Conditions
INX *1 pull-down resistance	$R_{INX}^{*1}$	25	50	100	k $\Omega$	
Output-side circuit current 1	$I_{CC1}$	-	0.32	1	mA	IN1=IN2=IN3=0V *2
Output-side circuit current 2	$I_{CC2}$	-	0.43	1	mA	IN1=IN2=IN3=25kHz *2, Duty=50%
Input-side circuit current 1	$I_{DD1}$	-	0	10	$\mu\text{A}$	IN1=IN2=IN3=0V *2
Input-side circuit current 2	$I_{DD2}$	-	25	100	$\mu\text{A}$	IN1=IN2=IN3=25kHz *2, Duty=50%
High level output voltage	$V_{OUTHX}^{*1}$	VCC-2.0	VCC-1.0	VCC-0.4	V	$I_{OUTHX} = -100\text{mA}^{*1}$
Low level output voltage	$V_{OUTLX}^{*1}$	0.15	0.4	1.0	V	$I_{OUTLX} = 100\text{mA}^{*1}$
Output delay time H 1	$t_{PLHX1}^{*1}$	170	250	330	ns	$V_{DD} = 5.0\text{V}$
Output delay time L 1	$t_{PHLX1}^{*1}$	185	265	345	ns	$V_{DD} = 5.0\text{V}$
Delay matching 1, $t_{PLHX1} - t_{PHLX1}^{*1}$	$\Delta t_{PLHX1-PHLX1}^{*1}$	-30	-15	20	ns	$V_{DD} = 5.0\text{V}$
Output delay time H 2	$t_{PLHX2}^{*1}$	170	250	330	ns	$V_{DD} = 3.3\text{V}$
Output delay time L 2	$t_{PHLX2}^{*1}$	220	300	380	ns	$V_{DD} = 3.3\text{V}$
Delay matching 2, $t_{PLHX2} - t_{PHLX2}^{*1}$	$\Delta t_{PLHX2-PHLX2}^{*1}$	-80	-50	10	ns	$V_{DD} = 3.3\text{V}$
Delay matching, $t_{PLHX} - t_{PHLY}^{*1}$	$\Delta t_{PLH}$	-20	0	20	ns	
Delay matching, $t_{PHLX} - t_{PHLY}^{*1}$	$\Delta t_{PHL}$	-20	0	20	ns	

\*1 BD6562FV-LB : X=1,2 Y=1,2  
BD6563FV-LB : X=1,2,3 Y=1,2,3

\*2 BD6562FV-LB : There is not IN3.

● Typical Performance Curves

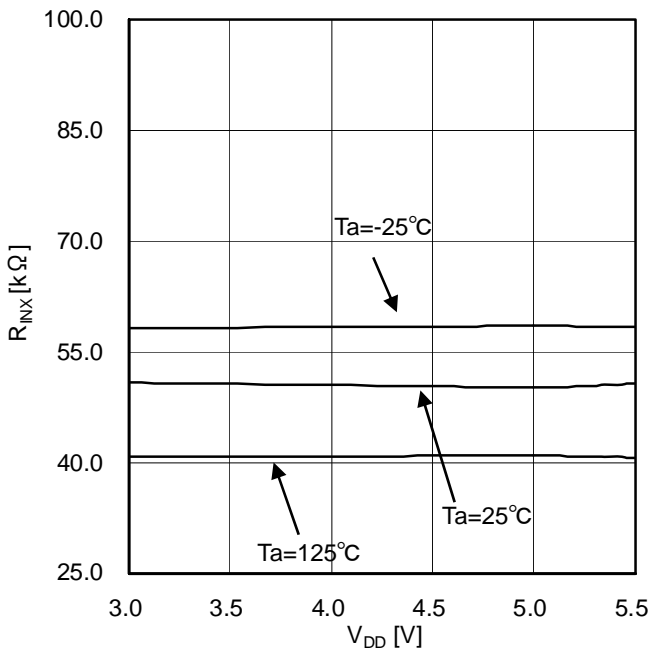

Figure 4. INX<sup>\*1</sup> pull-down resistance

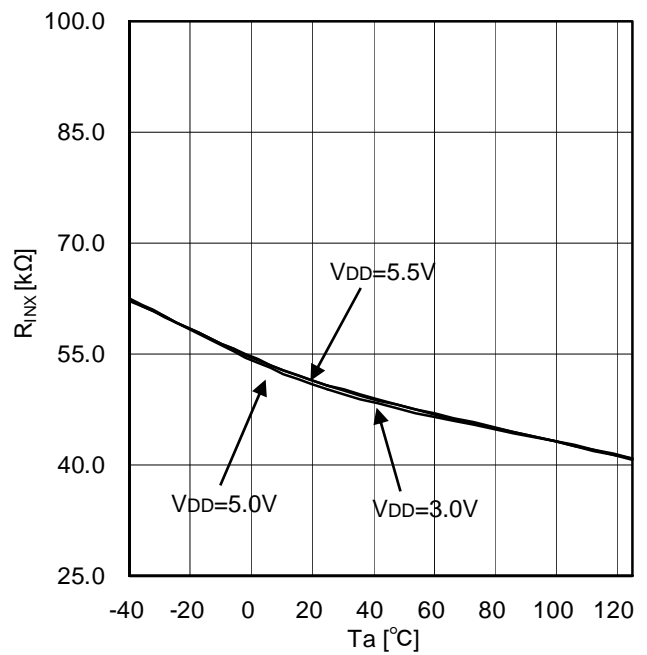

Figure 5. INX<sup>\*1</sup> pull-down resistance

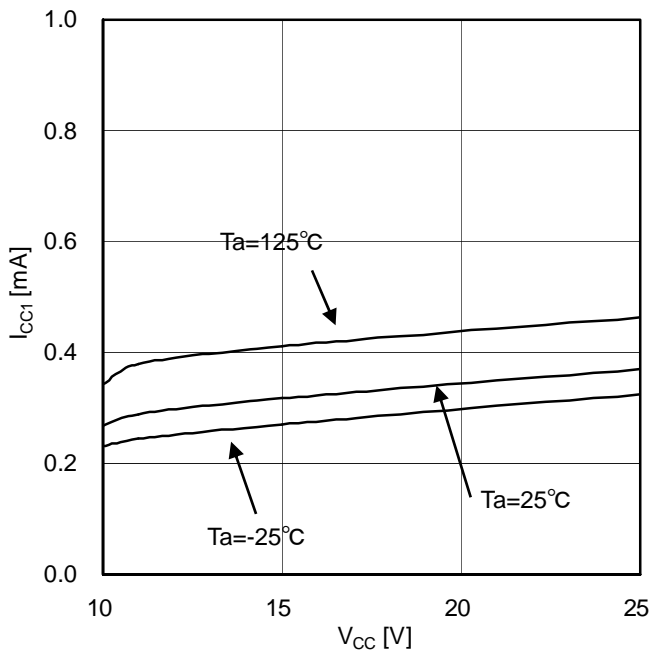

Figure 6. Output-side circuit current (at IN1=IN2=IN3=L<sup>\*2</sup>)

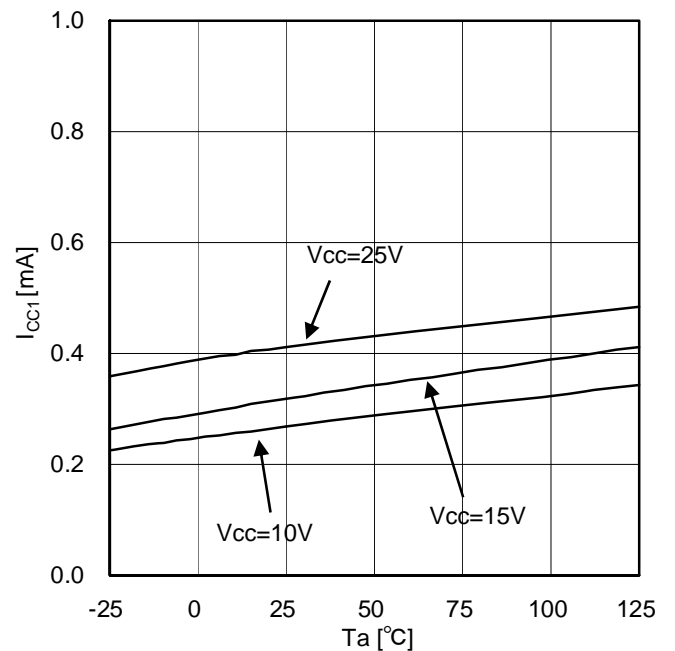

Figure 7. Output-side circuit current (at IN1=IN2=IN3=L<sup>\*2</sup>)

\*1 BD6562FV-LB : X=1,2  
 BD6563FV-LB : X=1,2,3  
 \*2 BD6562FV-LB : There is not IN3.

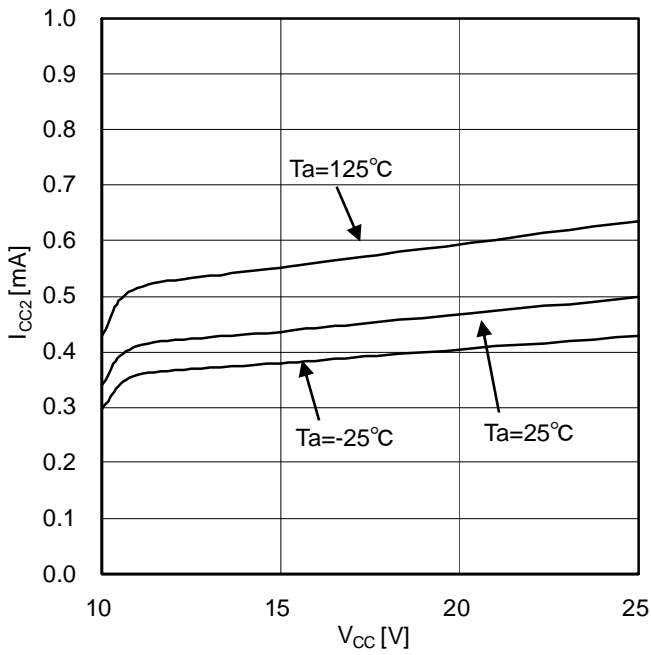

Figure 8. Output-side circuit current (at IN1=IN2=IN3=25kHz<sup>\*1</sup> and Duty=50%)

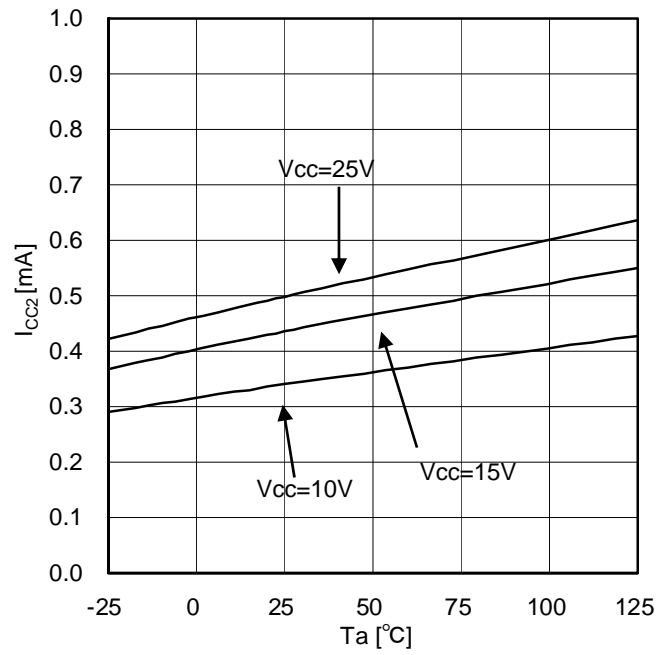

Figure 9. Output-side circuit current (at IN1=IN2=IN3=25kHz<sup>\*1</sup> and Duty=50%)

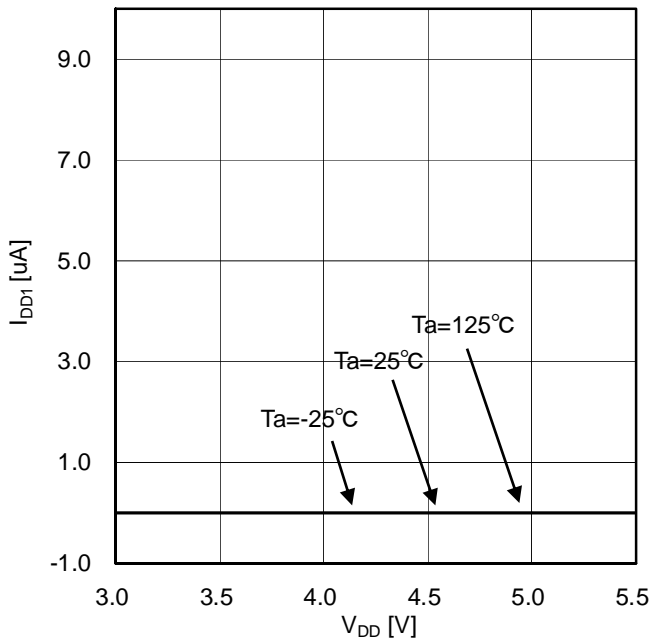

Figure 10. Input-side circuit current (at IN1=IN2=IN3=L<sup>\*1</sup>)

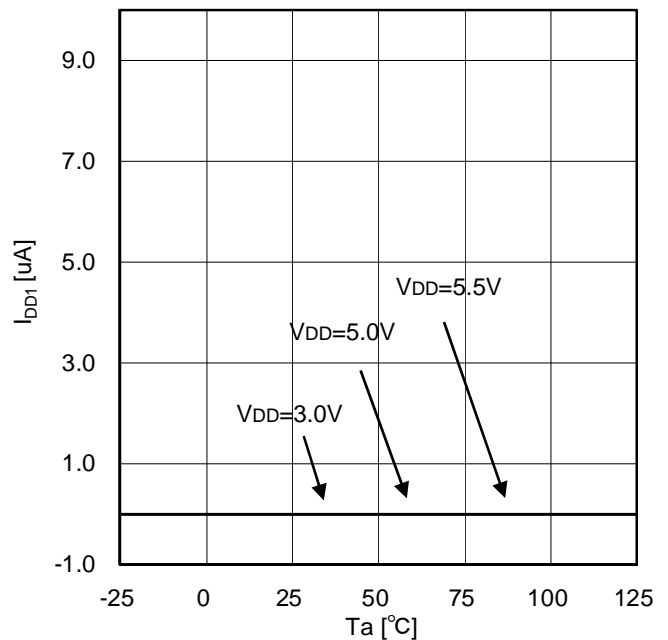

Figure 11. Input-side circuit current (at IN1=IN2=IN3=L<sup>\*1</sup>)

\*1 BD6562FV-LB : There is not IN3.

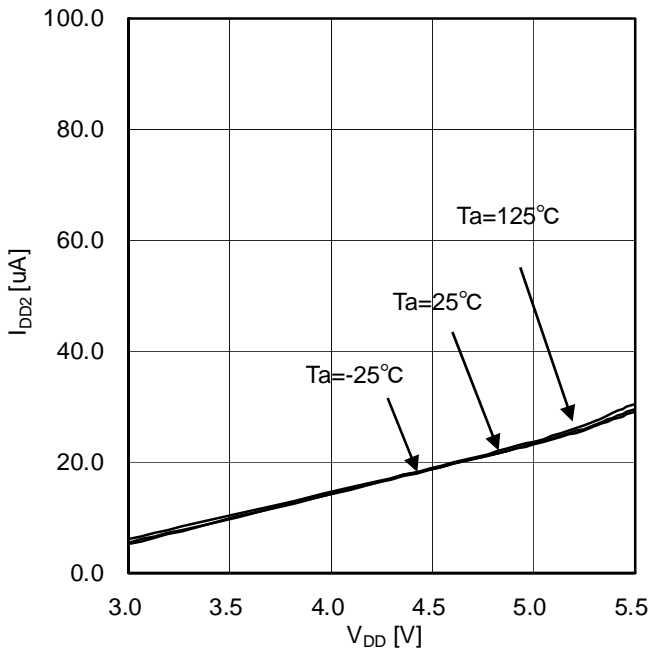

Figure 12. Input-side circuit current (at  $IN1=IN2=IN3=25kHz^{-1}$  and Duty=50%)

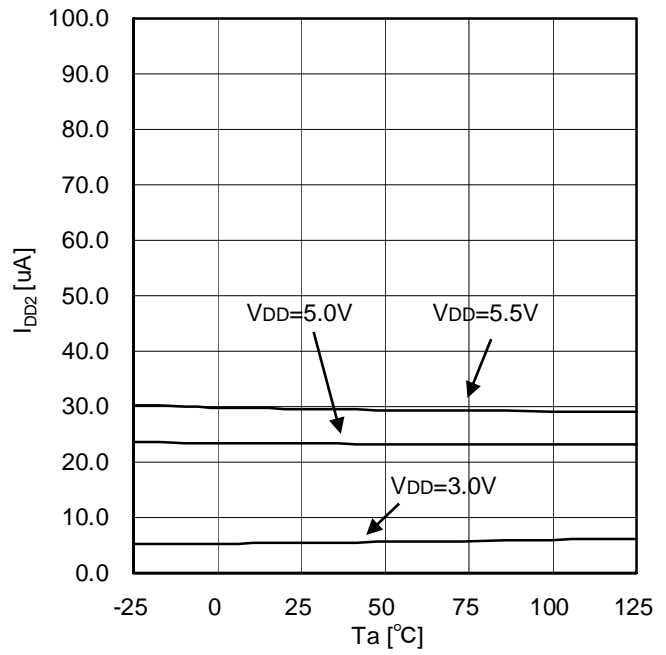

Figure 13. Input-side circuit current (at  $IN1=IN2=IN3=25kHz^{-1}$  and Duty=50%)

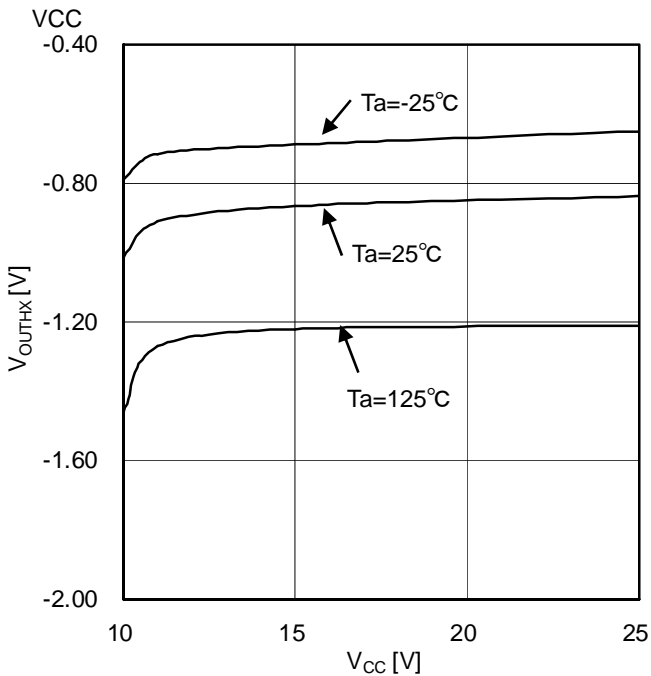

Figure 14. High level output voltage

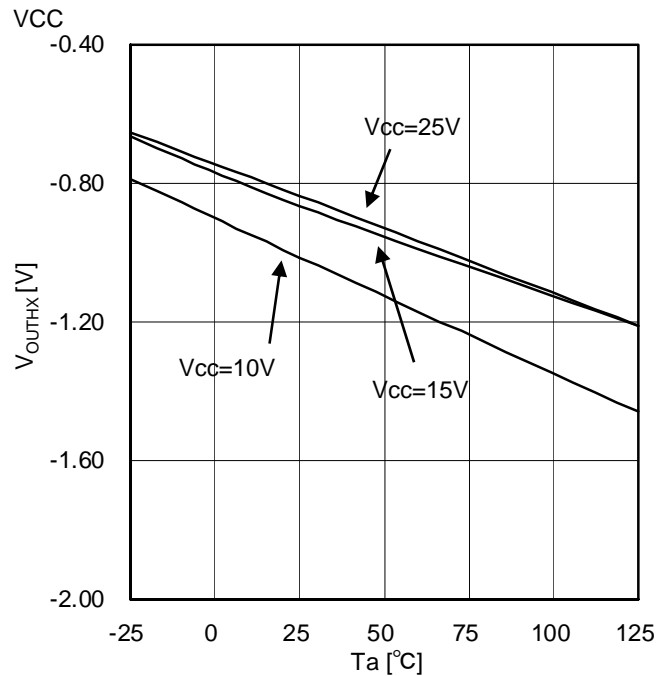

Figure 15. High level output voltage

\*1 BD6562FV-LB : There is not IN3.



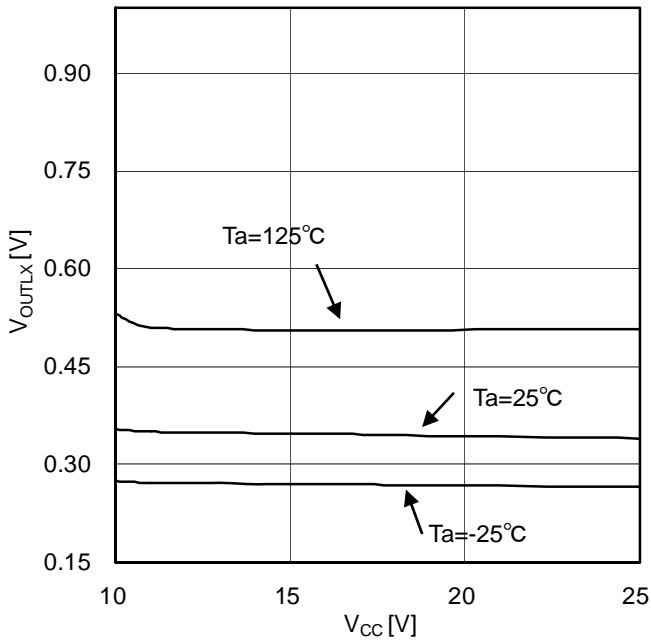

Figure 16. Low level output voltage

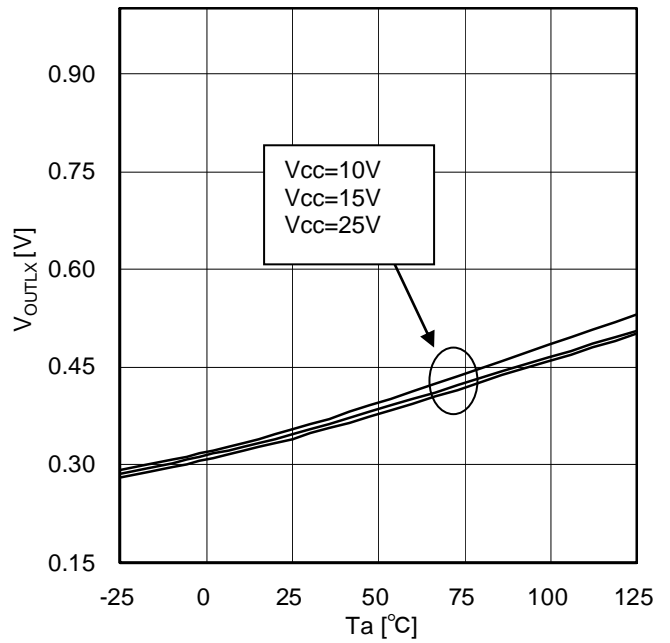

Figure 17. Low level output voltage

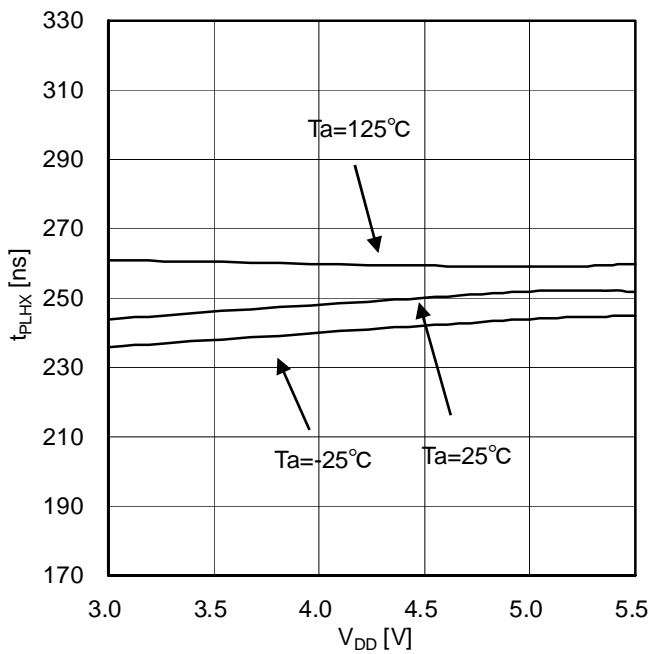

Figure 18. Output delay time H

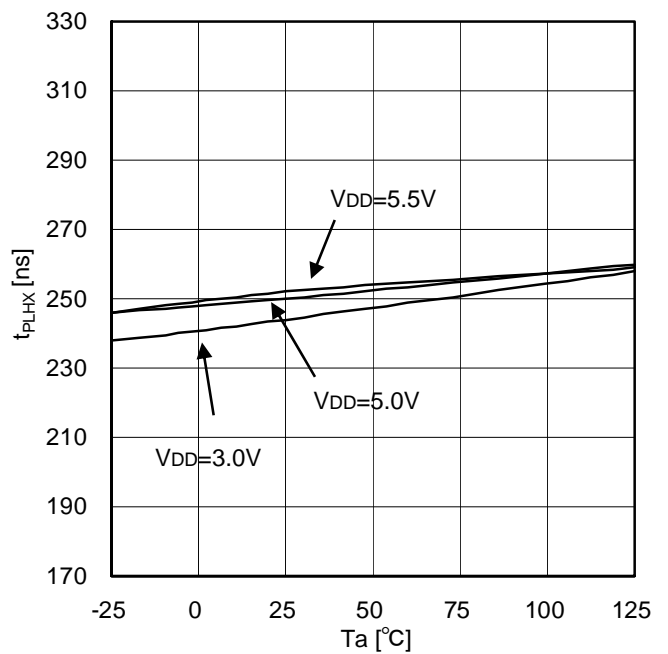

Figure 19. Output delay time H

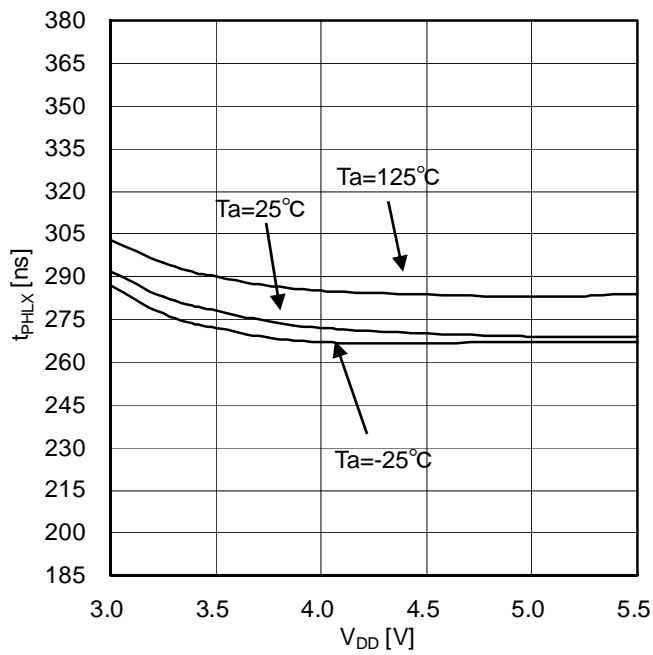

Figure 20. Output delay time L

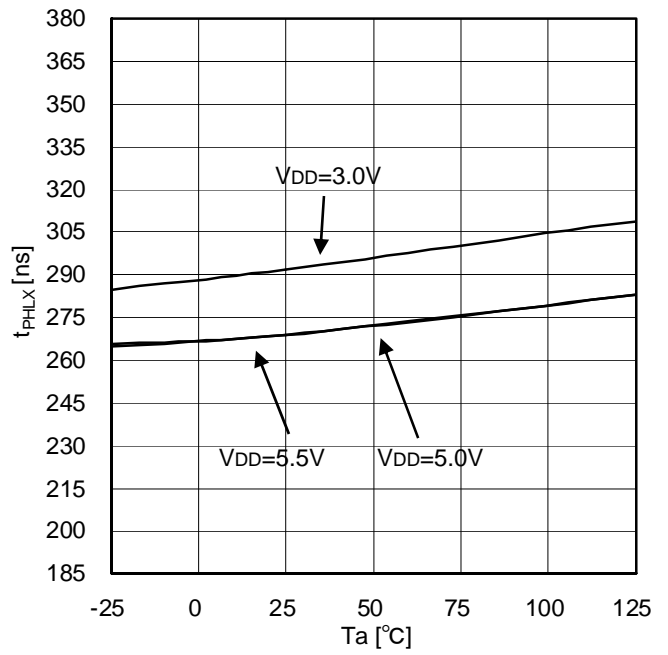

Figure 21. Output delay time L

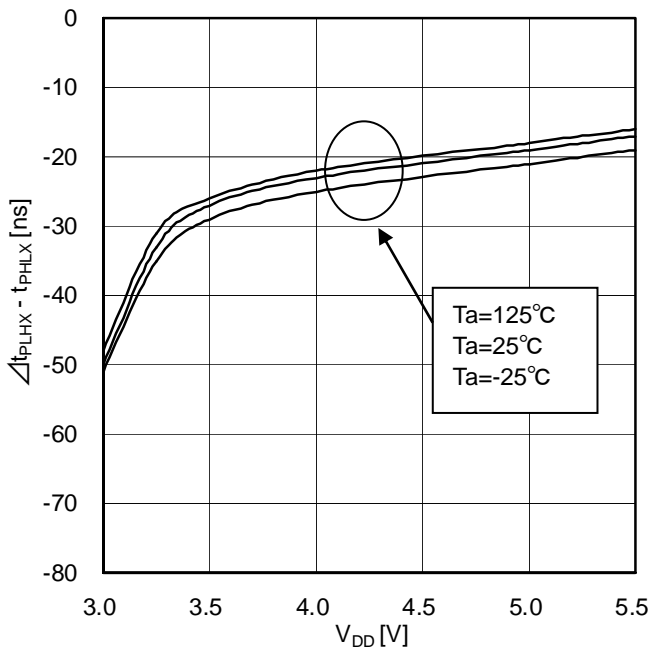

Figure 22. Delay matching, OUT\_HX and OUT\_LX \*\*

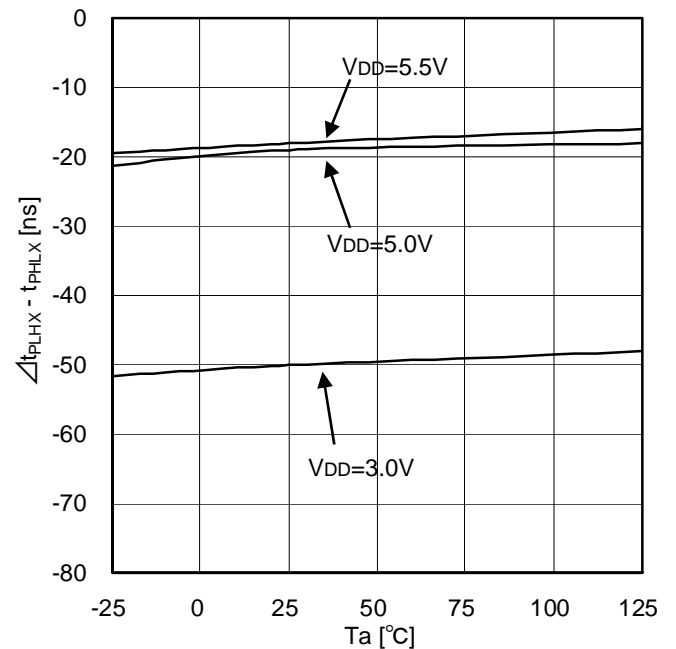

Figure 23. Delay matching, OUT\_HX and OUT\_LX \*\*

\*\* BD6562FV-LB : X=1,2  
BD6563FV-LB : X=1,2,3

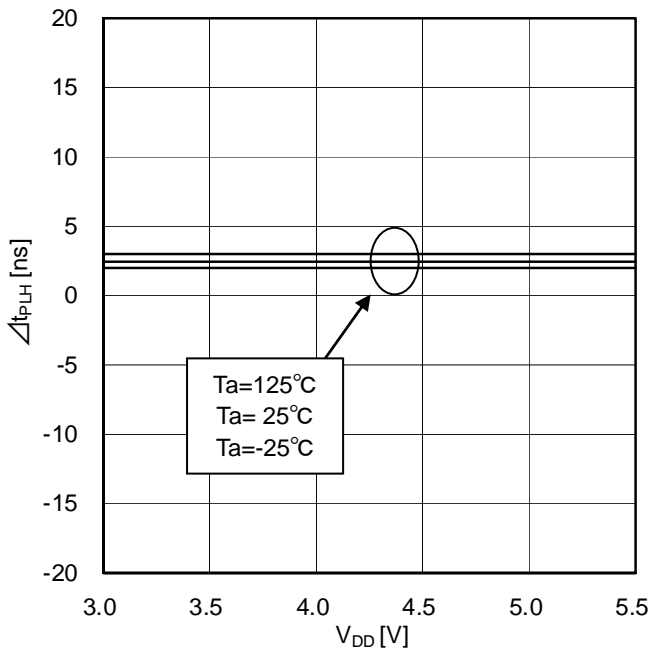

Figure 24. Delay matching, OUT\_H1, OUT\_H2, OUT\_H3 <sup>\*1</sup>

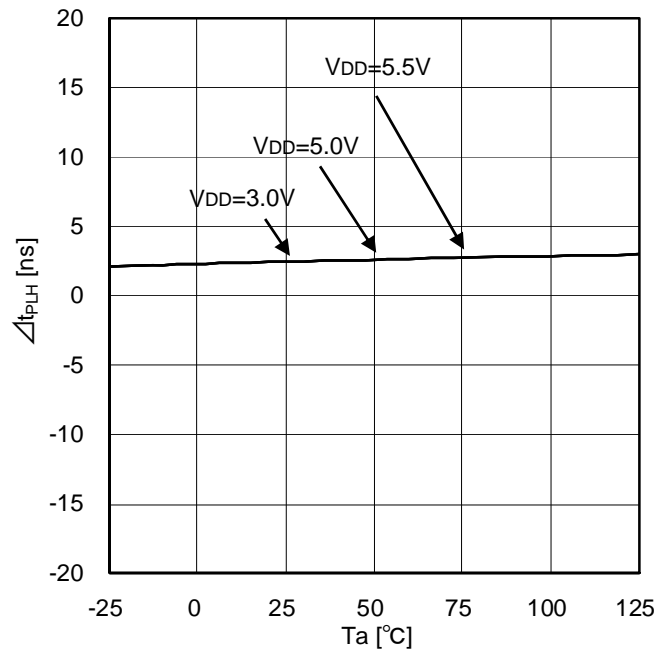

Figure 25. Delay matching, OUT\_H1, OUT\_H2, OUT\_H3 <sup>\*1</sup>

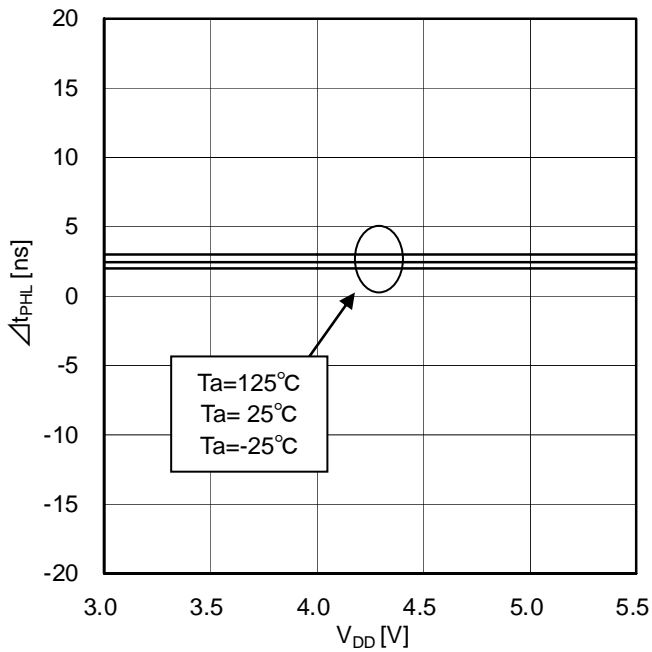

Figure 26. Delay matching, OUT\_L1, OUT\_L2, OUT\_L3 <sup>\*1</sup>

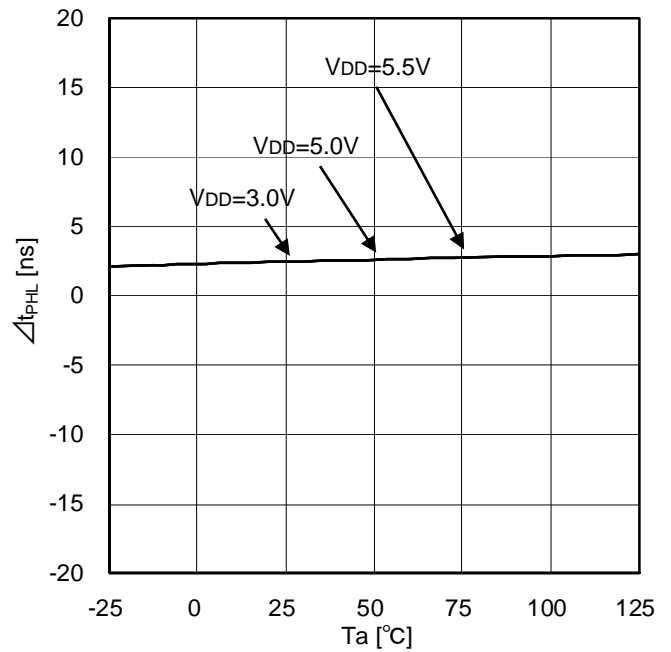
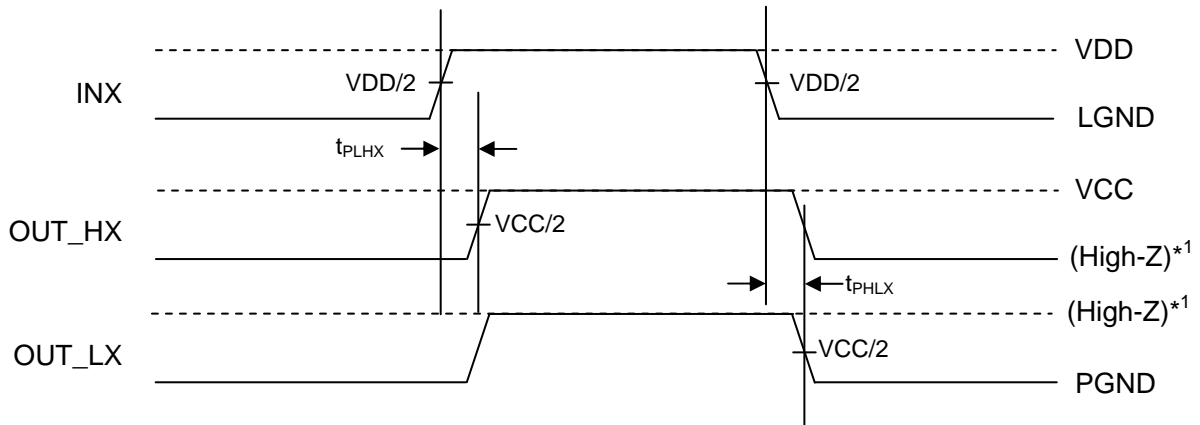

Figure 27. Delay matching, OUT\_L1, OUT\_L2, OUT\_L3 <sup>\*1</sup>

\*1 BD6562FV-LB : There are not OUT\_H3 and OUT\_L3

●Timing Chart



\*1 Under condition that OUT\_HX and OUT\_LX are shorted.

Figure 28. Timing Chart

●Power Dissipation

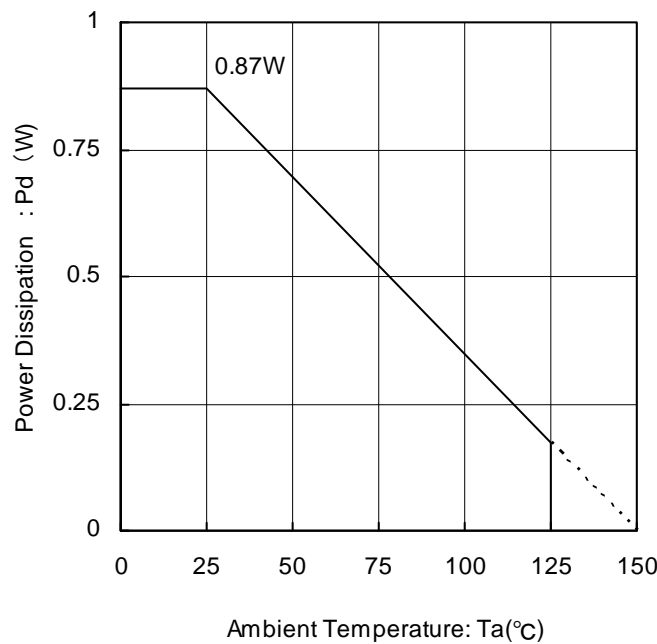

Figure 29. SSOP-B16 Derating Curve

Please confirm that the IC's chip temperature T<sub>j</sub> is not over 150°C, while considering the IC's power consumption (W), package power (P<sub>d</sub>) and ambient temperature (T<sub>a</sub>). When T<sub>j</sub>=150°C is exceeded the functions as a semiconductor do not operate and some problems (ex. Abnormal operation of various parasitic elements and increasing of leak current) occur. Constant use under these circumstances leads to deterioration and eventually IC may destruct. T<sub>jmax</sub>=150°C must be strictly obeyed under all circumstances.

● I/O equivalence circuits

Pin No.	Name	I/O equivalence circuits
	Function	
4, 5, 6	IN1, IN2, IN3 *1	
	Control input X pin	
9, 12, 15	OUT_L1, OUT_L2, OUT_L3 *1	
	Low-side output X pin	
10, 13, 16	OUT_H1, OUT_H2, OUT_H3 *1	
	High-side output X pin	

\*1 BD6562FV-LB : There are not IN3, OUT\_L3 and OUT\_H3.

●Operational Notes

- (1) Absolute maximum ratings  
An excess in the absolute maximum ratings, such as supply voltage, temperature range of operating conditions, etc., can break down the devices, thus making impossible to identify breaking mode, such as a short circuit or an open circuit. If any over rated values will expect to exceed the absolute maximum ratings, consider adding circuit protection devices, such as fuses.
- (2) Connecting the power supply connector backward  
Connecting of the power supply in reverse polarity can damage IC. Take precautions when connecting the power supply lines. An external direction diode can be added.
- (3) Power supply Lines  
Design PCB layout pattern to provide low impedance GND and supply lines. To obtain a low noise ground and supply line, separate the ground section and supply lines of the digital and analog blocks. Furthermore, for all power supply terminals to ICs, connect a capacitor between the power supply and the GND terminal. When applying electrolytic capacitors in the circuit, not that capacitance characteristic values are reduced at low temperatures.
- (4) GND Potential  
The potential of LGND pin and PGND pin must be minimum potential in all operating conditions.
- (5) Thermal design  
Use a thermal design that allows for a sufficient margin in light of the power dissipation (Pd) in actual operating conditions.
- (6) Inter-pin shorts and mounting errors  
When attaching to a printed circuit board, pay close attention to the direction of the IC and displacement. Improper attachment may lead to destruction of the IC. There is also possibility of destruction from short circuits which can be caused by foreign matter entering between outputs or an output and the power supply or GND.
- (7) Operation in a strong electric field  
Use caution when using the IC in the presence of a strong electromagnetic field as doing so may cause the IC to malfunction.
- (8) Inspection of the application board  
During inspection of the application board, if a capacitor is connected to a pin with low impedance there is a possibility that it could cause stress to the IC, therefore an electrical discharge should be performed after each process. Also, as a measure again electrostatic discharge, it should be earthed during the assembly process and special care should be taken during transport or storage. Furthermore, when connecting to the jig during the inspection process, the power supply should first be turned off and then removed before the inspection.

(9) Input terminal of IC

Between each element there is a P+ isolation for element partition and a P substrate. This P layer and each element's N layer make up the P-N junction, and various parasitic elements are made up.

For example, when the resistance and transistor are connected to the terminal as shown in figure 65,

○When  $GND > (\text{Terminal A})$  at the resistance and  $GND > (\text{Terminal B})$  at the transistor (NPN), the P-N junction operates as a parasitic diode.

○Also, when  $GND > (\text{Terminal B})$  at the transistor (NPN), The parasitic NPN transistor operates with the N layers of other elements close to the aforementioned parasitic diode.

Because of the IC's structure, the creation of parasitic elements is inevitable from the electrical potential relationship. The operation of parasitic elements causes interference in circuit operation, and can lead to malfunction and destruction. Therefore, be careful not to use it in a way which causes the parasitic elements to operate, such as by applying voltage that is lower than the GND (P substrate) to the input terminal.

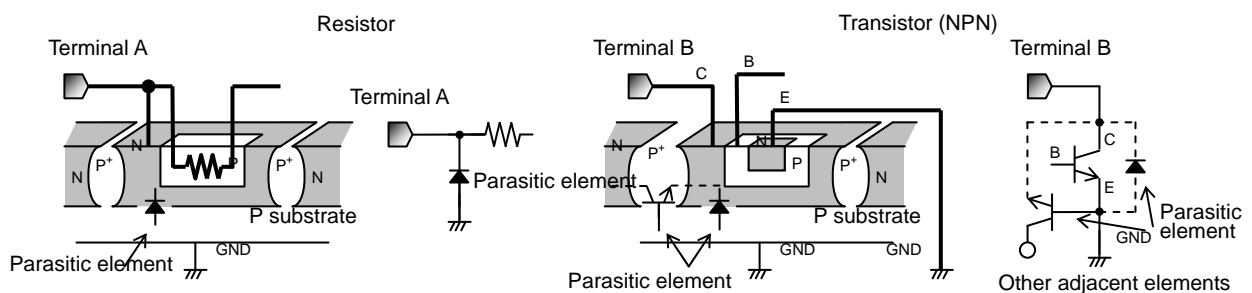

Figure 30. Pattern Diagram of Parasitic Element

(10) Ground Wiring Patterns

When using both small signal and large current GND patterns, it is recommended to isolate the two ground patterns, placing a single ground point at the application's reference point so that the pattern wiring resistance and voltage variations caused by large currents do not cause variations in the small signal ground voltage. Be careful not to change the GND wiring pattern potential of any external components, either.

The Japanese version of this document is formal specification. A customer may use this translation version only for a reference to help reading the formal version.

If there are any differences in translation version of this document formal version takes priority

●Ordering Information

B D 6 5 6 2 F V - LBE2

Part Number

Package  
FV : SSOP-B16

Product class  
LB for Industrial applications  
Packaging and forming specification  
E2: Embossed tape and reel

B D 6 5 6 3 F V - LBE2

Part Number

Package  
FV : SSOP-B16

Product class  
LB for Industrial applications  
Packaging and forming specification  
E2: Embossed tape and reel

●Physical Dimension Tape and Reel Information

SSOP-B16

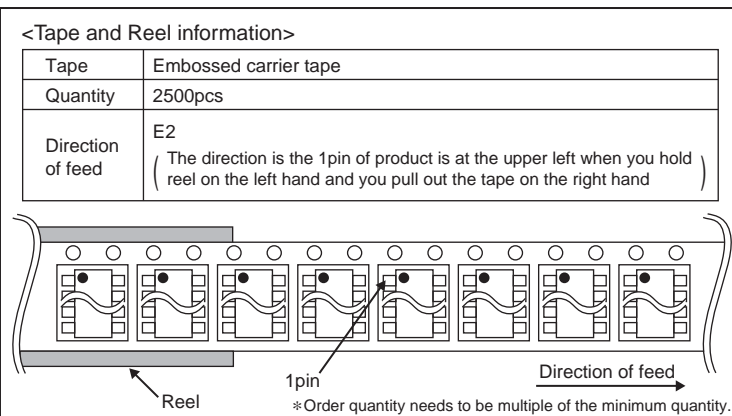
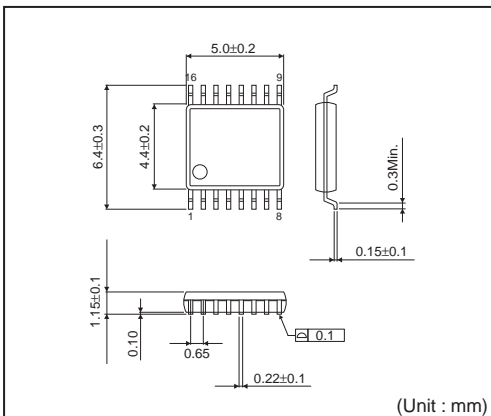

●Marking Diagram

BD6562FV-LB

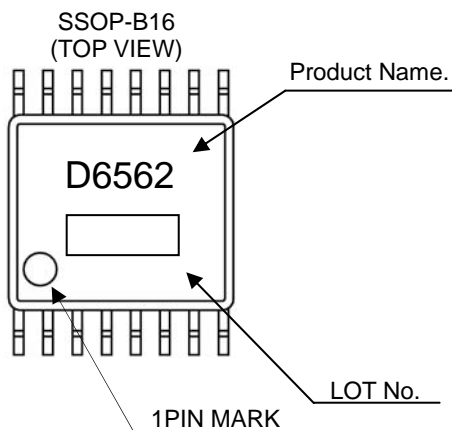

BD6563FV-LB

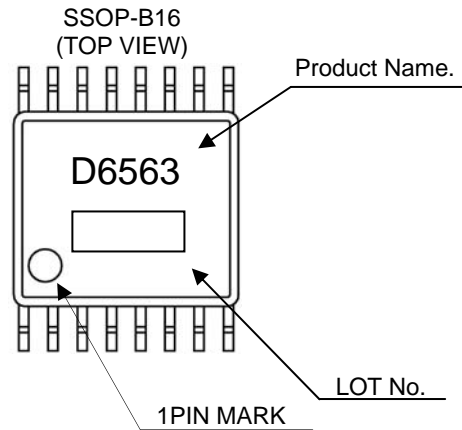

## ●Revision History

Date	Revision	Changes
20.JUN.2012	001	New Release
13.JUL.2012	002	Page 1 : Change Key Specifications 'Output peak current' Page 4 : Change Absolute Maximum Ratings 'OUT_HX pin output current' Page 4 : Change Absolute Maximum Ratings 'OUT_LX pin output current'
25.MAR.2013	003	Add BD6562FV
01.AUG.2013	004	Page 5 : Change Electrical Characteristics 'Delay matching 1" Page 5 : Change Electrical Characteristics 'Delay matching 2"
10.MAR.2014	005	Page 1 : Change "Long term operation and supply" ⇒ "Long Time Support" Page 15 : Add Ordering Information " Product class LB for Industrial applications"



# Notice

## Precaution on using ROHM Products

1. If you intend to use our Products in devices requiring extremely high reliability (such as medical equipment <sup>(Note 1)</sup>, aircraft/spacecraft, nuclear power controllers, etc.) and whose malfunction or failure may cause loss of human life, bodily injury or serious damage to property ("Specific Applications"), please consult with the ROHM sales representative in advance. Unless otherwise agreed in writing by ROHM in advance, ROHM shall not be in any way responsible or liable for any damages, expenses or losses incurred by you or third parties arising from the use of any ROHM's Products for Specific Applications.

(Note1) Medical Equipment Classification of the Specific Applications

JAPAN	USA	EU	CHINA
CLASS III	CLASS III	CLASS II b	CLASS III
CLASS IV		CLASS III	

2. ROHM designs and manufactures its Products subject to strict quality control system. However, semiconductor products can fail or malfunction at a certain rate. Please be sure to implement, at your own responsibilities, adequate safety measures including but not limited to fail-safe design against the physical injury, damage to any property, which a failure or malfunction of our Products may cause. The following are examples of safety measures:
  - [a] Installation of protection circuits or other protective devices to improve system safety
  - [b] Installation of redundant circuits to reduce the impact of single or multiple circuit failure
3. Our Products are not designed under any special or extraordinary environments or conditions, as exemplified below. Accordingly, ROHM shall not be in any way responsible or liable for any damages, expenses or losses arising from the use of any ROHM's Products under any special or extraordinary environments or conditions. If you intend to use our Products under any special or extraordinary environments or conditions (as exemplified below), your independent verification and confirmation of product performance, reliability, etc, prior to use, must be necessary:
  - [a] Use of our Products in any types of liquid, including water, oils, chemicals, and organic solvents
  - [b] Use of our Products outdoors or in places where the Products are exposed to direct sunlight or dust
  - [c] Use of our Products in places where the Products are exposed to sea wind or corrosive gases, including Cl<sub>2</sub>, H<sub>2</sub>S, NH<sub>3</sub>, SO<sub>2</sub>, and NO<sub>2</sub>
  - [d] Use of our Products in places where the Products are exposed to static electricity or electromagnetic waves
  - [e] Use of our Products in proximity to heat-producing components, plastic cords, or other flammable items
  - [f] Sealing or coating our Products with resin or other coating materials
  - [g] Use of our Products without cleaning residue of flux (even if you use no-clean type fluxes, cleaning residue of flux is recommended); or Washing our Products by using water or water-soluble cleaning agents for cleaning residue after soldering
  - [h] Use of the Products in places subject to dew condensation
4. The Products are not subject to radiation-proof design.
5. Please verify and confirm characteristics of the final or mounted products in using the Products.
6. In particular, if a transient load (a large amount of load applied in a short period of time, such as pulse. is applied, confirmation of performance characteristics after on-board mounting is strongly recommended. Avoid applying power exceeding normal rated power; exceeding the power rating under steady-state loading condition may negatively affect product performance and reliability.
7. De-rate Power Dissipation (Pd) depending on Ambient temperature (Ta). When used in sealed area, confirm the actual ambient temperature.
8. Confirm that operation temperature is within the specified range described in the product specification.
9. ROHM shall not be in any way responsible or liable for failure induced under deviant condition from what is defined in this document.

## Precaution for Mounting / Circuit board design

1. When a highly active halogenous (chlorine, bromine, etc.) flux is used, the residue of flux may negatively affect product performance and reliability.
2. In principle, the reflow soldering method must be used; if flow soldering method is preferred, please consult with the ROHM representative in advance.

For details, please refer to ROHM Mounting specification

**Precautions Regarding Application Examples and External Circuits**

1. If change is made to the constant of an external circuit, please allow a sufficient margin considering variations of the characteristics of the Products and external components, including transient characteristics, as well as static characteristics.
2. You agree that application notes, reference designs, and associated data and information contained in this document are presented only as guidance for Products use. Therefore, in case you use such information, you are solely responsible for it and you must exercise your own independent verification and judgment in the use of such information contained in this document. ROHM shall not be in any way responsible or liable for any damages, expenses or losses incurred by you or third parties arising from the use of such information.

**Precaution for Electrostatic**

This Product is electrostatic sensitive product, which may be damaged due to electrostatic discharge. Please take proper caution in your manufacturing process and storage so that voltage exceeding the Products maximum rating will not be applied to Products. Please take special care under dry condition (e.g. Grounding of human body / equipment / solder iron, isolation from charged objects, setting of Ionizer, friction prevention and temperature / humidity control).

**Precaution for Storage / Transportation**

1. Product performance and soldered connections may deteriorate if the Products are stored in the places where:
  - [a] the Products are exposed to sea winds or corrosive gases, including Cl<sub>2</sub>, H<sub>2</sub>S, NH<sub>3</sub>, SO<sub>2</sub>, and NO<sub>2</sub>
  - [b] the temperature or humidity exceeds those recommended by ROHM
  - [c] the Products are exposed to direct sunshine or condensation
  - [d] the Products are exposed to high Electrostatic
2. Even under ROHM recommended storage condition, solderability of products out of recommended storage time period may be degraded. It is strongly recommended to confirm solderability before using Products of which storage time is exceeding the recommended storage time period.
3. Store / transport cartons in the correct direction, which is indicated on a carton with a symbol. Otherwise bent leads may occur due to excessive stress applied when dropping of a carton.
4. Use Products within the specified time after opening a humidity barrier bag. Baking is required before using Products of which storage time is exceeding the recommended storage time period.

**Precaution for Product Label**

QR code printed on ROHM Products label is for ROHM's internal use only.

**Precaution for Disposition**

When disposing Products please dispose them properly using an authorized industry waste company.

**Precaution for Foreign Exchange and Foreign Trade act**

Since our Products might fall under controlled goods prescribed by the applicable foreign exchange and foreign trade act, please consult with ROHM representative in case of export.

**Precaution Regarding Intellectual Property Rights**

1. All information and data including but not limited to application example contained in this document is for reference only. ROHM does not warrant that foregoing information or data will not infringe any intellectual property rights or any other rights of any third party regarding such information or data. ROHM shall not be in any way responsible or liable for infringement of any intellectual property rights or other damages arising from use of such information or data.:
2. No license, expressly or implied, is granted hereby under any intellectual property rights or other rights of ROHM or any third parties with respect to the information contained in this document.

**Other Precaution**

1. This document may not be reprinted or reproduced, in whole or in part, without prior written consent of ROHM.
2. The Products may not be disassembled, converted, modified, reproduced or otherwise changed without prior written consent of ROHM.
3. In no event shall you use in any way whatsoever the Products and the related technical information contained in the Products or this document for any military purposes, including but not limited to, the development of mass-destruction weapons.
4. The proper names of companies or products described in this document are trademarks or registered trademarks of ROHM, its affiliated companies or third parties.

**General Precaution**

1. Before you use our Products, you are requested to carefully read this document and fully understand its contents. ROHM shall not be in any way responsible or liable for failure, malfunction or accident arising from the use of any ROHM's Products against warning, caution or note contained in this document.
2. All information contained in this document is current as of the issuing date and subject to change without any prior notice. Before purchasing or using ROHM's Products, please confirm the latest information with a ROHM sales representative.
3. The information contained in this document is provided on an "as is" basis and ROHM does not warrant that all information contained in this document is accurate and/or error-free. ROHM shall not be in any way responsible or liable for any damages, expenses or losses incurred by you or third parties resulting from inaccuracy or errors of or concerning such information.

# Mouser Electronics

Authorized Distributor

Click to View Pricing, Inventory, Delivery & Lifecycle Information:

[ROHM Semiconductor:](#)

[BD6563FV-LBE2](#)

Компания «Life Electronics» занимается поставками электронных компонентов импортного и отечественного производства от производителей и со складов крупных дистрибьюторов Европы, Америки и Азии.

С конца 2013 года компания активно расширяет линейку поставок компонентов по направлению коаксиальный кабель, кварцевые генераторы и конденсаторы (керамические, пленочные, электролитические), за счёт заключения дистрибьюторских договоров

Мы предлагаем:

- Конкуренеспособные цены и скидки постоянным клиентам.
- Специальные условия для постоянных клиентов.
- Подбор аналогов.
- Поставку компонентов в любых объемах, удовлетворяющих вашим потребностям.
- Приемлемые сроки поставки, возможна ускоренная поставка.
- Доставку товара в любую точку России и стран СНГ.
- Комплексную поставку.
- Работу по проектам и поставку образцов.
- Формирование склада под заказчика.
- Сертификаты соответствия на поставляемую продукцию (по желанию клиента).
- Тестирование поставляемой продукции.
- Поставку компонентов, требующих военную и космическую приемку.
- Входной контроль качества.
- Наличие сертификата ISO.

В составе нашей компании организован Конструкторский отдел, призванный помогать разработчикам, и инженерам.

Конструкторский отдел помогает осуществить:

- Регистрацию проекта у производителя компонентов.
- Техническую поддержку проекта.
- Защиту от снятия компонента с производства.
- Оценку стоимости проекта по компонентам.
- Изготовление тестовой платы монтаж и пусконаладочные работы.



Тел: +7 (812) 336 43 04 (многоканальный)  
Email: [org@lifeelectronics.ru](mailto:org@lifeelectronics.ru)