



## 1 Overview

### Application

- Suitable for resistive, inductive and capacitive loads
- Replaces electromechanical relays, fuses and discrete circuits
- Most suitable for inductive loads as well as loads with inrush currents

### Features

- Single channel device
- Very low power DMOS leakage current in OFF state
- 3.3 V and 5 V compatible logic inputs
- Electrostatic discharge protection (ESD)
- Adjustable switching speed
- Digital Feedback
- Green Product (RoHS compliant)
- AEC Qualified

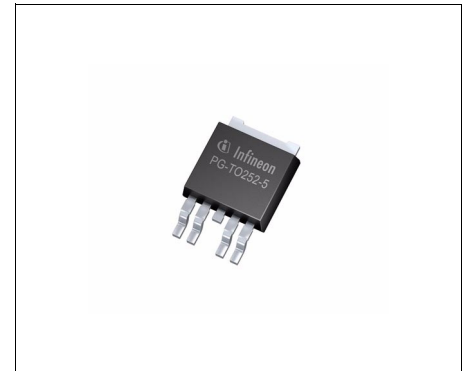

**PG-TO252-5**

### Description

The BTF3050TE is a 50 mΩ single channel Smart Low-Side Power Switch in a PG-TO252-5 package providing embedded protective functions. The power transistor is built by a N-channel vertical power MOSFET. The device is monolithically integrated. The BTF3050TE is automotive qualified and is optimized for 12V automotive and industrial applications.

**Table 1 Product Summary**

Operating voltage range	$V_{OUT}$	3 .. 28 V
Maximum load voltage	$V_{BAT(LD)}$	40 V
Operating supply voltage range	$V_{DD}$	3.0 .. 5.5 V
Maximum input voltage	$V_{IN}$	5.5 V
Maximum On-State resistance at $T_J = 150^{\circ}\text{C}$ , $V_{DD} = 5\text{V}$	$R_{DS(ON)}$	100 mΩ
Nominal load current	$I_{L(NOM)}$	3.0 A
Minimum current limitation trigger level	$I_{L(LIM\_TRIGGER)}$	30 A
Maximum OFF state load current at $T_J \leq 85^{\circ}\text{C}$	$I_{L(OFF)}$	2 μA
Maximum stand-by supply current at $T_J = 25^{\circ}\text{C}$	$I_{DD(OFF)}$	6 μA

Type	Package	Marking
BTF3050TE	PG-TO252-5	

**Diagnostic Functions**

- Short circuit to battery
- Over temperature
- Stable latching diagnostic signal

**Protection Functions**

- Over temperature shutdown with auto-restart
- Active clamp over voltage protection of the output
- Current limitation
- Enhanced short circuit protection

**Detailed Description**

The device is able to switch all kind of resistive, inductive and capacitive loads, limited by clamping energy ( $E_{AS}$ ) and maximum current capabilities.

The BTF3050TE offers dedicated ESD protection on the IN, VDD and SRP pins which refers to the Ground pin, as well as an over voltage clamping of the output to Source/GND.

The over voltage protection gets activated during inductive turn off conditions or other over voltage events (e.g. load dump). The power MOSFET is limiting the drain-source voltage, if it rises above the  $V_{OUT(CLAMP)}$ .

The over temperature protection prevents the device from overheating due to overload and/or bad cooling conditions.

The BTF3050TE has a thermal-restart function. The device will turn on again, if input is still high, after the measured temperature has dropped below the thermal hysteresis.

## Table of Contents

<b>1</b>	<b>Overview</b>	<b>1</b>
<b>2</b>	<b>Block Diagram</b>	<b>5</b>
<b>3</b>	<b>Pin Configuration</b>	<b>6</b>
3.1	Pin Assignment BTF3050TE	6
3.2	Pin Definitions and Functions	6
3.3	Voltage and Current Definition	6
<b>4</b>	<b>General Product Characteristics</b>	<b>7</b>
4.1	Absolute Maximum Ratings	7
4.2	Functional Range	8
4.3	Thermal Resistance	9
4.3.1	PCB set up	9
4.3.2	Transient Thermal Impedance	10
<b>5</b>	<b>Power Stage</b>	<b>12</b>
5.1	Output On-state Resistance	12
5.2	Resistive Load Output Timing	12
5.3	Inductive Load	13
5.3.1	Output Clamping	13
5.3.2	Maximum Load Inductance	14
5.4	Reverse/Inverse Current Capability	14
5.5	Adjustable Switching Speed / Slew Rate	15
5.6	Characteristics	16
<b>6</b>	<b>Protection Functions</b>	<b>17</b>
6.1	Over Voltage Clamping on OUTput	17
6.2	Thermal Protection with Latched Fault Signal	17
6.3	Overcurrent Limitation / Short Circuit Behavior	18
6.4	Characteristics	20
<b>7</b>	<b>Diagnostics</b>	<b>21</b>
7.1	Functional Description of the SRP Pin	21
7.2	Characteristics	22
<b>8</b>	<b>Supply and Input Stage</b>	<b>23</b>
8.1	Supply Circuit	23
8.1.1	Undervoltage Shutdown	23
8.2	Input Circuit	23
8.3	Characteristics	24
<b>9</b>	<b>Electrical Characteristics</b>	<b>25</b>
9.1	Power Stage	25
9.2	Protection	26
9.3	Diagnostics	27
9.4	Supply and Input Stage	29
<b>10</b>	<b>Characterisation Results</b>	<b>30</b>
10.1	Power Stage	30
10.2	Dynamic characteristics:	32
10.3	Protection	39
10.4	Supply and Input Stage	42
<b>11</b>	<b>Application Information</b>	<b>45</b>



---

**Table of Contents**

11.1	Design and Layout Recommendations/Considerations .....	45
12	<b>Package Outlines BTF3050TE</b> .....	46
13	<b>Revision History</b> .....	47

## 2 Block Diagram

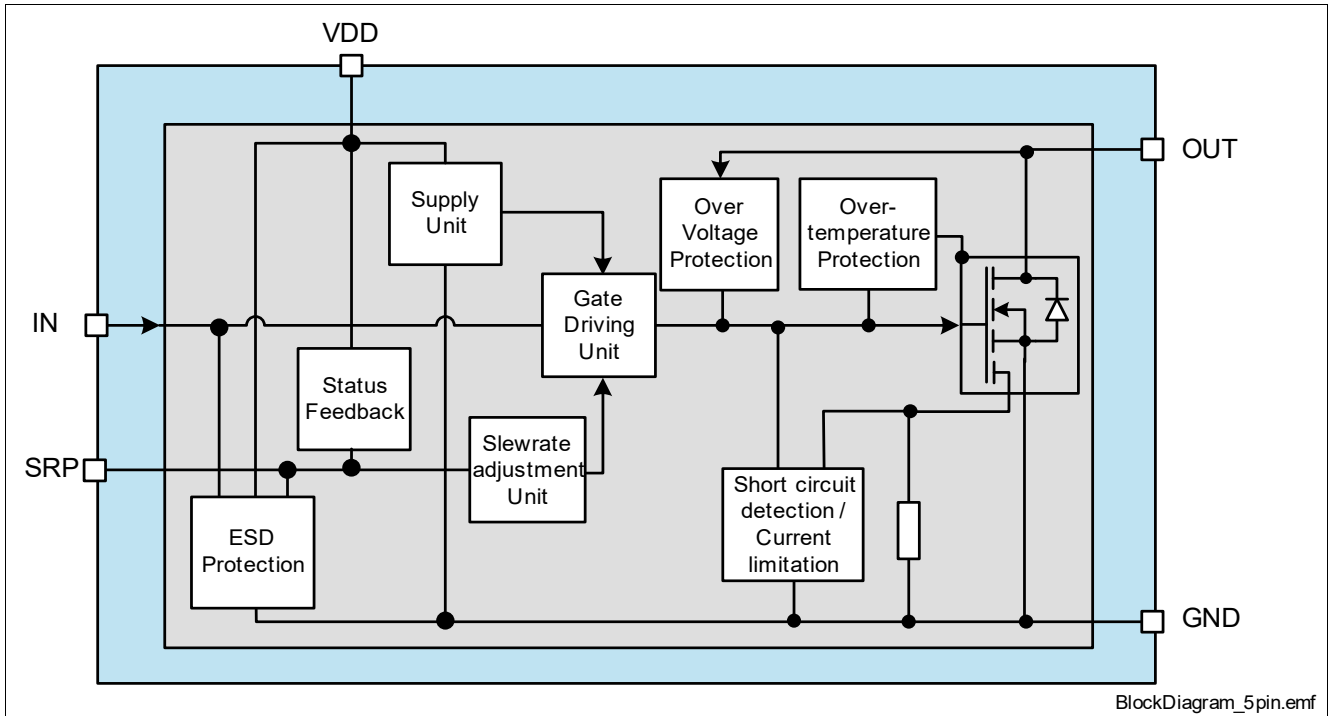

Figure 1 Block Diagram

### 3 Pin Configuration

#### 3.1 Pin Assignment BTF3050TE

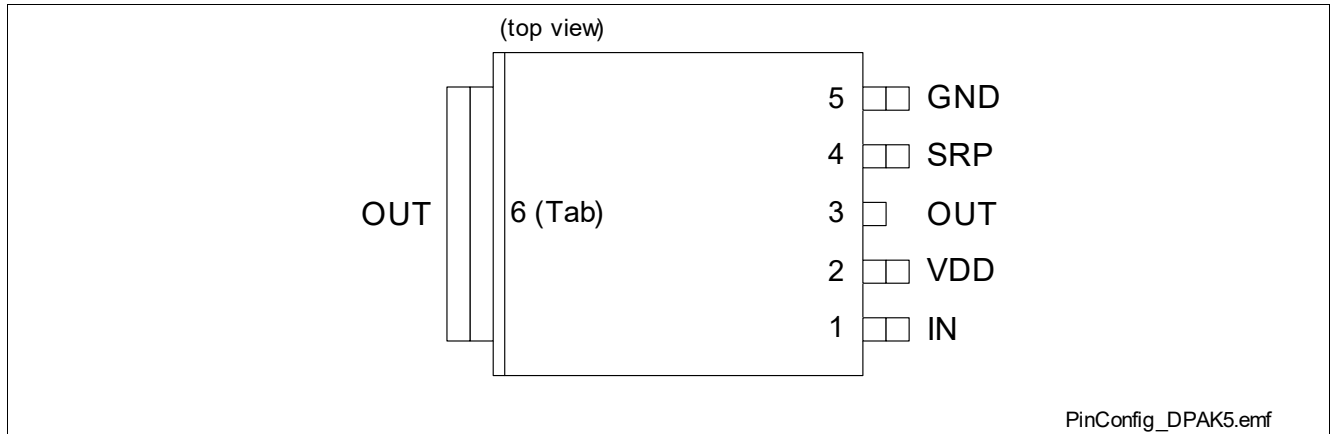

Figure 2 Pin Configuration PG-TO252-5

#### 3.2 Pin Definitions and Functions

Pin	Symbol	Function
1	IN	Input pin
2	VDD	5V supply pin
3,6	OUT	Drain, Load connection for power DMOS
4	SRP	Slew rate adjustment and digital status feedback
5	GND	Ground, Source of power DMOS

#### 3.3 Voltage and Current Definition

Figure 3 shows all external terms used in this data sheet, with associated convention for positive values.

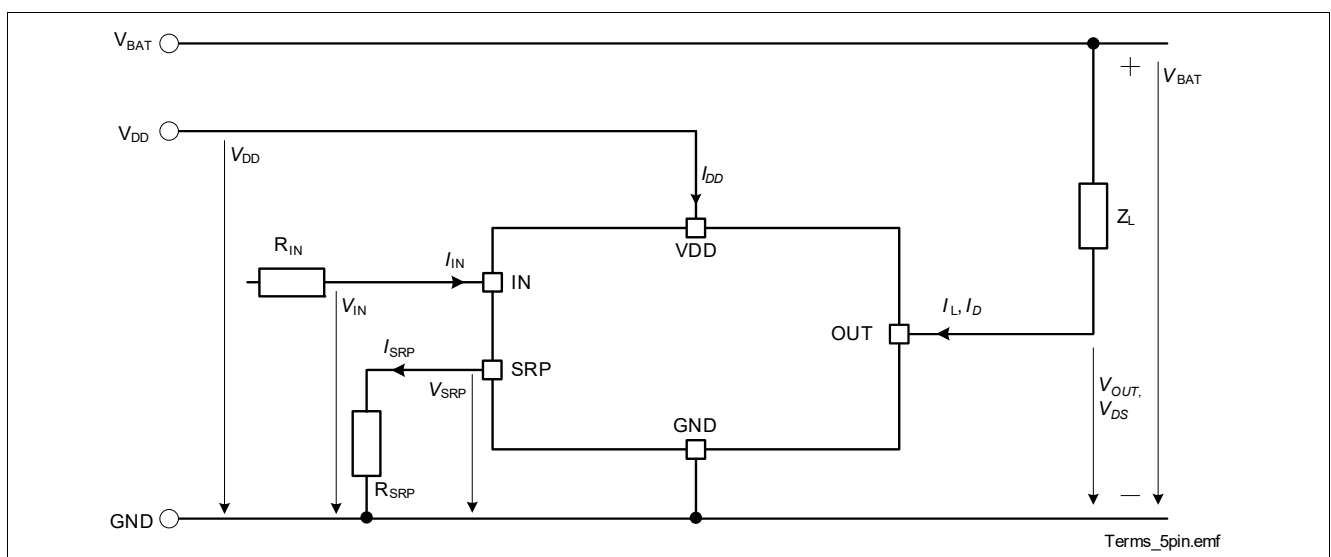

Figure 3 Naming Definition of electrical parameters

## 4 General Product Characteristics

### 4.1 Absolute Maximum Ratings

**Table 2 Absolute Maximum Ratings<sup>1)</sup>**

$T_J = -40\text{ °C}$  to  $+150\text{ °C}$ ; all voltages with respect to ground, positive current flowing into pin  
(unless otherwise specified)

Pos.	Parameter	Symbol	Limit Values		Unit	Note / Test Condition
			Min.	Max.		
<b>Voltages</b>						
4.1.1	Supply voltage	$V_{DD}$	-0.3	5.5	V	–
4.1.2	Output voltage	$V_{OUT}$	-0.3	40	V	internally clamped
4.1.3	Battery voltage for short circuit protection	$V_{BAT(SC)}$	–	28	V	<sup>1)</sup> $l = 0 \dots 5\text{m}$ $R_{SC} = 30\text{ m}\Omega + R_{CABLE}$ $R_{CABLE} = l * 16\text{ m}\Omega/\text{m}$ $L_{SC} = 5\text{ }\mu\text{H} + L_{CABLE}$ $L_{CABLE} = l * 1\text{ }\mu\text{H}/\text{m}$
4.1.4	Battery voltage for load dump protection ( $V_{BAT(LD)} = V_A + V_S$ with $V_A = 13.5\text{V}$ )	$V_{BAT(LD)}$	–	40	V	<sup>2)</sup> $R_I = 2\text{ }\Omega$ , $R_L = 4.5\text{ }\Omega$ , $t_D = 400\text{ ms}$ , suppressed pulse
<b>Input and SRP Pins</b>						
4.1.5	Input Voltage	$V_{IN}$	-0.3	5.5	V	–
4.1.6	SRP pin Voltage	$V_{SRP}$	-0.3	5.5	V	$V_{SRP} < V_{DD}$
<b>Power Stage</b>						
4.1.7	Load current	$ I_L $	–	$I_{L(LIM)_TRIGGER}$	A	$T_J < 150\text{ °C}$
<b>Energies</b>						
4.1.8	Unclamped single inductive energy single pulse	$E_{AS}$	–	120	mJ	$I_{L(0)} = I_{L(NOM)}$ $V_{BAT} = 13.5\text{ V}$ $T_{J(0)} = 150\text{ °C}$
4.1.9	Unclamped repetitive inductive energy pulse with 100k cycles	$E_{AR(100k)}$	–	80	mJ	$I_{L(0)} = 4.5\text{ A}$ $V_{BAT} = 13.5\text{ V}$ $T_{J(0)} = 105\text{ °C}$
<b>Temperatures</b>						
4.1.10	Operating temperature	$T_J$	-40	+150	°C	–
4.1.11	Storage temperature	$T_{STG}$	-55	+150	°C	–
<b>ESD Susceptibility</b>						
4.1.12	ESD susceptibility (all pins)	$V_{ESD}$	-2	2	kV	HBM <sup>3)</sup>
4.1.13	ESD susceptibility OUT pin vs. GND	$V_{ESD}$	-4	4	kV	HBM <sup>3)</sup>
4.1.14	ESD susceptibility	$V_{ESD}$	-750	750	V	CDM <sup>4)</sup>

1) Not subject to production test, specified by design.

- 2)  $V_{BAT(LD)}$  is setup without the DUT connected to the generator per ISO7637-1;  
 $R_i$  is the internal resistance of the load dump test pulse generator;  
 $t_D$  is the pulse duration time for load dump pulse (pulse 5) according ISO 7637-1, -2.
- 3) ESD susceptibility, HBM according to ANSI/ESDA/JEDEC JS-001 (1.5 kΩ, 100 pF)
- 4) ESD susceptibility, Charged Device Model "CDM" ESDA STM5.3.1 or ANSI/ESD S.5.3.1

*Note: Stresses above the ones listed here may cause permanent damage to the device. Exposure to absolute maximum rating conditions for extended periods may affect device reliability.*

*Note: Integrated protection functions are designed to prevent IC destruction under fault conditions described in the data sheet. Fault conditions are considered as "outside" normal operating range. Protection functions are not designed for continuous repetitive operation*

## 4.2 Functional Range

**Table 3 Functional Range<sup>1)</sup>**

Pos.	Parameter	Symbol	Limit Values			Unit	Note / Test Condition
			Min.	Typ.	Max.		
4.2.1	Supply Voltage Range for Normal Operation	$V_{DD(NOR)}$	3.0	5.0	5.5	V	–
4.2.2	Supply current continuous ON operation	$I_{DD}$	–	2.5	6	mA	–
4.2.3	Standby supply current (ambient)	$I_{DD(OFF)_25}$	–	1.5	6	μA	$T_J = 25\text{ °C}$
4.2.4	Maximum standby supply current (hot)	$I_{DD(OFF)_150}$	–	6	14	μA	$T_J = 150\text{ °C}$
4.2.5	Battery Voltage Range for Nominal Operation	$V_{BAT(NOR)}$	8	13.5	18	V	–
4.2.6	Extended Battery Voltage Range for Operation	$V_{BAT(EXT)}$	3	–	28	V	parameter deviations possible
4.2.7	SRP pin resistor for normal operation	$R_{SRP(NOR)}$	5	–	70	kΩ	–
4.2.8	SRP pin resistor for extended operation	$R_{SRP(EXT)}$	0	–	600	Ω	no latched fault available

1) Not subject to production test, specified by design.

*Note: Within the functional range the IC operates as described in the circuit description. The electrical characteristics are specified within the conditions given in the related electrical characteristics table.*



### 4.3 Thermal Resistance

Note: This thermal data was generated in accordance with JEDEC JESD51 standards.

For more information, go to [www.jedec.org](http://www.jedec.org).

**Table 4 Thermal resistance**

Pos.	Parameter	Symbol	Limit Values			Unit	Note / Test Condition
			Min.	Typ.	Max.		
4.3.1	Junction to Case	$R_{thJC}$	–	1.9	–	K/W	1) 2)
4.3.2	Junction to Ambient (2s2p)	$R_{thJA(2s2p)}$	–	25	–	K/W	1) 3)
4.3.3	Junction to Ambient (1s0p+600mm <sup>2</sup> Cu)	$R_{thJA(1s0p)}$	–	38	–	K/W	1) 4)

- 1) Not subject to production test, specified by design
- 2) Specified  $R_{thJC}$  value is simulated at natural convection on a cold plate setup (all pins are fixed to ambient temperature).  $T_C = 85\text{ °C}$ . Device is loaded with 1W power.
- 3) Specified  $R_{thJA}$  value is according to Jedec JESD51-2,-5,-7 at natural convection on FR4 2s2p board; The product (Chip+Package) was simulated on a 76.2 x 114.3 x 1.5 mm board with 2 inner copper layers (2 x 70µm Cu, 2 x 35µm Cu). Where applicable a thermal via array under the exposed pad contacted the first inner copper layer.  $T_a = 85\text{ °C}$ , Device is loaded with 1W power.
- 4) Specified  $R_{thJA}$  value is according to Jedec JESD51-2,-5,-7 at natural convection on FR4 1s0p board; The product (Chip+Package) was simulated on a 76.2 x 114.3 x 1.5 mm board with additional heatspreading copper area of 600mm<sup>2</sup> and 70 µm thickness.  $T_a = 85\text{ °C}$ , Device is loaded with 1W power.

#### 4.3.1 PCB set up

The following PCB set up was implemented to determine the transient thermal impedance.

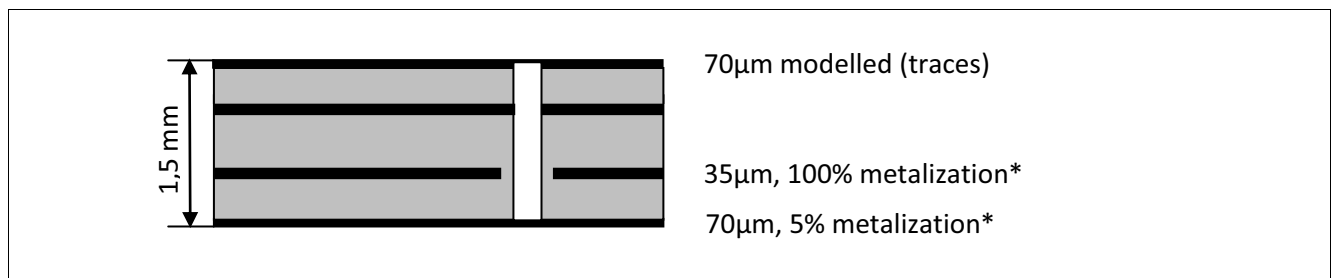

**Figure 4 Cross section JEDEC2s2p.**

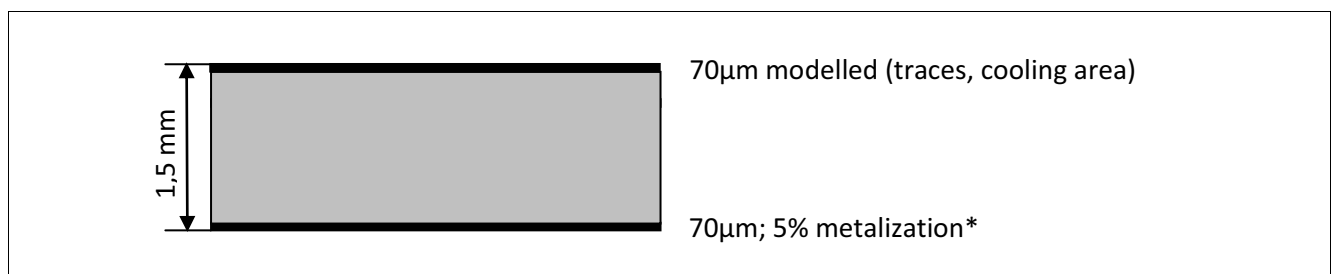

**Figure 5 Cross section JEDEC1s0p.**

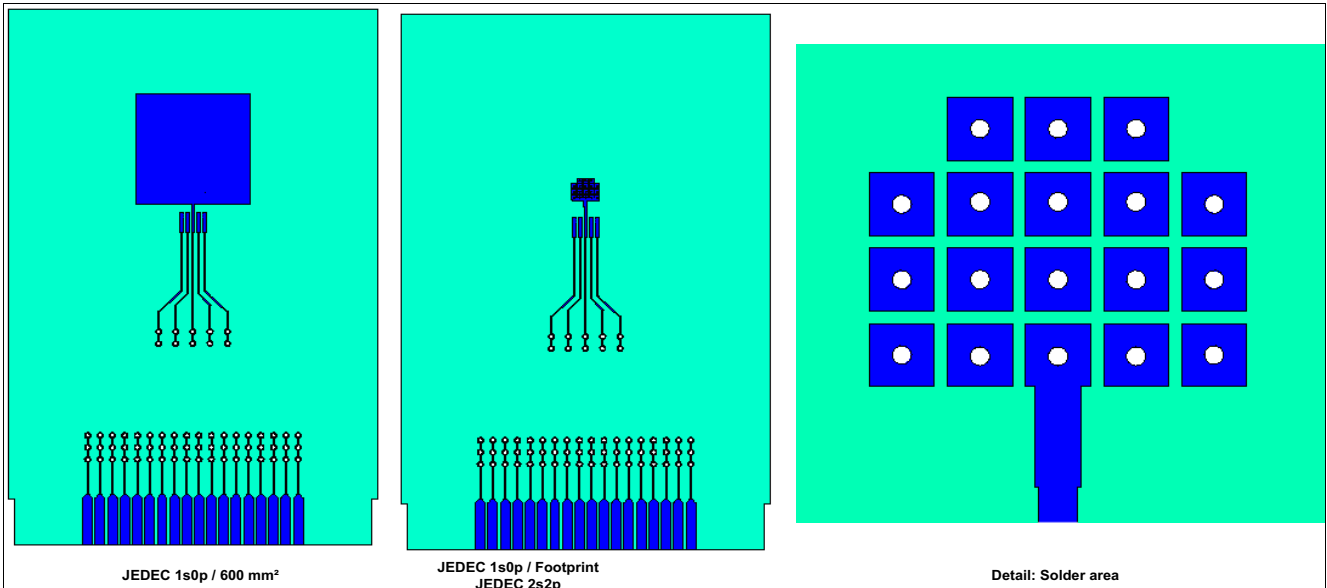

Figure 6 PCB layout

### 4.3.2 Transient Thermal Impedance

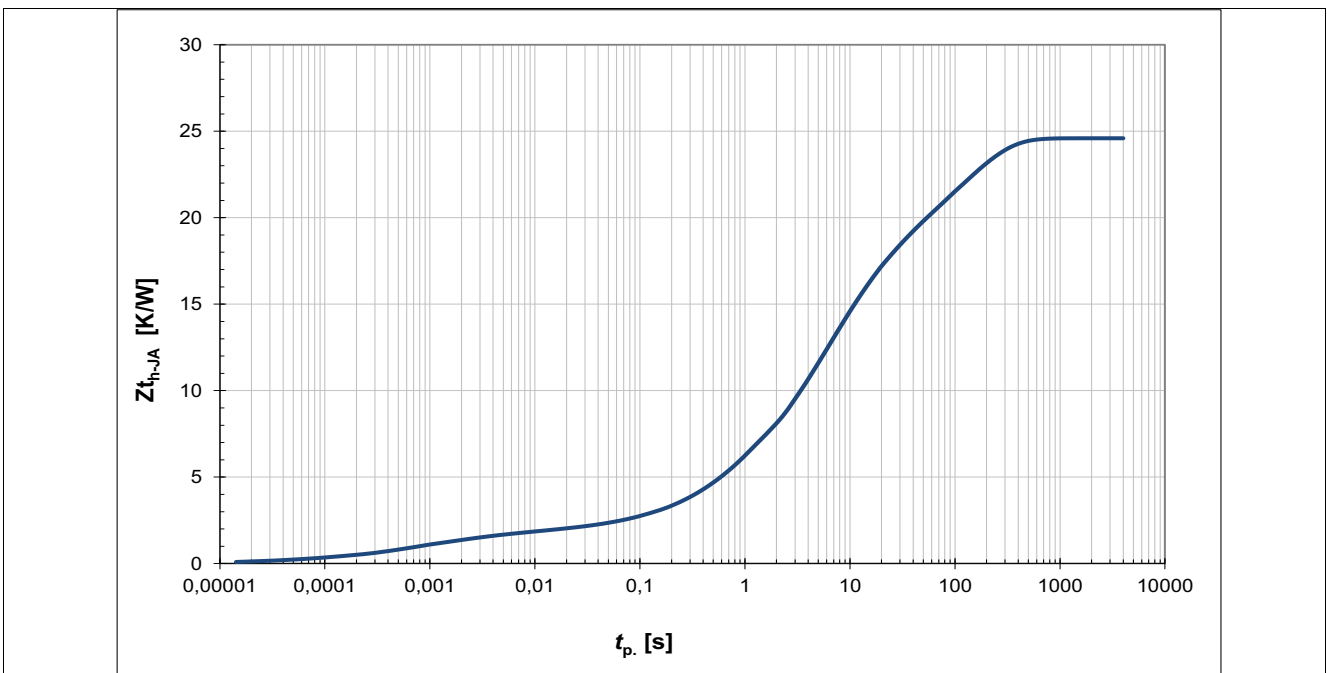
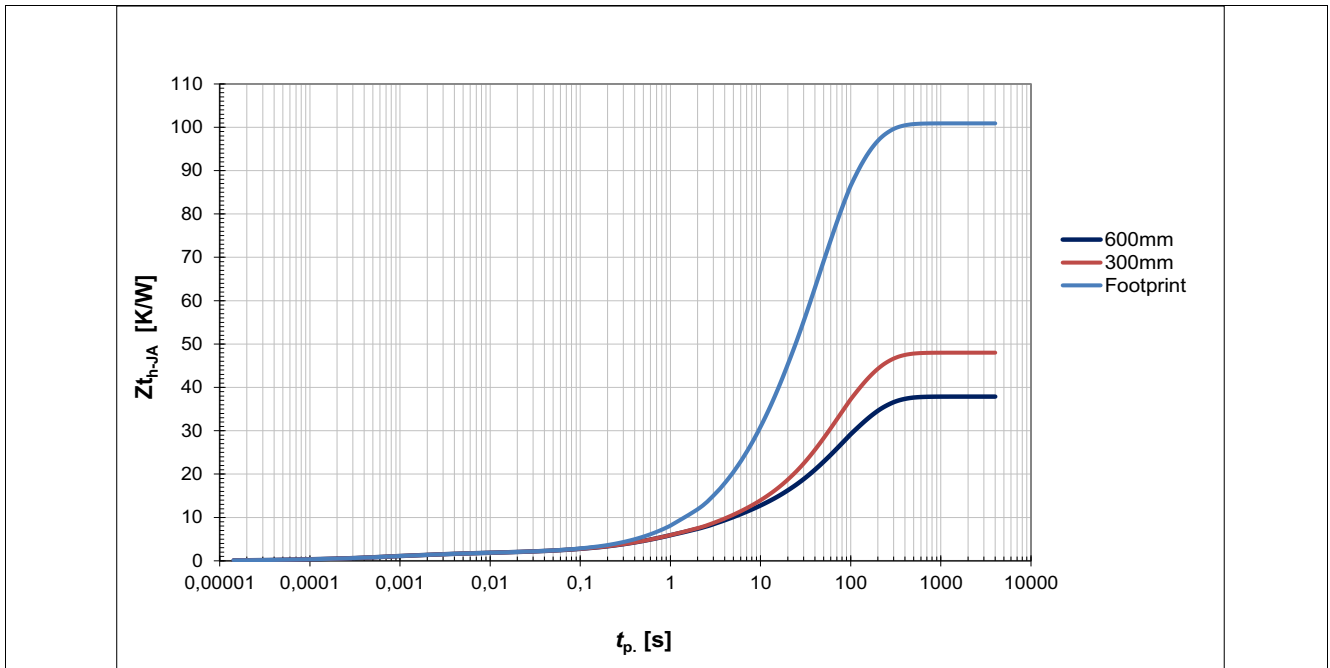

Figure 7 Typical transient thermal impedance  $Z_{thJA} = f(t_p)$ ,  $T_a = 85\text{ °C}$   
Value is according to Jecdec JESD51-2,-7 at natural convection on FR4 2s2p board; The product (Chip+Package) was simulated on a 76.2 x 114.3 x 1.5 mm<sup>3</sup> board with 2 inner copper layers (2 x 70 mm Cu, 2 x 35 mm Cu). Where applicable a thermal via array under the exposed pad contacted the first inner copper layer. Device is dissipating 1 W power.

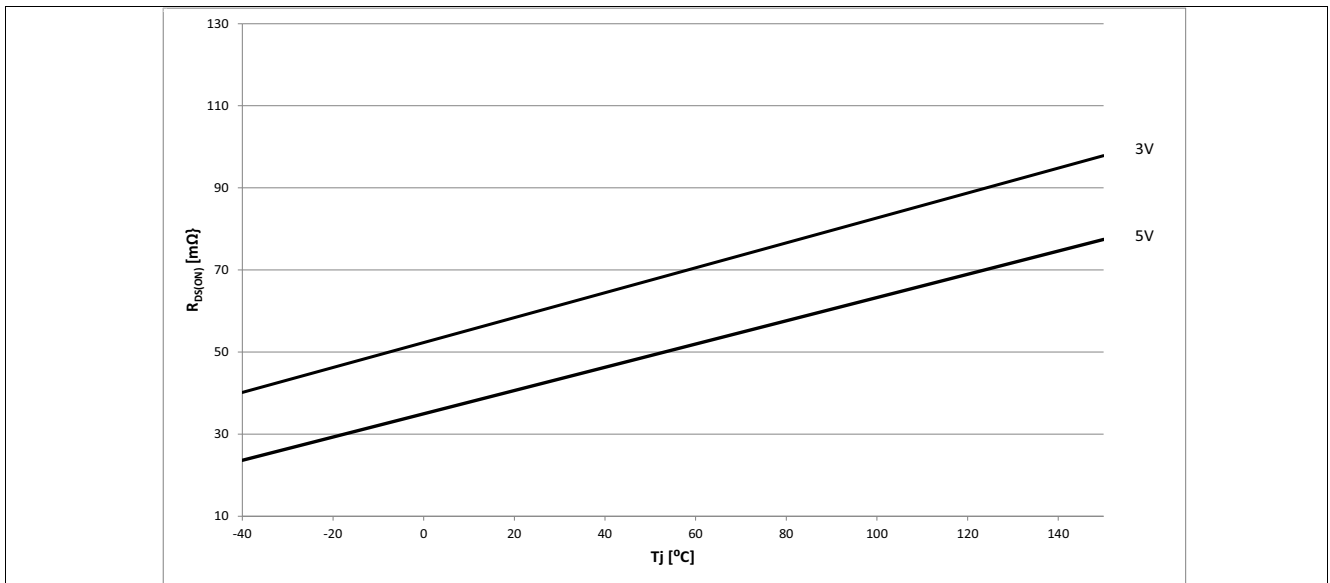

**Figure 8** Typical transient thermal impedance  $Z_{thJA} = f(t_p)$ ,  $T_a = 85\text{ °C}$   
Value is according to Jedec JESD51-3 at natural convection on FR4 1s0p board. Device is dissipating 1 W power.

## 5 Power Stage

### 5.1 Output On-state Resistance

The on-state resistance depends on the supply voltage as well as on the junction temperature  $T_J$ . **Figure 9** shows this dependencies in terms of temperature and voltage for the typical on-state resistance  $R_{DS(ON)}$ . The behavior in reverse polarity is described in chapter **“Reverse/Inverse Current Capability” on Page 14**.

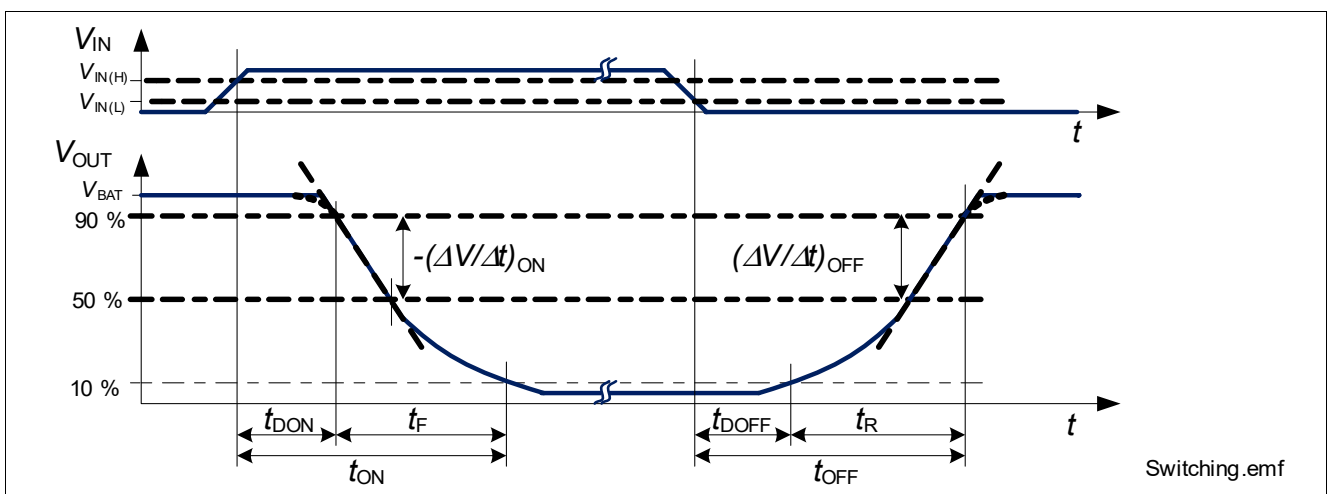

**Figure 9** Typical On-State Resistance,  
 $R_{DS(ON)} = f(T_J)$ ,  $V_{DD} = 5\text{ V}$ ,  $V_{DD} = 3\text{ V}$ ,  $V_{IN} = \text{high}$

A high signal at the input pin causes the power DMOS to switch ON with a dedicated slope. To achieve a reasonable  $R_{DS(ON)}$  and the specified switching speed a 5V supply is required.

### 5.2 Resistive Load Output Timing

**Figure 10** shows the typical timing when switching a resistive load.



**Figure 10** Definition of Power Output Timing for Resistive Load

### 5.3 Inductive Load

#### 5.3.1 Output Clamping

When switching off inductive loads with low side switches, the drain-source voltage  $V_{OUT}$  rises above battery potential, because the inductance intends to continue driving the current. To prevent unwanted high voltages the device has a voltage clamping mechanism to keep the voltage at  $V_{OUT(CLAMP)}$ . During this clamping operation mode the device heats up as it dissipates the energy from the inductance. Therefore the maximum allowed load inductance is limited. See [Figure 11](#) and [Figure 12](#) for more details.

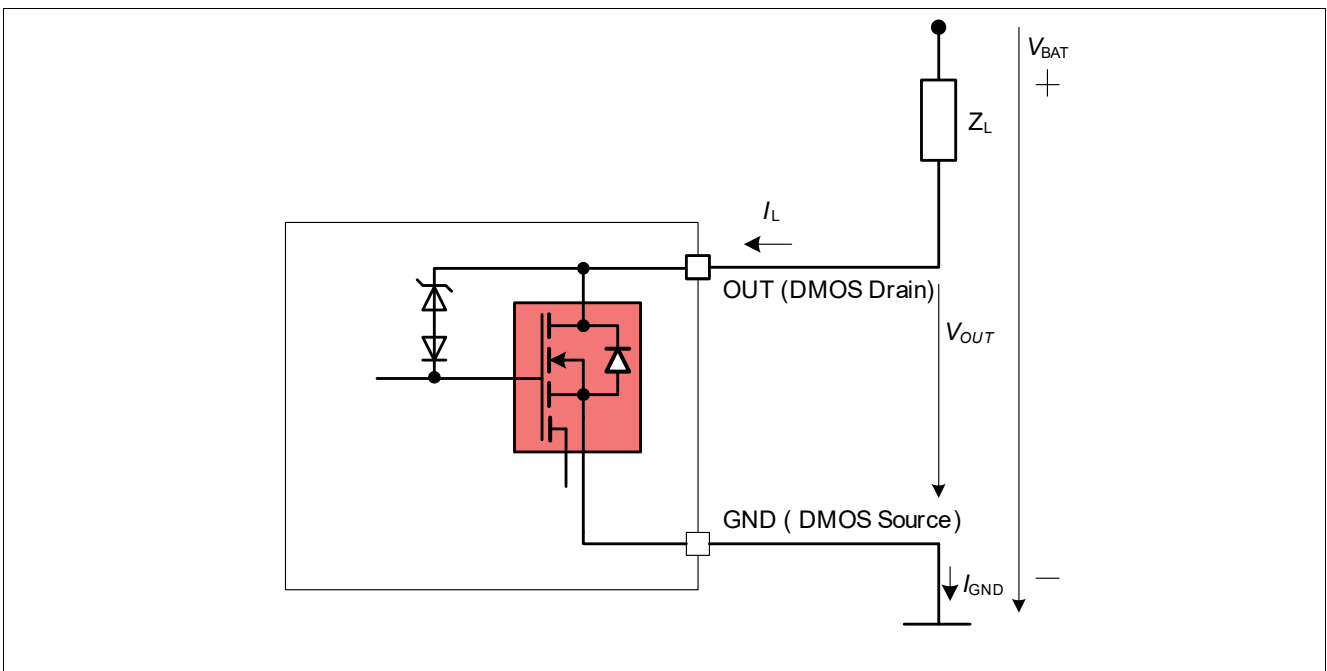

Figure 11 Output Clamp Circuitry

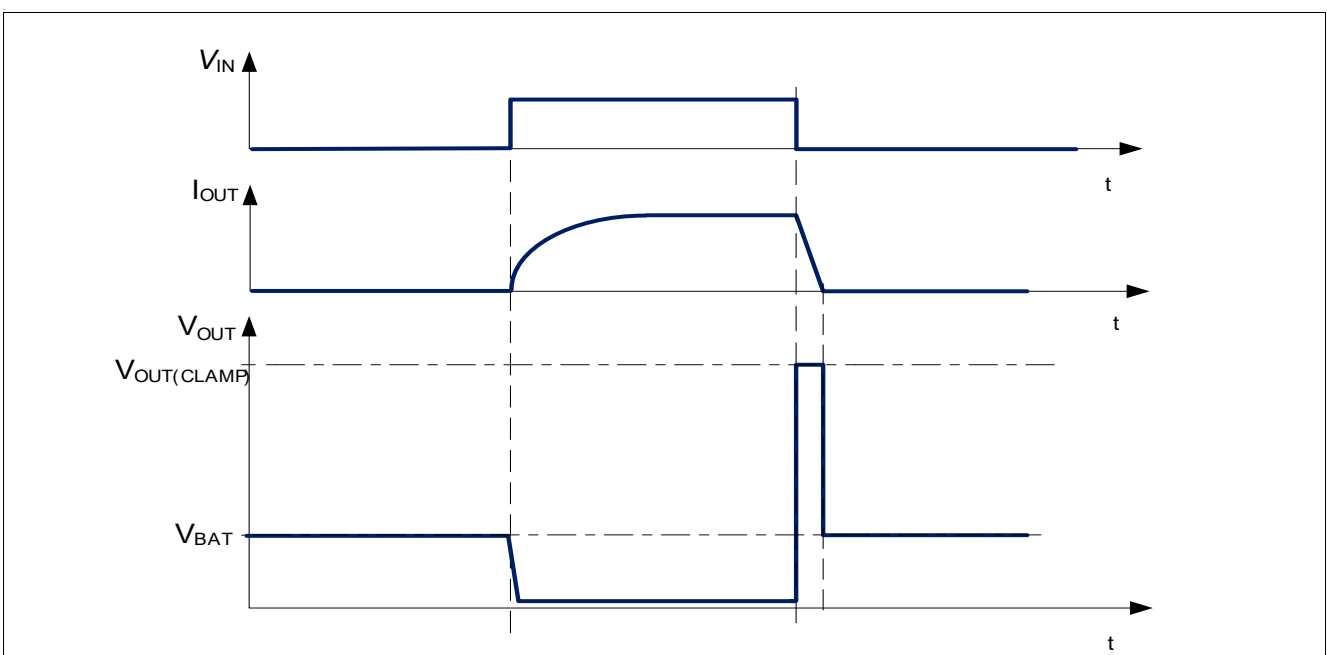

Figure 12 Switching an Inductive Load

Note: Repetitive switching of inductive load by  $V_{DD}$  instead of using the input is a not recommended operation and may affect the device reliability and reduce the lifetime.

### 5.3.2 Maximum Load Inductance

While demagnetization of inductive loads, energy has to be dissipated in the BTF3050TE. This energy can be calculated by the following equation:

$$E = V_{OUT(CLAMP)} \cdot \left[ \frac{V_{BAT} - V_{OUT(CLAMP)}}{R_L} \cdot \ln \left( 1 - \frac{R_L \cdot I_L}{V_{BAT} - V_{OUT(CLAMP)}} \right) + I_L \right] \cdot \frac{L}{R_L}$$

Following equation simplifies under assumption of  $R_L = 0$

$$E = \frac{1}{2} L I_L^2 \cdot \left( 1 - \frac{V_{BAT}}{V_{BAT} - V_{OUT(CLAMP)}} \right)$$

Figure 13 shows the inductance / current combination the BTF3050TE can handle.

For maximum single avalanche energy please also refer to  $E_{AS}$  value in “Energies” on Page 7

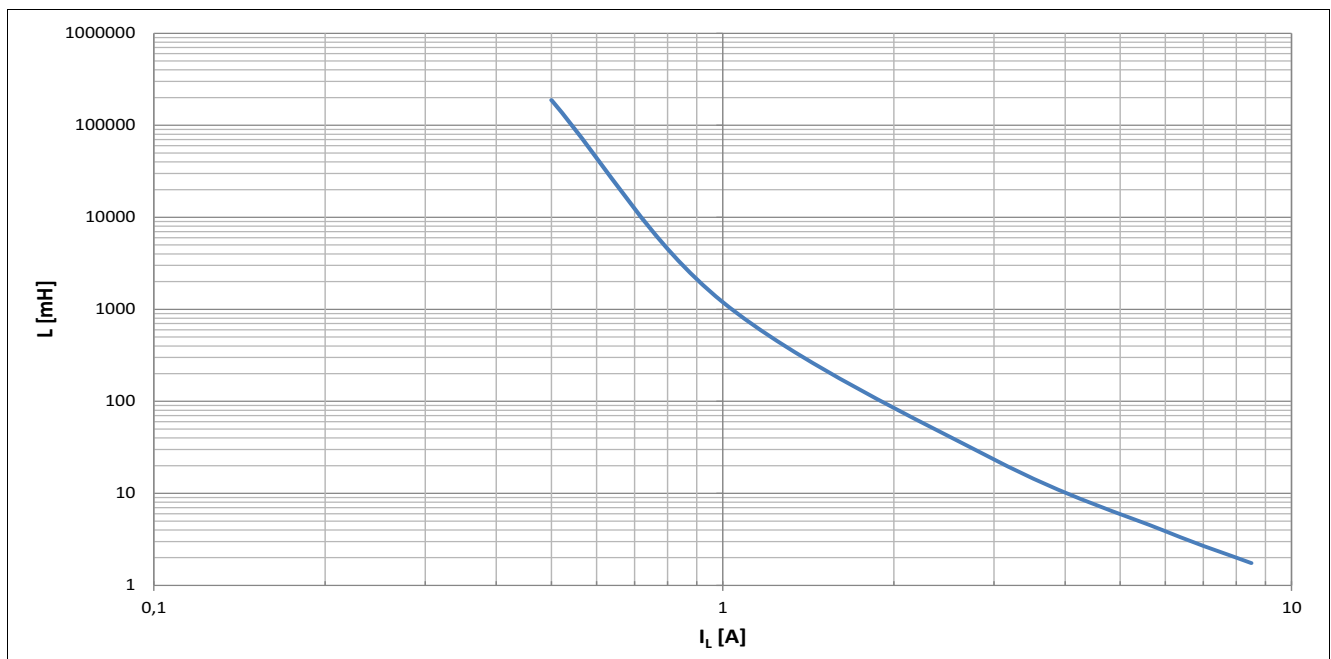

**Figure 13 Maximum load inductance for single pulse**  
 $L = f(I_L)$ ,  $T_{J,start} = 150\text{ °C}$ ,  $V_{BAT} = 13.5\text{ V}$

### 5.4 Reverse/Inverse Current Capability

A reverse battery situation means the OUT pin is pulled below GND potential to  $-V_{BAT}$  via the load  $Z_L$ .

In this situation the load is driven by a current through the intrinsic body diode of the BTF3050TE and all protection, such as current limitation, over temperature or over voltage clamping, are inactive.

In certain application cases (for example, usage in a bridge or half-bridge configuration) the intrinsic reverse body diode is used for freewheeling of an inductive load. In this case the device is still supplied but an inverse current is flowing from GND to OUT(drain) and the OUT will be pulled below GND.

In inverse or reverse operation via the reverse body diode, the device is dissipating a power loss which is defined by the driven current and the voltage drop on the body diode  $-V_{DS}$ .

During inverse current, an increased supply current  $I_{DD}$  flowing into  $V_{DD}$  needs to be considered. The device might be reset by inverse current.

## 5.5 Adjustable Switching Speed / Slew Rate

In order to optimize electromagnetic emission, the switching speed of the MOSFET can be adjusted by connecting an external resistor between SRP pin and GND. This allows for balancing between electromagnetic emissions and power dissipation. Shorting the SRP pin to GND represents the fastest switching speed. Open SRP pin represents the slowest switching speed. It is recommended to put a high ohmic resistor like 200k $\Omega$  on this SRP pin to GND. The accuracy of the switching speed adjustment is dependent on the precision of the external resistor used. It's recommended to use accurate resistors.

Figure 14 shows the simplified relation between the resistor value and the switching times.

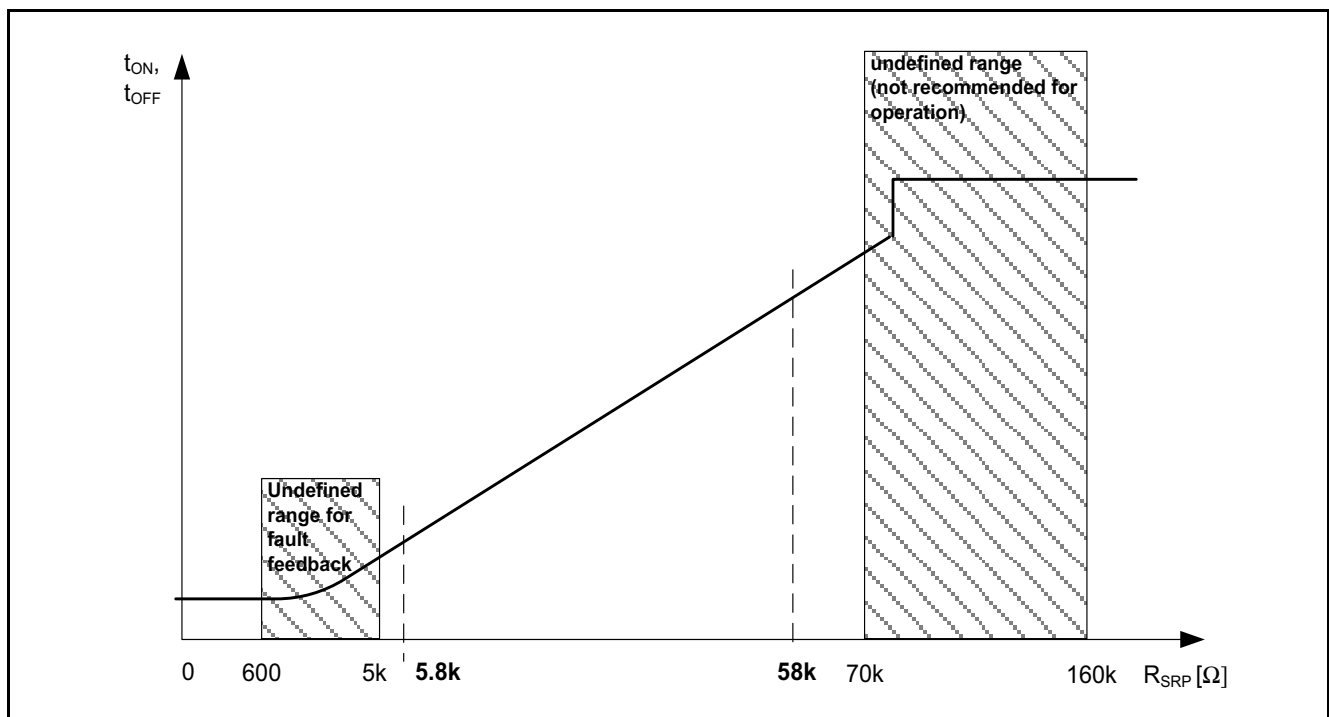

Figure 14 Typical simplified relation between switching time and  $R_{SRP}$  resistor values used on SRP pin ( $V_{BAT} = 13.5V$ )

It is not recommended to change the slew rate resistance during switching (supplied device,  $V_{DD} > V_{DD(UV\_ON)}$ ). Otherwise undefined switching behavior can occur.

### Slew Rate in Fault mode (fault signal set):

Beside the normal slew rate function the SRP pin is also used as fault feedback output. In case of a latched fault caused by over temperature detection the SRP pin will be internally pulled to  $V_{DD}$ . For details please refer to [“Functional Description of the SRP Pin” on Page 21](#). In this operation mode (latched fault signal) the slew rate control by  $R_{SRP}$  will be ignored and the switching speed (dynamic characteristics) will be set to fault mode default values. As long as the fault signal is set and the SRP-pin is not shorted to GND a fast default slew rate adjustment (like for  $R_{SRP} = 5.8k\Omega$ ) will be applied to the device.

If the SRP pin will be externally pulled up above the normal SRP pin voltage  $V_{SRP(NOR)}$  (e.g. to  $V_{DD}$ ) the slowest slew rate settings will be applied.

## **5.6 Characteristics**

Please see [“Power Stage” on Page 25](#) for electrical characteristic table.



## 6 Protection Functions

The device provides embedded protection functions. Integrated protection functions are designed to prevent IC destruction under fault conditions described in the datasheet. Fault conditions are considered as “outside” normal operating range. Protection functions are not to be used for continuous or repetitive operation. Over temperature is indicated by a high-logic active fault signal on the SRP pin.

### 6.1 Over Voltage Clamping on OUTput

The BTF3050TE is equipped with a voltage clamp circuitry that keeps the drain-source voltage  $V_{DS}$  at a certain level  $V_{OUT(CLAMP)}$ . The over voltage clamping is overruling the other protection functions. Power dissipation has to be limited to keep the maximum allowed junction temperature.

This function is also used in terms of inductive clamping. Please see also **“Output Clamping” on Page 13** for more details.

### 6.2 Thermal Protection with Latched Fault Signal

The device is protected against over temperature due to overload and/or bad cooling conditions by an integrated temperature sensor. The thermal protection is available if the device is active. .

The device incorporates an absolute ( $T_{J(SD)}$ ) and a dynamic temperature limitation ( $\Delta T_{J(SW)}$ ). Triggering one of them will cause the output to switch off.

The switch off will be done with the fastest possible slew rate. The BTF3050TE has a thermal-restart function. If input (IN) is still high the device will turn on again after the junction temperature has dropped below the thermal hysteresis.

In case of detected over temperature the fault signal will be set and the SRP pin will be internally pulled up to  $V_{DD}$ . This state is latched independent on the IN signal, providing a stable fault signal to be read out by a micro controller. The latched fault signal needs to be reset by low signal ( $V_{SRP} < V_{SRP(RESET\_MIN)}$ ) at the SRP pin, provided that the junction temperature has decreased at least below the thermal hysteresis in the meantime. To reliably reset the latch the SRP pin needs to be pulled down with a minimum length of  $t_{RESET}$ .

As long as the fault signal is set and the SRP-pin is not shorted to GND a fast default slew rate adjustment (like for  $R_{SRP} = 5.8k\Omega$ ) will be applied to the device.

If the latched fault signal is not reset, the device logic stays active (also if IN = low) not entering the quiescent current mode and therefore reaching upper limits of normal supply current  $I_{DD}$ .

Please see **“Diagnostics” on Page 21** for details on the feedback and reset function.

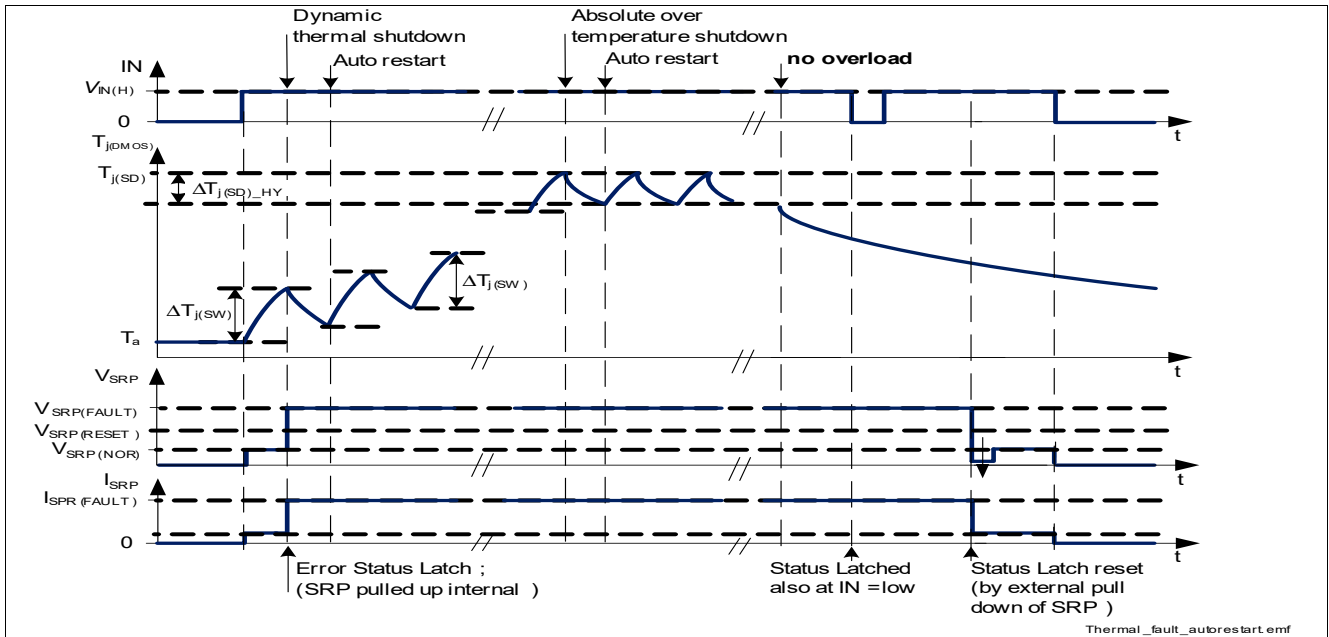

**Figure 15 Thermal protective switch OFF scenario for case of overload or short circuit**

Note: For better understanding, the time scale is not linear. The real timing of this drawing is application dependant.

### 6.3 Overcurrent Limitation / Short Circuit Behavior

This device is providing a smart overcurrent limitation which provides protection against short circuit conditions while allowing also load inrush currents higher than the current limitation level. To achieve this the device has a current limitation level  $I_{L(LIM)}$  which is triggered by a higher trigger level  $I_{L(LIM)\_TRIGGER}$ .

The condition short circuit is an overload condition to the device.

If the load current  $I_L$  reaches the current limitation trigger level  $I_{L(LIM)\_TRIGGER}$  the internal current limitation will be activated and the device limits the current to a lower value  $I_{L(LIM)}$ . The device starts heating up. When the thermal shutdown temperature  $T_{J(SD)}$  is reached, the device turns off. The time from the beginning of current limitation until the over temperature switch off depends strongly on the cooling conditions.

If input is still high the device will turn on again after the measured temperature has dropped below the thermal hysteresis. The current limitation trigger is a latched signal. It will be only reset by input (IN) pin low and resetting the fault latch (SRP-pin = low (below reset threshold)) at the same time. This means if the input stays high all the time during short circuit the current will be limited to  $I_{L(LIM)}$  the following pulses (during thermal restart). It also means that the output current is limited to the current limitation level  $I_{L(LIM)}$  until the current limitation trigger is not reset.

Figure 16 shows this behavior.

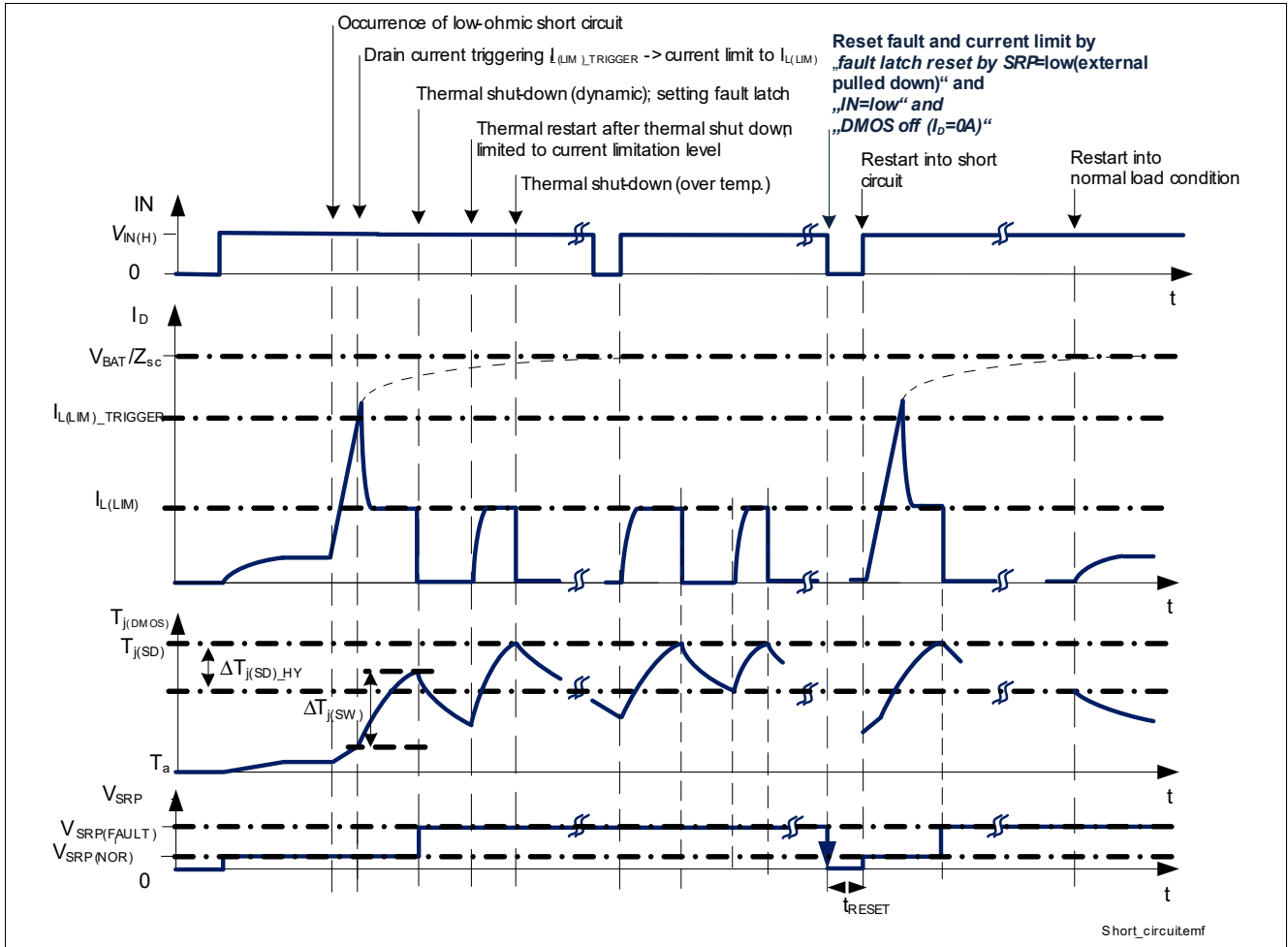

**Figure 16** Short circuit protection via current limitation and thermal switch off, with latched fault signal on SRP (valid for  $R_{SRP} = 5...70 \text{ k}\Omega$ )

Note: For better understanding, the time scale is not linear. The real timing of this drawing is application dependant.

#### Behavior with overload current below current limitation trigger level

The lower current limitation level  $I_{L(LIM)}$  will be also triggered by an thermal shutdown. This could be the case in terms of overload with a current still below the overcurrent limitation trigger level ( $I_L < I_{L(LIM)_TRIGGER}$ ).

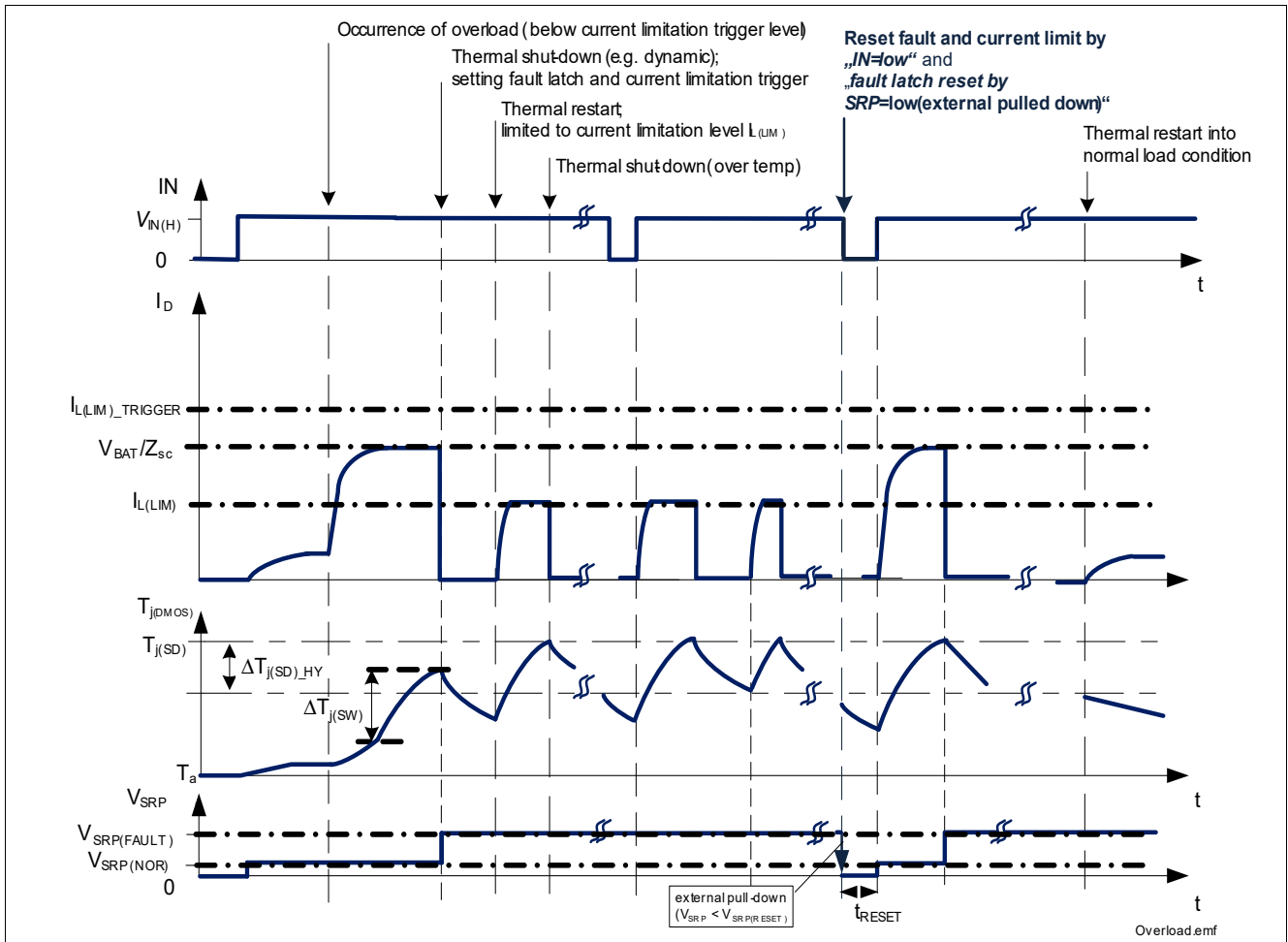

Figure 17 Example of overload behavior with thermal shutdown

Note: For better understanding, the time scale is not linear. The real timing of this drawing is application dependant.

## 6.4 Characteristics

Figure 18 Please see “Protection” on Page 26 for electrical characteristic table.

## 7 Diagnostics

The BTF3050TE provides a latching digital fault feedback signal on the SRP pin triggered by an over temperature shutdown.

Additionally the device features an adjustable slew rate via the SRP pin.

### 7.1 Functional Description of the SRP Pin

The BTF3050TE provides digital status information via the combined status and Slew-Rate-Preset pin (SRP). This pin has three modes of operation:

#### Normal operation mode (slew rate mode; low signal)

The pin is used to define the switching speed of the BTF3050TE.

A resistor to ground defines the strength of the gate driver stage used to switch the power DMOS. The SRP pin works as a controlled low voltage output with a normal voltage up to  $V_{SRP(NOR)}$ , driving from  $V_{DD}$  a current out of the SRP-pin through the slew rate adjustment resistor.

For details on this function please refer to [“Adjustable Switching Speed / Slew Rate” on Page 15](#).

The voltage on the SRP pin in normal operation mode is  $V_{SRP(NOR)}$ , signaling a low signal to the micro controller.

#### Latched Feedback mode (internal pull-up to $V_{DD}$ ; high signal)

The pin is used to give an alarming feedback to the micro controller after an over temperature shut down.

The SRP pin is pulled to  $V_{DD}$  by an active internal pull-up source providing typical a current  $I_{SRP(FAULT)}$ , intend to signal a logic high to the micro controller. This mode stays active independent from the input pin state or internal restarts until it will be reset (see below).

During this mode the slew rate of the device is set to a fast “fault” mode slew rate (similar to the switching times at  $R_{SRP} = 5.8k\Omega$ .) The latched fault/feedback mode and signal is available at slew rate resistors of  $5k\Omega < R_{SRP} < 70k\Omega$ . (please see also [Figure 21 “Availability of latched fault/feedback mode in dependency of slew rate resistor RSRP” on Page 22](#))

#### Reset Latch (external pull-down)

The pin is used as an input pin to set the device back to normal mode and reset the fault latch.

To reset the device the voltage on the SRP pin needs to be forced below the reset threshold  $V_{SRP(RESET)}$  by an external pull down (e.g. using the micro controller I/O as pull-down).

If the SRP pin will be pulled down below  $V_{SRP(RESET)}$  for a minimum time of  $t_{RESET}$  the logic resets the feedback latch, provided that its temperature has decreased at least the thermal hysteresis  $\Delta T_{j(SW\_HYS)}$  in the meantime.

If INput is pulled down as well the current limitation trigger level will be also reset (enabling high peak currents again).

[Figure 19](#) is showing the simplified circuitry used.

As long as the latched fault signal is not reset, the device logic stays active (also if IN = low) not entering the quiescent current mode.



## 8 Supply and Input Stage

### 8.1 Supply Circuit

The supply pin  $V_{DD}$  is protected against ESD pulses as shown in [Figure 22](#).

The device supply is not internal regulated but directly taken from an external supply. Therefore a reverse polarity protected and buffered 5V (or 3.3V) voltage supply is required. To achieve a reasonable  $R_{DS(ON)}$  and the specified switching speed, a 5V (or 3.3V) supply is required.

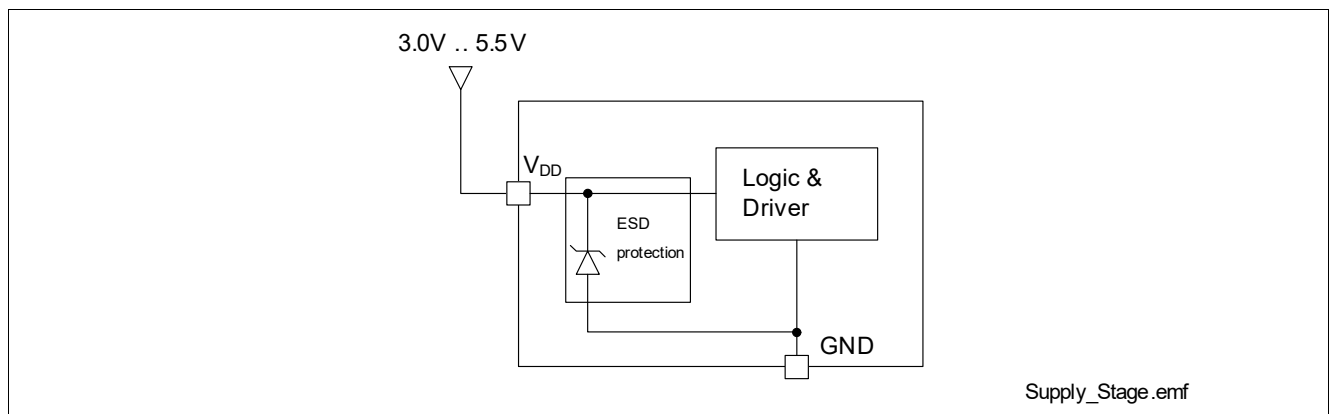

**Figure 22** Supply Circuit

#### 8.1.1 Undervoltage Shutdown

In order to ensure a stable and defined device behavior under all allowed conditions the supply voltage  $V_{DD}$  is monitored.

The output switches off, if the supply voltage  $V_{DD}$  drops below the switch-off threshold  $V_{DD(TH)}$ . In this case also all latches will be reset. The device functions are only given for supply voltages above the supply voltage threshold  $V_{DD(TH)}$ . There is no failure feedback ensured for  $V_{DD} < V_{DD(TH)}$ .

### 8.2 Input Circuit

[Figure 23](#) shows the input circuit of the BTF3050TE. Due to an internal pull-down it is ensured that the device switches off in case of an open input pin. A Zener structure protects the input circuit against ESD pulses. As the BTF3050TE has a supply pin, the  $R_{DS(ON)}$  of the power MOS is independent of the voltage on the IN pin (assumed  $V_{DD}$  is sufficient).

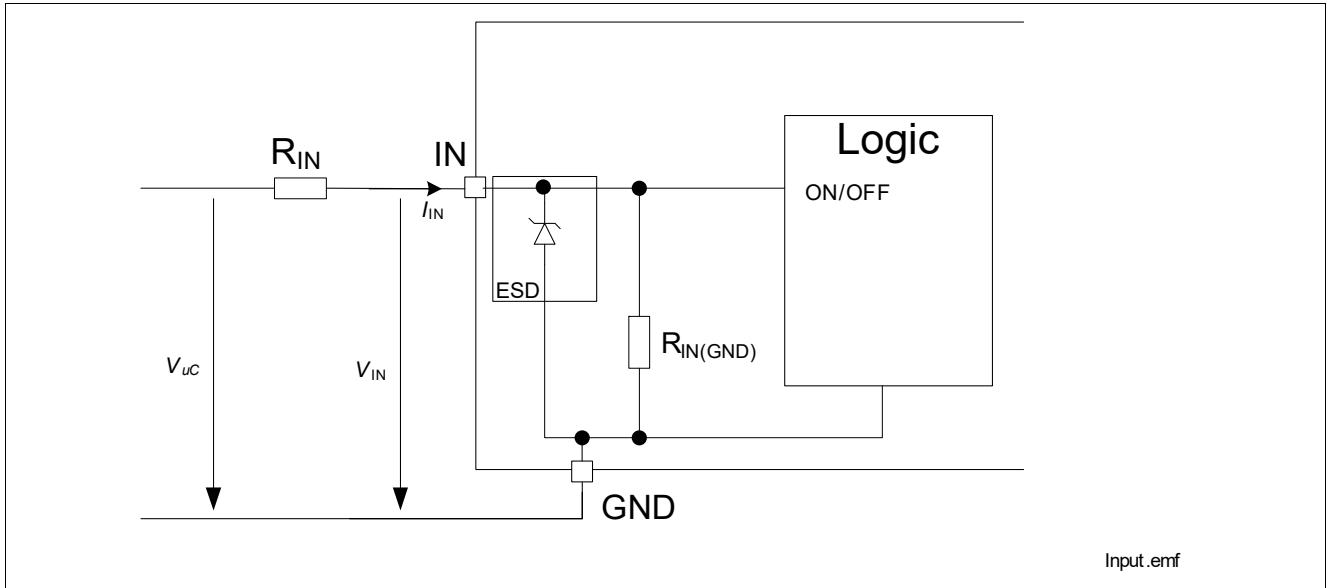

Figure 23 Simplified input circuitry

### 8.3 Characteristics

Please see [“Supply and Input Stage” on Page 29](#) for electrical characteristic table.



## 9 Electrical Characteristics

Note: Characteristics show the deviation of parameter at given input voltage and junction temperature.

Typical values show the typical parameters expected from manufacturing and in typical application condition.

All voltages and currents naming and polarity in accordance to

[Figure 3 "Naming Definition of electrical parameters" on Page 6](#)

### 9.1 Power Stage

Please see Chapter ["Power Stage" on Page 12](#) for parameter description and further details.

**Table 5 Electrical Characteristics: Power Stage**

$T_J = -40\text{ °C}$  to  $+150\text{ °C}$ ,  $V_{DD} = 3.0\text{ V}$  to  $5.5\text{ V}$ ,  $V_{BAT} = 8\text{ V}$  to  $18\text{ V}$ , all voltages with respect to ground, positive current flowing into pin (unless otherwise specified)

Pos.	Parameter	Symbol	Limit Values			Unit	Note / Test Condition
			Min.	Typ.	Max.		
<b>Power Stage - Static Characteristics</b>							
9.1.1	On-State resistance	$R_{DS(ON)}$	–	40	–	mΩ	$I_L = I_{L(NOM)}$ ; $V_{DD} = 5\text{ V}$ ; $T_J = 25\text{ °C}$
			–	80	100	mΩ	$I_L = I_{L(NOM)}$ ; $V_{DD} = 5\text{ V}$ ; $T_J = 150\text{ °C}$
9.1.2	Nominal load current	$I_{L(NOM)}$	–	3.0	–	A	<sup>1)</sup> $T_J < 150\text{ °C}$ ; $V_{DD} = 5\text{ V}$ ;
9.1.3	OFF state load current, Output leakage current	$I_{L(OFF)}$	–	–	2	μA	<sup>2)</sup> $V_{OUT} = V_{BAT} = 13.5\text{ V}$ ; $V_{IN} = 0\text{ V}$ ; $V_{DD} = 5\text{ V}$ ; $T_J \leq 85\text{ °C}$
	OFF state load current, Output leakage current	$I_{L(OFF)}$	–	–	1	μA	$V_{OUT} = V_{BAT} = 13.5\text{ V}$ ; $V_{IN} = 0\text{ V}$ ; $V_{DD} = 5\text{ V}$ ; $T_J = 25\text{ °C}$
	OFF state load current, Output leakage current	$I_{L(OFF)}$	–	1.5	4	μA	$V_{OUT} = V_{BAT}$ ; $V_{IN} = 0\text{ V}$ ; $V_{DD} = 5\text{ V}$ ; $T_J = 150\text{ °C}$
<b>Reverse Diode</b>							
9.1.4	Reverse diode forward voltage	$-V_{DS}$	–	1.0	–	V	$T_J = -40\text{ °C}$ $I_D = -I_{L(NOM)}$ ; $V_{IN} = 0\text{ V}$
			–	0.8	–		$T_J = 25\text{ °C}$ $I_D = -I_{L(NOM)}$ ; $V_{IN} = 0\text{ V}$
			–	0.7	1.0		$T_J = 150\text{ °C}$ $I_D = -I_{L(NOM)}$ ; $V_{IN} = 0\text{ V}$

**Table 5 Electrical Characteristics: Power Stage (cont'd)**
 $T_j = -40\text{ °C to }+150\text{ °C}$ ,  $V_{DD} = 3.0\text{ V to }5.5\text{ V}$ ,  $V_{BAT} = 8\text{ V to }18\text{ V}$ , all voltages with respect to ground, positive current flowing into pin (unless otherwise specified)

Pos.	Parameter	Symbol	Limit Values			Unit	Note / Test Condition
			Min.	Typ.	Max.		

**Power Stage - Dynamic characteristics - switching time adjustment**
 $V_{BAT} = 13.5\text{ V}$ ;  $V_{DD} = 5\text{ V}$ ; resistive load:  $R_L = 4.7\text{ }\Omega$ ;  $C_{SRP-GND} < 100\text{ pF}$ ;

 see [Figure 10 "Definition of Power Output Timing for Resistive Load" on Page 12](#) for definition details

9.1.5	Turn-on delay time	$t_{DON}$	2	4	7.5	$\mu\text{s}$	$R_{SRP} = 0\text{ }\Omega$
			2.5	5	8.5	$\mu\text{s}$	$R_{SRP} = 5.8\text{ k}\Omega$
			5	10	15	$\mu\text{s}$	$R_{SRP} = 58\text{ k}\Omega$
9.1.6	Turn-off delay time	$t_{DOFF}$	2	4	7.5	$\mu\text{s}$	$R_{SRP} = 0\text{ }\Omega$
			2.5	5	8.5	$\mu\text{s}$	$R_{SRP} = 5.8\text{ k}\Omega$
			10	20	30	$\mu\text{s}$	$R_{SRP} = 58\text{ k}\Omega$
9.1.7	Turn-on output fall time	$t_F$	0.65	1.3	2.0	$\mu\text{s}$	$R_{SRP} = 0\text{ }\Omega$
			1	2	3	$\mu\text{s}$	$R_{SRP} = 5.8\text{ k}\Omega$
			10	20	30	$\mu\text{s}$	$R_{SRP} = 58\text{ k}\Omega$
9.1.8	Turn-off output rise time	$t_R$	0.65	1.3	2.0	$\mu\text{s}$	$R_{SRP} = 0\text{ }\Omega$
			1	2	3	$\mu\text{s}$	$R_{SRP} = 5.8\text{ k}\Omega$
			10	20	30	$\mu\text{s}$	$R_{SRP} = 58\text{ k}\Omega$
9.1.9	Turn-on <i>Slew rate</i> <sup>3)</sup>	$-(\Delta V/\Delta t)_{ON}$	11	22	33	$\text{V}/\mu\text{s}$	$R_{SRP} = 0\text{ }\Omega$
			7	13	21	$\text{V}/\mu\text{s}$	$R_{SRP} = 5.8\text{ k}\Omega$
			0.7	1.4	2	$\text{V}/\mu\text{s}$	$R_{SRP} = 58\text{ k}\Omega$
9.1.10	Turn-off <i>Slew rate</i> <sup>3)</sup>	$(\Delta V/\Delta t)_{OFF}$	11	22	33	$\text{V}/\mu\text{s}$	$R_{SRP} = 0\text{ }\Omega$
			7	13	21	$\text{V}/\mu\text{s}$	$R_{SRP} = 5.8\text{ k}\Omega$
			0.7	1.4	2	$\text{V}/\mu\text{s}$	$R_{SRP} = 58\text{ k}\Omega$

**Power Stage - Dynamic characteristics - Failure mode (latched fault signal set)<sup>4), 5)</sup>**
 $V_{BAT} = 13.5\text{ V}$ ;  $V_{DD} = 5\text{ V}$ ; resistive load:  $R_L = 4.7\text{ }\Omega$ ; latched fault set;

 see [Figure 10 "Definition of Power Output Timing for Resistive Load" on Page 12](#) for definition details;

 please refer to the [Power Stage - Dynamic characteristics - switching time adjustment](#) at  $R_{SRP} = 5.8\text{ k}\Omega$  (see above)

- 1) Not subject to production test, calculated by  $R_{thJA}$  and  $R_{DS(ON)}$ .
- 2) Not subject to production test, specified by design; tested at  $25\text{ °C}$
- 3) Not subject to production test, calculated slew rate between 90% and 50%;  $\Delta V/\Delta t = (V_{OUT(90\%)} - V_{OUT(50\%)}) / (t_{90\%} - t_{50\%})$
- 4) Not subject to production test, specified by design.
- 5) In case of over temperature switch-off the fast slew rate like  $R_{SRP} = 5.8\text{ k}\Omega$  will be applied.

## 9.2 Protection

 Please see Chapter ["Protection Functions" on Page 17](#) for parameter description and further details.

*Note: Integrated protection functions are designed to prevent IC destruction under fault conditions described in the data sheet. Fault conditions are considered as "outside" normal operating range. Protection functions are not designed for continuous repetitive operation*

**Table 6 Electrical characteristics: Protection**

$T_J = -40\text{ °C}$  to  $+150\text{ °C}$ ,  $V_{DD} = 3.0\text{ V}$  to  $5.5\text{ V}$ ,  $V_{BAT} = 8\text{ V}$  to  $18\text{ V}$ , all voltages with respect to ground, positive current flowing into pin (unless otherwise specified)

Pos.	Parameter	Symbol	Limit Values			Unit	Note / Test Condition
			Min.	Typ.	Max.		
<b>Thermal shut down <sup>1)</sup></b>							
9.2.1	Thermal shut down junction temperature	$T_{J(SD)}$	150	175	200	°C	<sup>1)</sup>
9.2.2	Thermal hysteresis	$\Delta T_{J(SD)\_HYS}$	–	15	–	K	<sup>1)</sup>
9.2.3	Dynamic temperature limitation	$\Delta T_{J(SW)}$	–	70	–	K	<sup>1)</sup>
<b>Over Voltage Protection / Clamping</b>							
9.2.4	Drain clamp voltage	$V_{OUT(CLAMP)}$	40	–	–	V	$V_{IN} = 0\text{ V}$ ; $I_D = 10\text{ mA}$ ; $V_{DD} = 5V$
<b>Current limitation</b>							
9.2.5	Current limitation trigger level	$I_{L(LIM)\_TRIGGER}$	30	45	60	A	$V_{IN} = 5\text{ V}$ ; $V_{DD} = 5V$ ; $V_{DS} = V_{BAT}$
9.2.6	Current limitation level	$I_{L(LIM)}$	8	15	20	A	$V_{IN} = 5\text{ V}$ ; $V_{DD} = 5V$ ; settled value; $V_{DS} = V_{BAT}$

<sup>1)</sup> Not subject to production test, specified by design.

### 9.3 Diagnostics

Please see Chapter “[Diagnostics](#)” on [Page 21](#) for description and further details.

**Table 7 Electrical Characteristics: Diagnostics**

$T_J = -40\text{ °C}$  to  $+150\text{ °C}$ ,  $V_{DD} = 3.0\text{ V}$  to  $5.5\text{ V}$ ,  $V_{BAT} = 8\text{ V}$  to  $18\text{ V}$ , all voltages with respect to ground, positive current flowing into pin (unless otherwise specified)

Pos.	Parameter	Symbol	Limit Values			Unit	Note / Test Condition
			Min.	Typ.	Max.		
<b>Feedback pin</b>							
9.3.1	allowed SRP pin voltage operation range	$V_{SRP}$	-0.3	–	5.5	V	$V_{SRP} < V_{DD}$
9.3.2	SRP voltage in normal operation during slew rate adjustment mode	$V_{SRP(NOR)}$	–	0.6	0.8	V	–
9.3.3	SRP voltage in fault feedback mode (latched)	$V_{SRP(FAULT)}$	0.7	–	1	$xV_{DD}$	$R_{SRP} > 5\text{ k}\Omega$ ; see also 9.3.4 fault feedback latched
9.3.4	SRP pull-up current in fault feedback mode	$I_{SRP(FAULT)}$	–	1.8	–	mA	$V_{DD} = 5\text{ V}$ ; $V_{BAT} > 13.5\text{ V}$ internal limited
9.3.5	Slew rate resistor range for normal operation, latched fault feedback available	$R_{SRP(NOR)}$	5	–	70	kΩ	<sup>1)</sup> latched fault available

**Table 7 Electrical Characteristics: Diagnostics (cont'd)**

$T_J = -40\text{ °C to }+150\text{ °C}$ ,  $V_{DD} = 3.0\text{ V to }5.5\text{ V}$ ,  $V_{BAT} = 8\text{ V to }18\text{ V}$ , all voltages with respect to ground, positive current flowing into pin (unless otherwise specified)

Pos.	Parameter	Symbol	Limit Values			Unit	Note / Test Condition
			Min.	Typ.	Max.		
9.3.6	Slew rate resistor range for extended operation, no latched fault feedback available	$R_{SRP(EXT)}$	0	–	600	$\Omega$	<sup>1)</sup> no latched fault available
9.3.7	Fault feedback reset threshold	$V_{SRP(RESET)}$	–	1.8	–	V	–
9.3.8	Fault feedback reset time	$t_{RESET}$	100	–	–	$\mu\text{s}$	<sup>1)</sup> $V_{SRP} < V_{SRP(RESET)}$ ; no over temperature

1) Not subject to production test, specified by design.

## 9.4 Supply and Input Stage

Please see Chapter [“Supply and Input Stage” on Page 23](#) for description and further details.

**Table 8 Electrical Characteristics: Supply and Input**

$T_j = -40\text{ °C}$  to  $+150\text{ °C}$ ,  $V_{DD} = 3.0\text{ V}$  to  $5.5\text{ V}$ ,  $V_{BAT} = 8\text{ V}$  to  $18\text{ V}$ , all voltages with respect to ground, positive current flowing into pin (unless otherwise specified)

Pos.	Parameter	Symbol	Limit Values			Unit	Note / Test Condition
			Min.	Typ.	Max.		
<b>Supply</b>							
9.4.1	Nominal supply voltage	$V_{DD(NOM)}$	3.0	5.0	5.5	V	–
9.4.2	Supply Undervoltage Shutdown Switch-on/off threshold voltage	$V_{DD(TH)}$	1.3	1.7	3.0	V	$V_{IN} = 5.0\text{ V}$
9.4.3	Supply current, continuous ON operation	$I_{DD(ON)}$	–	2.5	4	mA	device on-state $V_{DD} = 5.0\text{ V}$ $R_{SRP} = 0\ \Omega$ $I_{L(0)} = I_{L(NOM)}$ no fault signal
9.4.4	Supply current, continuous on operation with latched fault signal	$I_{DD(FAULT)}$	–	4.5	6	mA	DC condition, $V_{DD} = 5.0\text{ V}$ with fault signal
9.4.5	Supply current, inverse condition on OUT to GND	$I_{DD(-VOUT)}$	–	33	–	mA	<sup>1)</sup> ; $V_{OUT} < -0.3\text{ V}$ ;
9.4.6	Standby supply current	$I_{DD(OFF)}$	–	1.5	6	$\mu\text{A}$	$V_{IN} = 0\text{ V}$ $V_{DD} = 5.0\text{ V}$ $R_{SRP} = 0\ \Omega$ $T_j < 85\text{ °C}$ no fault signal
9.4.7	Standby supply current, maximum at 150°C	$I_{DD(OFF)_150}$	–	6	14	$\mu\text{A}$	$V_{IN} = 0\text{ V}$ $V_{DD} = 5.0\text{ V}$ $R_{SRP} = 0\ \Omega$ $T_j = 150\text{ °C}$ no fault signal
<b>Input</b>							
9.4.8	Low level input voltage	$V_{IN(L)}$	-0.3	–	0.8	V	–
9.4.9	High level input voltage	$V_{IN(H)}$	2.0	–	$V_{DD}$	V	–
9.4.10	Input voltage hysteresis	$V_{IN(HYS)}$	–	200	–	mV	–
9.4.11	Input pull down current	$I_{IN}$	–	–	160	$\mu\text{A}$	$2.7\text{ V} < V_{IN} < 5.5\text{ V}$ $-0.3\text{ V} < V_{DD} < 5.5\text{ V}$
9.4.12	Internal Input pull down resistor	$R_{IN(GND)}$	25	50	100	k $\Omega$	–

1) Not subject to production test, specified by design.

## 10 Characterisation Results

Typical performance characteristics

### 10.1 Power Stage

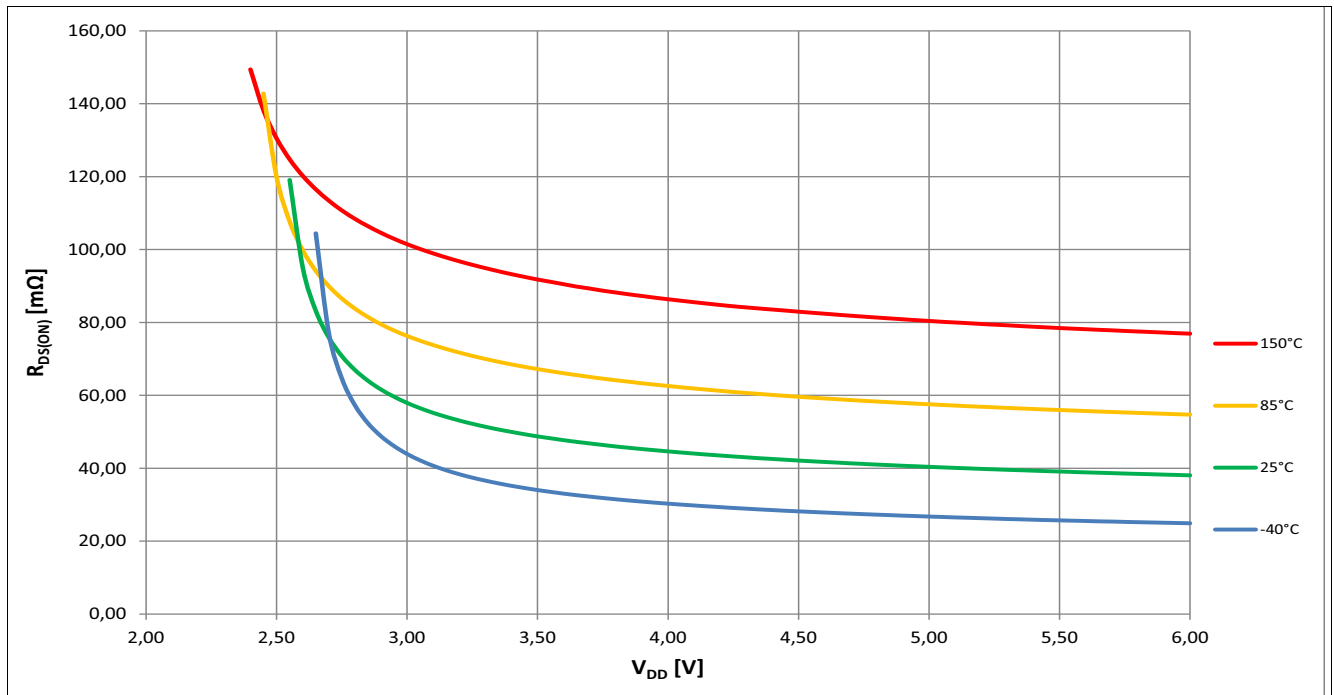

Figure 24 Typical  $R_{DS(ON)}$  vs.  $V_{DD}$  @  $I_L=3A$

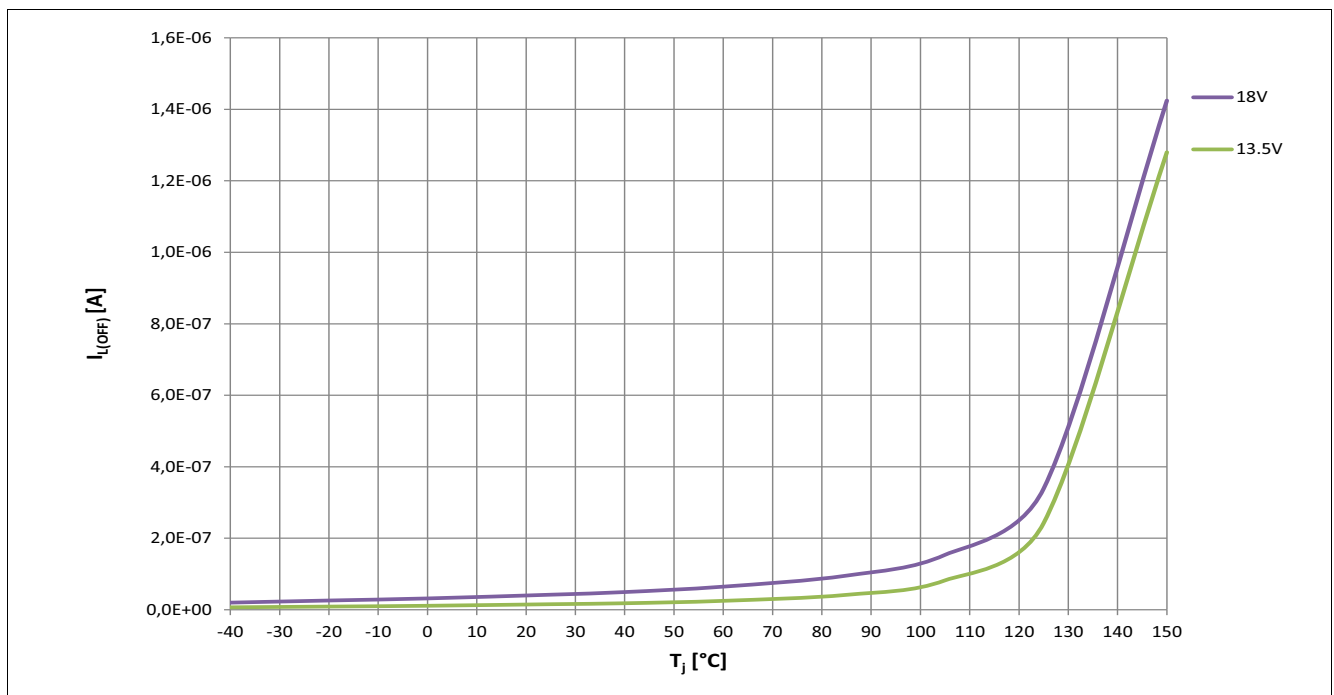

Figure 25 Typical  $I_{L(OFF)}$  vs.  $T_j$  @  $V_{IN} = 0V$ ,  $V_{BAT} = 13.5V$  and  $18V$

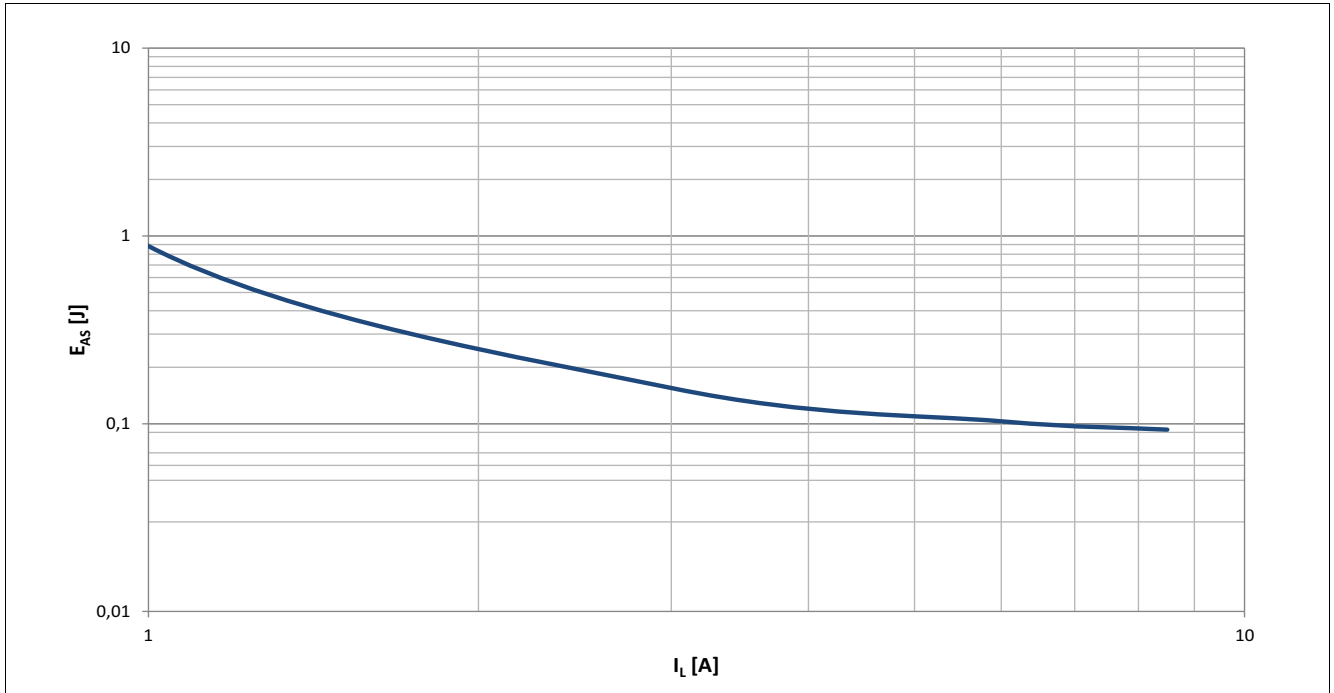

Figure 26 Maximum  $E_{AS}$  vs.  $I_L$  @  $T_j(0)=150^\circ\text{C}$ ,  $V_{BAT}=13.5\text{V}$

10.2 Dynamic characteristics:

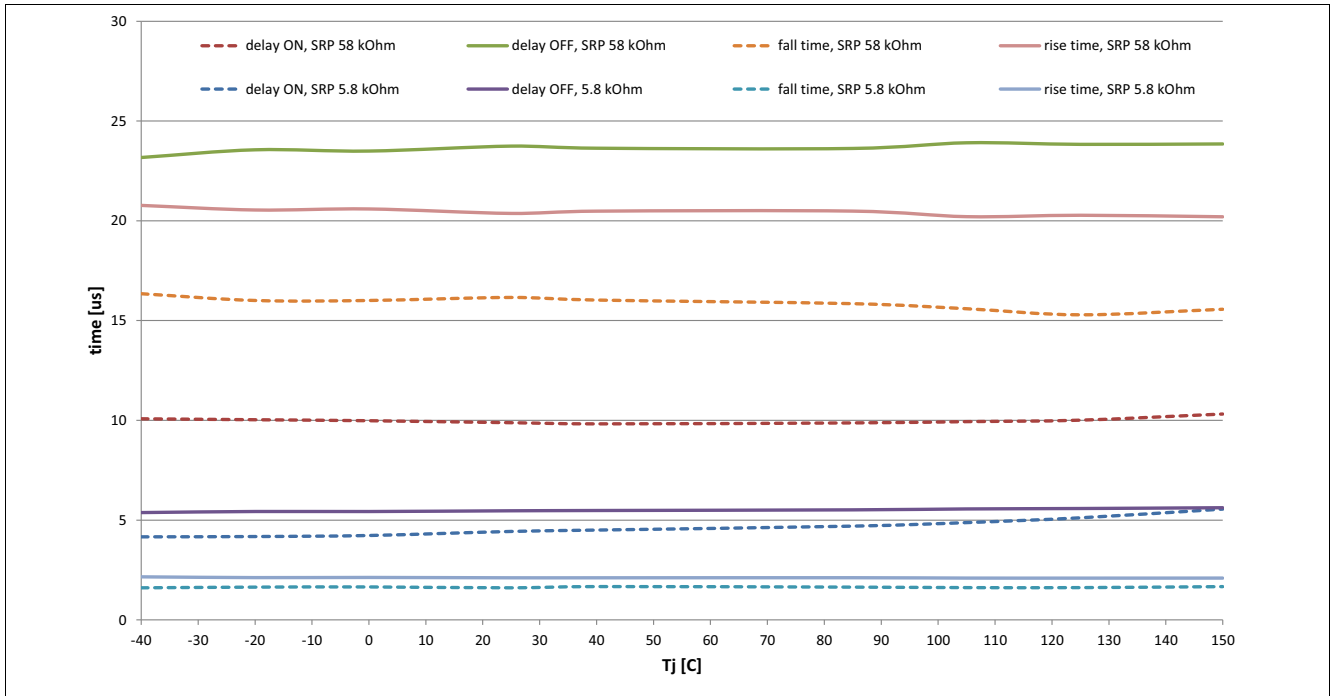

Figure 27 Typical fall time, rise time, delay on time, delay off time vs.  $T_j$  (-40..150°C) @  $R_{SRP}=5.8k\Omega$  and  $58k\Omega$   $V_{DD}=5V$ ,  $V_{BAT}=13.5$ ,  $V_{IN}=5V$

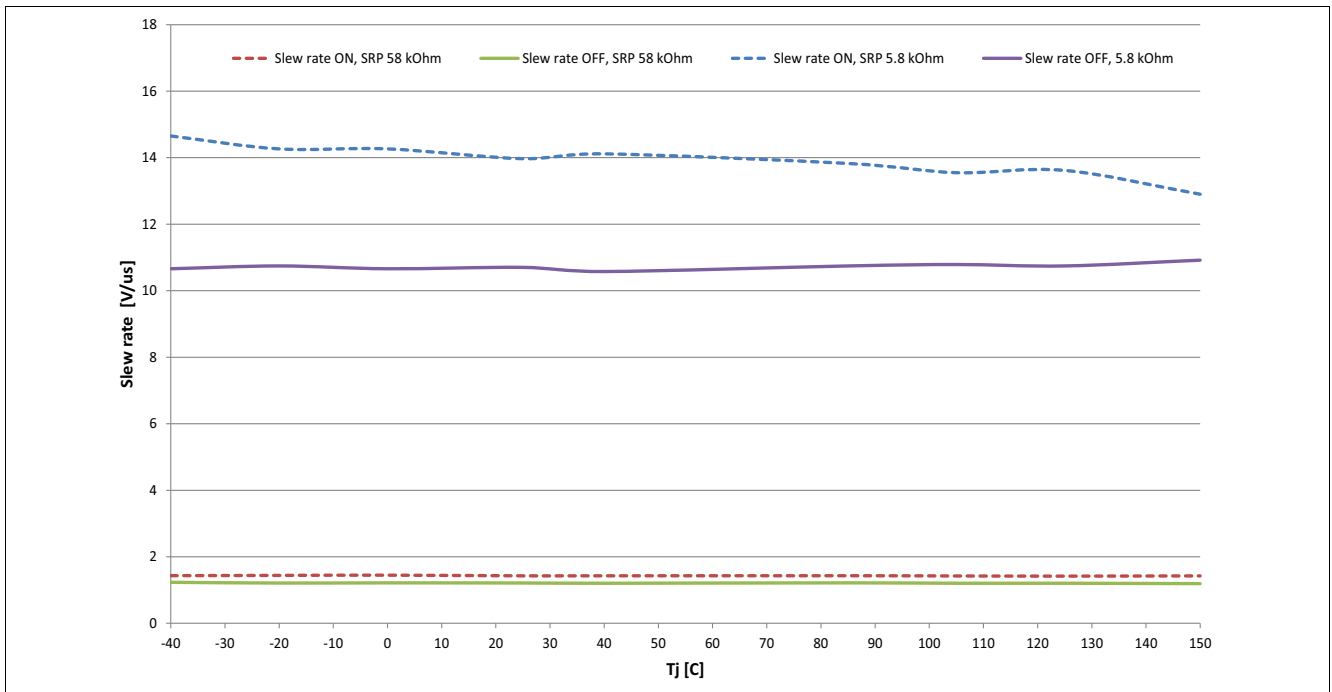

Figure 28 Typical slew rate vs.  $T_j$  (-40..150°C) @  $R_{SRP}=5.8k\Omega$  and  $58k\Omega$



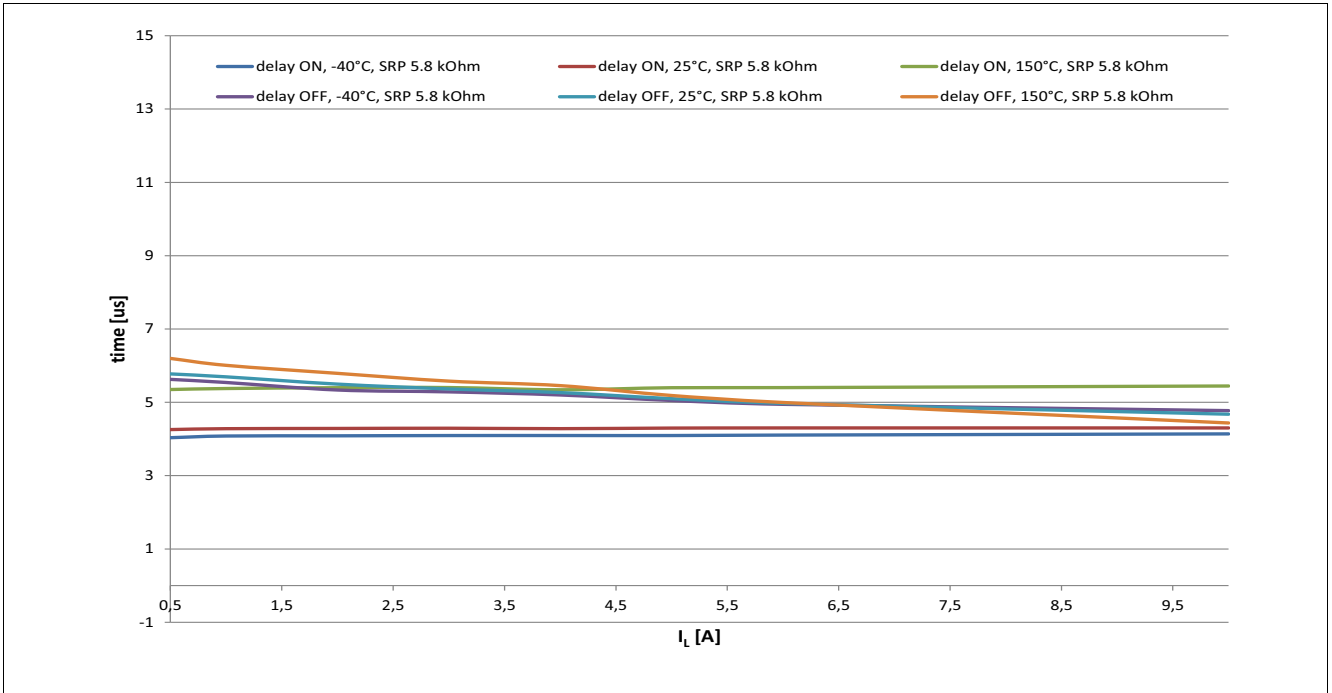

Figure 29 Typical delay on time, delay off time vs.  $I_L$  @  $T_j$  (-40..150°C)  $R_{SRP} = 5.8k\Omega$

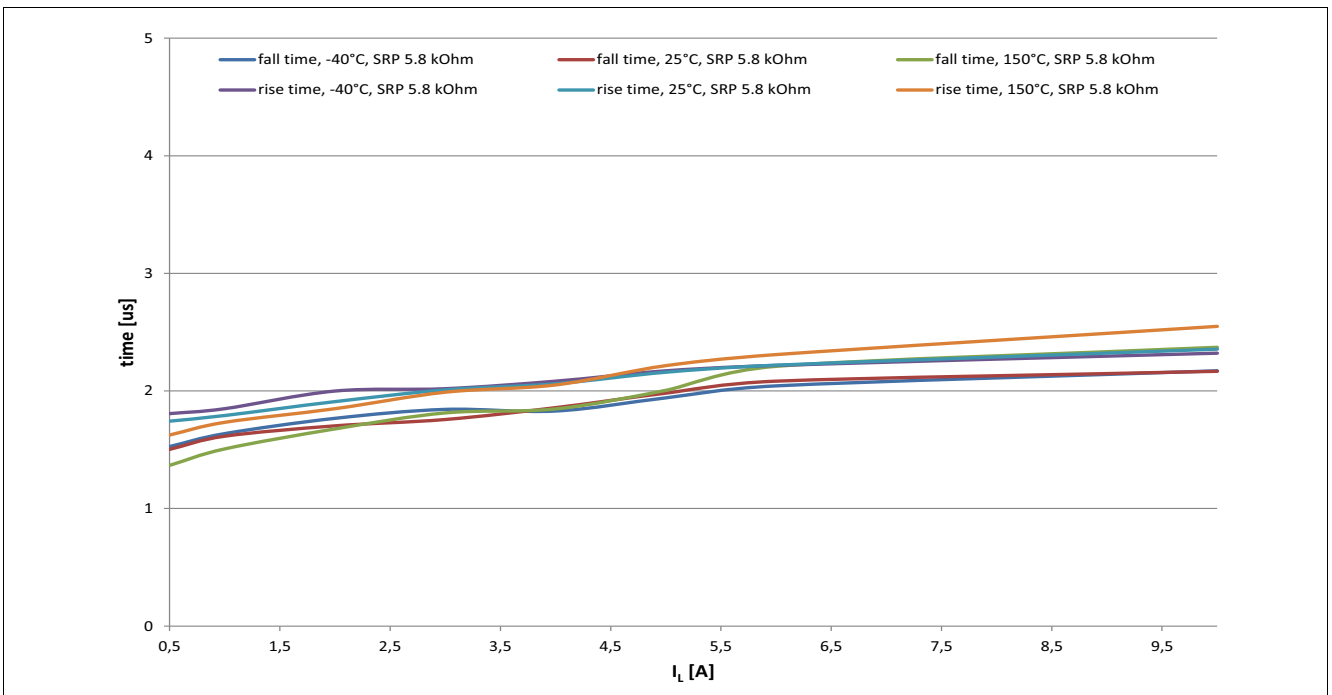

Figure 30 Typical fall time, rise time vs.  $I_L$  @  $T_j$  (-40..150°C)  $R_{SRP} = 5.8k\Omega$

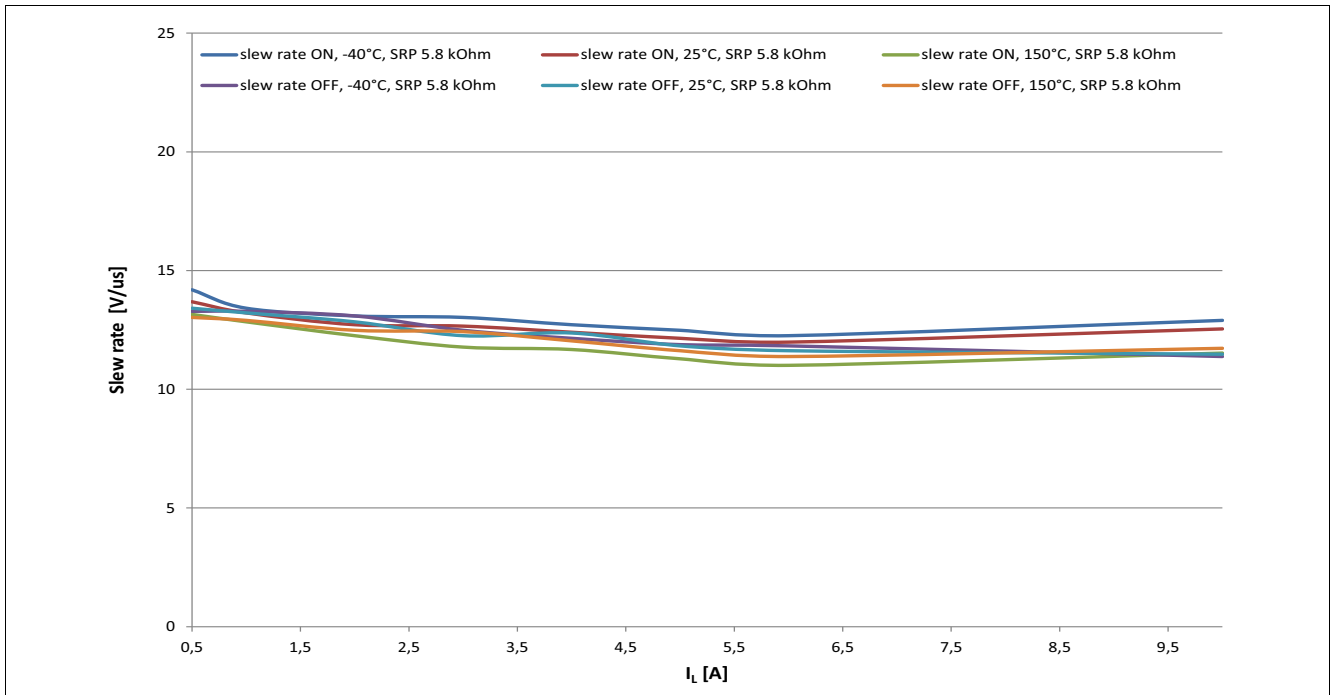

Figure 31 Typical slew rate vs.  $I_L$  @  $T_j$  (-40..150°C)  $R_{SRP}=5.8k\Omega$

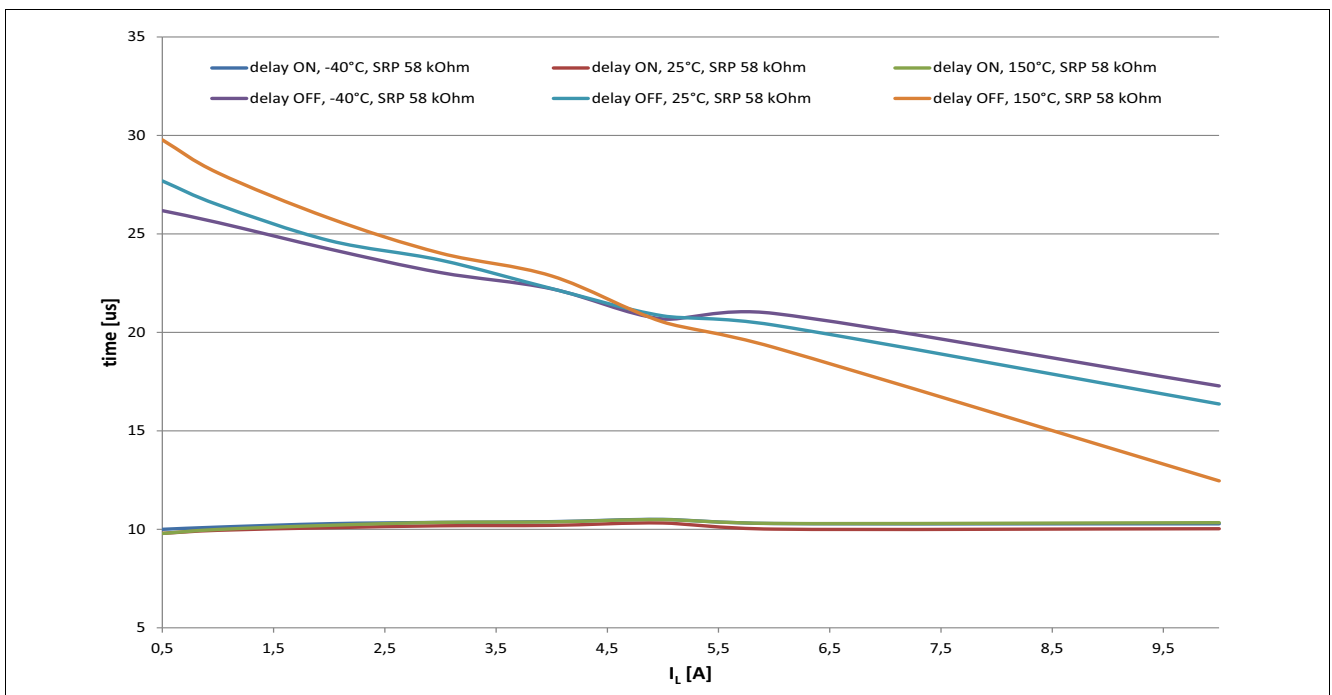

Figure 32 Typical delay on time, delay off time vs.  $I_L$  @  $T_j$  (-40..150°C)  $R_{SRP}=58k\Omega$

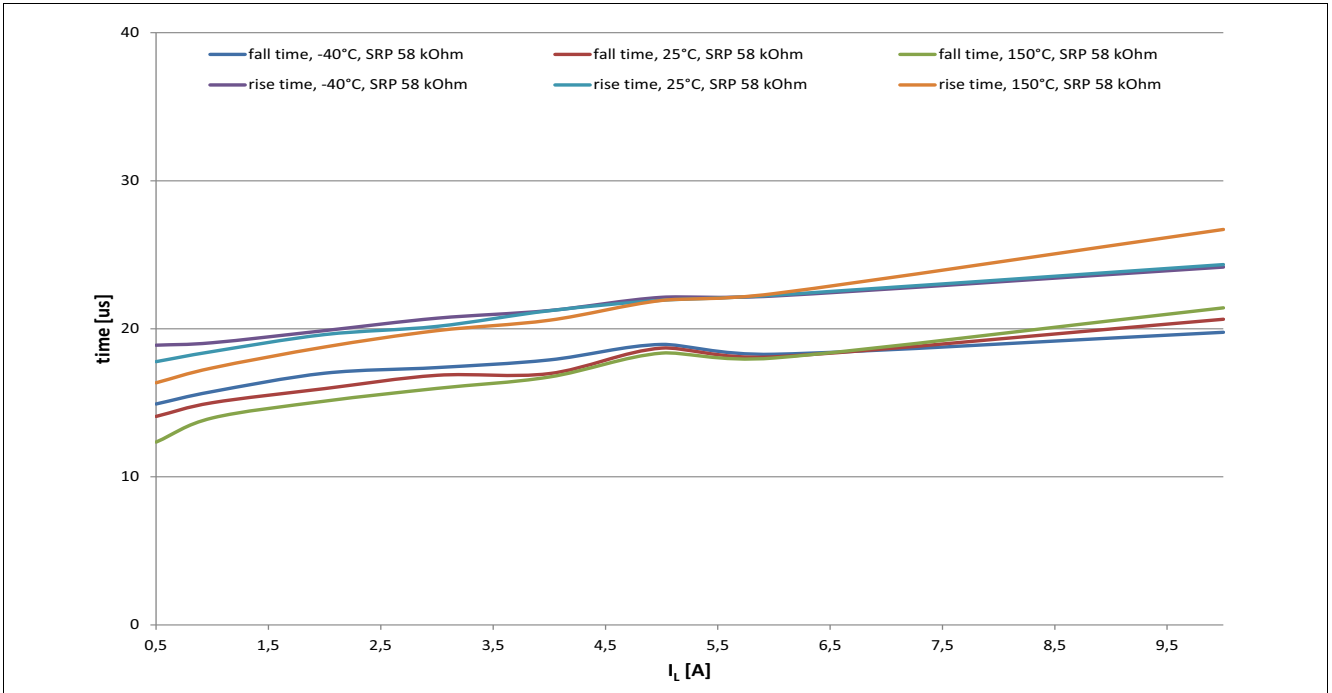

Figure 33 Typical rise time, fall time vs.  $I_L$  @  $T_j$  (-40..150°C)  $R_{SRP}=58\text{k}\Omega$

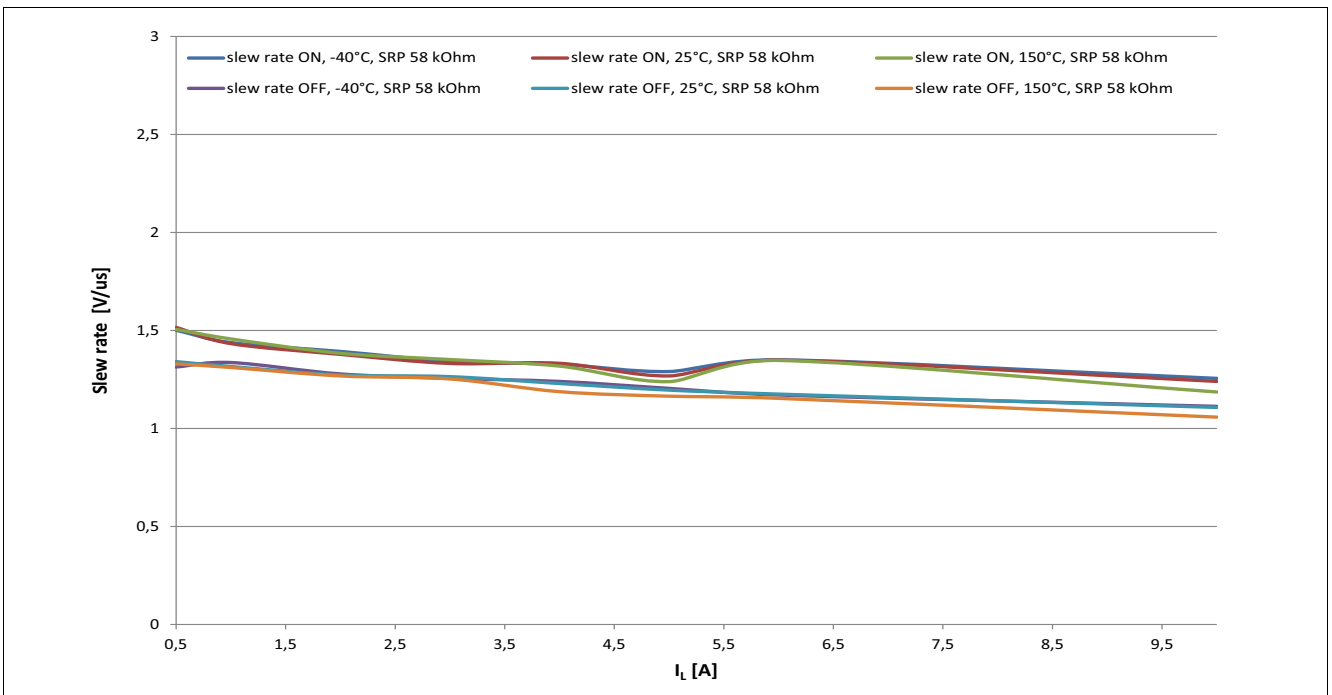

Figure 34 Typical slew rate vs.  $I_L$  @  $T_j$  (-40..150°C)  $R_{SRP}=58\text{k}\Omega$

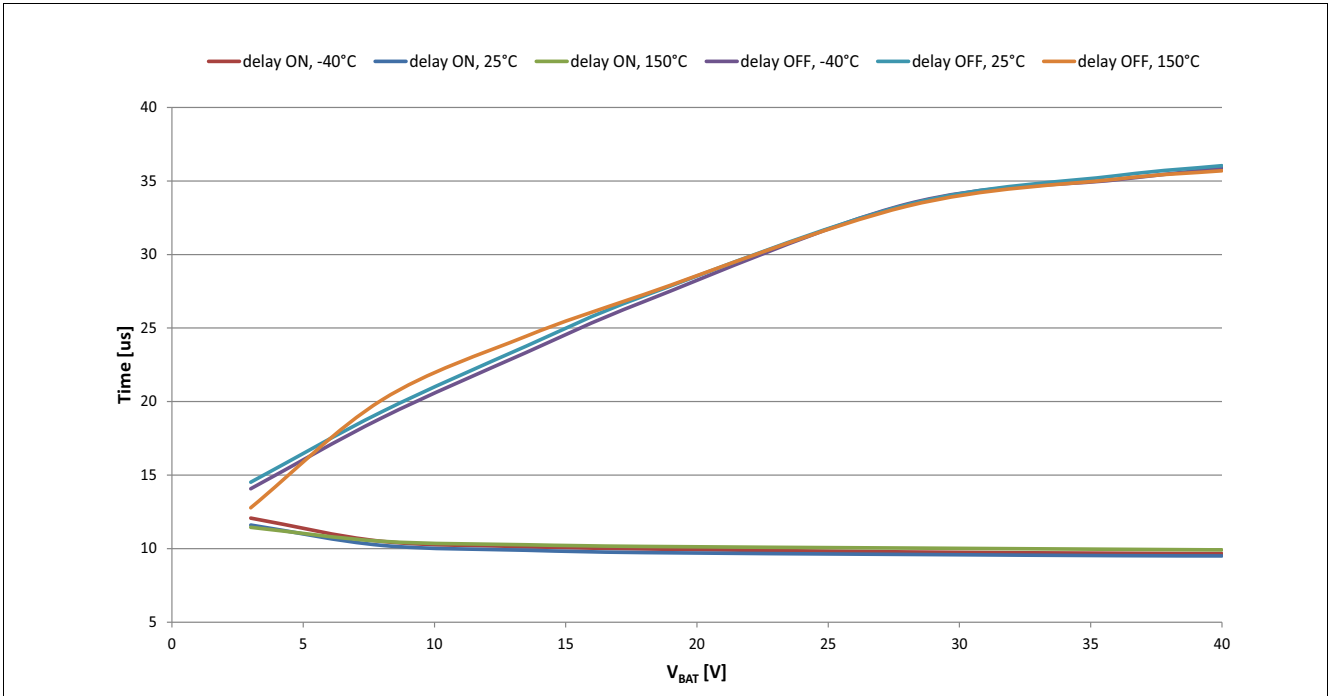

Figure 35 Typical delay on time, delay off time vs.  $V_{BAT}$  @  $T_j$  (-40..150°C),  $I_L=I_{(NOM)}$ ,  $R_{SRP}=58k\Omega$

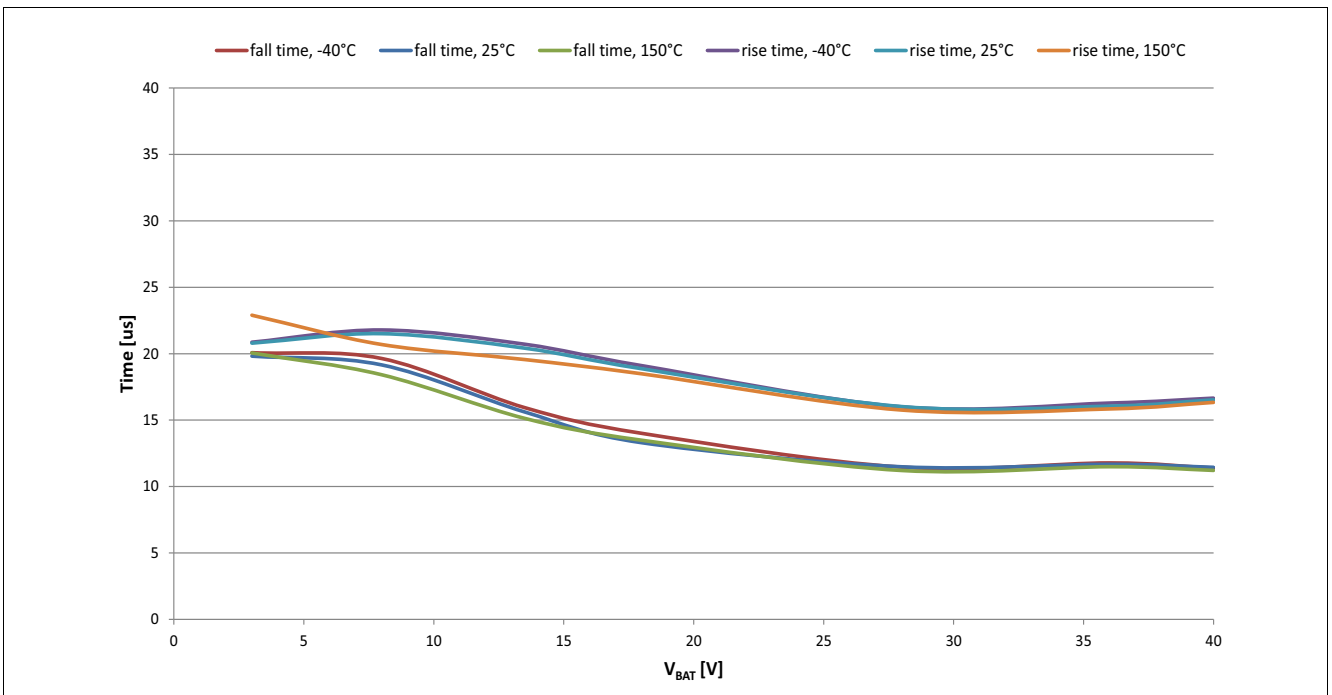

Figure 36 Typical rise time, fall time vs.  $V_{BAT}$  @  $T_j$  (-40..150°C),  $I_L=I_{(NOM)}$ ,  $R_{SRP}=58k\Omega$

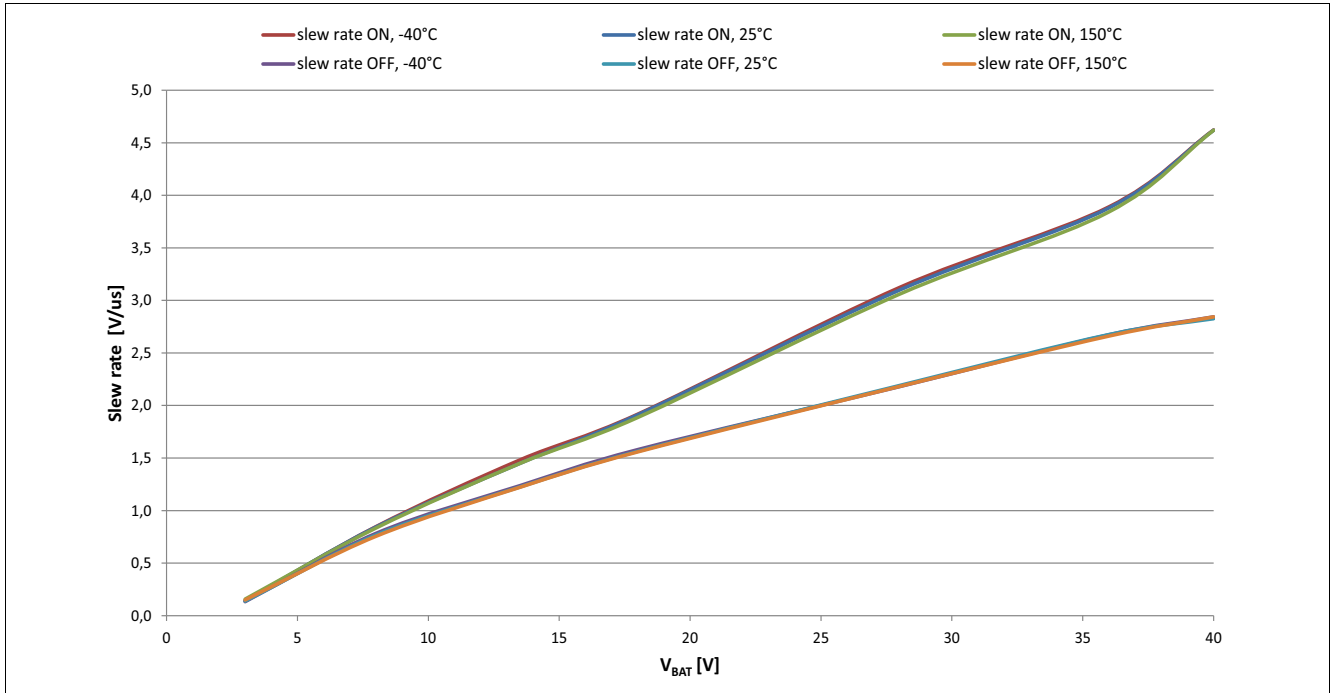

Figure 37 Typical slew rate vs.  $V_{BAT}$  @  $T_j$  (-40..150°C),  $I_L=I_{(NOM)}$ ,  $R_{SRP}=58k\Omega$

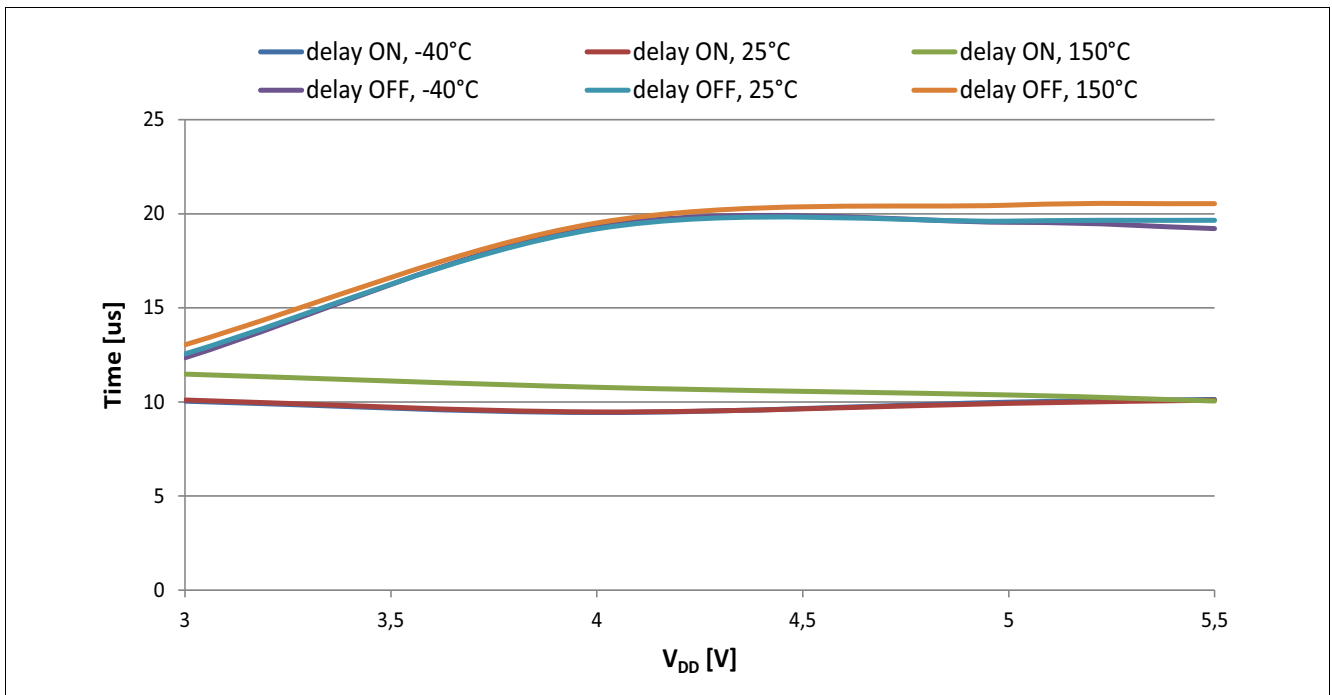

Figure 38 Typical delay on time, delay off time vs.  $V_{DD}$  @  $T_j$  (-40..150°C),  $R_L=4.5 \Omega$ ,  $R_{SRP}=58k\Omega$

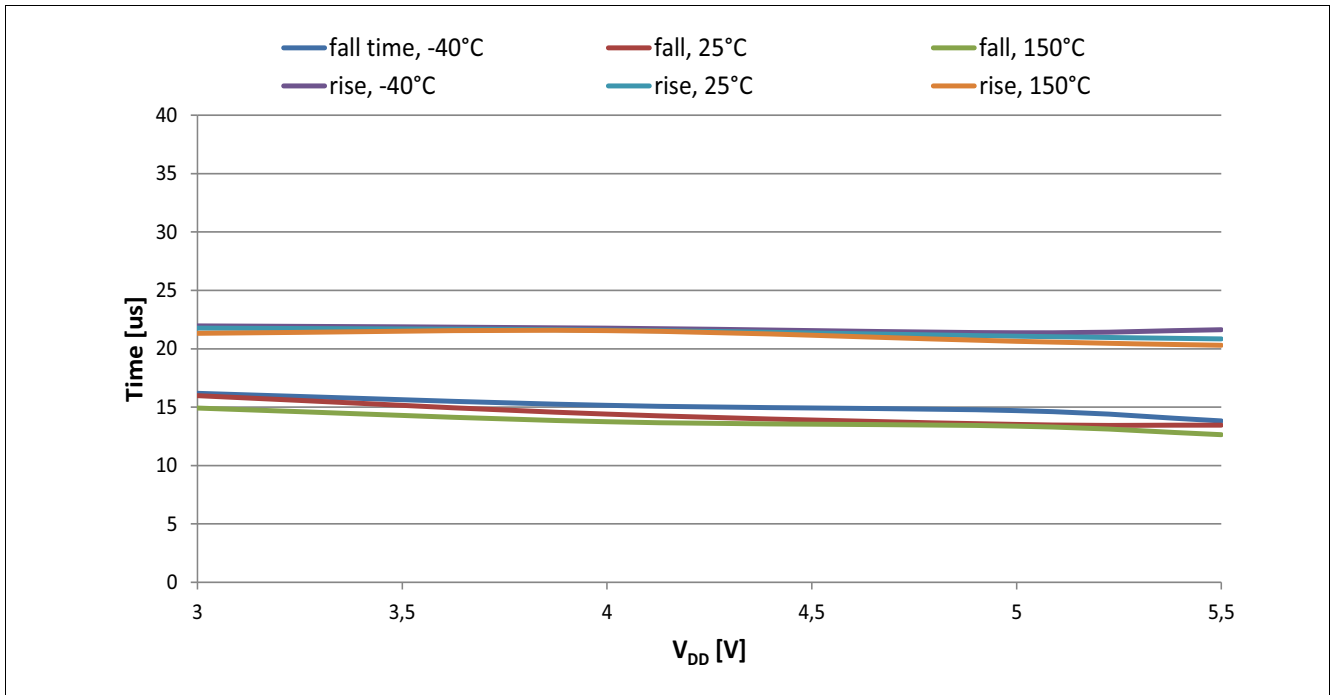

Figure 39 Typical rise time, fall time vs. V<sub>DD</sub> @ T<sub>j</sub> (-40..150°C), R<sub>L</sub>=4.5 Ω, R<sub>SRP</sub>=58kΩ

### 10.3 Protection

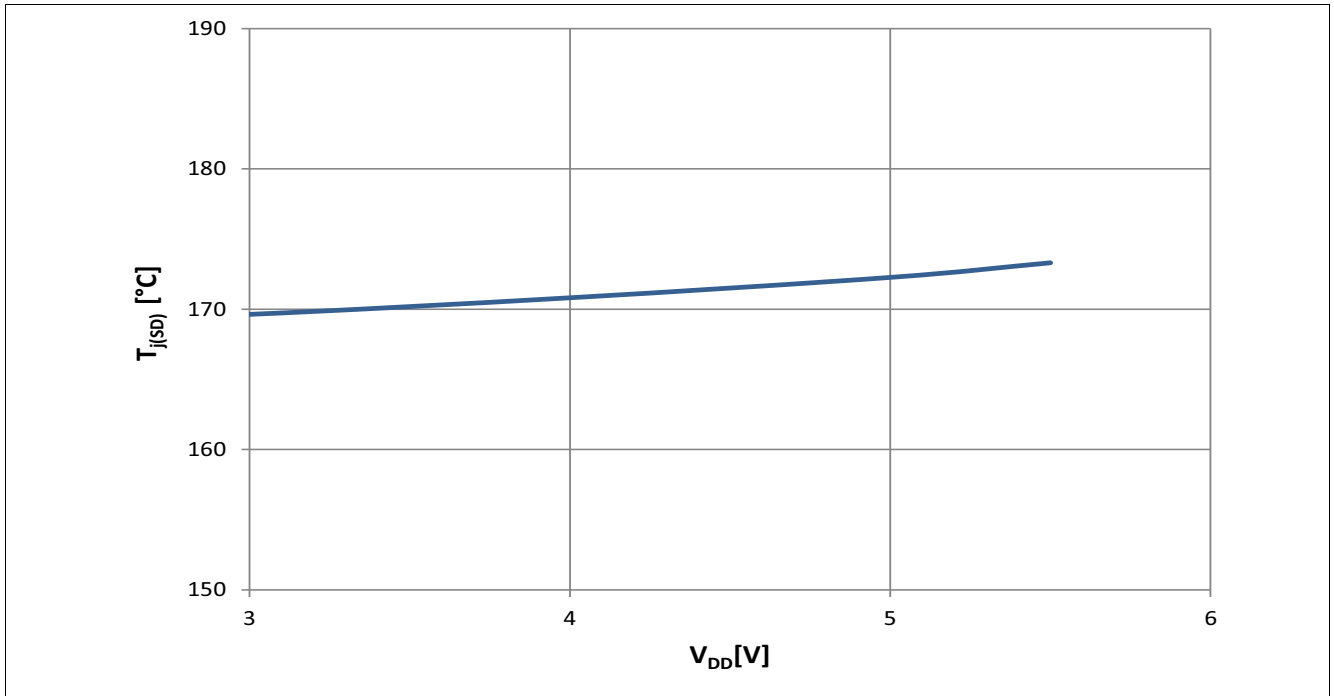

Figure 40 Typical  $T_{j(SD)}$  vs  $V_{DD}$  @  $I_L=10mA$

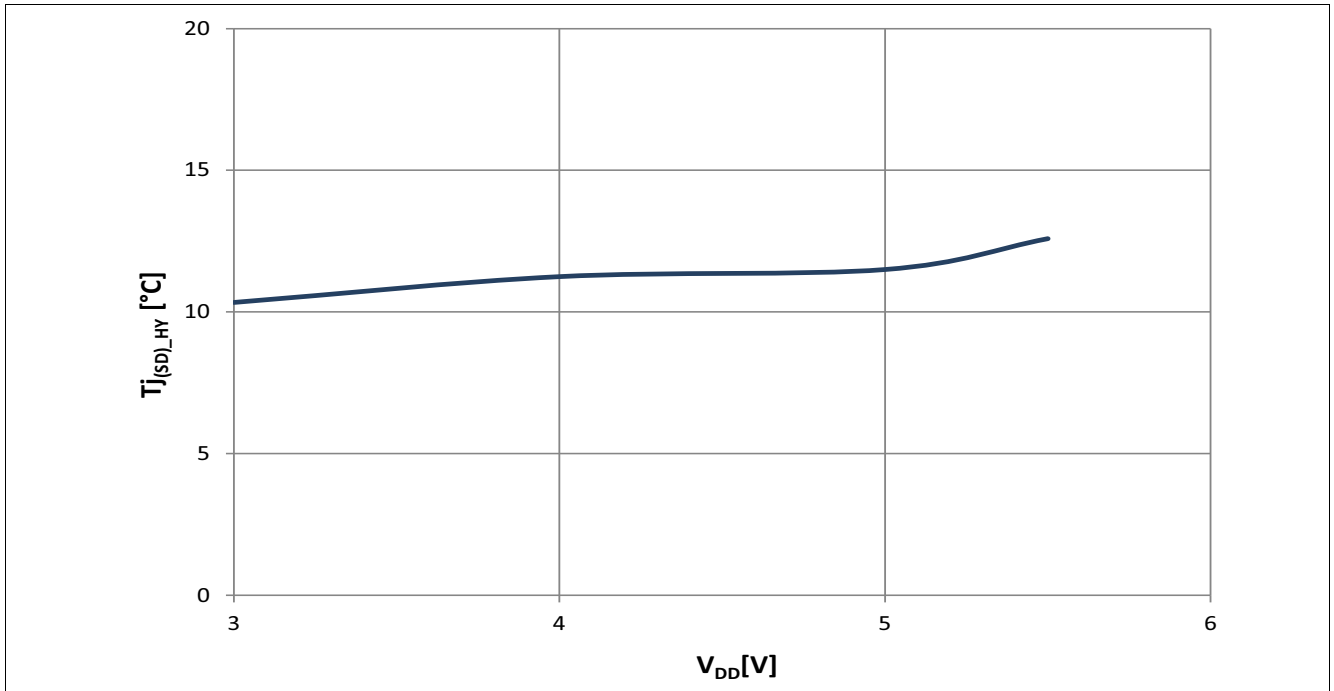

Figure 41 Typical  $T_{j(SD\_HYS)}$  vs  $V_{DD}$  @  $I_L=10mA$

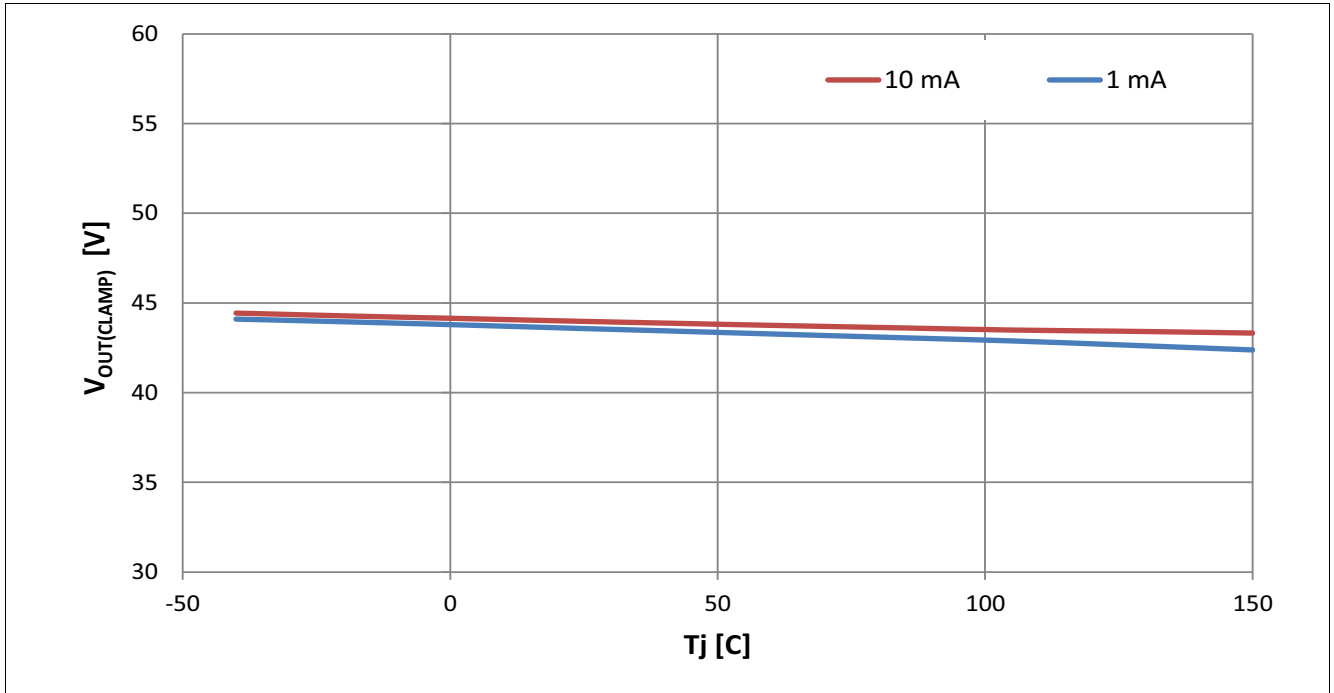

Figure 42 Typical V<sub>OUT(CLAMP)</sub> vs Tj

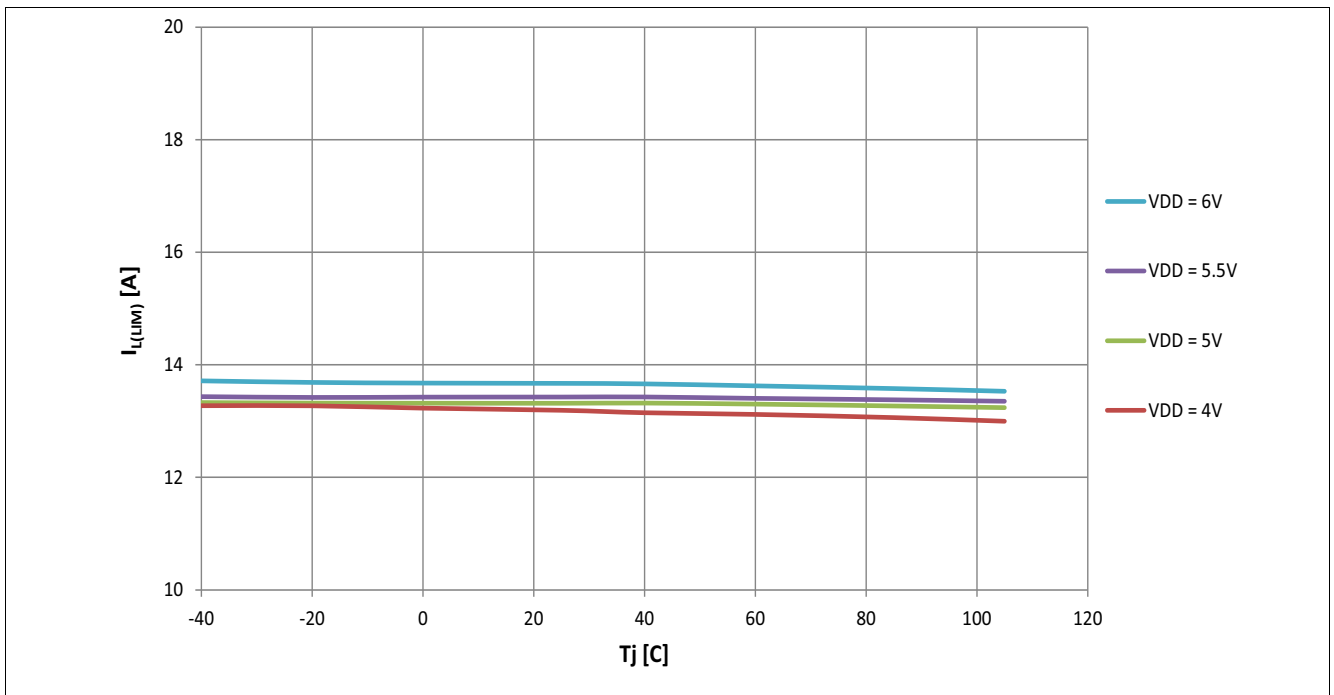

Figure 43 Typical I<sub>L(LIM)</sub> vs Tj @ V<sub>DD</sub>=4...6V



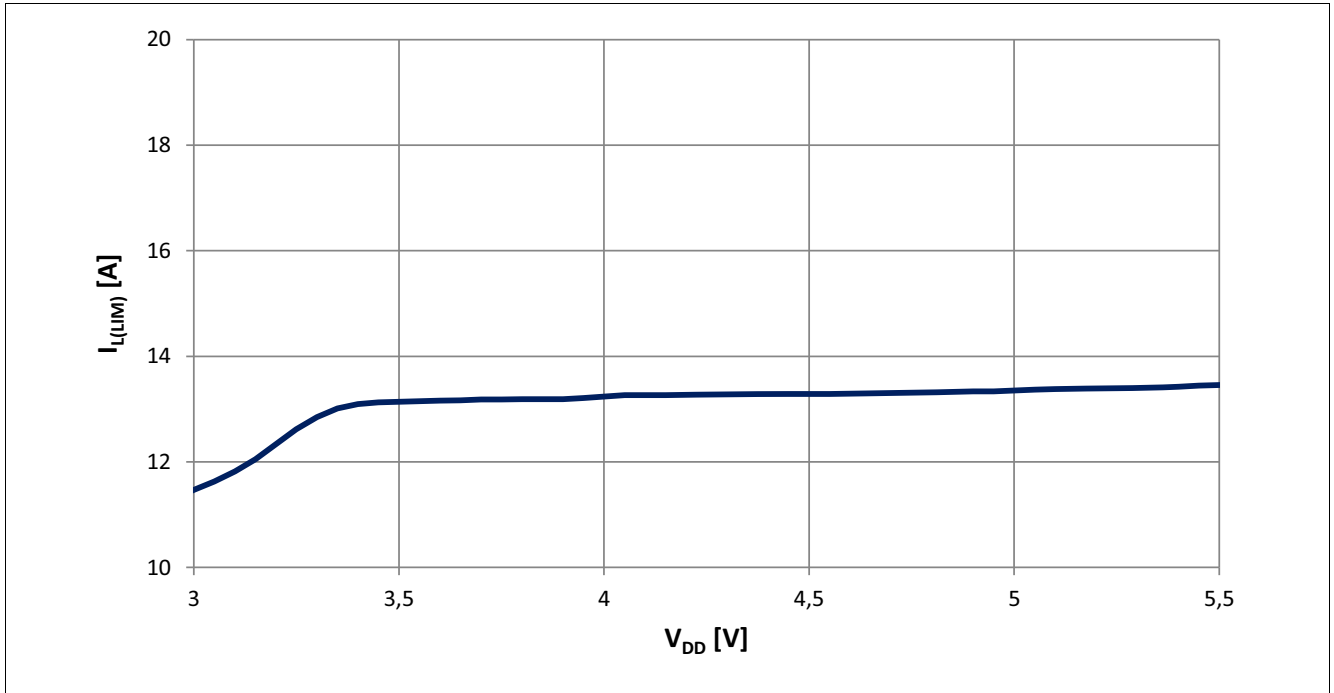

Figure 44 Typical  $I_{L(LIM)}$  vs.  $V_{DD}$  @  $T_j=25^\circ\text{C}$

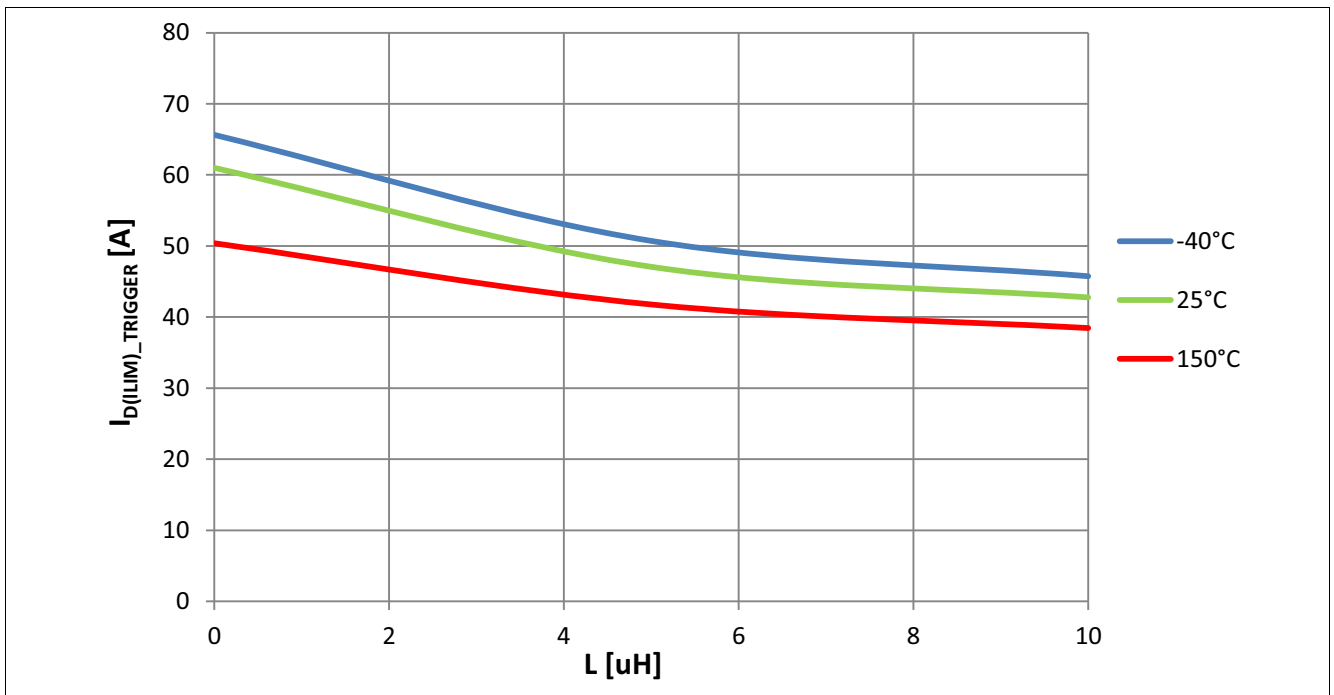

Figure 45 Typical  $I_{D(LIM)_TRIGGER}$  vs.  $L$  @  $T_j = (-40, 25, 150^\circ\text{C})$

### 10.4 Supply and Input Stage

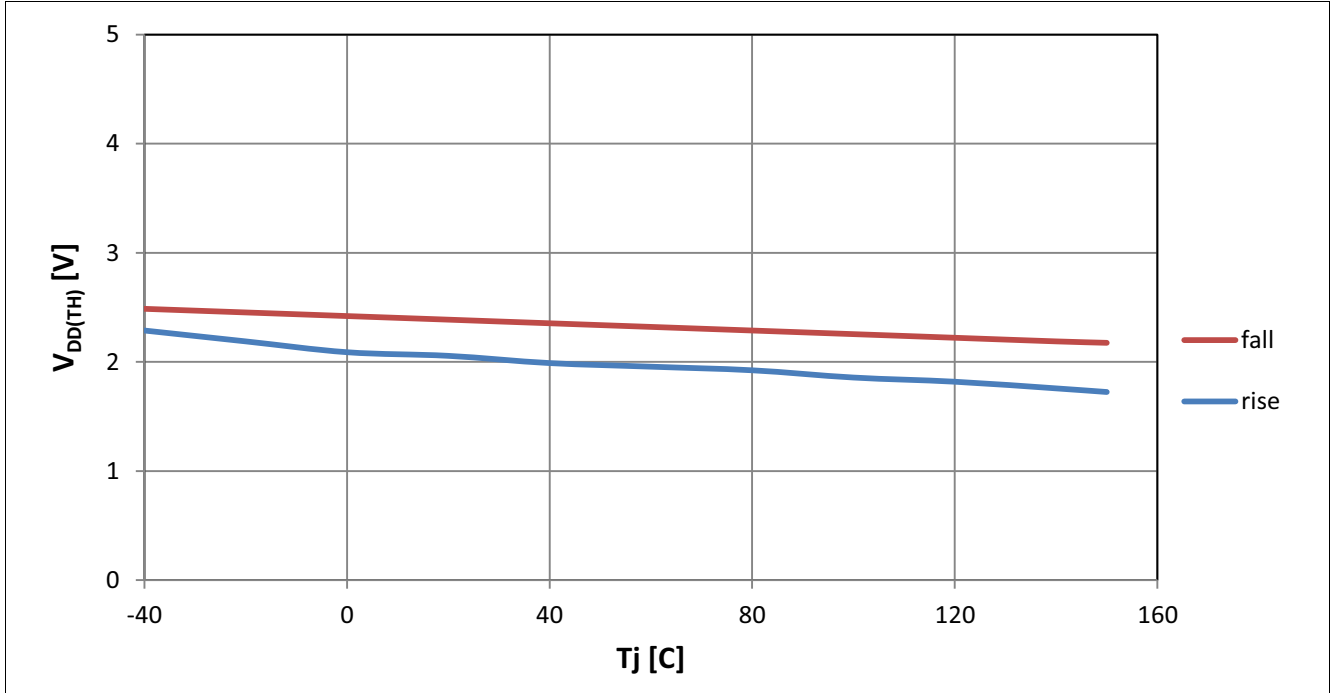

Figure 46 Typical  $V_{DD(TH)}$  vs  $T_j$  @  $R_L=4.5\Omega$

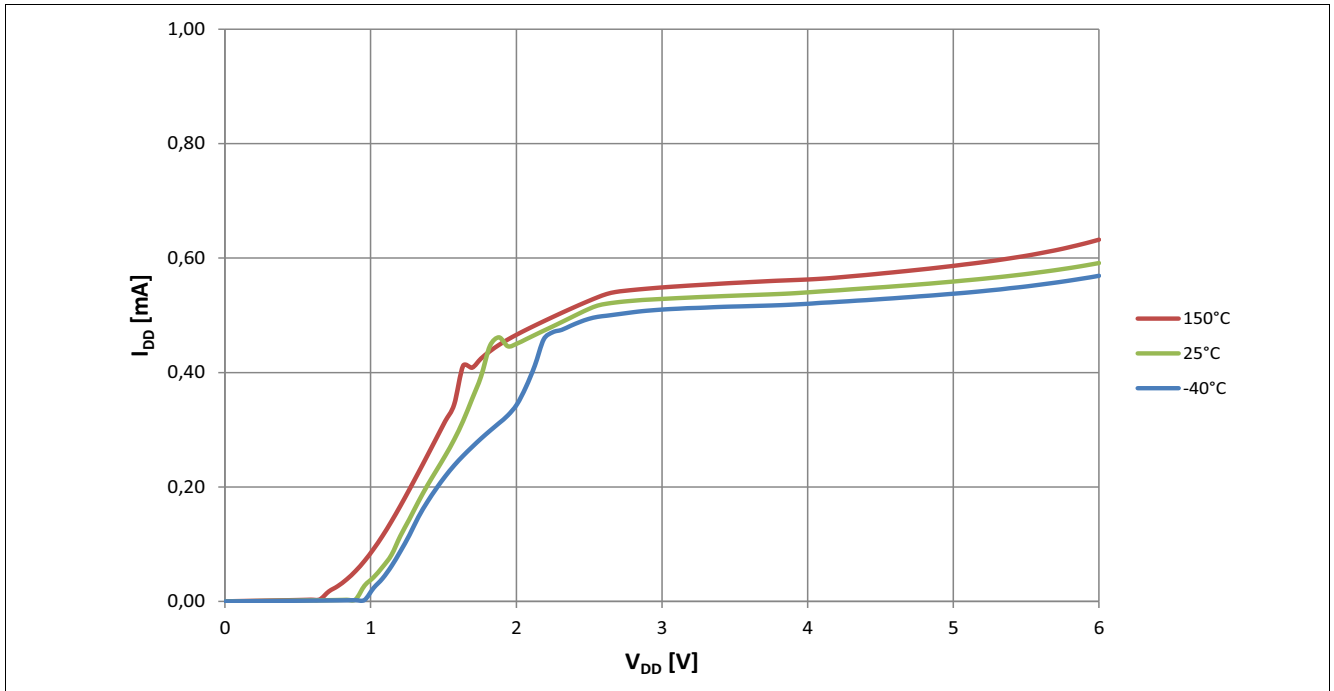

Figure 47 Typical  $I_{DD(ON)}$  vs.  $V_{DD}$  @  $T_j = (-40, 25, 150^\circ\text{C})$ ,  $V_{IN}=5\text{V}$

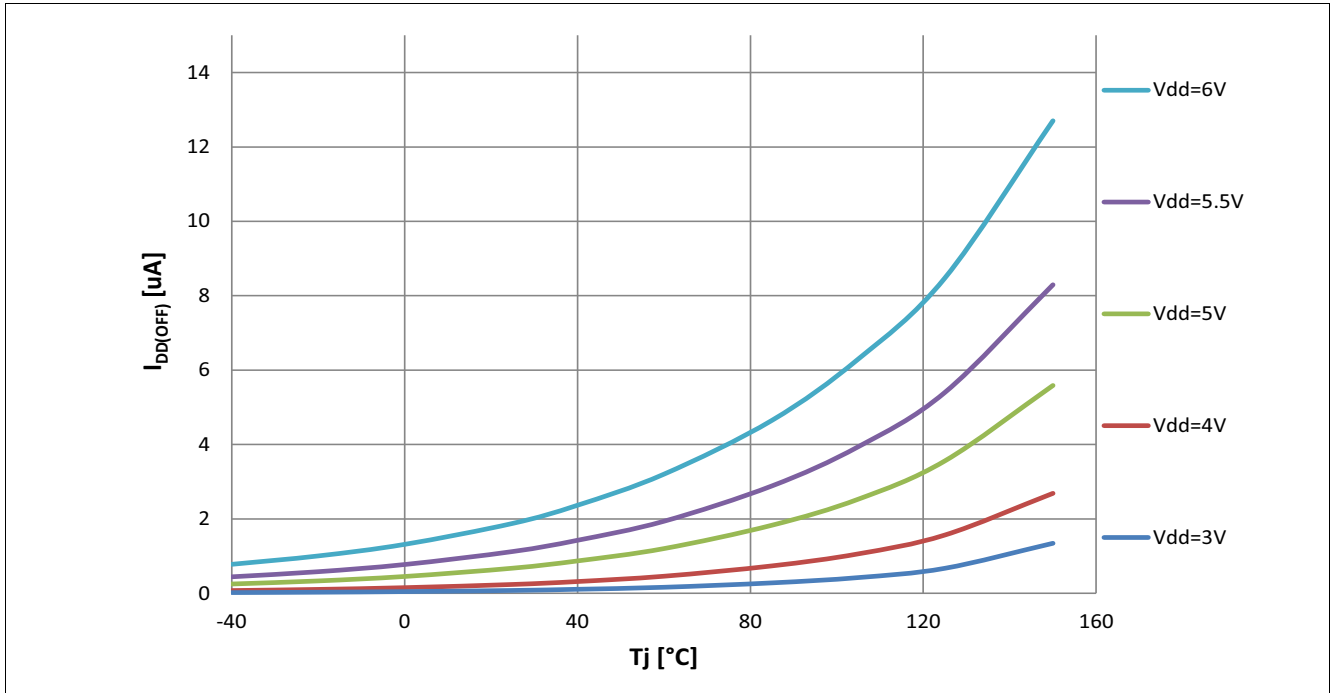

Figure 48 Typical  $I_{DD(OFF)}$  vs.  $T_j$  @  $V_{DD} = 3, 4, 5V, R_{RSP}=0\Omega$

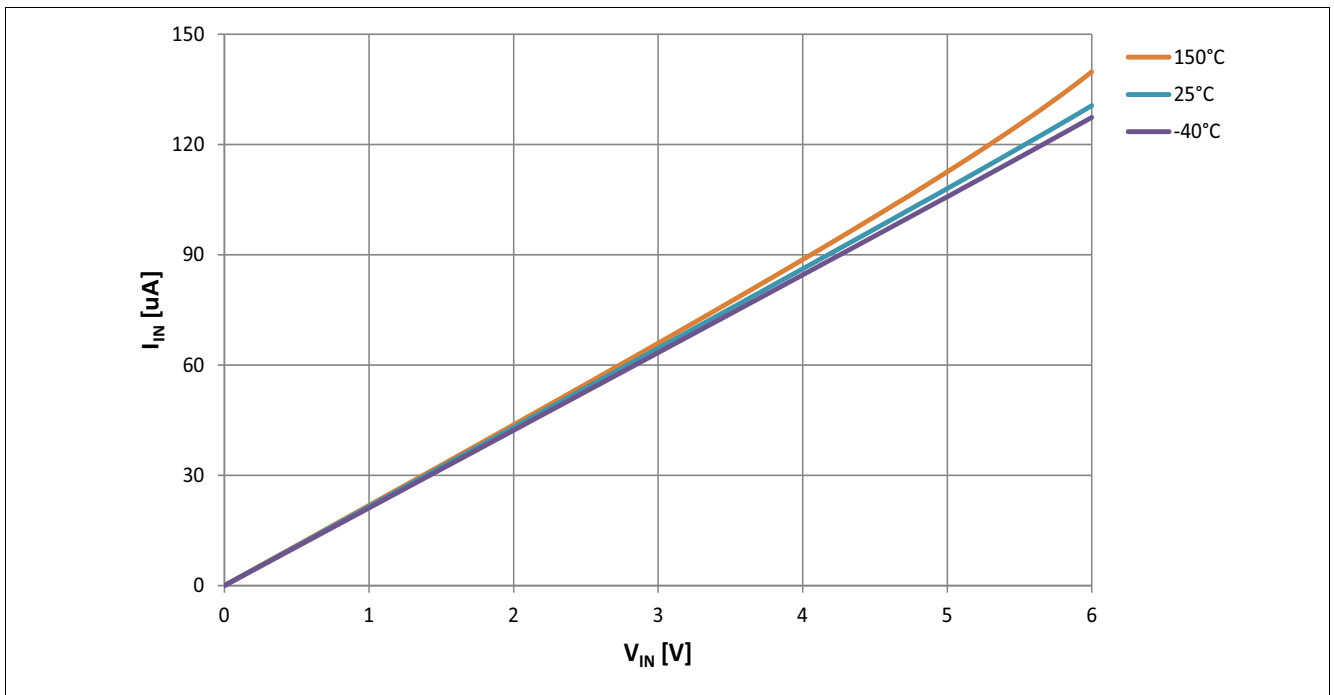

Figure 49 Typical  $I_{IN}$  vs.  $V_{IN}$  @  $T_j = (-40, 25, 150^\circ C)$

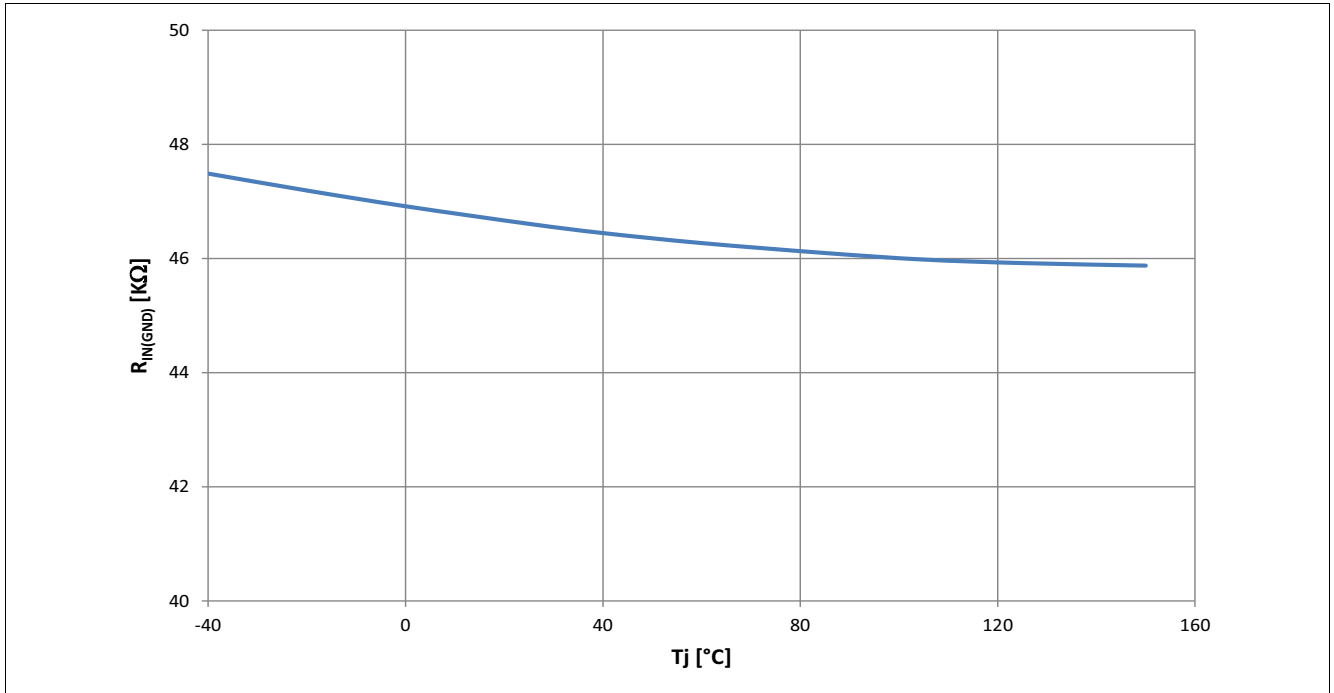

Figure 50 Typical  $R_{IN(GND)}$  vs.  $T_j$

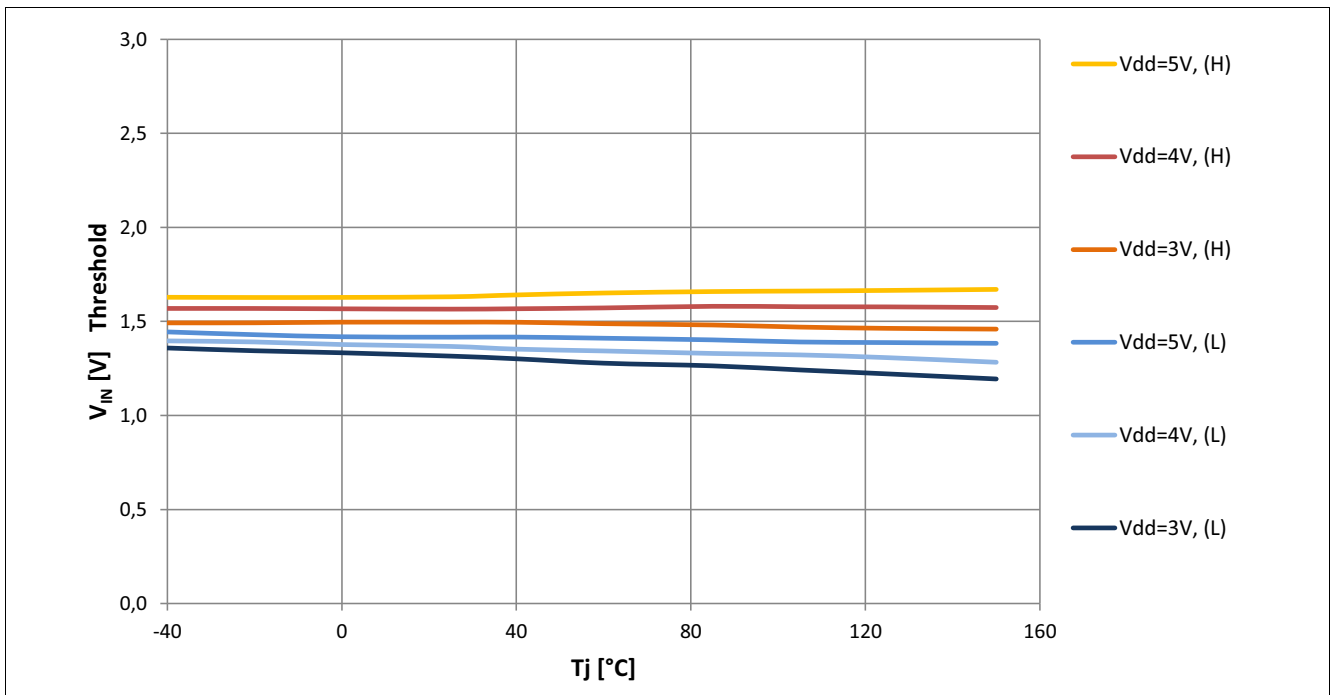

Figure 51 Typical  $V_{IN(TH)}$  vs.  $T_j$  @  $V_{DD} = 3V, 4V, 5V$

## 11 Application Information

Note: The following information is given as a hint for the implementation of the device only and shall not be regarded as a description or warranty of a certain functionality, condition or quality of the device.

### Application Diagram

An application example with the BTF3050TE is shown below.

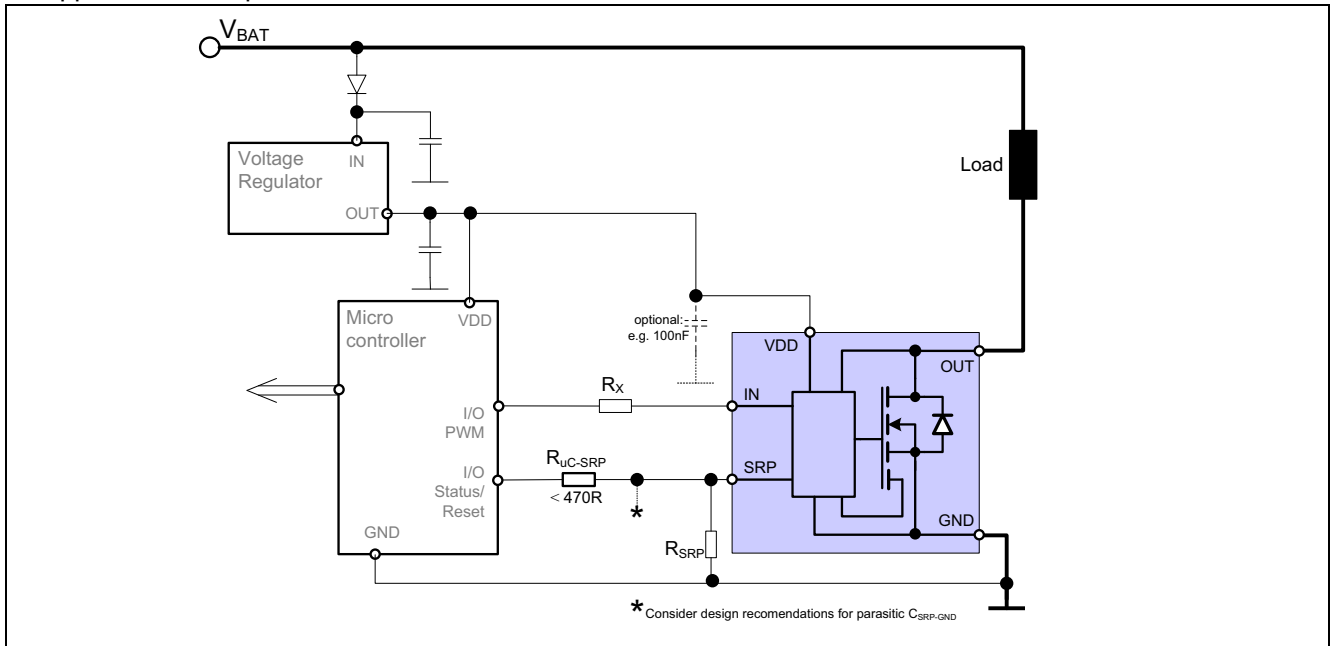

Figure 52 Simplified application diagram

Note: This is a very simplified example of an application circuit. The function must be verified in the real application.

### 11.1 Design and Layout Recommendations/Considerations

As consequence of the fast switching times for high currents, special care has to be taken to the PCB layout. Stray inductances have to be minimized. The BTF3050TE has no separate pin for power ground and logic ground. Therefore it is recommended to assure that the offset between the ground connection of the slew rate resistor and ground pin of the device (GND/SOURCE) is minimized. The resistor  $R_{SRP}$  should be placed near to the device and directly connected to the GND pin of the device to avoid any influence of GND shift to the functionality of the SRP pin.

In order to avoid influence on SRP functionality (e.g. switching times) the maximum parasitic capacitance between the SRP line and GND ( $C_{SRP-GND}$ ) has to be less than 100pF. It is strongly recommended to not let the SRP pin floating. A maximum resistor of 200 kohm to GND is recommended.

## 12 Package Outlines BTF3050TE

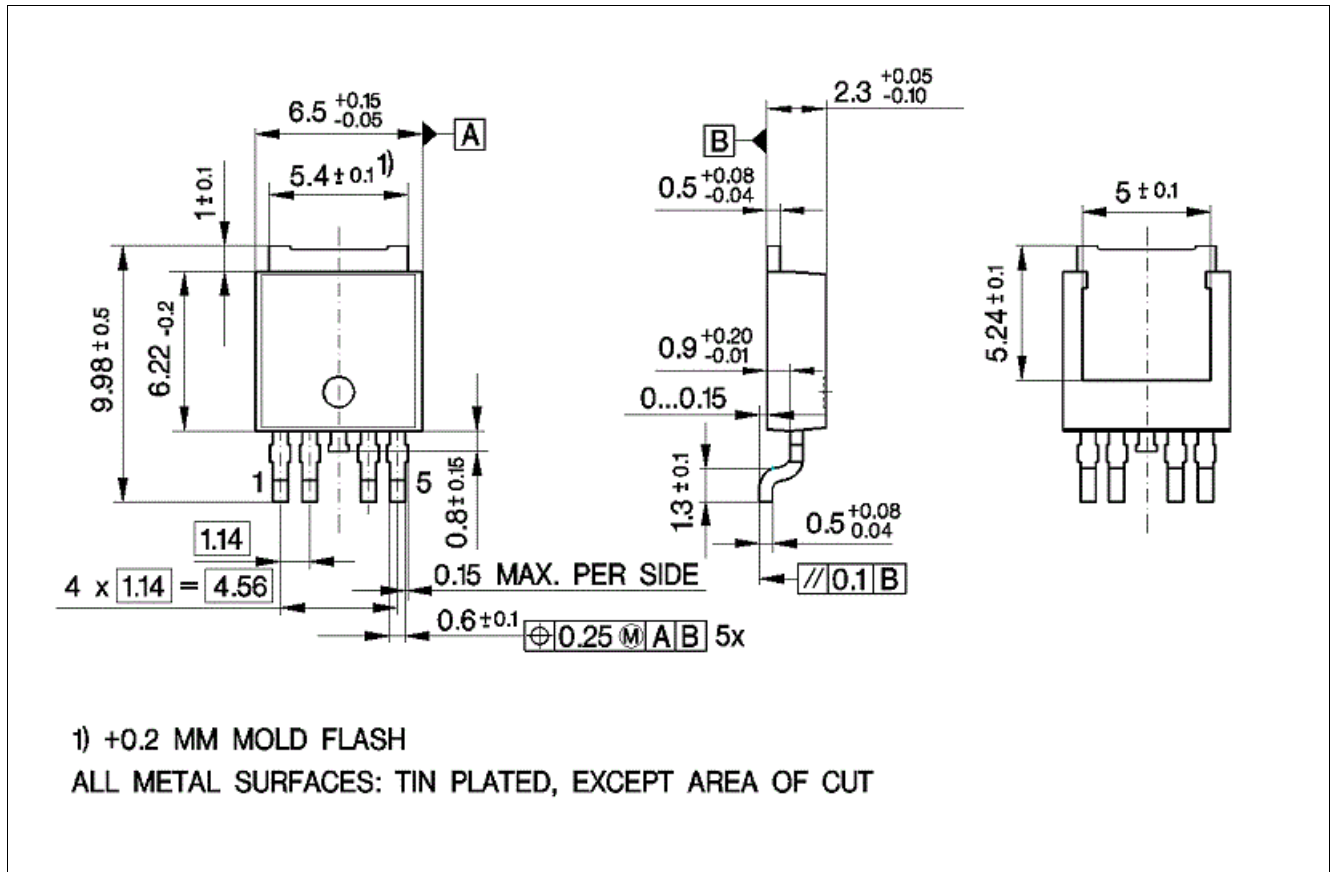

PG-TO252-5 (Transistor Outline Package)

### Green Product (RoHS compliant)

To meet the world-wide customer requirements for environmentally friendly products and to be compliant with government regulations the device is available as a green product. Green products are RoHS-Compliant (i.e. Pb-free finish on leads and suitable for Pb-free soldering according to IPC/JEDEC J-STD-020).

## 13 Revision History

Revision	Date	Changes
Rev. 1.1	2018-08-28	Figure 24. Typo corrected on “x” axis. $R_{DS(ON)}$ VS $V_{DD}$ Figure 25 and 26 duplicated. Figure 26 deleted Figure 49. remove 85°C from conditions Package Outlines corrected according to PG-TO252-5-11 dimensions Added $\Omega$ symbol for $R_{SRP}$ and $R_L$ unit in characterisation chapter Update front cover and back cover page templates
Rev. 1.0	2014-07-21	Datasheet released

## Trademarks

All referenced product or service names and trademarks are the property of their respective owners.

**Edition 2018-08-28**

**Published by**

**Infineon Technologies AG**

**81726 Munich, Germany**

**© 2018 Infineon Technologies AG.**

**All Rights Reserved.**

**Do you have a question about any aspect of this document?**

**Email: [erratum@infineon.com](mailto:erratum@infineon.com)**

**Document reference**

## IMPORTANT NOTICE

The information given in this document shall in no event be regarded as a guarantee of conditions or characteristics ("Beschaffenhheitsgarantie").

With respect to any examples, hints or any typical values stated herein and/or any information regarding the application of the product, Infineon Technologies hereby disclaims any and all warranties and liabilities of any kind, including without limitation warranties of non-infringement of intellectual property rights of any third party.

In addition, any information given in this document is subject to customer's compliance with its obligations stated in this document and any applicable legal requirements, norms and standards concerning customer's products and any use of the product of Infineon Technologies in customer's applications.

The data contained in this document is exclusively intended for technically trained staff. It is the responsibility of customer's technical departments to evaluate the suitability of the product for the intended application and the completeness of the product information given in this document with respect to such application.

For further information on technology, delivery terms and conditions and prices, please contact the nearest Infineon Technologies Office ([www.infineon.com](http://www.infineon.com)).

## WARNINGS

Due to technical requirements products may contain dangerous substances. For information on the types in question please contact your nearest Infineon Technologies office.

Except as otherwise explicitly approved by Infineon Technologies in a written document signed by authorized representatives of Infineon Technologies, Infineon Technologies' products may not be used in any applications where a failure of the product or any consequences of the use thereof can reasonably be expected to result in personal injury.



# Mouser Electronics

Authorized Distributor

Click to View Pricing, Inventory, Delivery & Lifecycle Information:

[Infineon:](#)

[BTF3050TEATMA1](#)

Компания «Life Electronics» занимается поставками электронных компонентов импортного и отечественного производства от производителей и со складов крупных дистрибьюторов Европы, Америки и Азии.

С конца 2013 года компания активно расширяет линейку поставок компонентов по направлению коаксиальный кабель, кварцевые генераторы и конденсаторы (керамические, пленочные, электролитические), за счёт заключения дистрибьюторских договоров

Мы предлагаем:

- Конкурентоспособные цены и скидки постоянным клиентам.
- Специальные условия для постоянных клиентов.
- Подбор аналогов.
- Поставку компонентов в любых объемах, удовлетворяющих вашим потребностям.
- Приемлемые сроки поставки, возможна ускоренная поставка.
- Доставку товара в любую точку России и стран СНГ.
- Комплексную поставку.
- Работу по проектам и поставку образцов.
- Формирование склада под заказчика.
- Сертификаты соответствия на поставляемую продукцию (по желанию клиента).
- Тестирование поставляемой продукции.
- Поставку компонентов, требующих военную и космическую приемку.
- Входной контроль качества.
- Наличие сертификата ISO.

В составе нашей компании организован Конструкторский отдел, призванный помогать разработчикам, и инженерам.

Конструкторский отдел помогает осуществить:

- Регистрацию проекта у производителя компонентов.
- Техническую поддержку проекта.
- Защиту от снятия компонента с производства.
- Оценку стоимости проекта по компонентам.
- Изготовление тестовой платы монтаж и пусконаладочные работы.



Тел: +7 (812) 336 43 04 (многоканальный)

Email: [org@lifeelectronics.ru](mailto:org@lifeelectronics.ru)