

Applications

- Automotive
- Instrumentation
- White goods
- Telecommunications

Benefits

- RoHS Compliant
- Halogen and Lead Free
- Sharp detection feeling
- Compact Size

JJ Series – Detector Switches

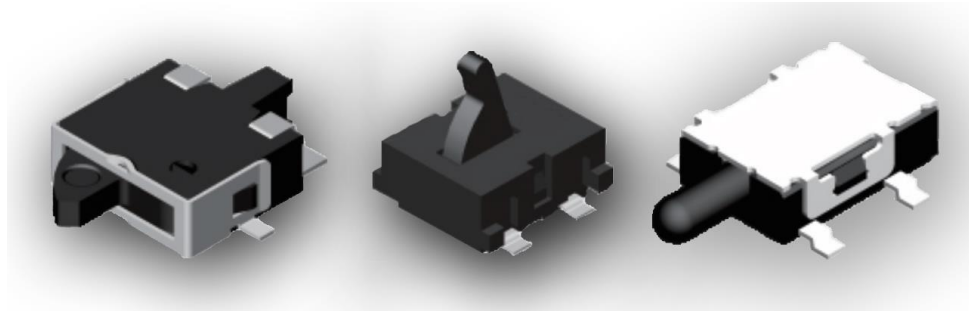

TE Connectivity is pleased to introduce its JJ Series of Detector Switches, suitable for a wide variety of applications given their several presentations ranging from horizontal or vertical actuated options as well as Gull-winged, J-leaded and Through-Hole mounting possibilities.

The Detector Switches will be offered in a wide range of sizes giving the possibility for countless applications going from automotive to telecommunications.

JJ Series – Family Classification

Series	Body Size
JJA	3.5x2.8 mm
JJB	3.5x2.98 mm
JJC	3.5x3.3 mm
JJD	4.2x3.6 mm
JJE	4.7x3.5 mm
JJF	4.7x3.8 mm
JJG	5.7x4.0 mm (Metal Cover)
JJH	5.7x4.0 mm (Plastic Cover)
JJI	5.0x4.4 mm
JJJ	6.0x4.85 mm / 5.5x4.7 mm
JJK	6.3x3.0 mm
JJL	6.5x3.9 mm
JJM	5.7x4.0 mm
JJN	5.7x4.0 mm (Wedge)
JJO	10.0x3.8 mm
JJP	10.6x10.0 mm

JJA Family – 3.5x2.8 mm

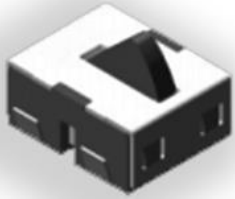
	Contact Rating	1mA, 5VDC
	Contact Resistance	2Ω Max.
	Insulation Resistance	100MΩ Min. 100VDC
	Dielectric Strength	100VAC/1 minute
	Operating Force	50gF max
	Travel	1.03mm
	Operating Life	100,000 cycles
	Operating Temperature	-10°C to 60°C
	Storage Temperature	-20°C to 70°C

Features	Applications
<ul style="list-style-type: none"> • Easy orientation offered by guiding post. • Ultra-low profile 	<ul style="list-style-type: none"> • Notebooks • Smart Phones

Circuit

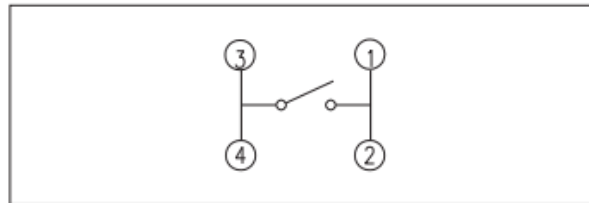

How To Order

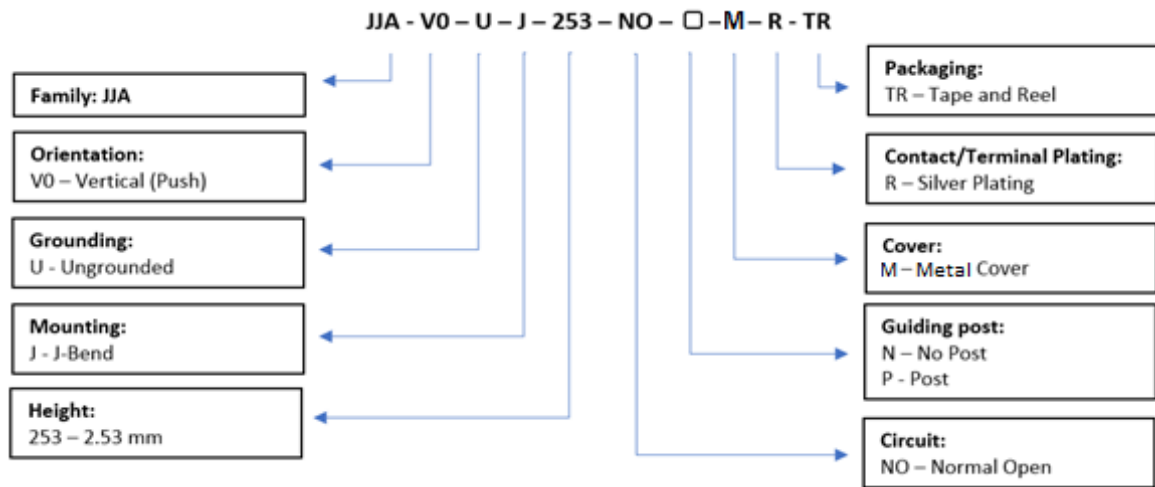

Diagrams

-Non-Posted

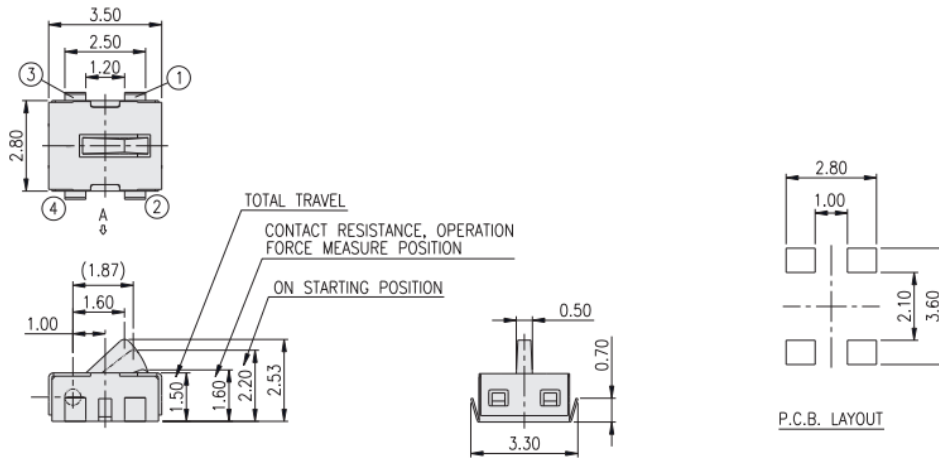

-Posted

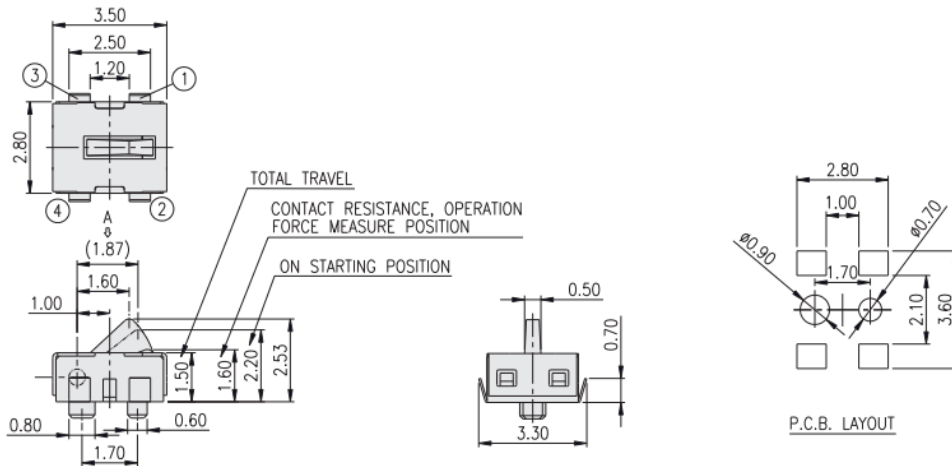

PN List

Smart PN	Orientation	Grounding	Mounting	Height	Circuit	Guiding Post	Cover	Plating	Packaging	MOQ	TE PN
JJAV0UJ253NOPMRTR	Vertical Push	Ungrounded	J-Bend	2.53mm	NO	Post	Metal	Silver	Tape and Reel	2,000	2331373-1
JJAV0UJ253NONMRTR	Vertical Push	Ungrounded	J-Bend	2.53mm	NO	No Post	Metal	Silver	Tape and Reel	2,000	2331374-1

1. Style

“Detector Switches” are mainly used as signal switches of electric devices, with the general requirements of mechanical and electrical characteristic.

1.1 Operating Temperature Range: -10°C to 60°C

1.2 Storage Temperature Range: -20°C to 70°C

1.3 The shelf life of product is within 6 months.

2. Current Range: 1mA, 5VDC

3. Type of Actuation: Momentary

4. Test Sequence:

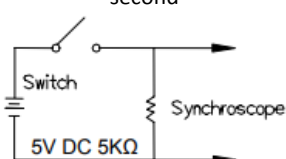
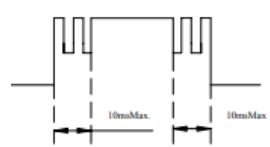
	Item	Description	Test Conditions	Requirements
Appearance	1	Visual Examination	Physical inspection without applying any external forces.	There shall be no defects that affect the serviceability of the product.
Electric Performance	2	Contact Resistance	Actuate the switch (1.60±0.2mm) and measure contact resistance using a micro-Ohmmeter.	2Ω Max.
	3	Insulation Resistance	Measurements shall be made at 100 VDC potential between terminals and cover.	100MΩ Min.
	4	Dielectric Withstanding Voltage	Apply 100 VAC (50Hz or 60Hz) between terminals and cover for 1 minute.	There shall be no breakdown or flashover
	5	Capacitance	Capacitance shall be measured at 1 MHz between terminals.	5 pF Max.
	6	Bounce	3 to 4 operations at a rate of 1 cycles per second 	10 m seconds Max. 



Mechanical Performance	7	Operating Force	Applying force to the center of the stem for 1.60±0.2mm (0.063 ± .008in.)	50gF Max. (0.49N Max.)
	8	Contact (On) point	-----	As the specification shows ON start position
	9	Stop Strength	Apply vertical static load of 500gF (4.90N) for 15 seconds and 100gF (0.98N) horizontal static load for 15 seconds.	1) As shown in item 4 to 5 2) Contact Resistance: 5Ω Max. 3) Insulation Resistance: 10MΩ Min.
	10	Solder Heat Resistance	(See chart below)	1) Shall be free from pronounced backlash and falling-off or breakage terminals 2) As shown in item 4 to 5 3) Contact Resistance: 5Ω Max. 4) Insulation Resistance: 10MΩ Min
	11	Vibration	Test per Method 201A of MIL-STD-202F 1) Swing distance=1.5mm 2) Frequency: 10-55-10Hz in 1-Min/cycle. 3) Direction: 3 vertical directions including the directions of operation 4) Test time: 2 hours each direction	1) As shown in item 4 to 5 2) Contact Resistance: 5Ω Max. 3) Insulation Resistance: 10MΩ Min
	12	Shock	Test per Method 213B condition A of MIL-STD-202F 1) Acceleration; 50G 2) Action time:11±1m seconds 3) Testing Direction: 6 sides 4) Test Cycle: 3 times in each direction	1) As shown in item 4 to 5 2) Contact Resistance: 5Ω Max. 3) Insulation Resistance: 10MΩ Min
Durability	13	Operating Life	Tested as follows: 1) 1mA,5 VDC resistive load 2) Applying a static load the operating force to the center of the stem in the direction of operation Static Load = OF Max. 3) Rate of Operation: 15 to 20 operations per minute. 4) Cycle of Operation: 100,000 cycles Min.	1) As shown in item 4 to 5 2) Operating force: Tolerance within +10% of initial force. 2) Contact Resistance: 5Ω Max. 3) Insulation Resistance: 10MΩ Min.

Water-Proof	14	Resistance Low Temperature	Following the test set forth below the sample shall be left in normal temperature and humidity conditions for 1 hour before the measurements are made: 1) Temperature: $-20\pm 2^{\circ}\text{C}$ 2) Time: 96 hours	1) As shown in item 4 to 5 2) Contact Resistance: 5Ω Max. 3) Insulation Resistance: $10\text{M}\Omega$ Min.
	15	Heat Resistance	Following the test set forth below the sample shall be left in normal temperature and humidity conditions for 1 hour before the measurements are made: 1) Temperature: $85\pm 2^{\circ}\text{C}$ 2) Time: 96 hours	1) As shown in item 4 to 5 2) Contact Resistance: 5Ω Max. 3) Insulation Resistance: $10\text{M}\Omega$ Min.
	16	Humidity Resistance	Following the test set forth below the sample shall be left in normal temperature and humidity conditions for 1 hour before the measurements are made: 1) Temperature: $40\pm 2^{\circ}\text{C}$ 2) Relative Humidity: 90 to 95% 3) Time: 96 hours	1) As shown in item 4 to 5 2) Contact Resistance: 5Ω Max. 3) Insulation Resistance: $10\text{M}\Omega$ Min.

5. Soldering Conditions:

■ Recommended Soldering Profile for the JJA Series

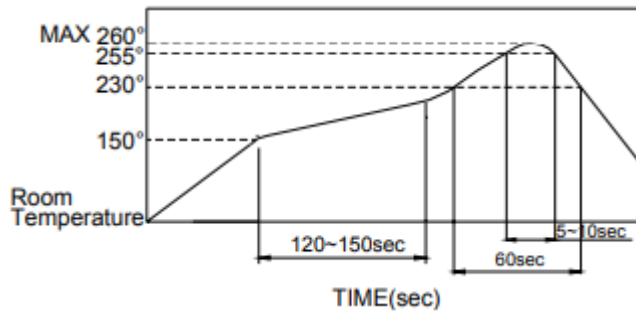

■ The temperatures defined above are the temperatures measured on the surface of the Printed Circuit Board. There are cases where the printed circuit board's temperature differs greatly from the temperature of the switch. Critical note: the switch's surface temperature must not exceed 260°C .

■ Manual Soldering

Soldering Temperature: 350°C Max.
Continuous Soldering Time: 5 second Max.

■ Precautions in Handling

- Care must be taken to ensure excess flux on the top surface of the printed circuit board does not adhere to the switch.
- Do not wash the switch.

■ Recommended storage conditions:

Store the products in the original packaging material. After opening the package, the remaining products must be stored in the appropriate moisture-proof & airtight environment.

Do not store the switch in the following environment or it may affect performance and solderability:

1. temperatures below -10° C to 40°C & humidity at 85% (min)
2. environment with corrosive gas
3. storage over 6 months
4. place in direct sunlight

Компания «Life Electronics» занимается поставками электронных компонентов импортного и отечественного производства от производителей и со складов крупных дистрибьюторов Европы, Америки и Азии.

С конца 2013 года компания активно расширяет линейку поставок компонентов по направлению коаксиальный кабель, кварцевые генераторы и конденсаторы (керамические, пленочные, электролитические), за счёт заключения дистрибьюторских договоров

Мы предлагаем:

- Конкуренспособные цены и скидки постоянным клиентам.
- Специальные условия для постоянных клиентов.
- Подбор аналогов.
- Поставку компонентов в любых объемах, удовлетворяющих вашим потребностям.
- Приемлемые сроки поставки, возможна ускоренная поставка.
- Доставку товара в любую точку России и стран СНГ.
- Комплексную поставку.
- Работу по проектам и поставку образцов.
- Формирование склада под заказчика.
- Сертификаты соответствия на поставляемую продукцию (по желанию клиента).
- Тестирование поставляемой продукции.
- Поставку компонентов, требующих военную и космическую приемку.
- Входной контроль качества.
- Наличие сертификата ISO.

В составе нашей компании организован Конструкторский отдел, призванный помогать разработчикам, и инженерам.

Конструкторский отдел помогает осуществить:

- Регистрацию проекта у производителя компонентов.
- Техническую поддержку проекта.
- Защиту от снятия компонента с производства.
- Оценку стоимости проекта по компонентам.
- Изготовление тестовой платы монтаж и пусконаладочные работы.



Тел: +7 (812) 336 43 04 (многоканальный)

Email: org@lifeelectronics.ru