

Automotive integrated H-bridge

Features

Type	$R_{DS(on)}$	I_{out}	V_{CCmax}
VNH7013XP-E	13 m Ω typ (per leg)	40 A	72 V ⁽¹⁾

1. Per leg: sum of the two BV_{dss} (HSD + LSD);
 $V_{CC} > 36$ V whole bridge must be switched off;

- Maximum V_{CC} voltage: 72 V
- 10 V compatible inputs
- $R_{DS(on)}$ per leg: 13 m Ω typical
- Embedded thermal sensor: -8.1 mV/ $^{\circ}$ K
- Very low stray inductance in power line



Description

The VNH7013XP-E is an automotive integrated H-bridge intended for a wide range of automotive applications driving DC motors. The device incorporates a dual channel and two single channel MOSFETs. All the devices are designed using STMicroelectronics[®] well known and proven proprietary VIPower[®] M0-S7 technology that allows to integrate in a package four different channels in H-bridge topology.

This package, specifically designed for the harsh automotive environment offers improved thermal performance thanks to exposed die pads. Moreover, its fully symmetrical mechanical design allows superior manufacturability at board level.

Table 1. Device summary

Package	Order codes	
	Tube	Tape and reel
PowerSSO-36 TP	VNH7013XP-E	VNH7013XPTR-E

Contents

- 1 Block diagram and pin description 5**

- 2 Electrical specifications 7**
 - 2.1 Absolute maximum rating 7
 - 2.2 Electrical characteristics 8

- 3 Package and PCB thermal data 15**
 - 3.1 PowerSSO-36 thermal data 15
 - 3.1.1 Thermal calculation in clockwise and anti-clockwise operation in steady-state mode 16
 - 3.1.2 Thermal resistances definition (values according to the PCB heatsink area) 17
 - 3.1.3 Thermal calculation in transient mode 17
 - 3.1.4 Single pulse thermal impedance definition (values according to the PCB heatsink area) 17

- 4 Package and packing information 20**
 - 4.1 ECOPACK® packages 20
 - 4.2 PowerSSO-36 TP package information 20
 - 4.3 PowerSSO-36 TP packing information 22

- 5 Revision history 23**



List of tables

Table 1.	Device summary	1
Table 2.	Pin definitions and functions	6
Table 3.	Absolute maximum rating	7
Table 4.	Power off.	8
Table 5.	Power on.	8
Table 6.	Dynamic	8
Table 7.	Gate resistance.	9
Table 8.	Source drain diode	9
Table 9.	Switching on HSD.	9
Table 10.	Switching on LSD	9
Table 11.	Switching off HSD.	9
Table 12.	Switching off LSD	10
Table 13.	Thermal sensor.	10
Table 14.	Thermal calculation in clockwise and anti-clockwise operation in steady-state mode	16
Table 15.	Thermal parameters	19
Table 16.	PowerSSO-36 TP mechanical data	21
Table 17.	Document revision history	23

List of figures

Figure 1.	Block diagram	5
Figure 2.	Configuration diagram	5
Figure 3.	Single pulse maximum current	7
Figure 4.	Gate charge vs gate-source voltage HS	10
Figure 5.	Gate charge vs gate-source voltage LS	11
Figure 6.	Capacitance variations HS	11
Figure 7.	Capacitance variations LS	12
Figure 8.	Thermal sensor voltage vs temperature	12
Figure 9.	Gate charge test circuit	13
Figure 10.	Test circuit for inductive load switching and diode recovery times	13
Figure 11.	Switching times test circuit for resistive load	14
Figure 12.	PowerSSO-36 PC board	15
Figure 13.	Chipset configuration	16
Figure 14.	Auto and mutual $R_{thj-amb}$ vs PCB copper area in open box free air condition	16
Figure 15.	PowerSSO-36 HSD thermal impedance junction ambient single pulse	18
Figure 16.	PowerSSO-36 LSD thermal impedance junction ambient single pulse	18
Figure 17.	Thermal fitting model of an H-bridge in PowerSSO-36	19
Figure 18.	PowerSSO-36 TP package dimensions	20
Figure 19.	PowerSSO-36 TP tube shipment (no suffix)	22
Figure 20.	PowerSSO-36 TP tape and reel shipment (suffix "TR")	22

1 Block diagram and pin description

Figure 1. Block diagram

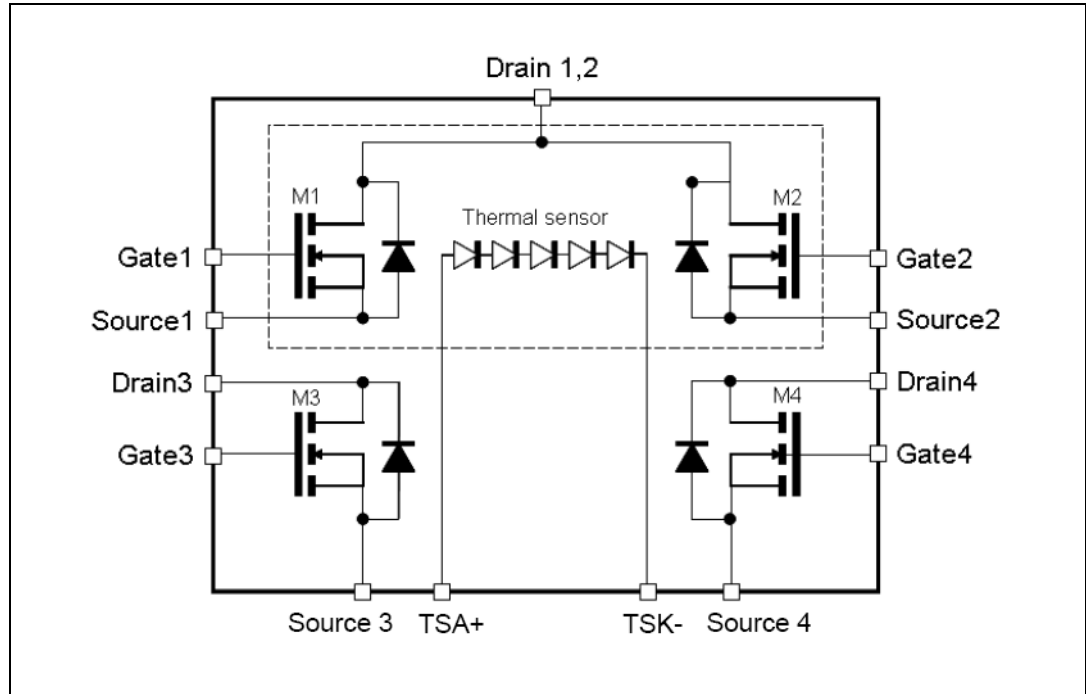

Figure 2. Configuration diagram

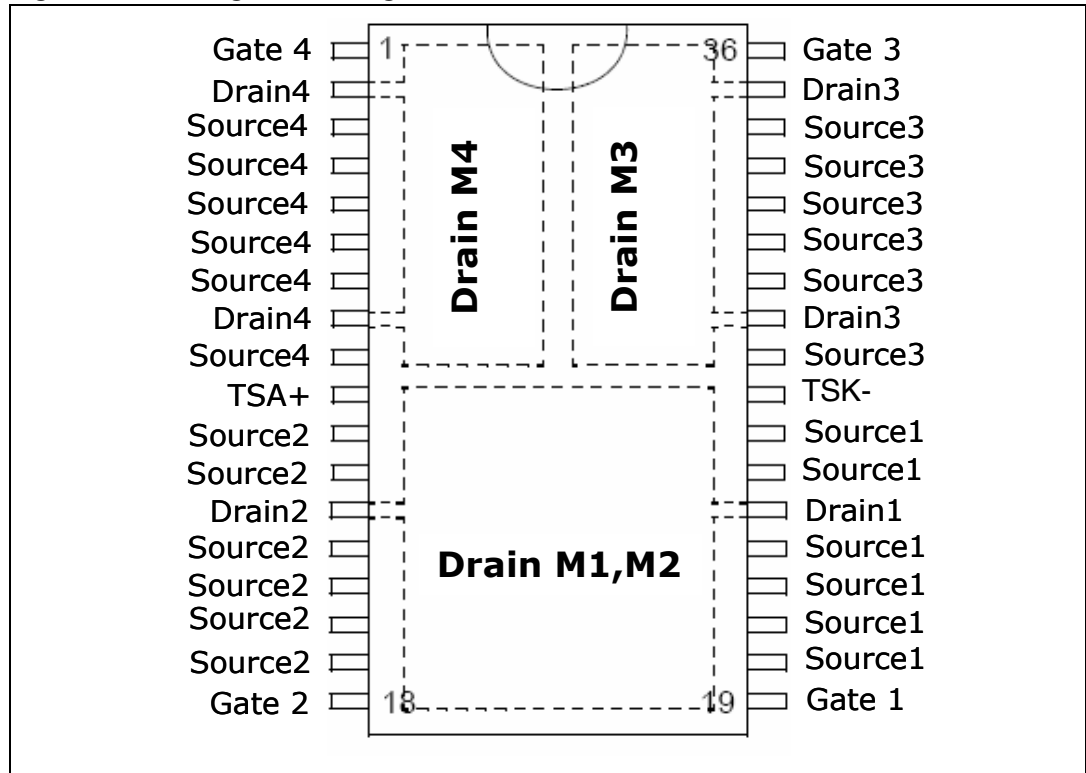

Table 2. Pin definitions and functions

Pin number	Symbol	Function
1	Gate 4	Gate of the LSD 4
2, 8	Drain 4	Drain of the LSD 4
3, 4, 5, 6, 7, 9	Source 4	Source of the LSD 4
10	TSA+	Thermal sensor anode
11, 12, 14, 15, 16, 17	Source 2	Source of the HSD 2
13	Drain 2	Drain of the HSD 2
18	Gate 2	Gate of the HSD 2
19	Gate 1	Gate of the HSD 1
20, 21, 22, 23, 25, 26	Source 1	Source of the HSD 1
24	Drain 1	Drain of the HSD 1
27	TSK-	Thermal sensor cathode
28, 30, 31, 32, 33, 34	Source 3	Source of the LSD 3
29, 35	Drain 3	Drain of the LSD 3
36	Gate 3	Gate of the LSD 3

2 Electrical specifications

2.1 Absolute maximum rating

Table 3. Absolute maximum rating

Symbol	Parameter	Value	Unit
V_{CC}	Supply voltage (whole bridge switched off)	72	V
I_{max}	Maximum output current (continuous)	40	A
V_{GS_max}	Maximum gate source voltage	18	V
I_{Pulse_max}	Maximum Single Pulse output current	80 ⁽¹⁾	A
T_j	Junction operating temperature	175	°C
T_c	Case operating temperature	-40 to 150	°C
T_{STG}	Storage temperature	-55 to 150	°C
I_S	Diode continuous forward current	40	A

1. Pulse duration = 20 ms (see [Figure 3](#)).

Figure 3. Single pulse maximum current

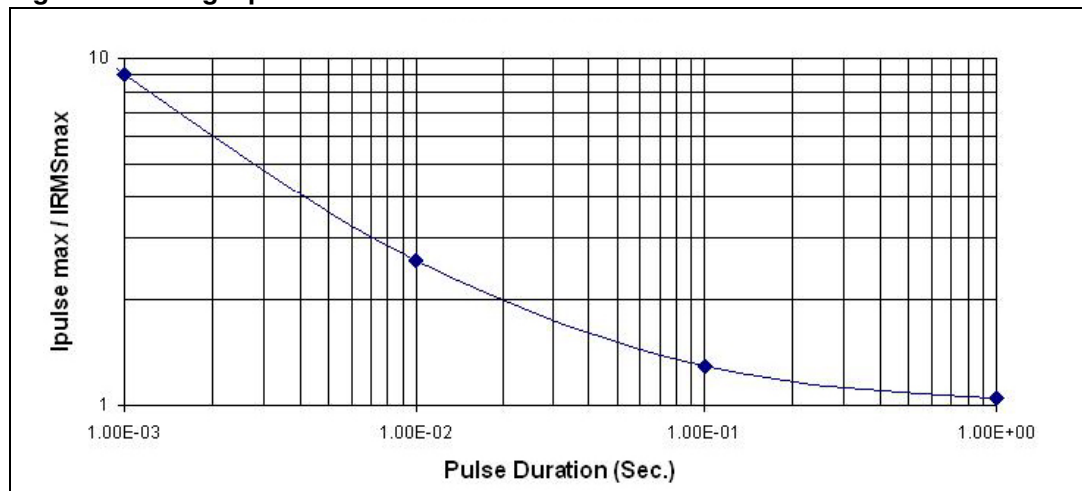

2.2 Electrical characteristics

$T_j = 25\text{ °C}$, unless otherwise specified.

Table 4. Power off

Symbol	Parameter	Test conditions	Min.	Typ.	Max.	Unit
$V_{(BR)DSS}$	Drain-source breakdown voltage	$I_D = 10\text{ mA}$, $V_{GS} = 0\text{ V}$	36	—		V
I_{DSS}	Zero gate voltage drain current ($V_{GS}=0V$)	$V_{DS} = 28\text{ V}$; $-40\text{ °C} < T_j < 150\text{ °C}$		—	100	μA
		$V_{DS} = 28\text{ V}$; $T_j = 25\text{ °C}$		—	10	μA
I_{GSS}	Gate-source leakage current ($V_{DS}=0V$)	$V_{GS} = \pm 10\text{ V}$		—	± 100	nA

Table 5. Power on

Symbol	Parameter	Test conditions	Min.	Typ.	Max.	Unit
$V_{GS(th)}$	Gate threshold voltage	$V_{DS} = V_{GS}$; $I_D = 1\text{ mA}$	2		4	V
$dV_{GS(th)}/dT$	Gate threshold voltage temperature derating	$V_{DS} = V_{GS}$; $I_D = 1\text{ mA}$		7.5		$\text{mV}/\text{°C}$
$R_{DS(on)HS}$	Static drain-source on resistance	$V_{GS} = 10\text{ V}$; $I_D = 5\text{ A}$; $T_j = 25\text{ °C}$		5.7		$\text{m}\Omega$
		$V_{GS} = 10\text{ V}$; $I_D = 5\text{ A}$; $T_j = 150\text{ °C}$			11.9	$\text{m}\Omega$
$R_{DS(on)LS}$	Static drain-source on resistance	$V_{GS} = 10\text{ V}$; $I_D = 5\text{ A}$; $T_j = 25\text{ °C}$		7.3		$\text{m}\Omega$
		$V_{GS} = 10\text{ V}$; $I_D = 5\text{ A}$; $T_j = 150\text{ °C}$			15.1	$\text{m}\Omega$

Table 6. Dynamic

Symbol	Parameter	Test condition	Min.	Typ.	Max.	Unit
$G_{fs_HS}^{(1)}$	Forward transconductance	$V_{DS} = 15\text{ V}$; $I_D = 20\text{ A}$; $T_j = 25\text{ °C}$	—	20	—	S
$G_{fs_LS}^{(1)}$	Forward transconductance		—	17.5	—	S
C_{iss_HS}	Input capacitance	$V_{DS} = 25\text{ V}$; $f = 1\text{ MHz}$; $V_{GS} = 0\text{ V}$ (see Figure 6)	—	1836	—	pF
C_{oss_HS}	Output capacitance		—	426	—	pF
C_{rss_HS}	Reverse transfer capacitance		—	55	—	pF
C_{iss_LS}	Input capacitance	$V_{DS} = 25\text{ V}$; $f = 1\text{ MHz}$; $V_{GS} = 0\text{ V}$ (see Figure 7)	—	1250	—	pF
C_{oss_LS}	Output capacitance		—	311	—	pF
C_{rss_LS}	Reverse transfer capacitance		—	49	—	pF

1. Pulsed: pulse duration = 300 μs , duty cycle 1.5%.

Table 7. Gate resistance

Symbol	Parameter	Test condition	Min.	Typ.	Max.	Unit
R _{G_HS}	Gate resistance HS	V _{DD} = 15 V; f _{gate} = 1 MHz	—	20	—	Ω
R _{G_LS}	Gate resistance LS		—	13	—	Ω

Table 8. Source drain diode

Symbol	Parameter	Test conditions	Min.	Typ.	Max.	Unit
V _{SD} ⁽¹⁾	Forward on voltage	I _{SD} = 20 A; V _{GS} = 0 V; T _j = 25 °C	—	0.9	1.1	V
t _{rr}	Reverse recovery time	I _{SD} = 20 A; di/dt = 100 A/μs; V _{DD} = 20 V; T _j = 150 °C (see Figure 10)	—	50		ns
Q _{rr}	Reverse recovery charge		—	28		nC
I _{RPM}	Reverse recovery current		—	0.8		A

1. Pulse width limited by safe operating area.

Table 9. Switching on HSD

Symbol	Parameter	Test conditions	Min.	Typ.	Max.	Unit
t _{d(on)}	Turn on delay time	V _{DD} = 15 V; I _D = 20 A; R _G = 4.7 Ω; V _{GS} = 10 V	—	53	—	ns
t _r	Rise time		—	319	—	ns
Q _g	Total gate charge	V _{DD} = 15 V; I _D = 20 A; V _{GS} = 10 V (see Figure 4 and Figure 9)	—	36	—	nC
Q _{gs}	Gate-source charge		—	8.5	—	nC
Q _{gd}	Gate-drain charge		—	5	—	nC

Table 10. Switching on LSD

Symbol	Parameter	Test conditions	Min.	Typ.	Max.	Unit
t _{d(on)}	Turn on delay time	V _{DD} = 15 V; I _D = 20 A; R _G = 4.7 Ω; V _{GS} = 10 V	—	53	—	ns
t _r	Rise time		—	430	—	ns
Q _g	Total gate charge	V _{DD} = 15 V; I _D = 20 A; V _{GS} = 10 V (see Figure 5 and Figure 9)	—	23	—	nC
Q _{gs}	Gate-source charge		—	6	—	nC
Q _{gd}	Gate-drain charge		—	2.5	—	nC

Table 11. Switching off HSD

Symbol	Parameter	Test conditions	Min.	Typ.	Max.	Unit
t _{d(off)}	Turn-off delay time	V _{DD} = 15 V; I _D = 20 A; R _G = 4.7 Ω; V _{GS} = 10 V (see Figure 11)	—	253	—	ns
t _f	Fall time		—	169	—	ns

Table 12. Switching off LSD

Symbol	Parameter	Test conditions	Min.	Typ.	Max.	Unit
$t_{d(off)}$	Turn-off delay time	$V_{DD} = 15\text{ V}; I_D = 20\text{ A};$ $R_G = 4.7\ \Omega; V_{GS} = 10\text{ V}$ (see Figure 11)	—	124	—	ns
t_f	Fall time		—	293	—	ns

Table 13. Thermal sensor⁽¹⁾

Symbol	Parameter	Test conditions	Min.	Typ.	Max.	Unit
V_F	Chain diode forward voltage	$T_j = 25\text{ }^\circ\text{C}; I_F = 250\ \mu\text{A}$ (see Figure 8)	3.72	3.88	4.04	V
S_F	Chain temperature coefficient	$-40\text{ }^\circ\text{C} < T_j < 175\text{ }^\circ\text{C}; I_F = 250\ \mu\text{A}$		-8.1		mV/°K

1. See [Figure 8](#).

Figure 4. Gate charge vs gate-source voltage HS

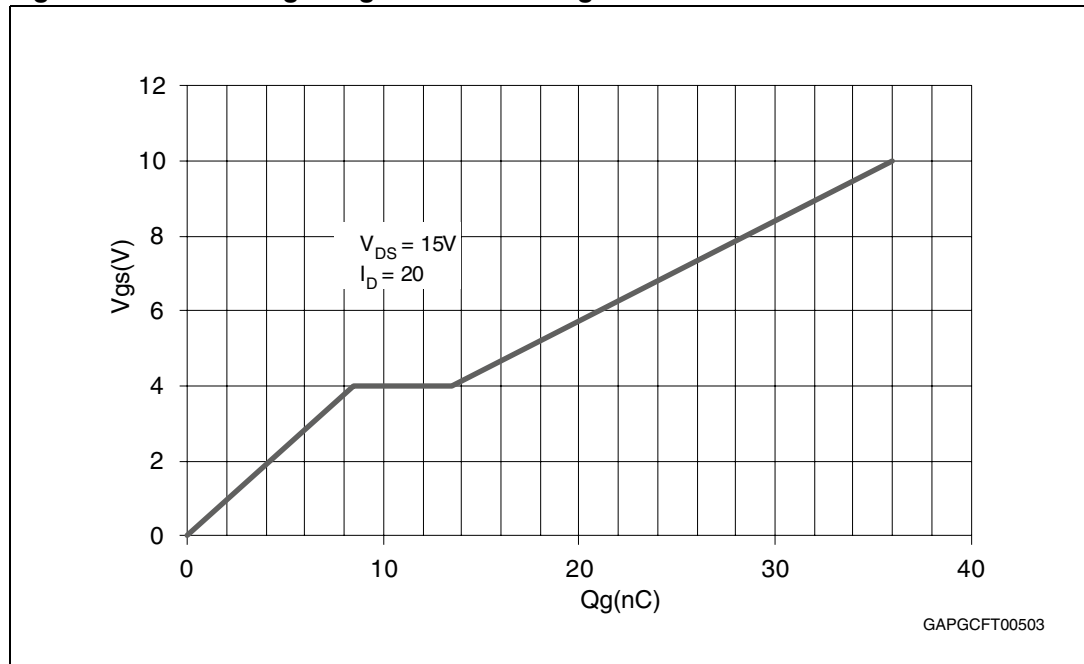

Figure 5. Gate charge vs gate-source voltage LS

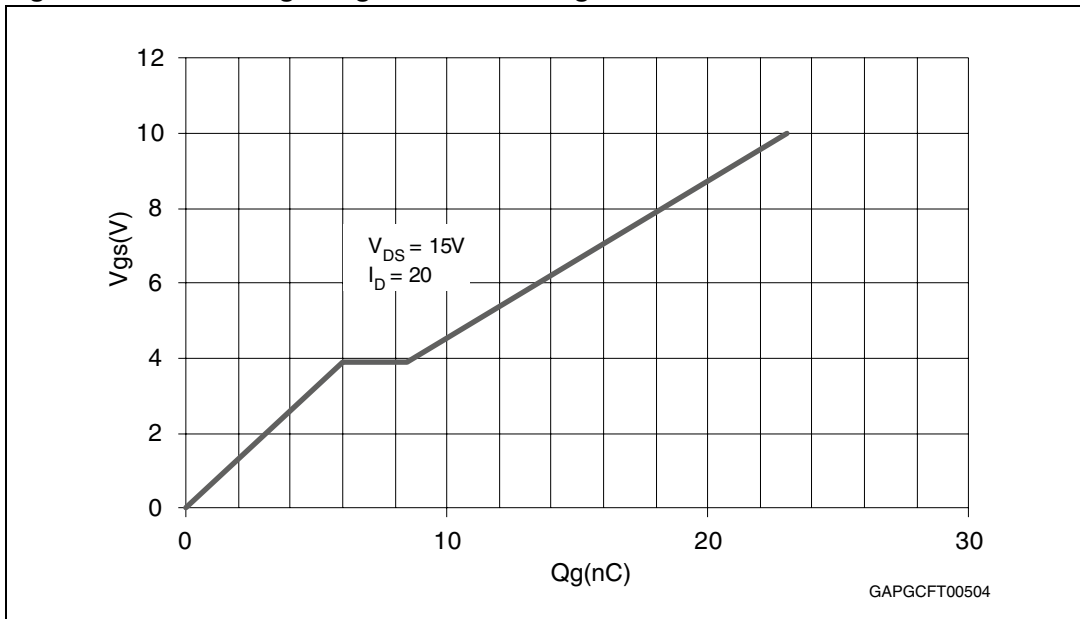

Figure 6. Capacitance variations HS

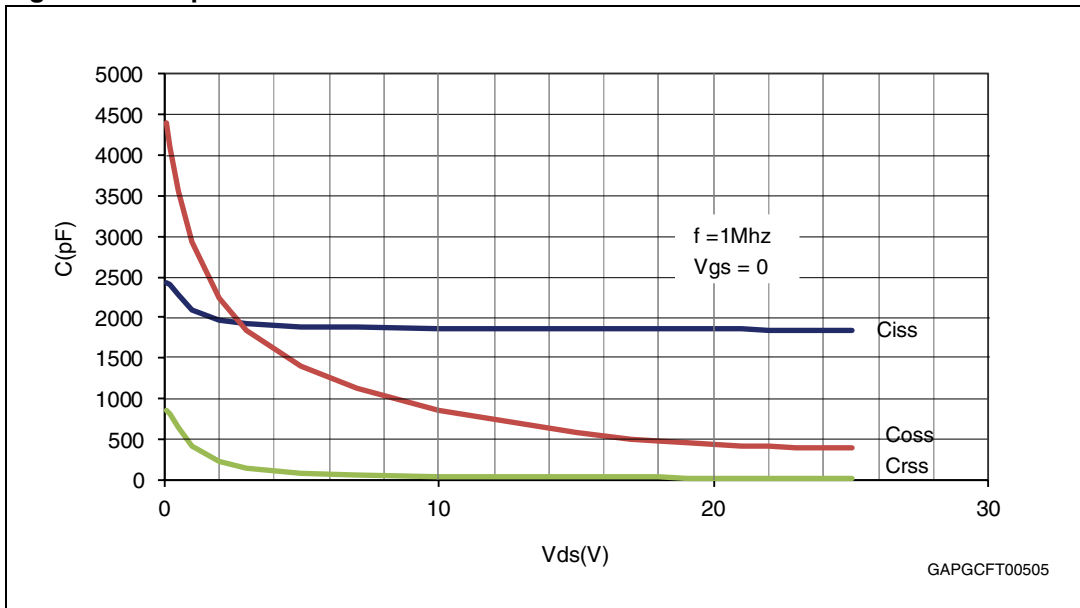

Figure 7. Capacitance variations LS

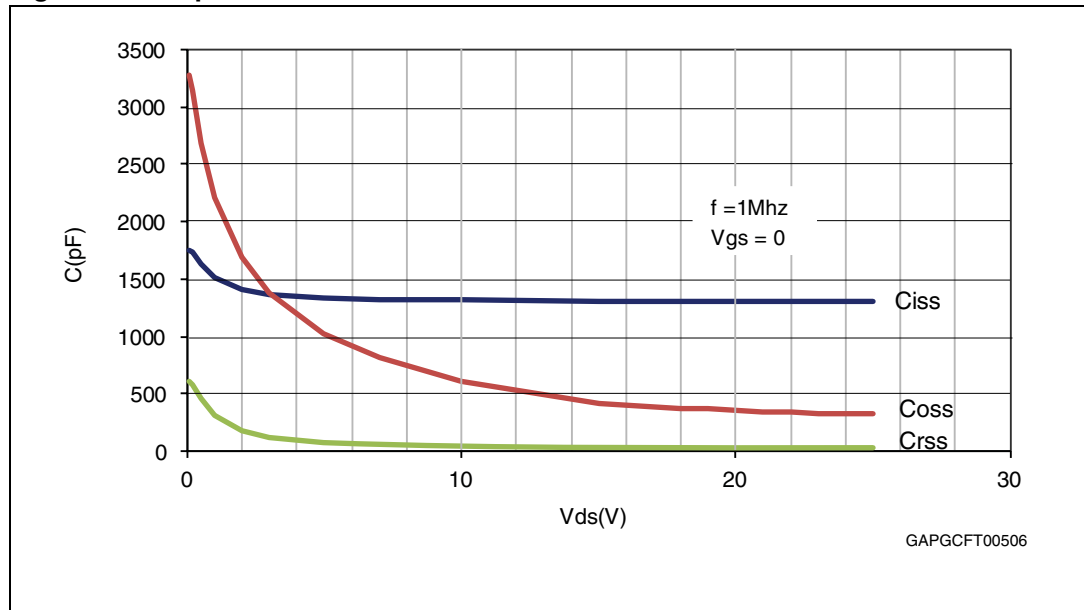

Figure 8. Thermal sensor voltage vs temperature

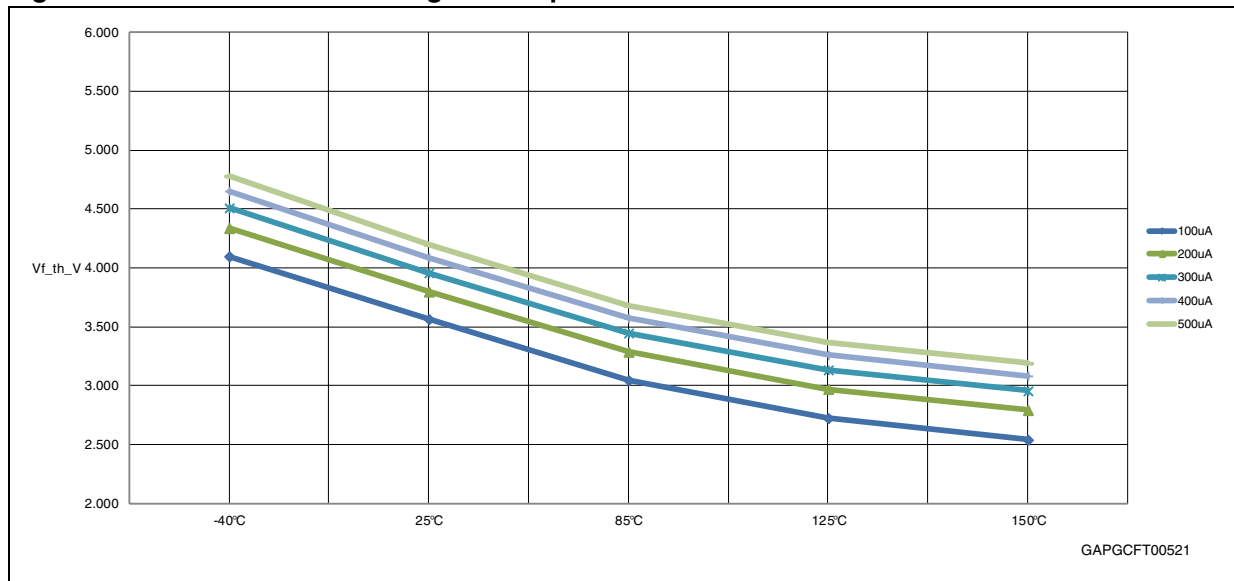

Figure 9. Gate charge test circuit

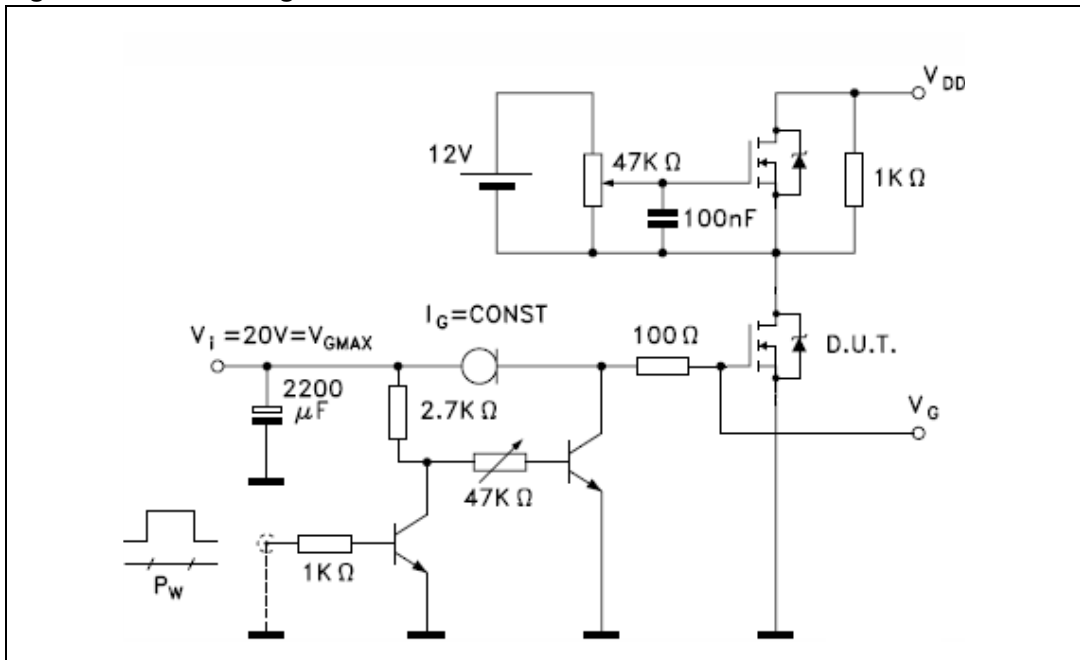

Figure 10. Test circuit for inductive load switching and diode recovery times

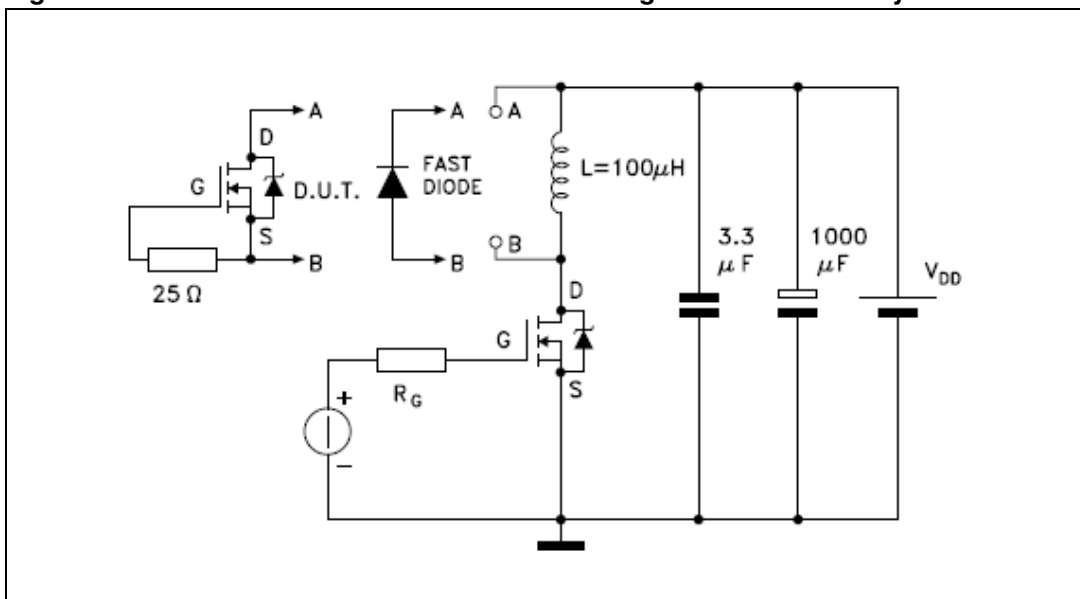
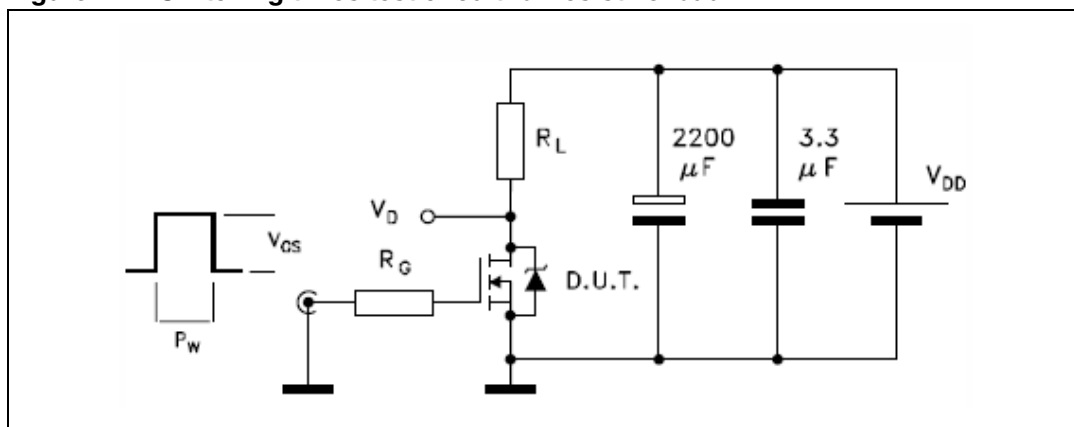

Figure 11. Switching times test circuit for resistive load



3 Package and PCB thermal data

3.1 PowerSSO-36 thermal data

Figure 12. PowerSSO-36 PC board

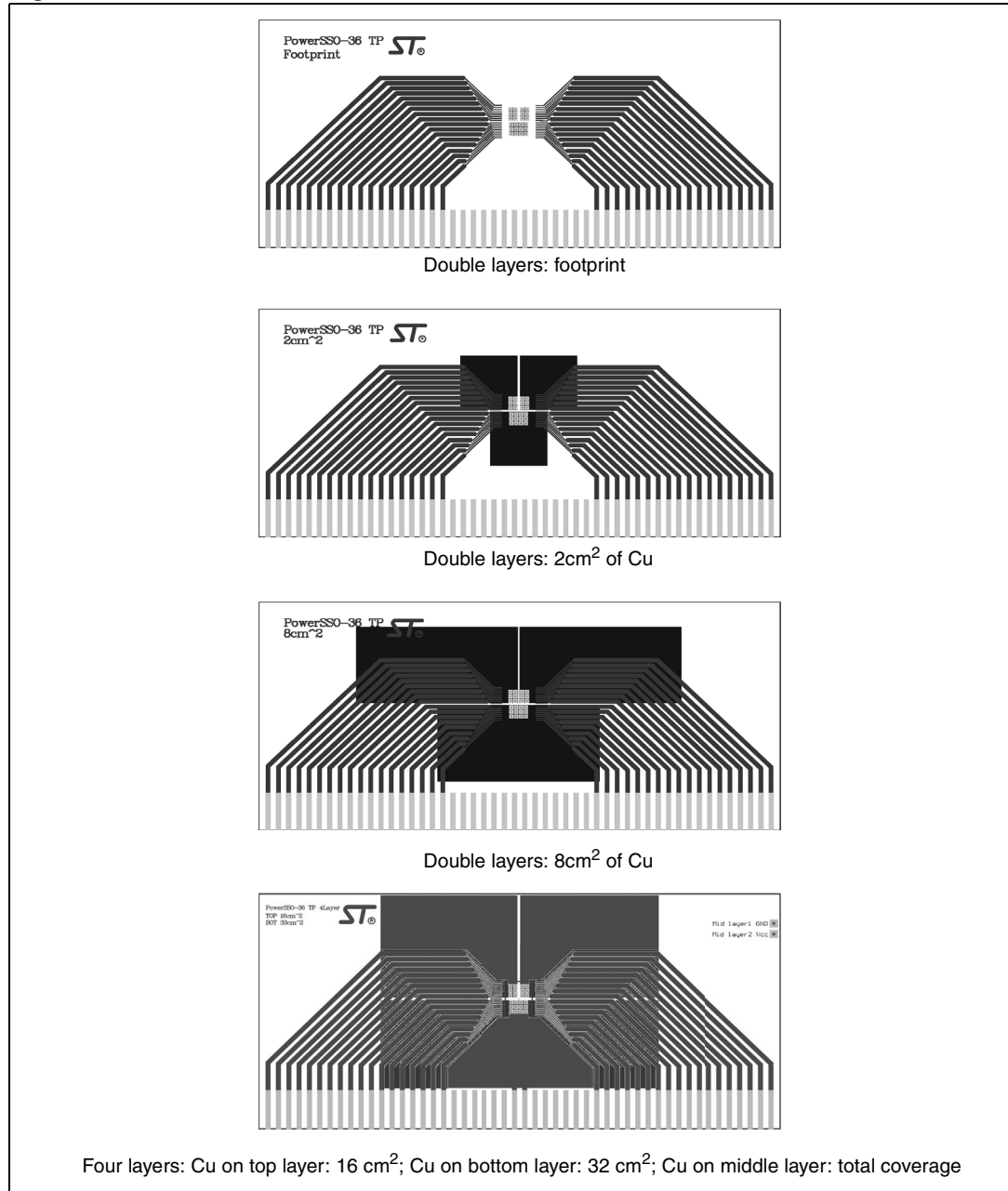

Figure 13. Chipset configuration

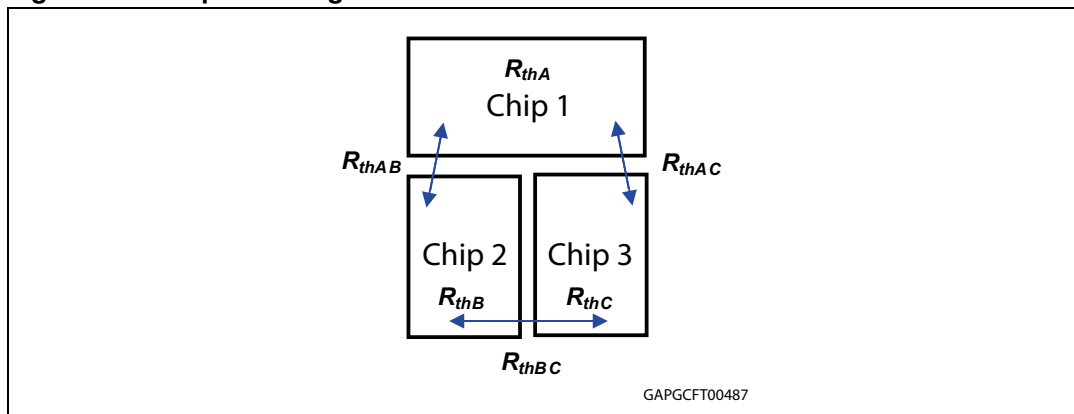
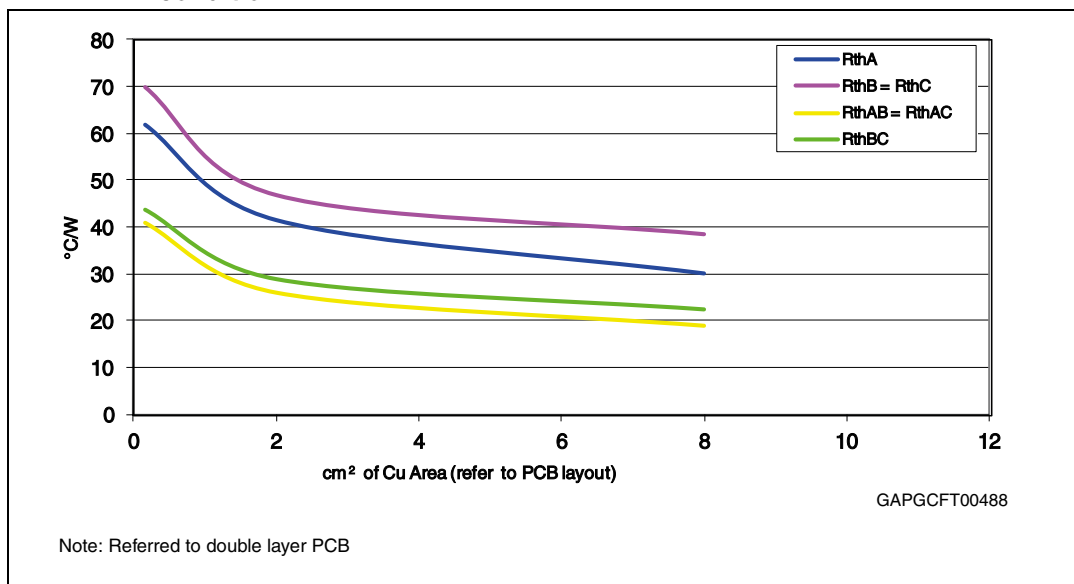

Figure 14. Auto and mutual $R_{thj-amb}$ vs PCB copper area in open box free air condition



3.1.1 Thermal calculation in clockwise and anti-clockwise operation in steady-state mode

Table 14. Thermal calculation in clockwise and anti-clockwise operation in steady-state mode

HS_A	HS_B	LS_A	LS_B	T_{jHSAB}	T_{jLSA}	T_{jLSB}
ON	OFF	OFF	ON	$P_{dHS_A} \times R_{thHS} + P_{dLS_B} \times R_{thHSLS} + T_{amb}$	$P_{dHS_A} \times R_{thHSLS} + P_{dLS_B} \times R_{thLSLS} + T_{amb}$	$P_{dHS_A} \times R_{thHSLS} + P_{dLS_B} \times R_{thLS} + T_{amb}$
OFF	ON	ON	OFF	$P_{dHS_B} \times R_{thHS} + P_{dLS_A} \times R_{thHSLS} + T_{amb}$	$P_{dHS_B} \times R_{thHSLS} + P_{dLS_A} \times R_{thLS} + T_{amb}$	$P_{dHS_B} \times R_{thHSLS} + P_{dLS_A} \times R_{thLSLS} + T_{amb}$

3.1.2 Thermal resistances definition (values according to the PCB heatsink area)

$R_{thHS} = R_{thHSA} = R_{thHSB}$ = High Side Chip Thermal Resistance Junction to Ambient (HS_A or HS_B in ON state)

$R_{thLS} = R_{thLSA} = R_{thLSB}$ = Low Side Chip Thermal Resistance Junction to Ambient

$R_{thHSLs} = R_{thHSALsB} = R_{thHSBLsA}$ = Mutual Thermal Resistance Junction to Ambient between High Side and Low Side Chips

$R_{thLSLs} = R_{thLSALsB} = R_{thLSBLsA}$ = Mutual Thermal Resistance Junction to Ambient between Low Side Chips

3.1.3 Thermal calculation in transient mode^(a)

$T_{jHSAB} = Z_{thHS} \times P_{dHSAB} + Z_{thHSLs} \times (P_{dLSA} + P_{dLSB}) + T_{amb}$

$T_{jLSA} = Z_{thHSLs} \times P_{dHSAB} + Z_{thLS} \times P_{dLSA} + Z_{thLSLs} \times P_{dLSB} + T_{amb}$

$T_{jLSB} = Z_{thHSLs} \times P_{dHSAB} + Z_{thLSLs} \times P_{dLSA} + Z_{thLS} \times P_{dLSB} + T_{amb}$

3.1.4 Single pulse thermal impedance definition (values according to the PCB heatsink area)

Z_{thHS} = High Side Chip Thermal Impedance Junction to Ambient

$Z_{thLS} = Z_{thLSA} = Z_{thLSB}$ = Low Side Chip Thermal Impedance Junction to Ambient

$Z_{thHSLs} = Z_{thHSABLsA} = Z_{thHSABLsB}$ = Mutual Thermal Impedance Junction to Ambient between High Side and Low Side Chips

$Z_{thLSLs} = Z_{thLSALsB} = Z_{thLSBLsA}$ = Mutual Thermal Impedance Junction to Ambient between Low Side Chips

Equation 1: pulse calculation formula

$$Z_{TH\delta} = R_{TH} P \delta + Z_{THtp}(1 - \delta)$$

where $\delta = t_p / T$

a. Calculation is valid in any dynamic operating condition. P_d values set by user.

Figure 15. PowerSSO-36 HSD thermal impedance junction ambient single pulse

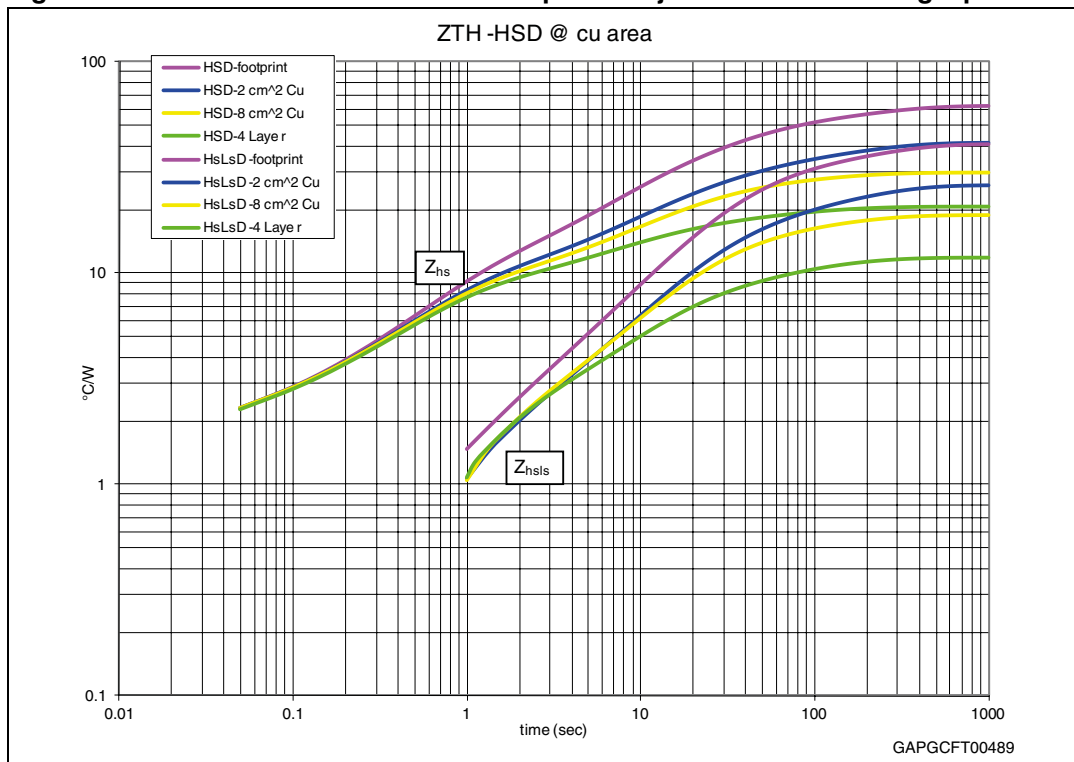

Figure 16. PowerSSO-36 LSD thermal impedance junction ambient single pulse

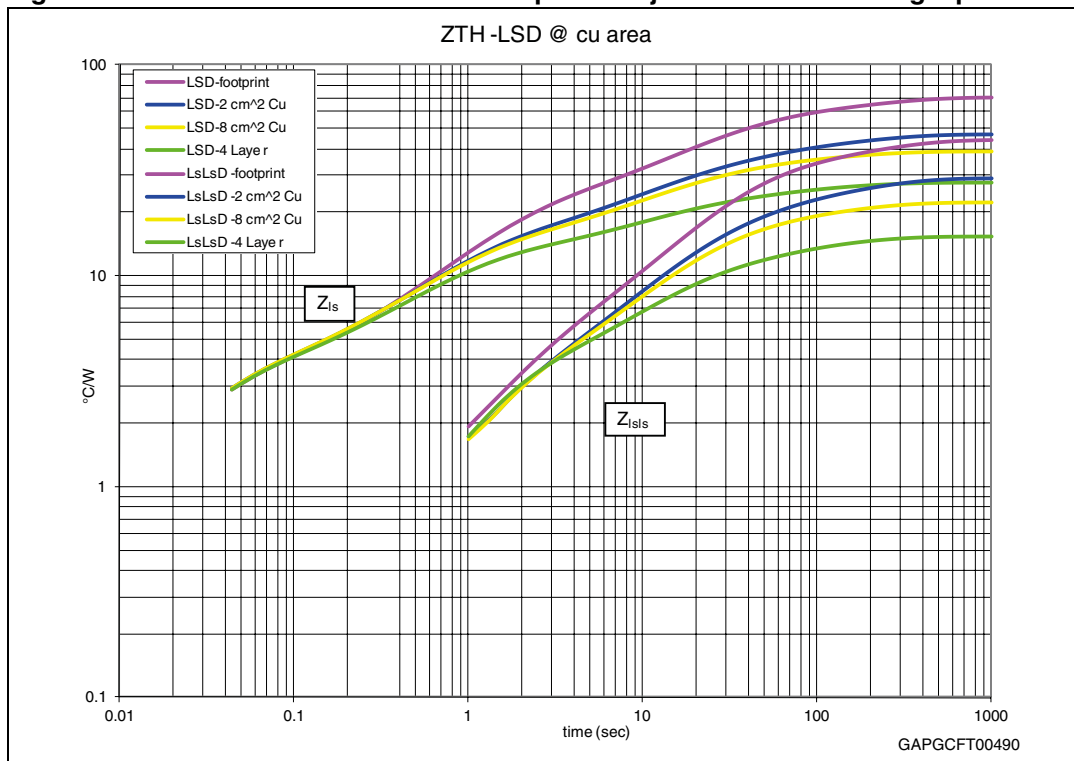

Figure 17. Thermal fitting model of an H-bridge in PowerSSO-36

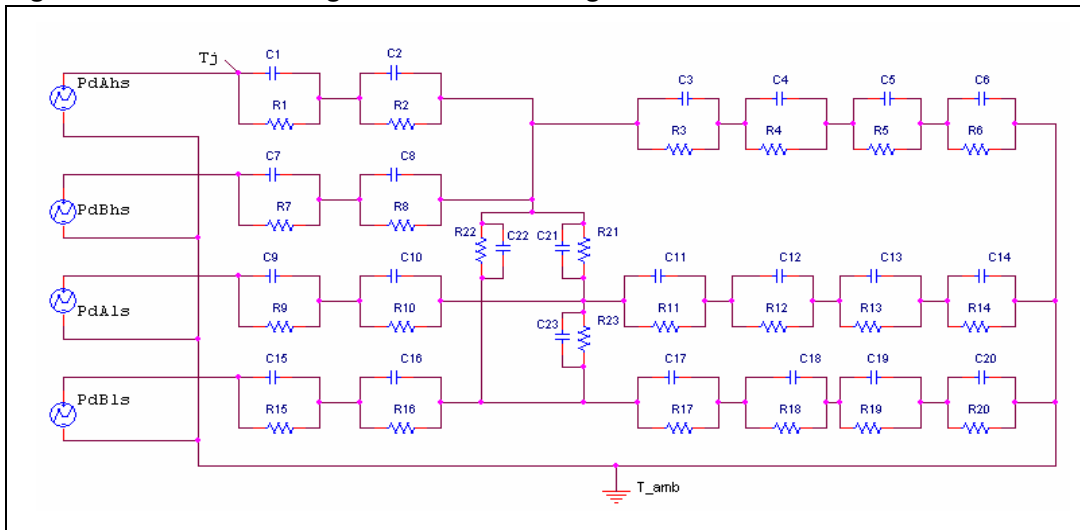

Table 15. Thermal parameters⁽¹⁾

Area/island (cm ²)	Footprint	2	8	4L
R1 = R7 (°C/W)	0.2			
R2 = R8 (°C/W)	1.6			
R3 (°C/W)	8			
R4 (°C/W)	30	16	16	10
R5 (°C/W)	40	22	12	5
R6 (°C/W)	36	28	10	6
R9 = R15 (°C/W)	0.1			
R10 = R16 (°C/W)	2.8			
R11 = R17 (°C/W)	22	14	14	14
R12 = R18 (°C/W)	49	30	30	20
R13 = R19 (°C/W)	52	36	28	16
R14 = R20 (°C/W)	50	32	26	18
R21 = R22 (°C/W)	80	60	50	40
R23 (°C/W)	80	50	45	30
C1 = C7 = C9 = C15 (W.s/°C)	0.001			
C2 = C8 (W.s/°C)	0.009			
C3 (W.s/°C)	0.09			
C4 (W.s/°C)	0.5	0.8	0.8	0.8
C5 (W.s/°C)	0.8	1.4	2	3
C6 (W.s/°C)	5	6	8	10
C10 = C16 (W.s/°C)	0.1			
C11 = C17 (W.s/°C)	0.07			
C12 = C18 (W.s/°C)	0.45	0.45	0.45	0.6
C13 = C19 (W.s/°C)	0.8	1	1.2	2.5
C14 = C20 (W.s/°C)	4	5	6	8
C21 = C22 = C23 (W.s/°C)	0.01	0.006	0.005	0.005

1. The blank space means that the value is the same as the previous one.

4 Package and packing information

4.1 ECOPACK® packages

In order to meet environmental requirements, ST offers these devices in different grades of ECOPACK® packages, depending on their level of environmental compliance. ECOPACK® specifications, grade definitions and product status are available at: www.st.com.

ECOPACK® is an ST trademark.

4.2 PowerSSO-36 TP package information

Figure 18. PowerSSO-36 TP package dimensions

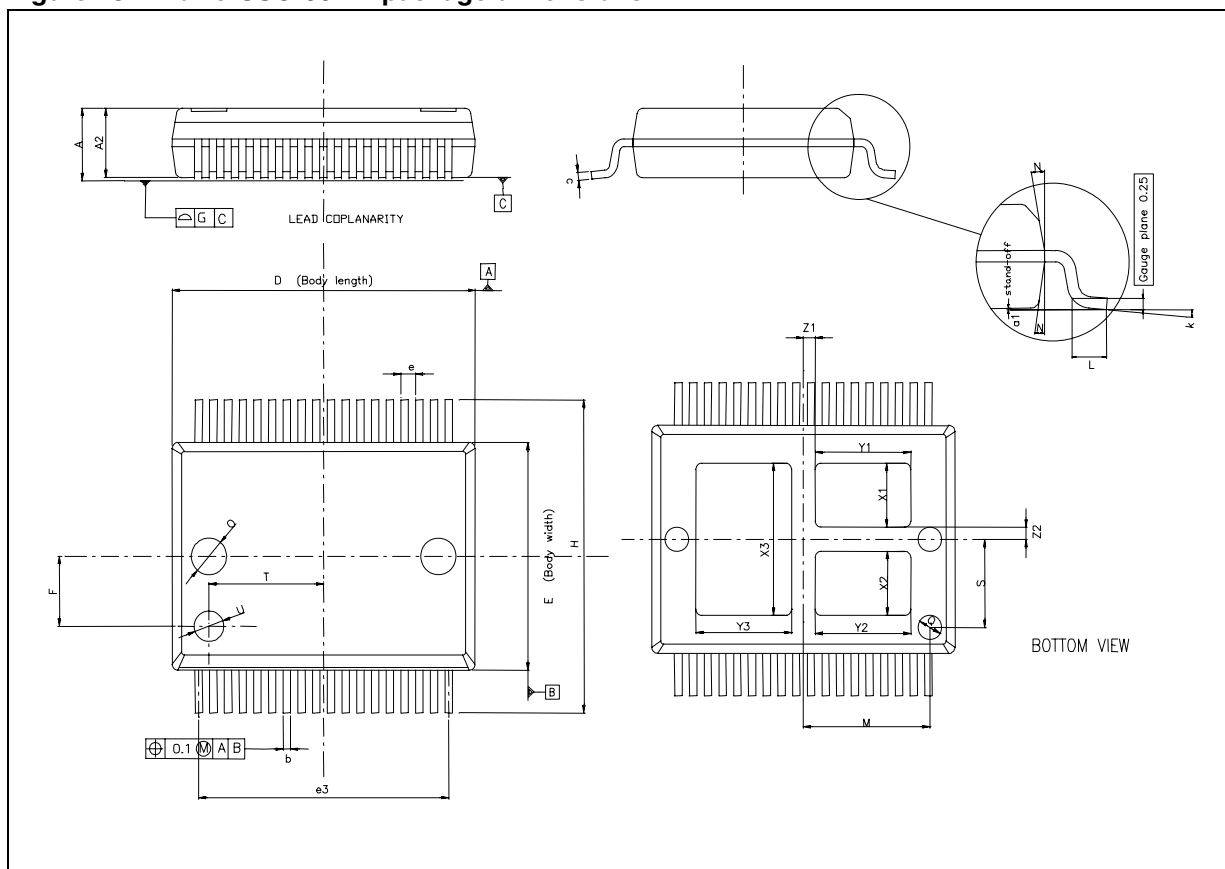

Table 16. PowerSSO-36 TP mechanical data

Symbol	Millimeters		
	Min.	Typ.	Max.
A	2.15		2.47
A2	2.15		2.40
a1	0		0.1
b	0.18		0.36
c	0.23		0.32
D	10.10		10.50
E	7.4		7.6
e		0.5	
e3		8.5	
F		2.3	
G			0.1
H	10.1		10.5
h			0.4
k	0 deg		8 deg
L	0.6		1
M		4.3	
N			10 deg
O		1.2	
Q		0.8	
S		2.9	
T		3.65	
U		1.0	
X1	1.85		2.35
Y1	3		3.5
X2	1.85		2.35
Y2	3		3.5
X3	4.7		5.2
Y3	3		3.5
Z1		0.4	
Z2		0.4	

4.3 PowerSSO-36 TP packing information

Figure 19. PowerSSO-36 TP tube shipment (no suffix)

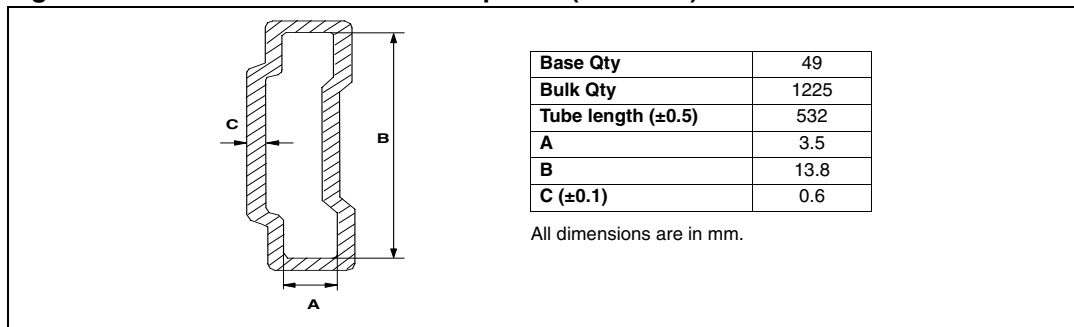
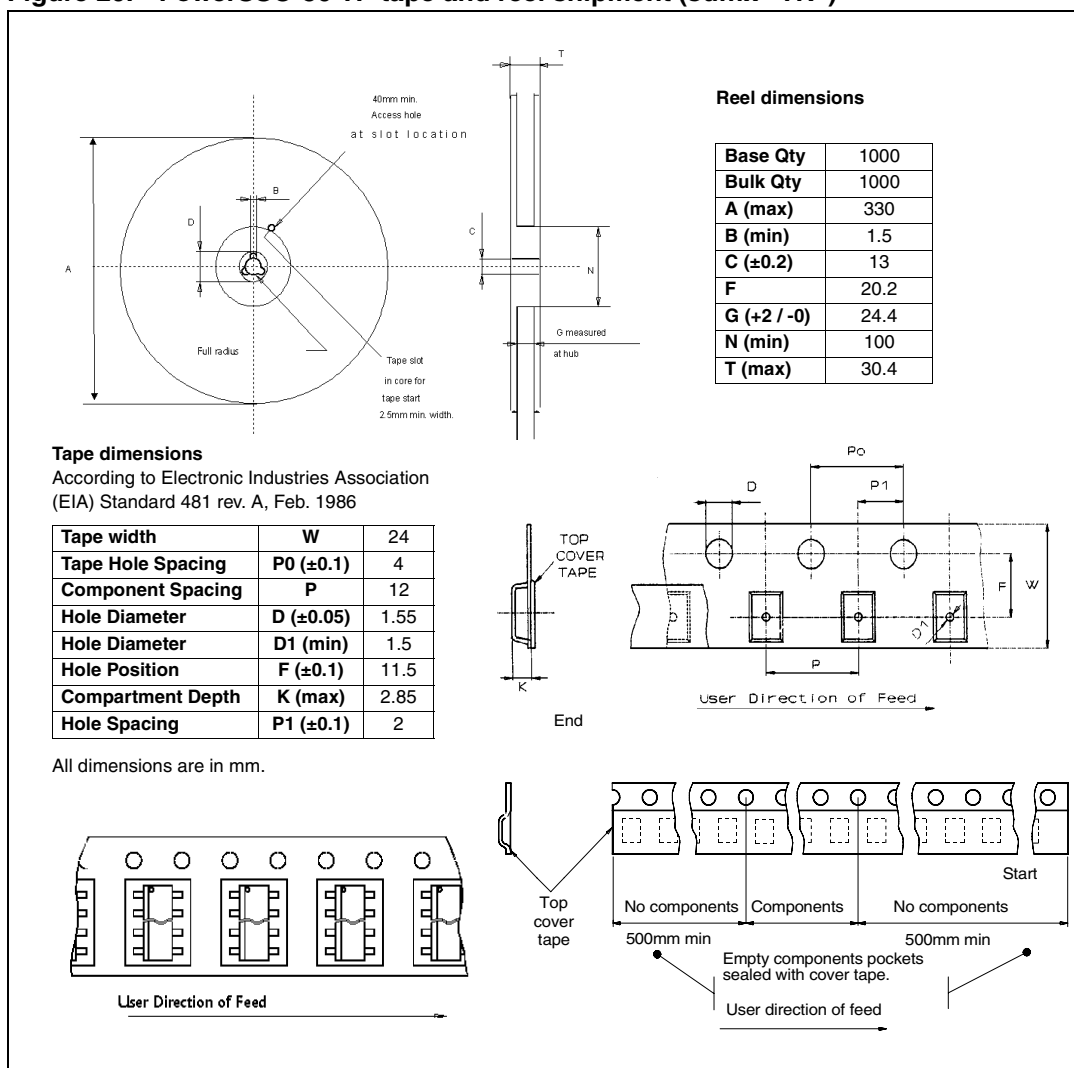

Figure 20. PowerSSO-36 TP tape and reel shipment (suffix "TR")



5 Revision history

Table 17. Document revision history

Date	Revision	Changes
07-Nov-2011	1	Initial release
18-Jan-2012	2	Changed document status from preliminary data to datasheet.
20-Jan-2012	3	Updated features list.

Please Read Carefully:

Information in this document is provided solely in connection with ST products. STMicroelectronics NV and its subsidiaries ("ST") reserve the right to make changes, corrections, modifications or improvements, to this document, and the products and services described herein at any time, without notice.

All ST products are sold pursuant to ST's terms and conditions of sale.

Purchasers are solely responsible for the choice, selection and use of the ST products and services described herein, and ST assumes no liability whatsoever relating to the choice, selection or use of the ST products and services described herein.

No license, express or implied, by estoppel or otherwise, to any intellectual property rights is granted under this document. If any part of this document refers to any third party products or services it shall not be deemed a license grant by ST for the use of such third party products or services, or any intellectual property contained therein or considered as a warranty covering the use in any manner whatsoever of such third party products or services or any intellectual property contained therein.

UNLESS OTHERWISE SET FORTH IN ST'S TERMS AND CONDITIONS OF SALE ST DISCLAIMS ANY EXPRESS OR IMPLIED WARRANTY WITH RESPECT TO THE USE AND/OR SALE OF ST PRODUCTS INCLUDING WITHOUT LIMITATION IMPLIED WARRANTIES OF MERCHANTABILITY, FITNESS FOR A PARTICULAR PURPOSE (AND THEIR EQUIVALENTS UNDER THE LAWS OF ANY JURISDICTION), OR INFRINGEMENT OF ANY PATENT, COPYRIGHT OR OTHER INTELLECTUAL PROPERTY RIGHT.

UNLESS EXPRESSLY APPROVED IN WRITING BY TWO AUTHORIZED ST REPRESENTATIVES, ST PRODUCTS ARE NOT RECOMMENDED, AUTHORIZED OR WARRANTED FOR USE IN MILITARY, AIR CRAFT, SPACE, LIFE SAVING, OR LIFE SUSTAINING APPLICATIONS, NOR IN PRODUCTS OR SYSTEMS WHERE FAILURE OR MALFUNCTION MAY RESULT IN PERSONAL INJURY, DEATH, OR SEVERE PROPERTY OR ENVIRONMENTAL DAMAGE. ST PRODUCTS WHICH ARE NOT SPECIFIED AS "AUTOMOTIVE GRADE" MAY ONLY BE USED IN AUTOMOTIVE APPLICATIONS AT USER'S OWN RISK.

Resale of ST products with provisions different from the statements and/or technical features set forth in this document shall immediately void any warranty granted by ST for the ST product or service described herein and shall not create or extend in any manner whatsoever, any liability of ST.

ST and the ST logo are trademarks or registered trademarks of ST in various countries.

Information in this document supersedes and replaces all information previously supplied.

The ST logo is a registered trademark of STMicroelectronics. All other names are the property of their respective owners.

© 2012 STMicroelectronics - All rights reserved

STMicroelectronics group of companies

Australia - Belgium - Brazil - Canada - China - Czech Republic - Finland - France - Germany - Hong Kong - India - Israel - Italy - Japan - Malaysia - Malta - Morocco - Philippines - Singapore - Spain - Sweden - Switzerland - United Kingdom - United States of America

www.st.com

Компания «Life Electronics» занимается поставками электронных компонентов импортного и отечественного производства от производителей и со складов крупных дистрибьюторов Европы, Америки и Азии.

С конца 2013 года компания активно расширяет линейку поставок компонентов по направлению коаксиальный кабель, кварцевые генераторы и конденсаторы (керамические, пленочные, электролитические), за счёт заключения дистрибьюторских договоров

Мы предлагаем:

- Конкуренспособные цены и скидки постоянным клиентам.
- Специальные условия для постоянных клиентов.
- Подбор аналогов.
- Поставку компонентов в любых объемах, удовлетворяющих вашим потребностям.
- Приемлемые сроки поставки, возможна ускоренная поставка.
- Доставку товара в любую точку России и стран СНГ.
- Комплексную поставку.
- Работу по проектам и поставку образцов.
- Формирование склада под заказчика.
- Сертификаты соответствия на поставляемую продукцию (по желанию клиента).
- Тестирование поставляемой продукции.
- Поставку компонентов, требующих военную и космическую приемку.
- Входной контроль качества.
- Наличие сертификата ISO.

В составе нашей компании организован Конструкторский отдел, призванный помогать разработчикам, и инженерам.

Конструкторский отдел помогает осуществить:

- Регистрацию проекта у производителя компонентов.
- Техническую поддержку проекта.
- Защиту от снятия компонента с производства.
- Оценку стоимости проекта по компонентам.
- Изготовление тестовой платы монтаж и пусконаладочные работы.



Тел: +7 (812) 336 43 04 (многоканальный)

Email: org@lifeelectronics.ru