

Stripline PIN Diode Switch Modules

V5

Features

- ◆ Broadband 50 Ohm Design Through X Band
- ◆ High Power Handling
- ◆ Voltage Ratings to 1000V
- ◆ Fast Switching Speeds
- ◆ Hermetically Sealed Package
- ◆ RoHS Compliant

Description

These M/A-Com Technology Solutions switch modules consist of a shunt mounted, passivated, PIN diode chip in a hermetically sealed strip-line package. These modules are optimized for use in a 50 ohm micro-strip or strip-line circuit. By incorporating the appropriate series inductance to produce a matched low pass filter structure in a zero or reverse bias condition, no external matching is required. To achieve high isolation, a forward bias current between +10mA to +100mA is applied to the center conductor which changes the module's inductive impedance from a high to a low-impedance state causing the RF power to be reflected.

Applications

The M/A-COM Technology Solutions MA47200 series modules maybe operated as a SPST reflective switch or as an attenuator by applying the appropriate forward or reverse DC bias. These broadband modules are designed to operate at frequencies from VHF through X Band. A variety of modules are available which offer a choice of breakdown voltages and switching speeds.

Specifications subject to change without prior notification.

Absolute Maximum Rating¹ @ T_A = +25°C (unless otherwise specified)

Parameter	Rating
Voltage	Voltage rating per pg. 2 table
Operating Temperature	- 65°C to +150°C
Storage Temperature	-65°C to +175°C
Power Dissipation	$P_{DISS} = \frac{150^{\circ}\text{C} - T_{\text{AMBIENT}}}{\text{Thermal Resistance}}$

1. Operation of the device above any one of these parameters may cause permanent damage.

Available Stripline Packages

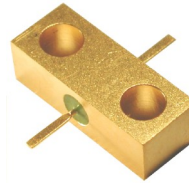

ODS-144



ODS-114

Internal Wiring Diagram

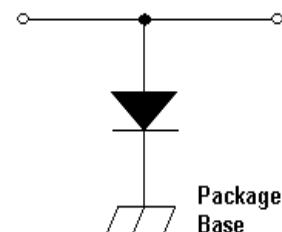

Stripline PIN Diode Switch Modules

V5

All Specifications (T_{AMB} = +25°C)

Part Number	Maximum Reverse Voltage ¹ @ I _R < 10μA Volts	Maximum Chip Capacitance f = 1MHz pF	Maximum Series Resistance Ω	Maximum Series Resistance Ω	Maximum Thermal Resistance °C/W	Nominal Characteristics	
						Carrier Lifetime ² nS	I-Region Width Microns μm
MA47208	1000	V _R = -100V C _J ≤ 1.3pF	I _F = 50mA Freq. = 100MHz R _S ≤ .400 Ω	I _F = 100mA Freq. = 100MHz R _S ≤ .300 Ω	10	1300	125
MA47222	150	V _R = -10V C _J ≤ .09pF	I _F = 10mA Freq. = 500MHz R _S ≤ 1.6 Ω	I _F = 100mA Freq. = 500MHz R _S ≤ 1.2 Ω	40	160	13
MA47223	500	V _R = -50V C _J ≤ .20pF		I _F = 100mA Freq. = 500MHz R _S ≤ .6 Ω	20	1000	50

Notes:

1. The maximum specified V_R (reverse voltage) is sourced and the resultant reverse leakage current, I_r, is measured to be <10μA.
2. Nominal carrier life time specified with diode biased at I_F = +10mA , I_{REV} = -6mA

Part Number ¹	Package Style	Test Frequency GHz	Maximum Insertion ³ Loss dB	Minimum Isolation dB	Nominal Switching Speed (nS)	
					RF Off to RF On	RF On to RF Off
MA47208	114	1	V _R = 20V Loss ≤ 0.25dB	I _F = 25mA Isolation ≤ 30dB	300	150
MA47222	144	8	V _R = 0V Loss ≤ 0.50dB	I _F = 100mA Isolation ≤ 20dB	100	30
MA47223	144	4-8 ²	V _R = 0V Loss ≤ 0.50dB	I _F = 100mA Isolation ≤ 20dB	150	30

Notes:

1. All models have cathode heatsink
2. Swept frequency measurement
3. Maximum VSWR is 1.5:1 at specified insertion loss condition.

Stripline PIN Diode Switch Modules

V5

Outline Drawing

Package Style 144

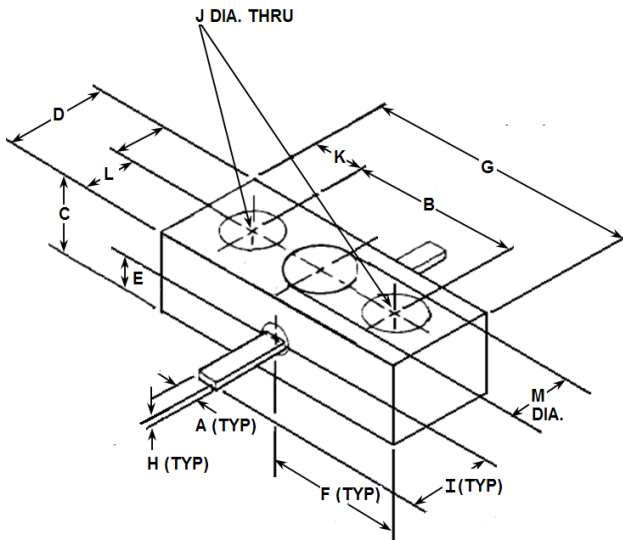

Package Style 114

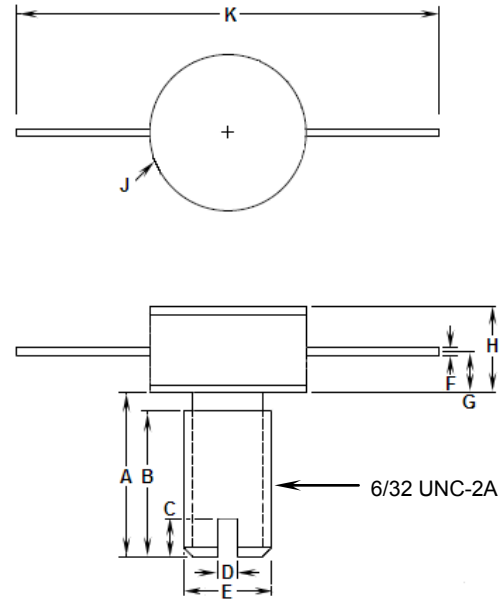

DIMS.	MILS		MILLIMETERS	
	MIN.	MAX.	MIN.	MAX.
A	22 NOMINAL		.558 NOMINAL	
B	250 NOMINAL		6.35 NOMINAL	
C	125 NOMINAL		3.175 NOMINAL	
D	155	165	3.937	4.191
E	65 NOMINAL		1.651 NOMINAL	
F	195	215	4.953	5.461
G	405	415	10.287	10.541
H	3		0.076	
I	120		3.048	
J	96 NOMINAL		2.438 NOMINAL	
K	75	85	1.905	2.159
L	80 NOMINAL		2.032 NOMINAL	
M	125 NOMINAL		3.175 NOMINAL	

DIMS.	MILS		MILLIMETERS	
	MIN.	MAX.	MIN.	MAX.
A	255	265	6.48	6.73
B	205		5.21	
C	60 NOMINAL		1.52 NOMINAL	
D	30 NOMINAL		0.76 NOMINAL	
E	131	137	3.33	3.51
F	11	13	0.28	0.33
G	58	72	1.47	1.73
H	120	140	3.05	3.56
J		255 DIA.		6.48 DIA.
K	670 NOMINAL		17.02 NOMINAL	

Stripline PIN Diode Switch Modules

V5

Environmental Ratings (Per MIL-STD 750)

The following table is recommended for Group B & C testing for TX and TXV level screening.

Inspection	Method	Condition
Storage Temperature	1031	- 65°C to +175°C
Operating Temperature	—	- 65°C to +150°C
Temperature Cycling	1051	5 cycles - 65° to + 150°C
Shock	2016	500 g's
Vibration	2056	15 g's
Constant Acceleration	2006	20,000 g's
Humidity	1021	10 days

Screened Diodes (Per MIL-STD 750)

Suggested 100% preconditioning and screening for TX level and TXV level screening.

Inspection	Method	Condition
Internal Visual	2074	See Note 1
High Temp. Storage	1032	48 hours minimum @ max. storage temp.
Thermal Shock	1051	10 Cycles
Constant Acceleration	2006	20,000 g's, Y1
Fine Leak	1071	H
Gross Leak	1071	C or E
Electrical	—	See Note
Burn-In	1038	See Note

1. Conditions and details of test depend on specific model number. Information available upon request.

M/A-COM Technology Solutions Inc. All rights reserved.

Information in this document is provided in connection with M/A-COM Technology Solutions Inc ("MACOM") products. These materials are provided by MACOM as a service to its customers and may be used for informational purposes only. Except as provided in MACOM's Terms and Conditions of Sale for such products or in any separate agreement related to this document, MACOM assumes no liability whatsoever. MACOM assumes no responsibility for errors or omissions in these materials. MACOM may make changes to specifications and product descriptions at any time, without notice. MACOM makes no commitment to update the information and shall have no responsibility whatsoever for conflicts or incompatibilities arising from future changes to its specifications and product descriptions. No license, express or implied, by estoppel or otherwise, to any intellectual property rights is granted by this document.

THESE MATERIALS ARE PROVIDED "AS IS" WITHOUT WARRANTY OF ANY KIND, EITHER EXPRESS OR IMPLIED, RELATING TO SALE AND/OR USE OF MACOM PRODUCTS INCLUDING LIABILITY OR WARRANTIES RELATING TO FITNESS FOR A PARTICULAR PURPOSE, CONSEQUENTIAL OR INCIDENTAL DAMAGES, MERCHANTABILITY, OR INFRINGEMENT OF ANY PATENT, COPYRIGHT OR OTHER INTELLECTUAL PROPERTY RIGHT. MACOM FURTHER DOES NOT WARRANT THE ACCURACY OR COMPLETENESS OF THE INFORMATION, TEXT, GRAPHICS OR OTHER ITEMS CONTAINED WITHIN THESE MATERIALS. MACOM SHALL NOT BE LIABLE FOR ANY SPECIAL, INDIRECT, INCIDENTAL, OR CONSEQUENTIAL DAMAGES, INCLUDING WITHOUT LIMITATION, LOST REVENUES OR LOST PROFITS, WHICH MAY RESULT FROM THE USE OF THESE MATERIALS.

MACOM products are not intended for use in medical, lifesaving or life sustaining applications. MACOM customers using or selling MACOM products for use in such applications do so at their own risk and agree to fully indemnify MACOM for any damages resulting from such improper use or sale.

5

M/A-COM Technology Solutions Inc. (MACOM) and its affiliates reserve the right to make changes to the product(s) or information contained herein without notice.
Visit www.macom.com for additional data sheets and product information.

Компания «Life Electronics» занимается поставками электронных компонентов импортного и отечественного производства от производителей и со складов крупных дистрибьюторов Европы, Америки и Азии.

С конца 2013 года компания активно расширяет линейку поставок компонентов по направлению коаксиальный кабель, кварцевые генераторы и конденсаторы (керамические, пленочные, электролитические), за счёт заключения дистрибьюторских договоров

Мы предлагаем:

- Конкурентоспособные цены и скидки постоянным клиентам.
- Специальные условия для постоянных клиентов.
- Подбор аналогов.
- Поставку компонентов в любых объемах, удовлетворяющих вашим потребностям.
- Приемлемые сроки поставки, возможна ускоренная поставка.
- Доставку товара в любую точку России и стран СНГ.
- Комплексную поставку.
- Работу по проектам и поставку образцов.
- Формирование склада под заказчика.
- Сертификаты соответствия на поставляемую продукцию (по желанию клиента).
- Тестирование поставляемой продукции.
- Поставку компонентов, требующих военную и космическую приемку.
- Входной контроль качества.
- Наличие сертификата ISO.

В составе нашей компании организован Конструкторский отдел, призванный помогать разработчикам, и инженерам.

Конструкторский отдел помогает осуществить:

- Регистрацию проекта у производителя компонентов.
- Техническую поддержку проекта.
- Защиту от снятия компонента с производства.
- Оценку стоимости проекта по компонентам.
- Изготовление тестовой платы монтаж и пусконаладочные работы.



Тел: +7 (812) 336 43 04 (многоканальный)

Email: org@lifeelectronics.ru