

WITH ATTACHMENT

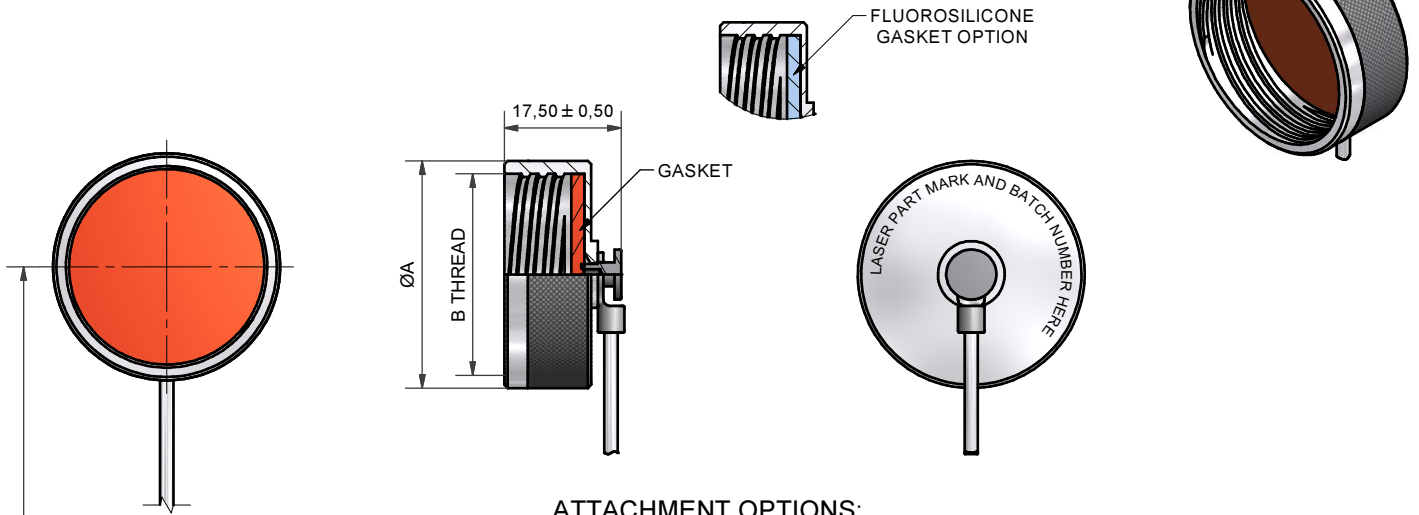

ATTACHMENT OPTIONS:

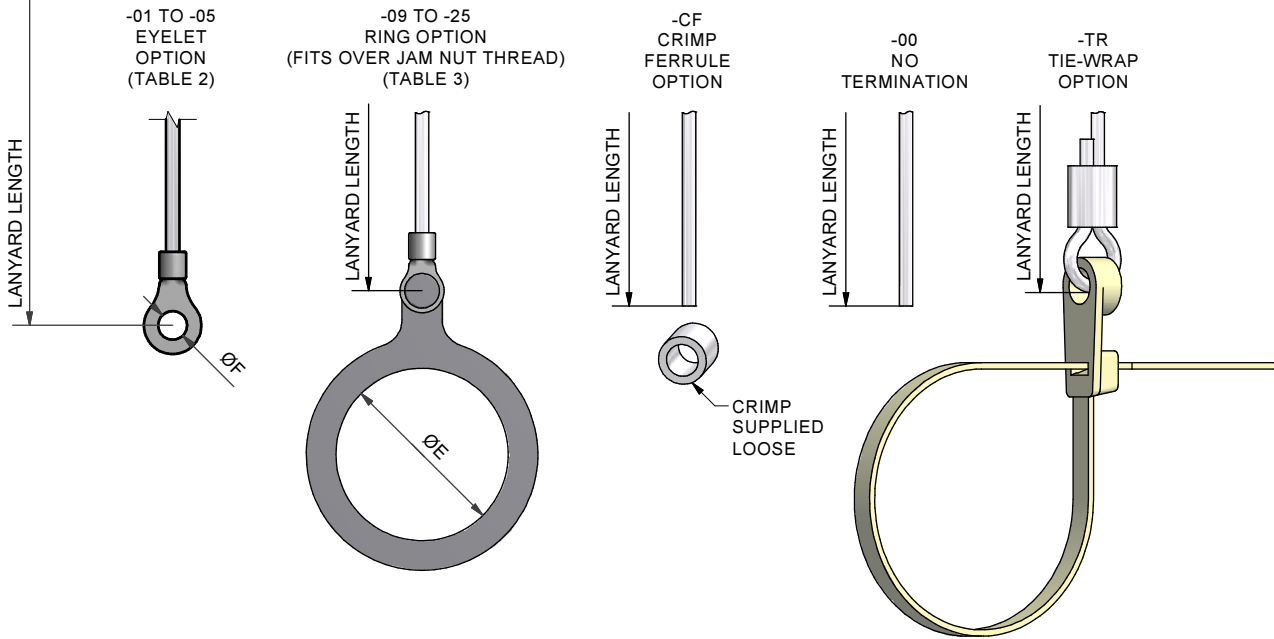

OMIT FOR NO ATTACHMENT
(SEE SHEET 2)

100P160-17-1-C-WR4-17

SERIES _____
 INSERT 'F' FOR _____
 FLUOROSILICONE GASKET
 OMIT FOR STANDARD
 SILICONE GASKET
 SHELL SIZE (TABLE 1) _____
 MATERIAL (TABLE 5) _____
 FINISH (TABLE 6) _____
 LANYARD TYPE (TABLE 4) _____
 LANYARD LENGTH (IN INCHES) _____
 +1,0"/-0" TOLERANCE
 ATTACHMENT (SEE ABOVE) _____

DRAWN	W.RUST	DATE 12/02/2014	3RD ANGLE PROJECTION NOT TO SCALE	POLAMCO WESTON LOCK LOWER BRISTOL ROAD BATH BA2 1EP	PAGE 1 OF 4	UNLESS OTHERWISE SPECIFIED ALL DIMENSIONS IN MILLIMETRES
SALES APPR						ASSY USED ON: MIL-DTL-38999 SERIES III
DESIGN APPR			THIS DRAWING IS COPYRIGHT AND THE PROPERTY OF POLAMCO LTD IT MUST NOT BE COPIED, USED FOR MANUFACTURE OR OTHERWISE DISCLOSED WITHOUT PRIOR WRITTEN CONSENT OF THE COMPANY.	TITLE: RECEPTACLE PROTECTION CAP	SEE TABLE 5	
QUAL APPR						NCAGE CODE U5792
ISSUE 9	REV 3	DCR 3969				PART NUMBER: 100P160 SERIES
WEIGHT	---	GENERAL TOL LINEAR +/-0.1MM ANGULAR +/-1°				

TABLE 1

SHELL SIZE	ØA MAX	B THREAD
09	21,0	0.625-0.1P-0.3L-TS
11	24,5	0.750-0.1P-0.3L-TS
13	28,0	0.875-0.1P-0.3L-TS
15	30,0	1.000-0.1P-0.3L-TS
17	34,0	1.1875-0.1P-0.3L-TS
19	37,0	1.250-0.1P-0.3L-TS
21	40,0	1.375-0.1P-0.3L-TS
23	43,0	1.500-0.1P-0.3L-TS
25	47,0	1.625-0.1P-0.3L-TS

TABLE 2

EYELET REF.	ØF
01	3,2
02	3,7
03	4,3
04	5,3
05	6,4

TABLE 3

RING REF.	ØE MAX
09	18,0
11	21,4
13	25,8
15	28,8
17	32,0
19	35,0
21	38,3
23	41,7
25	44,6

TABLE 4

CODE	LANYARD TYPE
WR	NYLON COVERED (CLEAR) STAINLESS STEEL WIRE ROPE
TC	TEFLON COVERED (CLEAR) STAINLESS STEEL WIRE ROPE
WG	TEFLON COVERED (OLIVE DRAB) STAINLESS STEEL WIRE ROPE
WB	TEFLON COVERED (BLACK) STAINLESS STEEL WIRE ROPE
WRB	PVC COVERED (BLACK) STAINLESS STEEL WIRE ROPE
LC	LINK CHAIN
BK	BLACK CORD
VGB	1,5mm BLACK POLYESTER CORD EQV. TO DIN83330-E1,5
B	BEAD CHAIN
R	OLIVE DRAB POLYESTER CORD
NB	OLIVE DRAB NYLON CORD
NK	BLACK NYLON CORD

TABLE 5

CODE	MATERIAL	GASKET MATERIAL
1	ALUMINIUM	SILICONE
2	NICKEL ALUMINIUM BRONZE	SILICONE
4	STAINLESS STEEL	VITON
7	BLACK ACETAL	SILICONE
74	COMPOSITE	SILICONE

LIST NOT EXHAUSTIVE, SEE MATERIAL TABLE FOR OTHER OPTIONS

TABLE 6

PLATING CODE	PLATING DESCRIPTION	ROHS COMPLIANT	ENVIRONMENT PROTECTION/ CONDUCTIVITY
B	CADMIUM, OLIVE DRAB (5-10 MICRONS) QQ-P-416, TYPE II, CLASS 3 OVER ELECTROLESS NICKEL	YES (SUBJECT TO EXEMPTION)	CONDUCTIVE 500 HRS SALT SPRAY. EXEMPTION APPLICABLE FOR AEROSPACE / MILITARY APPLICATIONS. SEE ROHS WEBSITES FOR MORE INFORMATION.
C	ELECTROLESS NICKEL, AMS-C-26074, CLASS 4, GRADE B	YES	CONDUCTIVE
J	PASSIVATE, PER QQ-P-35 OR MI-S-5002	YES	ROHS COMPLIANT
U	UNPLATED CLEAN FINISH NOT SHOT BLASTED	YES	CONDUCTIVE
Z	SHOT BLAST FOR NON-REFLECTIVE FINISH	YES	CONDUCTIVE
ZB	ZINC COBALT (5-10 MICRONS) OVER ELECTROLESS NICKEL (2,5-7,5 MICRONS) WITH A OLIVE DRAB CHROMATE CONVERSION	YES	CONDUCTIVE 350 HRS SALT SPRAY
ZN	ZINC NICKEL BLACK PASSIVATE (5-12 MICRONS) OVER ELECTROLESS NICKEL (8-12 MICRONS), ASTM B 841 CLASS 1	YES (SUBJECT TO TESTING)	ROHS COMPLIANT (SUBJECT TO TESTING)

LIST NOT EXHAUSTIVE, SEE PLATING TABLE FOR OTHER OPTIONS

WITHOUT ATTACHMENT



100P160-17-1-C
NO ATTACHMENT VERSION

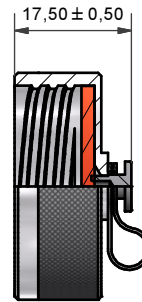

100P160-17-1-C-EO
EYELET ONLY VERSION
(NO LANYARD)

DRAWN	W.RUST	DATE 12/02/2014	3RD ANGLE PROJECTION NOT TO SCALE	POLAMCO WESTON LOCK LOWER BRISTOL ROAD BATH BA2 1EP	PAGE 2 OF 4	UNLESS OTHERWISE SPECIFIED ALL DIMENSIONS IN MILLIMETRES	
SALES APPR					ASSY USED ON: MIL-DTL-38999 SERIES III	MATERIAL SEE TABLE 5	
DESIGN APPR			THIS DRAWING IS COPYRIGHT AND THE PROPERTY OF POLAMCO LTD. IT MUST NOT BE COPIED, USED FOR MANUFACTURE OR OTHERWISE DISCLOSED WITHOUT PRIOR WRITTEN CONSENT OF THE COMPANY.	TITLE: RECEPTACLE PROTECTION CAP	NCAGE CODE U5792		
QUAL APPR						PART NUMBER: 100P160 SERIES	DRAWING NO: P10523
ISSUE 9	REV 3	DCR 3969					
WEIGHT	GENERAL TOL LINEAR +/-0.1MM ANGULAR +/-1°						

OPTIONAL GASKET:



OMIT FOR NO ATTACHMENT
(SEE SHEET 2)

100P160-17-1-C-WR4-17-EPDM

- SERIES _____
- SHELL SIZE (TABLE 1) _____
- MATERIAL (TABLE 5) _____
- FINISH (TABLE 6) _____
- LANYARD TYPE (TABLE 4) _____
- LANYARD LENGTH (IN INCHES) _____
- +1,0"/-0" TOLERANCE
- ATTACHMENT (SEE ABOVE) _____
- EPDM GASKET _____

DRAWN	W.RUST	DATE 12/02/2014	3RD ANGLE PROJECTION NOT TO SCALE	 POLAMCO WESTON LOCK LOWER BRISTOL ROAD BATH BA2 1EP	PAGE 3 OF 4	UNLESS OTHERWISE SPECIFIED ALL DIMENSIONS IN MILLIMETRES
SALES APPR			THIS DRAWING IS COPYRIGHT AND THE PROPERTY OF POLAMCO LTD IT MUST NOT BE COPIED, USED FOR MANUFACTURE OR OTHERWISE DISCLOSED WITHOUT PRIOR WRITTEN CONSENT OF THE COMPANY.	ASSY USED ON: MIL-DTL-38999 SERIES III		MATERIAL
DESIGN APPR				TITLE: RECEPTACLE PROTECTION CAP		SEE TABLE 5
QUAL APPR				PART NUMBER: 100P160 SERIES		NCAGE CODE U5792
ISSUE 9	REV 3	DCR 3969				DRAWING NO: P10523
WEIGHT ---	GENERAL TOL LINEAR +/-0.1MM ANGULAR +/-1°					

WITH PLATED ACCESSORIES



100P160-17-1-C2-WR4-17

SERIES _____
 SHELL SIZE (TABLE 1) _____
 MATERIAL (TABLE 5) _____
 FINISH (TABLE 6) _____
 PLATED EYELETS, RIVETS
 AND RINGS - AVAILABLE
 FOR PLATING CODES B, C, ZB, ZN
 (SEE NOTE)
 LANYARD TYPE (TABLE 4) _____
 LANYARD LENGTH (IN INCHES)
 +1,0"/-0" TOLERANCE _____
 ATTACHMENT (SEE ABOVE) _____

NOTE:
 1. ALL COMPONENTS INDICATED TO BE PLATED THE SAME AS CAP WHEN CODE "2" IS INSERTED IN THE PART NUMBER

DRAWN	W.RUST	DATE 12/02/2014	3RD ANGLE PROJECTION NOT TO SCALE		WESTON LOCK LOWER BRISTOL ROAD BATH BA2 1EP	PAGE 4 OF 4	UNLESS OTHERWISE SPECIFIED ALL DIMENSIONS IN MILLIMETRES
SALES APPR							
DESIGN APPR			THIS DRAWING IS COPYRIGHT AND THE PROPERTY OF POLAMCO LTD IT MUST NOT BE COPIED, USED FOR MANUFACTURE OR OTHERWISE DISCLOSED WITHOUT PRIOR WRITTEN CONSENT OF THE COMPANY.	ASSY USED ON: MIL-DTL-38999 SERIES III			MATERIAL
QUAL APPR				TITLE: RECEPTACLE PROTECTION CAP			SEE TABLE 5
ISSUE 9	REV 3	DCR 3969		PART NUMBER: 100P160 SERIES			NCAGE CODE U5792
WEIGHT ---	GENERAL TOL LINEAR +/-0.1MM ANGULAR +/-1°						DRAWING NO: P10523

Компания «Life Electronics» занимается поставками электронных компонентов импортного и отечественного производства от производителей и со складов крупных дистрибьюторов Европы, Америки и Азии.

С конца 2013 года компания активно расширяет линейку поставок компонентов по направлению коаксиальный кабель, кварцевые генераторы и конденсаторы (керамические, пленочные, электролитические), за счёт заключения дистрибьюторских договоров

Мы предлагаем:

- Конкурентоспособные цены и скидки постоянным клиентам.
- Специальные условия для постоянных клиентов.
- Подбор аналогов.
- Поставку компонентов в любых объемах, удовлетворяющих вашим потребностям.
- Приемлемые сроки поставки, возможна ускоренная поставка.
- Доставку товара в любую точку России и стран СНГ.
- Комплексную поставку.
- Работу по проектам и поставку образцов.
- Формирование склада под заказчика.
- Сертификаты соответствия на поставляемую продукцию (по желанию клиента).
- Тестирование поставляемой продукции.
- Поставку компонентов, требующих военную и космическую приемку.
- Входной контроль качества.
- Наличие сертификата ISO.

В составе нашей компании организован Конструкторский отдел, призванный помогать разработчикам, и инженерам.

Конструкторский отдел помогает осуществить:

- Регистрацию проекта у производителя компонентов.
- Техническую поддержку проекта.
- Защиту от снятия компонента с производства.
- Оценку стоимости проекта по компонентам.
- Изготовление тестовой платы монтаж и пусконаладочные работы.



Тел: +7 (812) 336 43 04 (многоканальный)
Email: org@lifeelectronics.ru