



FEATURES

- High efficiency:
 - 92.8% @ 12Vin, 3.3V/30A out
 - 89.5% @ 12Vin, 1.8V/30A out
 - 85.5% @ 12Vin, 1.2V/30A out
 - 80.5% @ 12Vin, 0.8V/30A out
- Small size and low profile: 33.0mm x 13.5mm x 10.0mm
- Surface mount packaging
- Standard footprint
- Voltage and resistor-based trim
- Pre-bias startup
- Output voltage tracking
- No minimum load required
- Output voltage programmable from 0.8Vdc to 3.3 Vdc via external resistor
- Fixed frequency operation
- Input UVLO, Output OCP
- Remote on/off
- Remote sense
- Option- Parallel operation
- ISO 9001, TL 9000, ISO 14001, QS9000, OHSAS18001 certified manufacturing facility
UL/cUL 60950-1 (US & Canada)
CE mark meets 73/23/EEC and 93/68/EEC directives

Delphi DCL, Non-Isolated Point of Load DC/DC Power Modules: 6~14Vin, 0.8V-3.3V/30Aout

The Delphi Series DCK, 6-14V input, single output, non-isolated Point of Load DC/DC converters are the latest offering from a world leader in power systems technology and manufacturing -- Delta Electronics, Inc. The DCK series provides a programmable output voltage from 0.8 V to 3.3 V using an external resistor and has flexible and programmable tracking features to enable a variety of startup voltages as well as tracking between power modules. This product family is available in surface mount and provides up to 30A of output current in an industry standard footprint. With creative design technology and optimization of component placement, these converters possess outstanding electrical and thermal performance, as well as extremely high reliability under highly stressful operating conditions.

OPTIONS

- Negative/Positive on/off logic
- Vo Tracking feature

APPLICATIONS

- Telecom / DataCom
- Distributed power architectures
- Servers and workstations
- LAN / WAN applications
- Data processing applications

TECHNICAL SPECIFICATIONS

($T_A = 25^\circ\text{C}$, airflow rate = 300 LFM, $V_{in} = 6\text{Vdc}$ and 14.0Vdc , nominal V_{out} unless otherwise noted.)

PARAMETER	NOTES and CONDITIONS	DCK12S0A0S30NFA			
		Min.	Typ.	Max.	Units
ABSOLUTE MAXIMUM RATINGS					
Input Voltage (Continuous)		-0.3		15	V
Sequencing Voltage		-0.3		$V_{in\ max}$	V
Operating Ambient Temperature		-40		85	$^\circ\text{C}$
Storage Temperature		-55		125	$^\circ\text{C}$
INPUT CHARACTERISTICS					
Operating Input Voltage	Output Voltage is 0.8V~2.0V	6	12	14	V
Operating Input Voltage	Output Voltage is 2.0V~3.3V	10	12	14	V
Input Under-Voltage Lockout					
Turn-On Voltage Threshold			5.4		V
Turn-Off Voltage Threshold			5.0		V
Lockout Hysteresis Voltage			0.4		V
Maximum Input Current	$V_{in}=6\text{V to }14\text{V}$, $I_o=I_o,max$			19	A
No-Load Input Current ($I_o = 0$, module enabled)	$V_{in}= 12\text{V}$, $V_o,set = 0.8\text{ Vdc}$		180		mA
	$V_{in}= 12\text{V}$, $V_o,set = 3.3\text{ Vdc}$		280		mA
Off Converter Input Current	($V_{IN} = 12.0\text{Vdc}$, module disabled)			30	mA
Inrush Transient				1	A2S
Input Reflected Ripple Current, peak-to-peak	(5Hz to 20MHz, 1 μH source impedance; $V_{in} = 0$ to 14V, $I_o=I_o,max$;		100		mA _{p-p}
OUTPUT CHARACTERISTICS					
Output Voltage Set Point	with 0.5% tolerance for external resistor used to set output voltage)	-1.5	V_o,set	+1.5	% V_o,set
Output Voltage Adjustable Range	(selected by an external resistor)	0.8		3.3	V
Output Voltage Regulation					
Line($V_{IN}=V_{IN}$, min to V_{IN} , max)				+/-10	mV
Load($I_o=I_o$, min to I_o , max)				+/-10	mV
Temperature($T_{ref}=T_A$, min to T_A , max)			0.5	1	% V_o,set
Total Output Voltage Range	Over sample load, line and temperature	-2.5		+2.5	% V_o,set
Output Voltage Ripple and Noise	5Hz to 20MHz bandwidth				
Peak-to-Peak	$V_{in}= V_{in\ nominal}$, $I_o=I_o,min$ to I_o,max , $C_o= 1\mu\text{F}+10\mu\text{F}$ ceramic,			75	mV
RMS	$V_{in}= V_{in\ nominal}$, $I_o=I_o,min$ to I_o,max , $C_o= 1\mu\text{F}+10\mu\text{F}$ ceramic,			25	mV
Output Current Range		0		30	A
Output Voltage Over-shoot at Start-up				5	% V_o,set
Output DC Current-Limit Inception			200		% I_o
DYNAMIC CHARACTERISTICS					
Dynamic Load Response	10 μF Tan & 1 μF Ceramic load cap, 2.5A/ μs				
Positive Step Change in Output Current	50% I_o , max to 100% I_o , max		300		mV
Negative Step Change in Output Current	100% I_o , max to 50% I_o , max		300		mV
Settling Time(within 1.5% V_{out} normal)			50		μs
Turn-On Transient	$I_o=I_o,max$				
Start-Up Time, From On/Off Control	Time for $V_{on/off}$ to $V_o=10\%$ of V_o,set		2		ms
Start-Up Time, From Input	Time for $V_{in}=V_{in,min}$ to $V_o=10\%$ of V_o,set		2		ms
Output Voltage Rise Time	Time for V_o to rise from 10% to 90% of V_o,set		1		ms
Output Capacitive Load	Full load; $ESR \geq 0.15\text{m}\Omega$			1000	μF
EFFICIENCY					
$V_o=3.3\text{V}$	$V_{in}=12\text{V}$, 100% Load		92.8		%
$V_o=1.8\text{V}$	$V_{in}=12\text{V}$, 100% Load		89.5		%
$V_o=1.2\text{V}$	$V_{in}=12\text{V}$, 100% Load		85.5		%
$V_o=0.8\text{V}$	$V_{in}=12\text{V}$, 100% Load		80.5		%
FEATURE CHARACTERISTICS					
Switching Frequency			370		kHz
ON/OFF Control, (Logic High, Module off)					
Input High Current				300	μA
Input High Voltage		3		$V_{in,max}$	V
ON/OFF Control, (Logic Low, Module on)					
Input Low Current				20	μA
Input Low Voltage		-0.3		0.7	V
Tracking Slew Rate Capability				0.5	V/msec
Tracking Delay Time	Delay from $V_{in,min}$ to application of tracking voltage	10			ms
Tracking Accuracy	Power-up 2V/mS		100	200	mV
	Power-down 1V/mS		200	400	mV
Forced Load Share Accuracy	*Option for code B (current sharing)	-	10		% I_o
Number of units in Parallel	*Option for code B (current sharing)			2	unit
GENERAL SPECIFICATIONS					
MTBF	$I_o=80\%$ of I_o,max ; $T_a=25^\circ\text{C}$	2			M hours
Weight			6.9		grams

ELECTRICAL CHARACTERISTICS CURVES

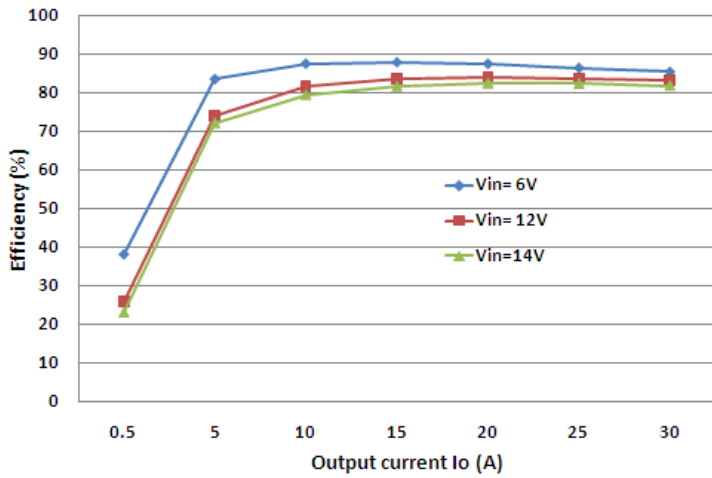

Figure 1: Converter efficiency vs. output current (Vout= 0.8V)

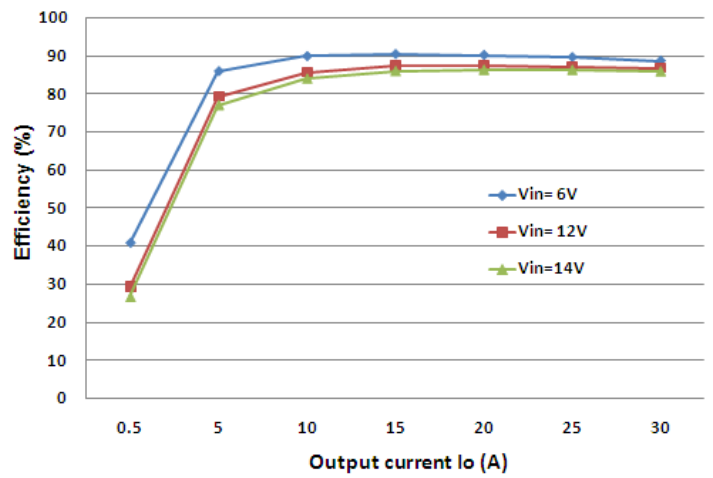

Figure 2: Converter efficiency vs. output current (1.2V out)

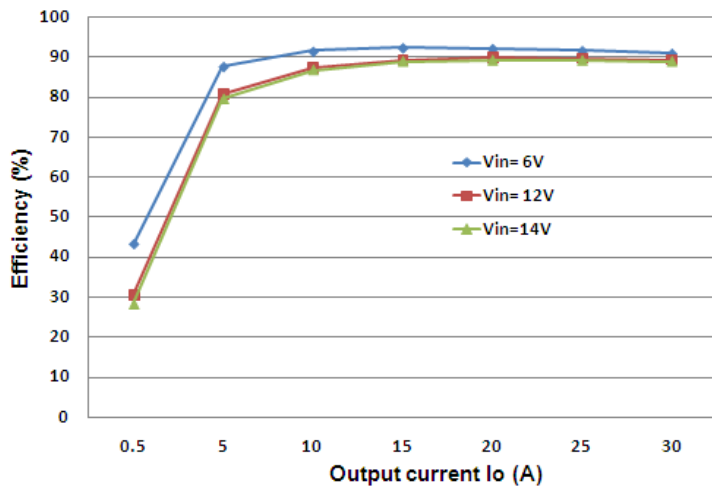

Figure 3: Converter efficiency vs. output current (1.8V out)

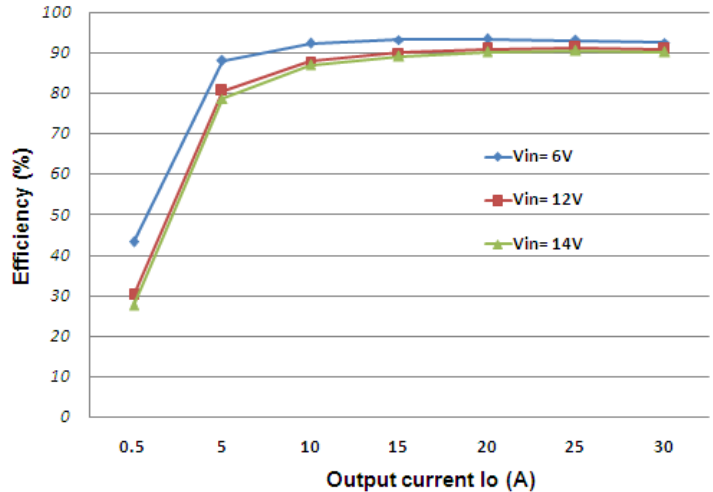

Figure 4: Converter efficiency vs. output current (2.5V out)

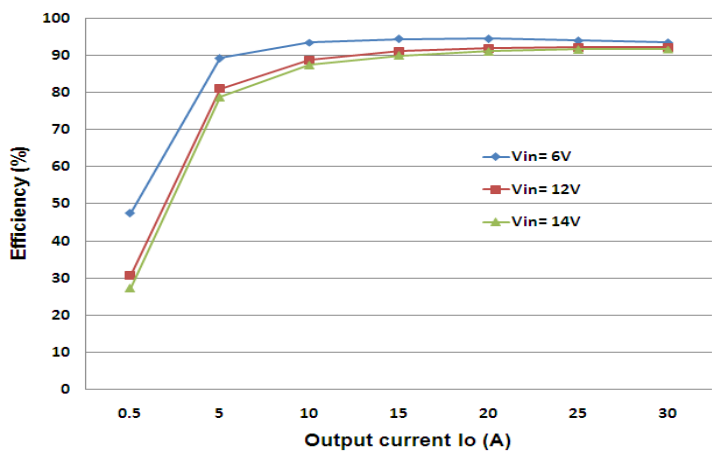

Figure 5: Converter efficiency vs. output current 3.3V out)

ELECTRICAL CHARACTERISTICS CURVES (CON.)

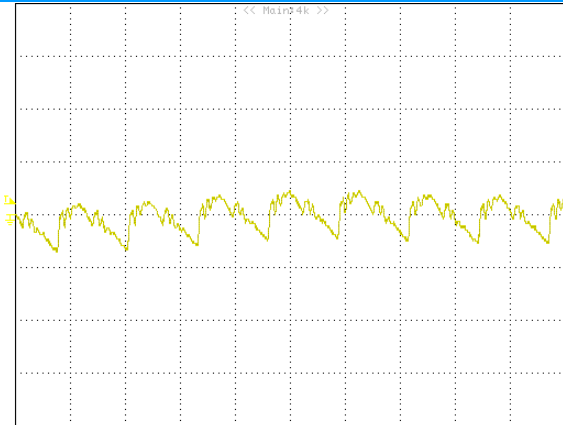

Figure 6: Output ripple & noise at 12Vin, 0.8V/30A out
CH1:VOUT, 20mV/div, 2uS/div

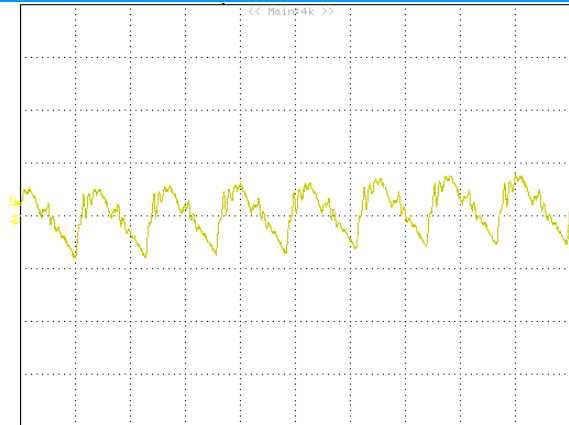

Figure 7: Output ripple & noise at 12Vin, 1.2V/30A out
CH1:VOUT, 20mV/div, 2uS/div

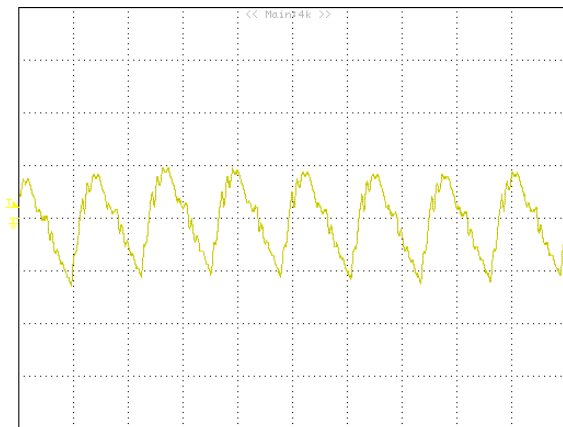

Figure 8: Output ripple & noise at 12Vin, 1.8V/30A out
CH1:VOUT, 20mV/div, 2uS/div

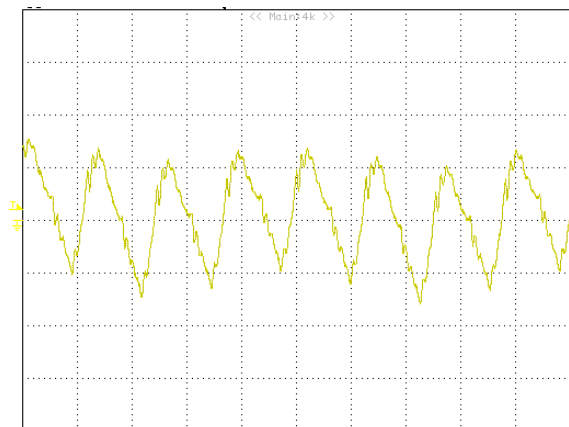

Figure 9: Output ripple & noise at 12Vin, 2.5V/30A out
CH1:VOUT, 20mV/div, 2uS/div

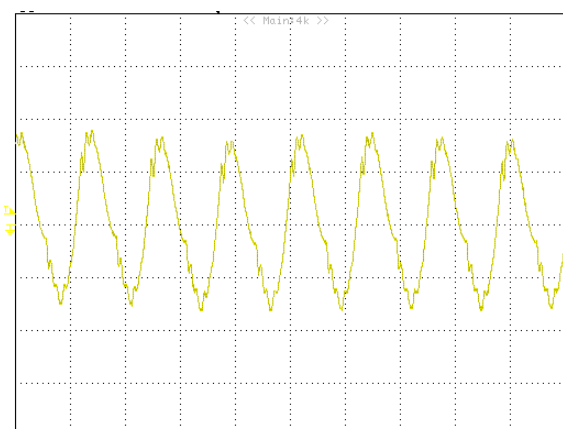

Figure 10: Output ripple & noise at 12Vin, 3.3V/30A out
CH1:VOUT, 20mV/div, 2uS/div

ELECTRICAL CHARACTERISTICS CURVES (CON.)



Figure 11: Turn on delay time at 12Vin, 0.8V/30A out.
(Green : VOUT, 0.5V/div, Yellow: VIN, 5V/div. 1mS/div)

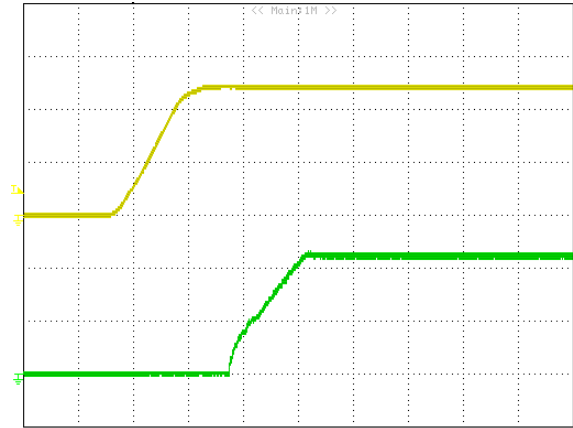

Figure 12: Turn on delay time at 12Vin, 1.2V/30A out.
(Green : VOUT, 0.5V/div, Yellow: VIN, 5V/div. 1mS/div)



Figure 13: Turn on delay time at 12Vin, 1.8V/30A out.
(Green : VOUT, 0.5V/div, Yellow: VIN, 5V/div. 1mS/div)

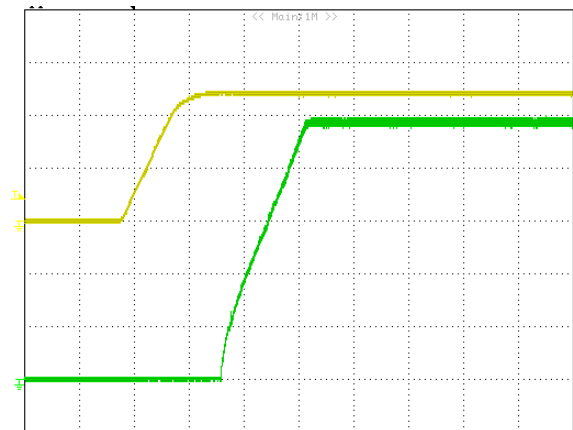

Figure 14: Turn on delay time at 12Vin, 2.5V/30A out.
(Green : VOUT, 0.5V/div, Yellow: VIN, 5V/div. 1mS/div)

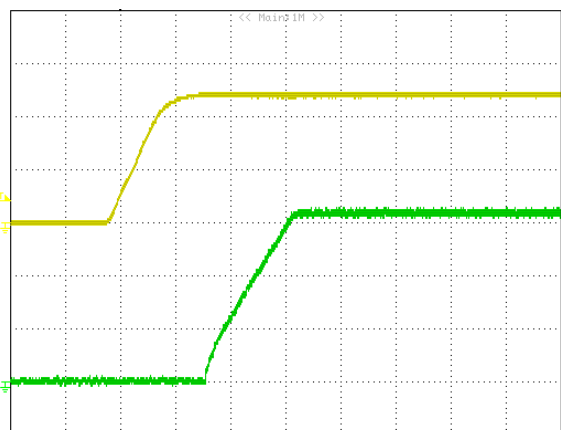

Figure 15: Turn on delay time at 12Vin, 3.3V/30A out.
(Green : VOUT, 1V/div, Yellow: VIN, 5V/div. 2mS/div)

ELECTRICAL CHARACTERISTICS CURVES (CON.)

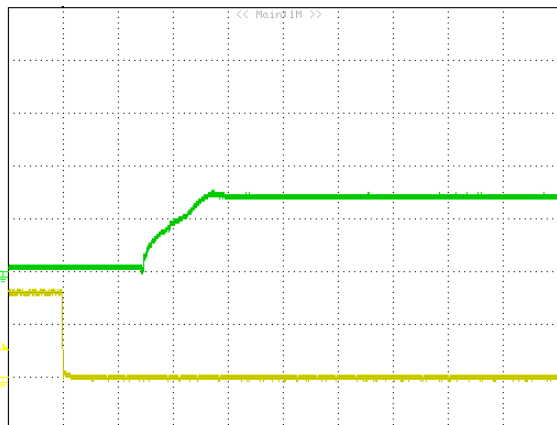

Figure 16: Turn on delay time at remote on 12Vin, 0.8V/30A out.
(Green: VOUT, 0.5V/div, Yellow: ON/OFF, 2V/div, 1mS/div)

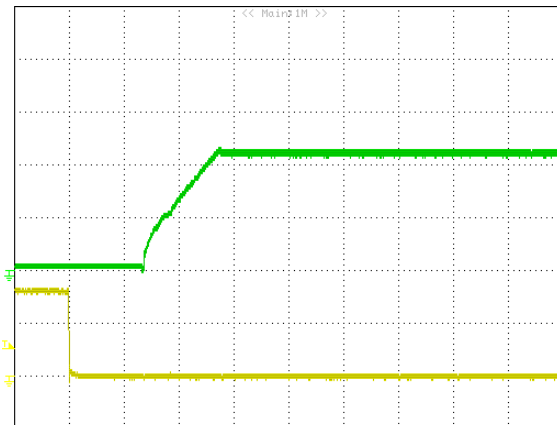

Figure17: Turn on delay time at remote on 12Vin, 1.2V/30A out.
(Green: VOUT, 0.5V/div, Yellow: ON/OFF, 2V/div, 1mS/div)

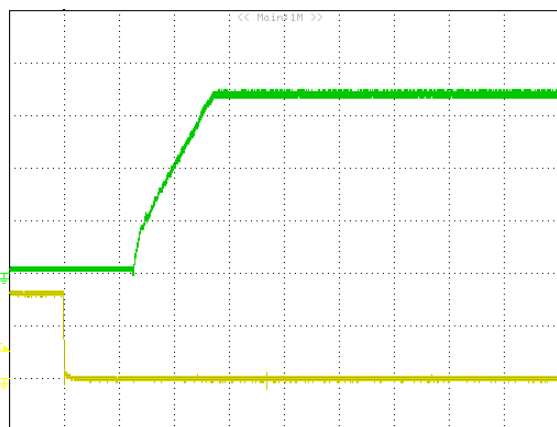

Figure 18: Turn on delay time at remote on 12Vin, 1.8V/30A out.
(Green: VOUT, 0.5V/div, Yellow: ON/OFF, 2V/div, 1mS/div)



Figure 19: Turn on delay time at remote on 12Vin, 2.5V/30A out.
(Green: VOUT, 1V/div, Yellow: ON/OFF, 2V/div, 1mS/div)

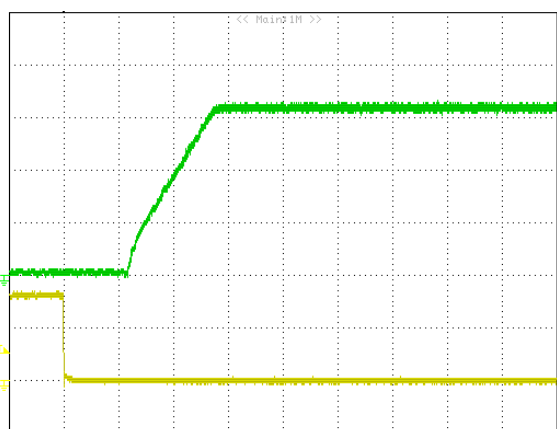

Figure 20: Turn on delay time at remote on 12Vin, 3.3V/30A out.
(Green: VOUT, 1V/div, Yellow: ON/OFF, 2V/div, 1mS/div)

ELECTRICAL CHARACTERISTICS CURVES

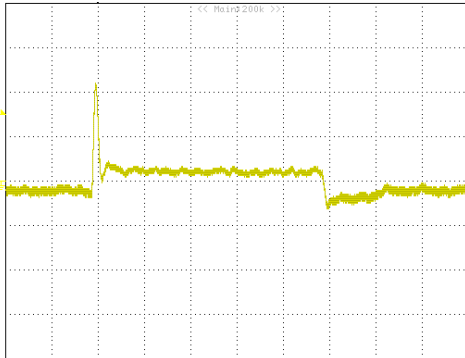

Figure 21: Transient response to dynamic load change at $2.5A/\mu S$ from 50%~ 100%~50% of I_o , max at 12Vin, 0.8Vout (Cout = 1uF ceramic, 47uF*2 +10uF ceramic)
Yellow : VOUT, 0.2V/div, 100uS/div

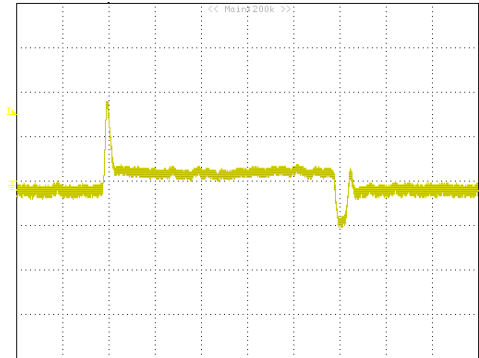

Figure 22: Transient response to dynamic load change at $2.5A/\mu S$ from 50%~ 100%~50% of I_o , max at 12Vin, 1.2Vout (Cout = 1uF ceramic, 47uF*2 +10uF ceramic)
Yellow : VOUT, 0.2V/div, 100uS/div

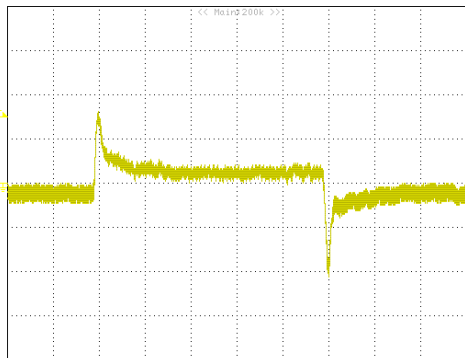

Figure 23: Transient response to dynamic load change at $2.5A/\mu S$ from 50%~ 100%~50% of I_o , max at 12Vin, 1.8Vout (Cout = 1uF ceramic, 47uF*2 +10uF ceramic)
Yellow : VOUT, 0.1V/div, 100uS/div

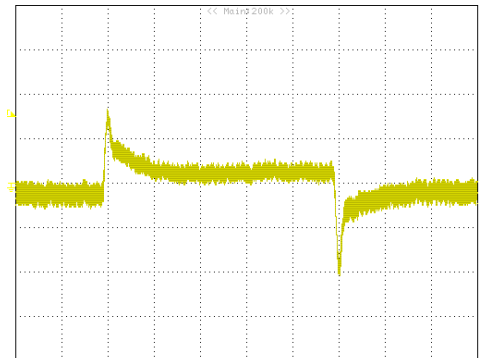

Figure 24: Transient response to dynamic load change at $2.5A/\mu S$ from 50%~ 100%~50% of I_o , max at 12Vin, 2.5Vout (Cout = 1uF ceramic, 47uF*2 +10uF ceramic)
Yellow : VOUT, 0.1V/div, 100uS/div

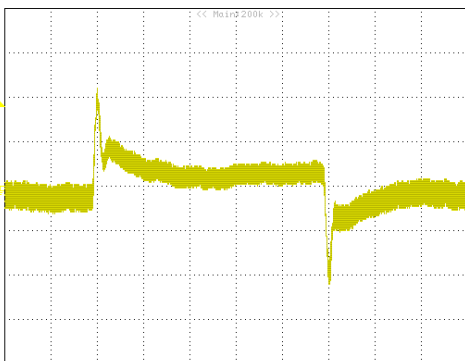

Figure 25: Transient response to dynamic load change at $2.5A/\mu S$ from 50%~ 100%~50% of I_o , max at 12Vin, 3.3Vout (Cout = 1uF ceramic, 47uF*2 +10uF ceramic)
Yellow : VOUT, 0.1V/div, 100uS/div

ELECTRICAL CHARACTERISTICS CURVES (CON.)

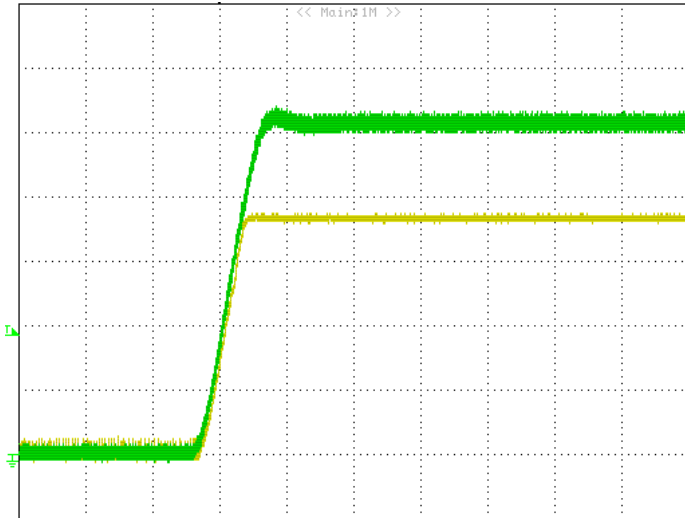

Figure 26:Tracking function, $V_{tracking}=1V$, $V_{out}= 0.8V$, full load
Yellow : VOUT, (0.2V/div), Green: Tracking, (0.2V/div), 2mS/div

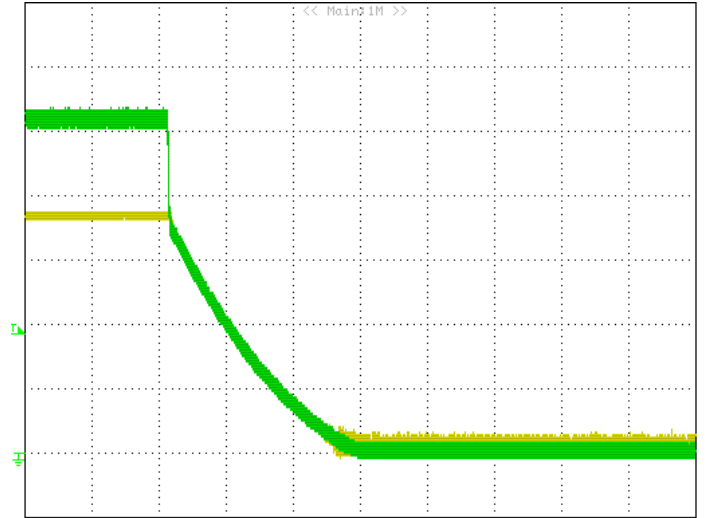

Figure 27:Tracking function, $V_{tracking}=1V$, $V_{out}= 0.8V$, full load
Yellow : VOUT, (0.2V/div), Green: Tracking, (0.2V/div), 20mS/div

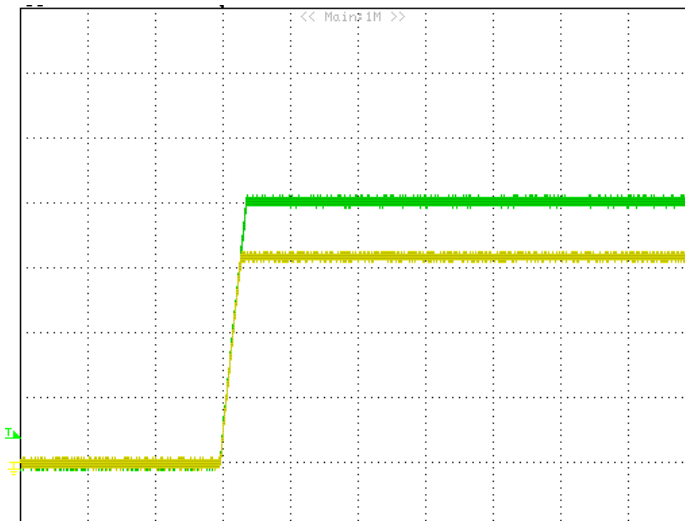

Figure 28:Tracking function, $V_{tracking}=4V$, $V_{out}= 3.3V$, full load
Yellow: VOUT, 1V/div, Green : Tracking, 1V/div, 20mS/div

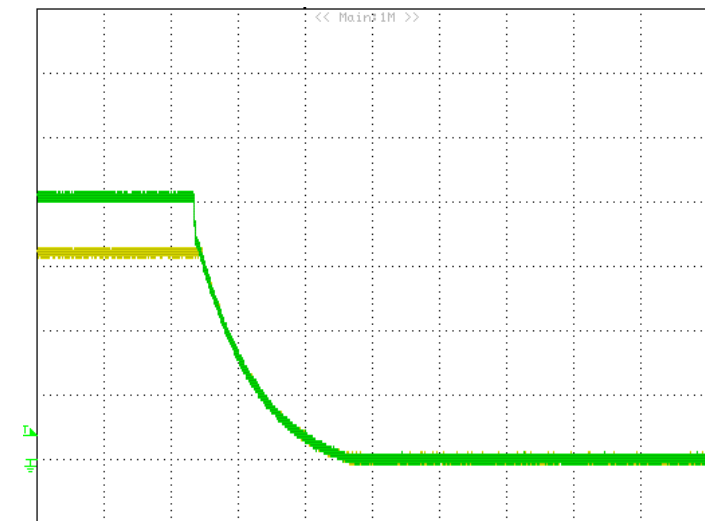
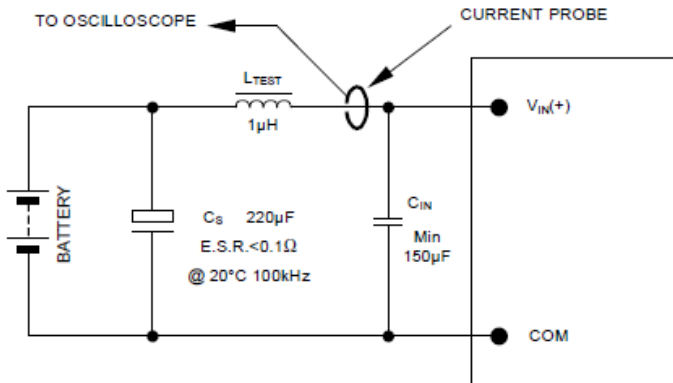

Figure 29:Tracking function, $V_{tracking}=4V$, $V_{out}= 3.3V$, full load
Yellow: VOUT, 1V/div, Green : Tracking, 1V/div, 20mS/div

TEST CONFIGURATIONS



NOTE: Measure input reflected ripple current with a simulated source inductance (L_{TEST}) of $1\mu\text{H}$. Capacitor C_s offsets possible battery impedance. Measure current as shown above.

Figure 30: Input reflected-ripple current test setup

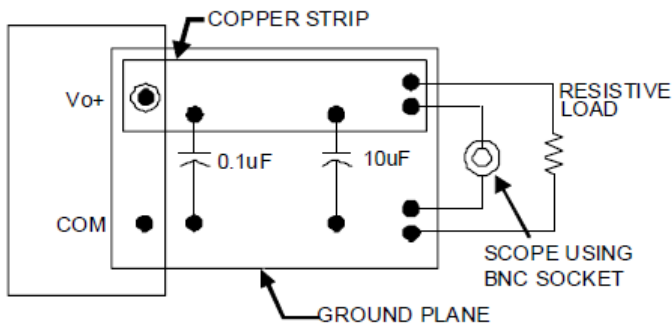

Note: Use a $10\mu\text{F}$ and $1\mu\text{F}$ capacitor. Scope measurement should be made using a BNC connector.

Figure 31: Peak-peak output noise and startup transient measurement test setup.

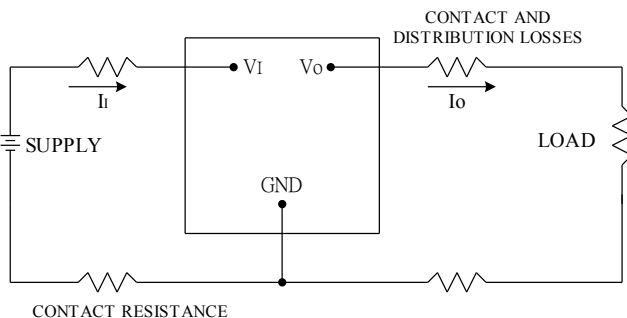

Figure 32: Output voltage and efficiency measurement test setup

Note: All measurements are taken at the module terminals. When the module is not soldered (via socket), place Kelvin connections at module terminals to avoid measurement errors due to contact resistance.

$$\eta = \left(\frac{V_o \times I_o}{V_i \times I_i} \right) \times 100 \quad \%$$

DESIGN CONSIDERATIONS

Input Source Impedance

To maintain low noise and ripple at the input voltage, it is critical to use low ESR capacitors at the input to the module. A highly inductive source can affect the stability of the module. An input capacitance must be placed close to the modules input pins to filter ripple current and ensure module stability in the presence of inductive traces that supply the input voltage to the module.

Safety Considerations

For safety-agency approval the power module must be installed in compliance with the spacing and separation requirements of the end-use safety agency standards.

For the converter output to be considered meeting the requirements of safety extra-low voltage (SELV), the input must meet SELV requirements. The power module has extra-low voltage (ELV) outputs when all inputs are ELV.

The input to these units is to be provided with a fast acting fuse with a maximum rating of 30A in the positive input lead.

FEATURES DESCRIPTIONS

Remote On/Off

The DCK series power modules have an On/Off pin for remote On/Off operation. Both positive and negative On/Off logic options are available in the DCK series power modules.

For positive logic module, connect an open collector (NPN) transistor or open drain (N channel) MOSFET between the On/Off pin and the GND pin (see figure 33). Positive logic On/Off signal turns the module ON during the logic high and turns the module OFF during the logic low. When the positive On/Off function is not used, leave the pin floating or tie to V_{in} (module will be On).

For negative logic module, the On/Off pin is pulled high with an external pull-up 5k Ω resistor (see figure 34). Negative logic On/Off signal turns the module OFF during logic high and turns the module ON during logic low. If the negative On/Off function is not used, leave the pin floating or tie to GND. (module will be on)

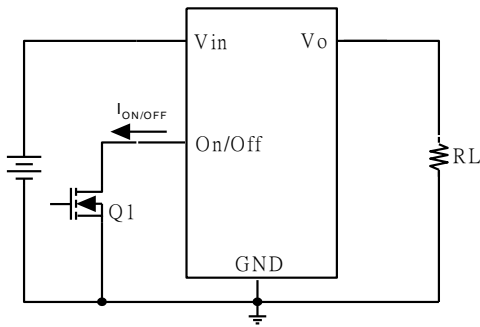

Figure 33: Positive remote On/Off implementation

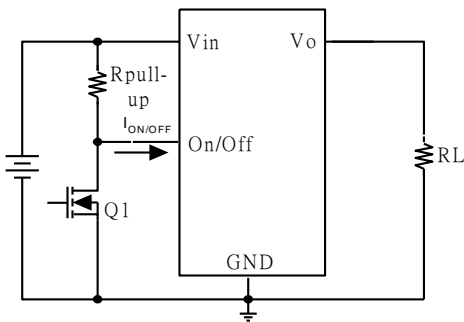

Figure 34: Negative remote On/Off implementation

Input Under voltage Lockout

At input voltages below the input under voltage lockout limit, the module operation is disabled. The module will begin to operate at an input voltage above the under voltage lockout turn-on threshold.

Over-Current Protection

To provide protection in an output over load fault condition, the unit is equipped with internal over-current protection. When the over-current protection is triggered, the unit enters hiccup mode. The units operate normally once the fault condition is removed.

Remote Sense

The DCK series provide V_o remote sensing to achieve proper regulation at the load points and reduce effects of distribution losses on output line. In the event of an open remote sense line, the module shall maintain local sense regulation through an internal resistor. The module shall correct for a total of 0.5V of loss. The remote sense line impedance shall be < 10 Ω .

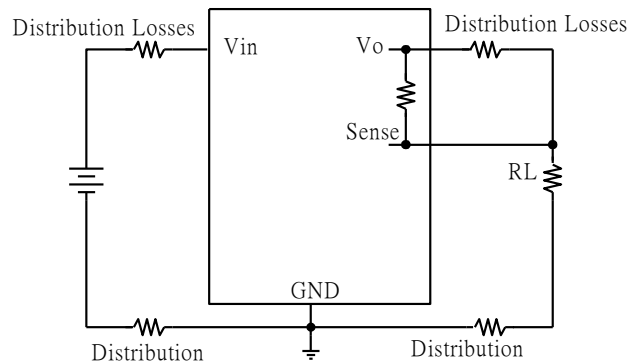

Figure 35: Effective circuit configuration for remote sense operation

FEATURES DESCRIPTIONS (CON.)

Output Voltage Programming

The output voltage of the DCK can be programmed to any voltage between 0.8Vdc and 3.3Vdc by connecting one resistor (shown as R_{trim} in Figure 36) between the TRIM and GND pins of the module. Without this external resistor, the output voltage of the module is 0.8 Vdc. To calculate the value of the resistor R_{trim} for a particular output voltage V_o , please use the following equation:

$$R_{trim} = \left[\frac{8000}{V_o - 0.8} \right] \Omega$$

R_{trim} is the external resistor in Ω

V_o is the desired output voltage.

For example, to program the output voltage of the DCK module to 3.3Vdc, R_{trim} is calculated as follows:

$$R_{trim} = \left[\frac{8000}{3.3 - 0.8} \right] \Omega = 3,200\Omega$$

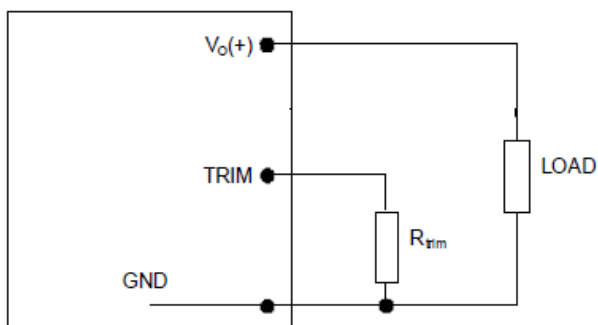

Figure 36: Circuit configuration for programming output voltage using an external resistor.

Table 1 provides R_{trim} values required for some common output voltages. By using a $\pm 0.5\%$ tolerance trim resistor with a TC of $\pm 100\text{ppm}$, a set point tolerance of $\pm 1.5\%$ can be achieved as specified in the electrical specification.

Table 1

$V_{O, set}$ (V)	R_{trim} (K Ω)
0.8	Open
1.0	40
1.2	20
1.5	11.429
1.8	8
2.5	4.706
3.3	3.2

FEATURE DESCRIPTIONS (CON.)

Voltage Margining

Output voltage margining can be implemented in the DCK modules by connecting a resistor, Rmargin-up, from the Trim pin to the ground pin for margining-up the output voltage and by connecting a resistor, Rmargin-down, from the Trim pin to the output pin for margining-down. Figure 37 shows the circuit configuration for output voltage margining. If unused, leave the trim pin unconnected. A calculation tool is available from the evaluation procedure which computes the values of Rmargin-up and Rmargin-down for a specific output voltage and margin percentage.

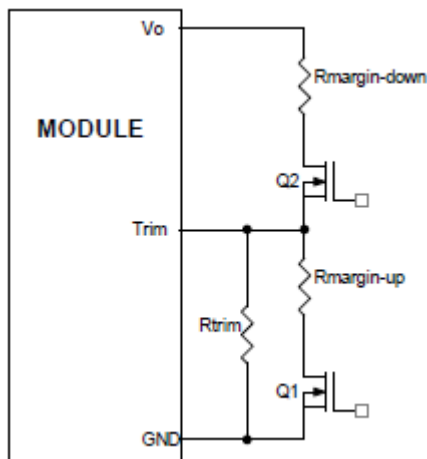

Figure 37: Circuit configuration for output voltage margining

Output Voltage Sequencing

The DCK 12V 30A modules include a sequencing feature that enables users to implement various types of output voltage sequencing in their applications. This is accomplished via an additional sequencing pin. When not using the sequencing feature, either tie the SEQ pin to VIN or leave it unconnected.

When an analog voltage is applied to the SEQ pin, the output voltage tracks this voltage until the output reaches the set-point voltage. The final value of the SEQ voltage must be set higher than the set-point voltage of the module. The output voltage follows the voltage on the SEQ pin on a one-to-one basis. By connecting multiple modules together, multiple modules can track their output voltages to the voltage applied on the SEQ pin.

For proper voltage sequencing, first, input voltage is applied to the module. The On/Off pin of the module is left unconnected (or tied to GND for negative logic modules or tied to VIN for positive logic modules) so that the module is ON by default. After applying input voltage to the module, a minimum 10msec delay is required before applying voltage on the SEQ pin. This delay gives the module enough time to complete its internal power-up soft-start cycle. During the delay time, the SEQ pin should be held close to ground (nominally 50mV ± 20 mV). This is required to keep the internal op-amp out of saturation thus preventing output overshoot during the start of the sequencing ramp. By selecting resistor R1 (see Figure. 39) according to the following equation

$$R1 = \left[\frac{24950}{V_{in} - 0.05} \right] \Omega$$

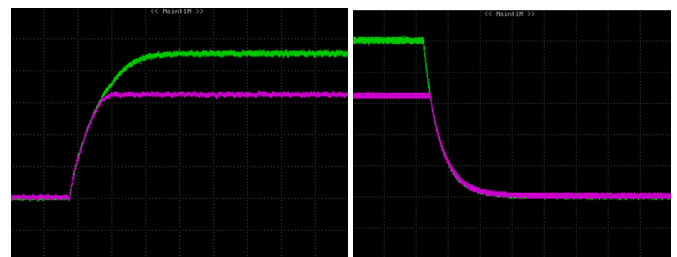

Figure 38: Sequential Start-up

The voltage at the sequencing pin will be 50mV when the sequencing signal is at zero.

FEATURE DESCRIPTIONS (CON.)

After the 10msec delay, an analog voltage is applied to the SEQ pin and the output voltage of the module will track this voltage on a one-to-one volt bases until the output reaches the set-point voltage. To initiate simultaneous shutdown of the modules, the SEQ pin voltage is lowered in a controlled manner. The output voltage of the modules tracks the voltages below their set-point voltages on a one-to-one basis. A valid input voltage must be maintained until the tracking and output voltages reach ground potential.

When using the sequencing feature to control start-up of the module, pre-bias immunity during startup is disabled. The pre-bias immunity feature of the module relies on the module being in the diode-mode during start-up. When using the sequencing feature, modules goes through an internal set-up time of 10msec, and will be in synchronous rectification mode when the voltage at the SEQ pin is applied. This will result in the module sinking current if a pre-bias voltage is present at the output of the module.

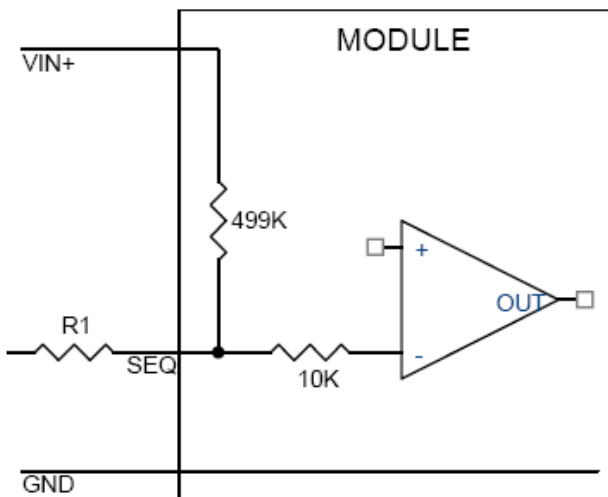

Figure 39: Circuit showing connection of the sequencing signal to the SEQ pin.

Monotonic Start-up and Shutdown

The DCK 30A modules have monotonic start-up and shutdown behavior for any combination of rated input voltage, output current and operating temperature range.

Active Load Sharing (-P Option)

For additional power requirements, The DCK 12V 30A modules is also available with a parallel option. Up to two modules can be configured, in parallel, with active load sharing.

Good layout techniques should be observed when using multiple units in parallel. To implement forced load sharing, the following connections should be made:

- The share pins of all units in parallel must be connected together. The path of these connections should be as direct as possible.
- All remote-sense pins should be connected to the power bus at the same point, i.e., connect all the SENSE(+) pins to the (+) side of the bus. Close proximity and directness are necessary for good noise immunity

Some special considerations apply for design of converters in parallel operation:

- When sizing the number of modules required for parallel operation, take note of the fact that current sharing has some tolerance. In addition, under transient conditions such as a dynamic load change and during startup, all converter output currents will not be equal. To allow for such variation and avoid the likelihood of a converter shutting off due to a current overload, we suggest that the total capacity of the paralleled system should be no more than 50% of the sum of the individual converters during startup. And we suggest the total capacity of the paralleled system should be no more than 90% of the sum of the individual converters after startup. As an example, for a system of two DCK 30A modules in parallel, the total current drawn should be less than 30A during startup. And the total current drawn should be less than 54A after startup.



- All modules should be turned on and off together. This is so that all modules come up at the same time avoiding the problem of one converter sourcing current into the other leading to an overcurrent trip condition. To ensure that all modules come up simultaneously, the on/off pins of all paralleled converters should be tied together and the converters enabled and disabled using the on/off pin.

- The share bus is not designed for redundant operation and the system will be non-functional upon failure of one of the unit when multiple units are in parallel. In particular, if one of the converters shuts down during operation, the other converters may also shut down due to their outputs hitting current limit. In such a situation, unless a coordinated restart is ensured, the system may never properly restart since different converters will try to restart at different times causing an overload condition and subsequent shutdown. This situation can be avoided by having an external output voltage monitor circuit that detects a shutdown condition and forces all converters to shut down and restart together.

- When not using the active load sharing feature, share pins should be left unconnected.

THERMAL CONSIDERATIONS

Thermal management is an important part of the system design. To ensure proper, reliable operation, sufficient cooling of the power module is needed over the entire temperature range of the module. Convection cooling is usually the dominant mode of heat transfer.

Hence, the choice of equipment to characterize the thermal performance of the power module is a wind tunnel.

Thermal Testing Setup

Delta's DC/DC power modules are characterized in heated vertical wind tunnels that simulate the thermal environments encountered in most electronics equipment. This type of equipment commonly uses vertically mounted circuit cards in cabinet racks in which the power modules are mounted.

The following figure 40 shows the wind tunnel characterization setup. The power module is mounted on a test PWB and is vertically positioned within the wind tunnel.

Thermal Derating

Heat can be removed by increasing airflow over the module. To enhance system reliability, the power module should always be operated below the maximum operating temperature. If the temperature exceeds the maximum module temperature, reliability of the unit may be affected.

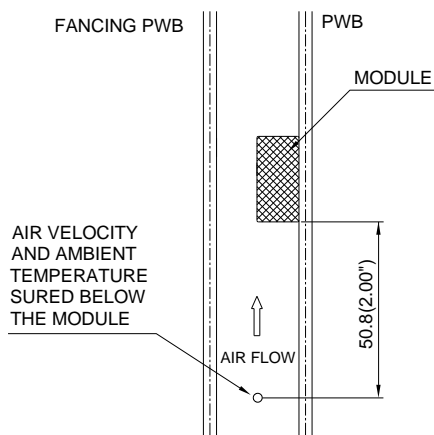

Note: Wind Tunnel Test Setup Figure Dimensions are in millimeters and (Inches)

Figure 40: Wind tunnel test setup

THERMAL CURVES

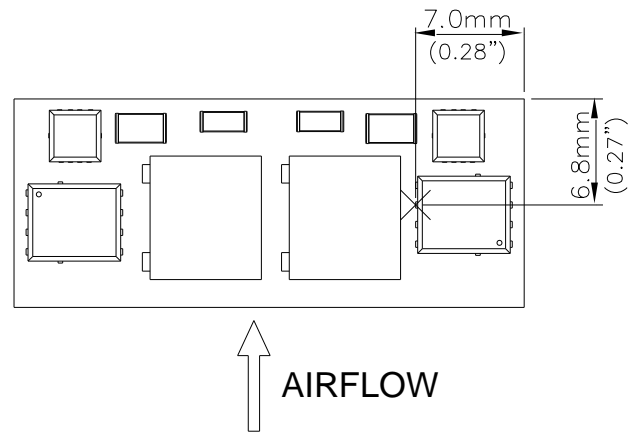

Figure 41: Temperature measurement location

The allowed maximum hot spot temperature is defined at 110°C

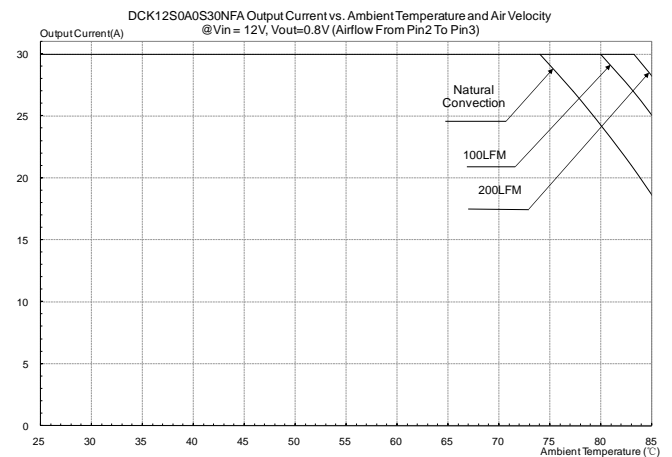

Figure 42: Output current vs. ambient temperature and air velocity @Vin=12V, Vout=0.8V (Airflow direction refer to figure 41)

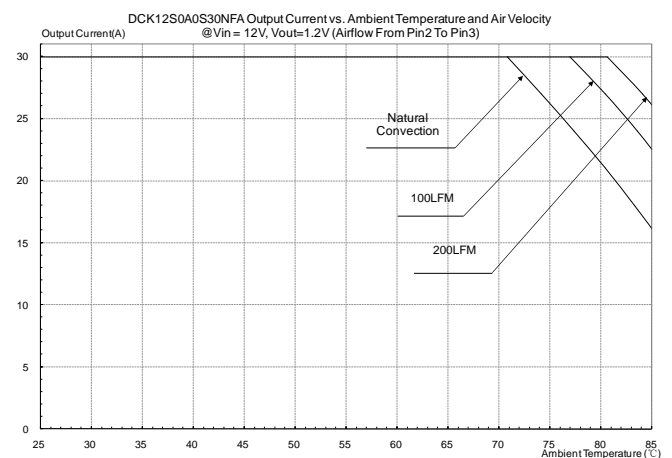

Figure 43: Output current vs. ambient temperature and air velocity @Vin=12V, Vout=1.2V (Airflow direction refer to figure 41)

THERMAL CURVES

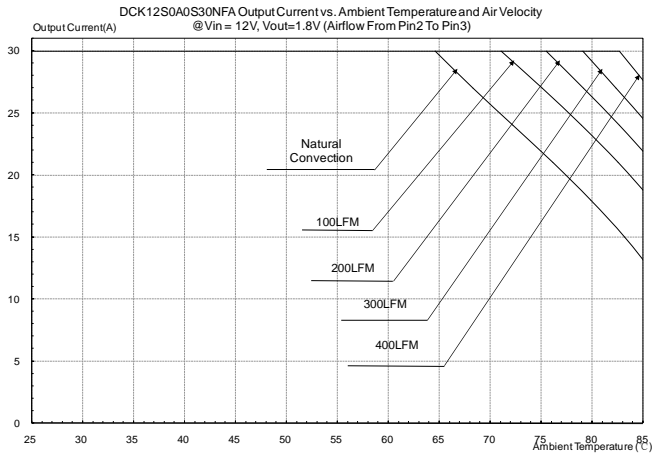

Figure 44: Output current vs. ambient temperature and air velocity @Vin=12V, Vout=1.8V (Airflow direction refer to figure 41)

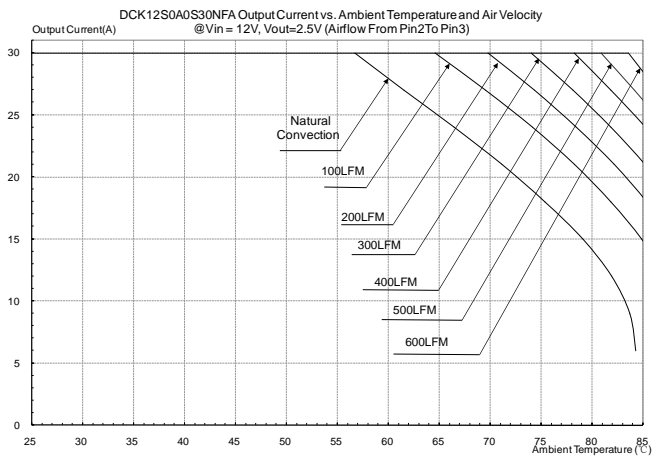

Figure 45: Output current vs. ambient temperature and air velocity @Vin=12V, Vout=2.5V (Airflow direction refer to figure 41)

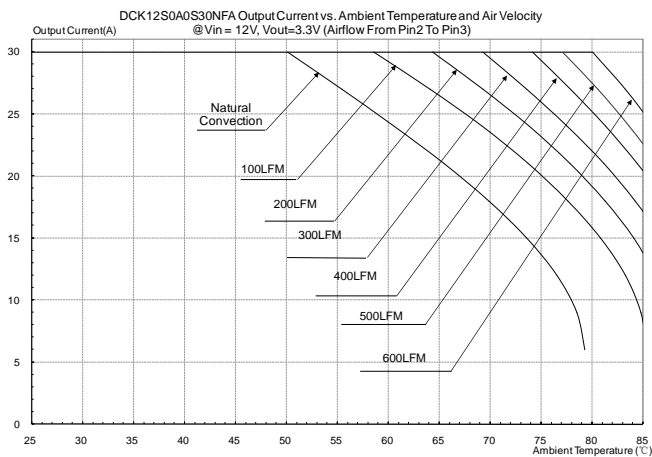
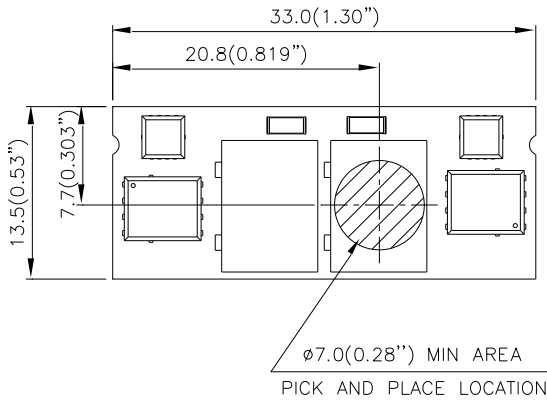

Figure 46: Output current vs. ambient temperature and air velocity @Vin=12V, Vout=3.3V (Airflow direction refer to figure 41)

PICK AND PLACE LOCATION



NOTES:
 ALL DIMENSIONS ARE IN MILLIMETERS AND (INCHES)
 TOLERANCES: X.Xmm±0.5mm(X.XX in.±0.02 in.)
 X.XXmm±0.25mm(X.XXX in.±0.010 in.)

RECOMMENDED PAD LAYOUT

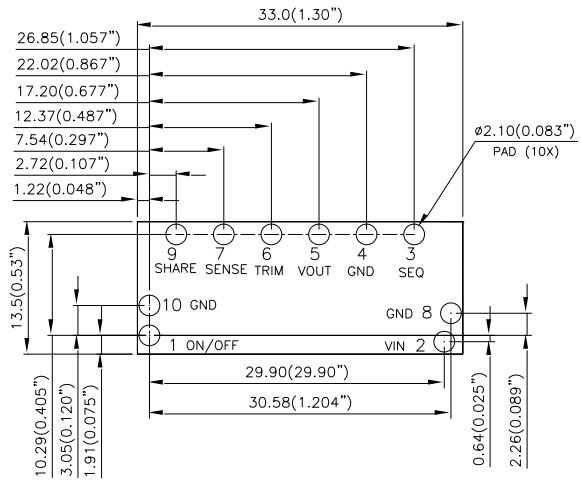

RECOMENDED P.W.B. PAD LAYOUT

NOTES:
 DIMENSIONS ARE IN MILLIMETERS AND (INCHES)
 TOLERANCES: X.Xmm±0.5mm(X.XX in.±0.02 in.)
 X.XXmm±0.25mm(X.XXX in.±0.010 in.)

SURFACE-MOUNT TAPE & REEL

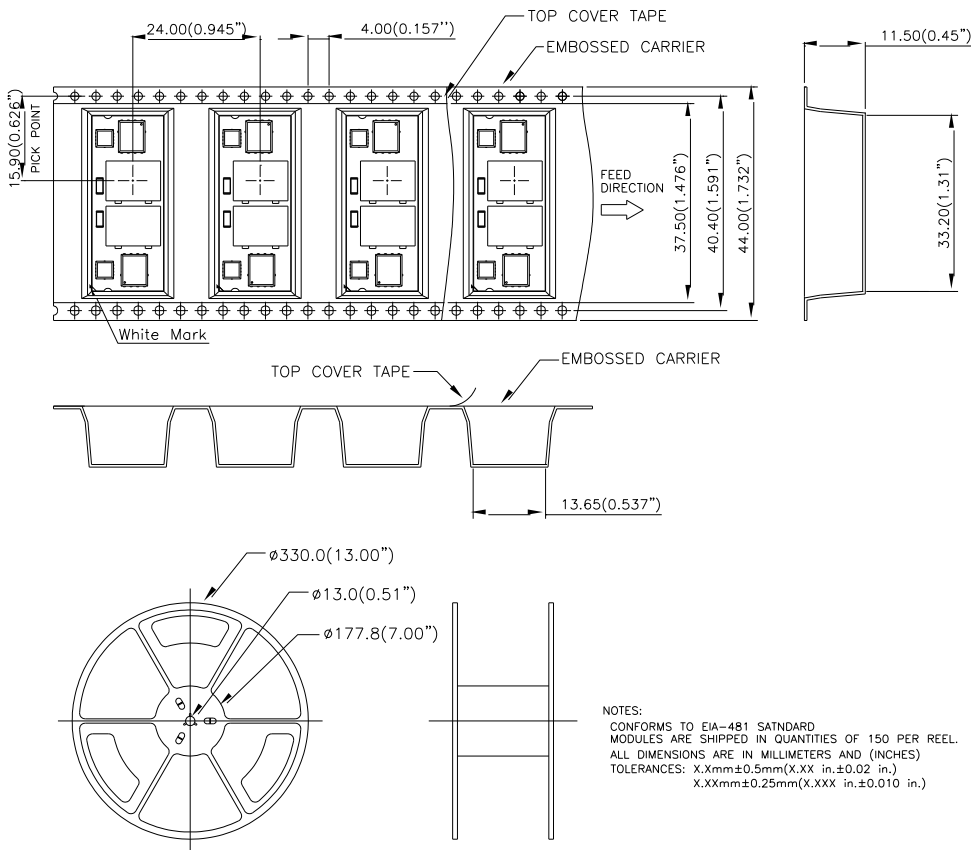

NOTES:
 CONFORMS TO EIA-481 SATNDARD
 MODULES ARE SHIPPED IN QUANTITIES OF 150 PER REEL.
 ALL DIMENSIONS ARE IN MILLIMETERS AND (INCHES)
 TOLERANCES: X.Xmm±0.5mm(X.XX in.±0.02 in.)
 X.XXmm±0.25mm(X.XXX in.±0.010 in.)

LEAD (Sn/Pb) PROCESS RECOMMEND TEMP. PROFILE

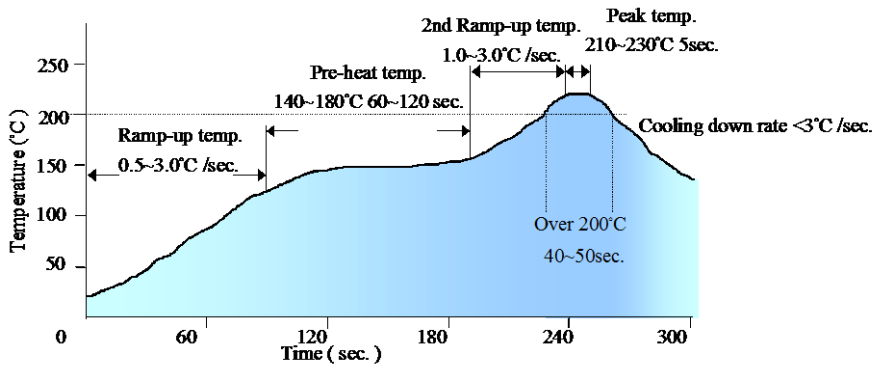

Note: The temperature refers to the pin of DCK, measured on the pin Vout joint.

LEAD FREE (SAC) PROCESS RECOMMEND TEMP. PROFILE

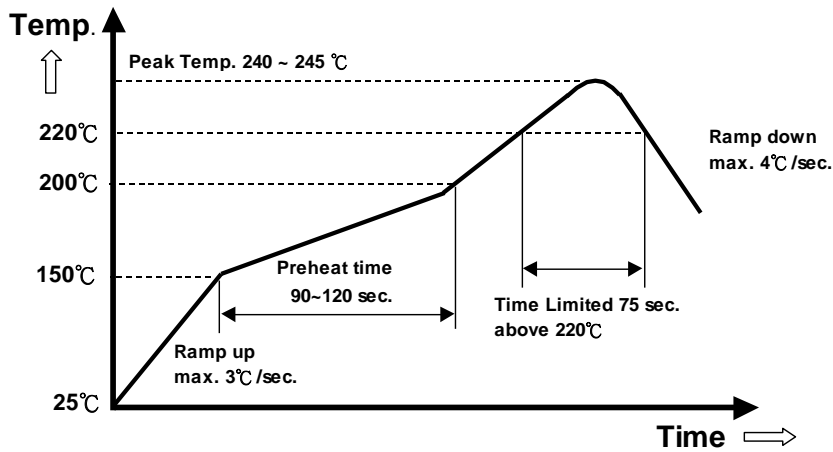

Note: The temperature refers to the pin of DCK, measured on the pin Vout joint.

MECHANICAL DRAWING

All pins are copper alloy with matte-tin(Pb free) plated over Nickel underplating.

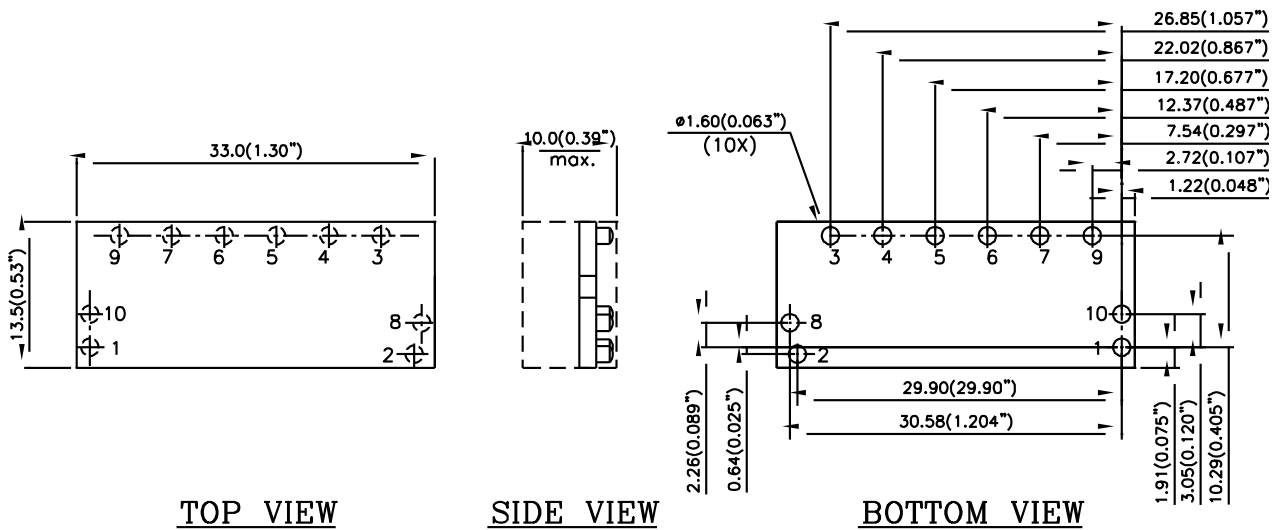

NOTES:
 DIMENSIONS ARE IN MILLIMETERS AND (INCHES)
 TOLERANCES: X.Xmm \pm 0.5mm(X.XX in. \pm 0.02 in.)
 X.XXmm \pm 0.25mm(X.XXX in. \pm 0.010 in.)
 Co-planarity(max):0.13(0.005")

PIN ASSIGNMENT

PIN#	FUNCTION		
1	ON/OFF	6	TRIM
2	VIN	7	SENSE
3	SEQ	8	GND
4	GND	9	SHARE
5	VOUT	10	GND



PART NUMBERING SYSTEM

DCK	12	S	0A0	S	30	N	F	A
Product Series	Input Voltage	Numbers of Outputs	Output Voltage	Package Type	Output Current	On/Off logic		Option Code
DCK – 30A	12 – 6V~14V	S - Single	0A0 - Programmable	S - SMD	30 – 30A	N- negative P- positive	F- RoHS 6/6 (Lead Free)	A = extra ground pin, without current sharing (without pin9) C = extra ground pin, without current sharing (without pin9) D = extra ground pin, with current sharing (with all pins)

MODEL LIST

Model Name	Packaging	Input Voltage	Output Voltage	Output Current	Efficiency 12Vin, 3.3Vdc @ 30A
DCK12S0A0S30NFA	SMD	6V ~ 14Vdc	0.8V~ 3.3Vdc	30A	92.8%

CONTACT: www.deltaww.com/dcdc Email: dcdc@deltaww.com

USA:

Telephone:
East Coast: 978-656-3993
West Coast: 510-668-5100
Fax: (978) 656 3964

Europe:

Telephone: +31-20-655-0967
Fax: +31-20-655-0999

Asia & the rest of world:

Telephone: +886 3 4526107 x6220-6224
Fax: +886 3 4513485

WARRANTY

Delta offers a two (2) year limited warranty. Complete warranty information is listed on our web site or is available upon request from Delta.

Information furnished by Delta is believed to be accurate and reliable. However, no responsibility is assumed by Delta for its use, nor for any infringements of patents or other rights of third parties, which may result from its use. No license is granted by implication or otherwise under any patent or patent rights of Delta. Delta reserves the right to revise these specifications at any time, without notice.

Компания «Life Electronics» занимается поставками электронных компонентов импортного и отечественного производства от производителей и со складов крупных дистрибьюторов Европы, Америки и Азии.

С конца 2013 года компания активно расширяет линейку поставок компонентов по направлению коаксиальный кабель, кварцевые генераторы и конденсаторы (керамические, пленочные, электролитические), за счёт заключения дистрибьюторских договоров

Мы предлагаем:

- Конкурентоспособные цены и скидки постоянным клиентам.
- Специальные условия для постоянных клиентов.
- Подбор аналогов.
- Поставку компонентов в любых объемах, удовлетворяющих вашим потребностям.
- Приемлемые сроки поставки, возможна ускоренная поставка.
- Доставку товара в любую точку России и стран СНГ.
- Комплексную поставку.
- Работу по проектам и поставку образцов.
- Формирование склада под заказчика.
- Сертификаты соответствия на поставляемую продукцию (по желанию клиента).
- Тестирование поставляемой продукции.
- Поставку компонентов, требующих военную и космическую приемку.
- Входной контроль качества.
- Наличие сертификата ISO.

В составе нашей компании организован Конструкторский отдел, призванный помогать разработчикам, и инженерам.

Конструкторский отдел помогает осуществить:

- Регистрацию проекта у производителя компонентов.
- Техническую поддержку проекта.
- Защиту от снятия компонента с производства.
- Оценку стоимости проекта по компонентам.
- Изготовление тестовой платы монтаж и пусконаладочные работы.



Тел: +7 (812) 336 43 04 (многоканальный)
Email: org@lifeelectronics.ru