



Si9130 Demonstration Board

FEATURES

- 5- and 3.3-V Step-Down Synchronous Converters
- Less than 500- μ A Quiescent Current
- 25- μ A Shutdown Current
- 5.5- to 30-V Input Operating Range

DESCRIPTION

The Si9130 Dual-Output Power-Supply Controller for Notebook Computers is a system level integration of two step-down controllers with micropower 5- and 3.3-V linear regulators. The controllers perform high efficiency conversion of the battery pack energy (typically 12 V) or the output of an ac-to-dc wall converter (typically 18 V to 24 V dc) to 5- and 3.3-V system supply voltages. The micropower linear regulator can be used to keep power management and back-up circuitry alive during the shutdown of the step-down converters. The 3.3-V output is adjustable to 3.3 V, 3.45 V or 3.6 V by programming control pins 3.45 ADJ and 3.6 ADJ. Leaving both pins open results in 3.3-V nominal output. Grounding pin 3.45 ADJ while leaving 3.6 ADJ open delivers

3.45-V nominal output. Grounding pin 3.6 ADJ while leaving 3.45 ADJ open delivers 3.6-V nominal output.

On the Demo Board, the Si9130 is configured as a complete system, ready for operation. It takes 5.5- to 30-V in, and produces regulated 5 V at any current from no load to 3 A, and 3.3 V out at any current from no load to 3 A. Included in this document are the Bill of Materials, Demo Board Schematic, and PCB layout.

The demonstration board layout is available in Gerber file format. Please contact your VISHAY sales representative or distributor for a copy.

ORDERING INFORMATION: PART NUMBER Si9130DB

POWER-UP CHECK LIST—INSTALLED IN VRM MOTHER BOARD SOCKET

1. Start by setting the control switches located in the bottom right corner of the Demo Board. Set the top switch to the left, setting the switching frequency to 200 kHz (to the right is 300 kHz). Set the second switch down to the right, turning the 5-V converter on (to the left is off). Set the third switch down to the right, turning the 3.3-V converter on (to the left is off). Set the bottom switch to the right, allowing the PWM to operate (to the left is shutdown).
2. Attach an electronic load set in resistive mode to the 3.3-V output pins. Set the current to 100 mA. Alternatively, you can use a resistor of value 33 Ω , 1 W.
3. Attach an electronic load set in resistive mode to the 5-V output pins. Set the current to 100 mA. Alternatively, you can use a resistor of value 50 Ω , 1 W.
4. Attach a 10-V supply and ground to the pins on the top side of the board. It is best to use a separate wire from the supply's ground to each of the Demo Board's ground pins, because of the high currents at low input voltages.
5. Take an oscilloscope probe, and place the ground on the 5-V GND pin, and the probe on the 5-V pin. Set the vertical scale for this channel at ac coupled at 50 mV/div. Take a second probe, and place the ground on the 5-V GND pin, and the probe on pin 17 (LX₅) of the Si9130. Set this channel at dc coupled 2 V/div. Set the time base at 200 μ sec/div.
6. Leave the probes in place. Change the scale on the second probe (the one attached to pin 17) to 10 V/div, and the time base to 500 nsec/div. Set the 5-V output current on the electronic load to 1 A. Set the input power supply to 16 V. Alternatively, *first turn off the input power supply*, and replace the 50-W resistor with a 5- Ω , 10-W resistor, and then turn the input power supply back on, setting it to 16 V.
7. This step should be performed only if an electronic load is being used. Set the input voltage to 15 V. Remove the second probe (the one attached to pin 17 of the Si9130), or turn off the channel displaying it. Place a current probe around the wire leading from the 5-V output to the electronic load, and set the oscilloscope and amplifier so that it will display approximately 2 A/div. Set the oscilloscope time base back to 200 μ sec/div. Set the 3.3-V electronic load to have a constant 1-A load. Now set up the 5-V electronic load so that it cycles between 100 mA and 3 A at approximately 1 kHz (1 msec period).
8. This step should be performed only if an electronic load is being used. Set the 5-V electronic load back to a constant 1-A current. Remove the voltage probe from the 5-V output. Move the ground of the probe onto the GND pin of the 3.3-V output, and the probe onto the 3.3-V output pin. Remove the current probe from the 5-V output wire, and place it around the wire leading from the 3.3-V output to the electronic load. Now set up the 3.3-V electronic load so that it cycles between 100 mA and 3 A at approximately 1 kHz (1 msec period).

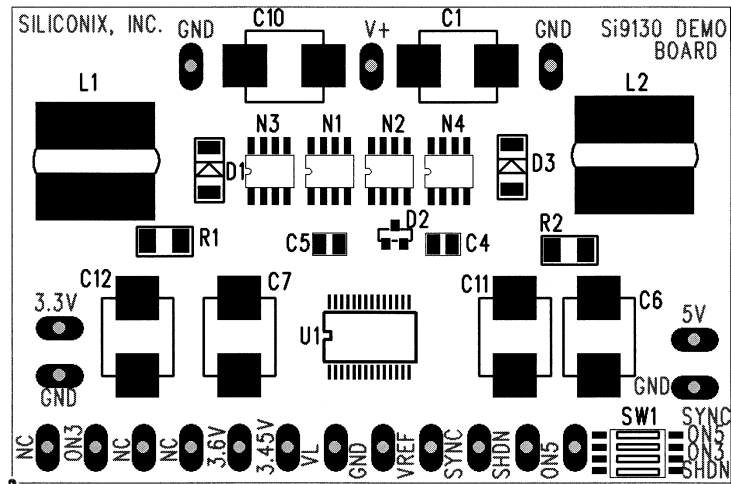

FIGURE 1. Top Silkscreen

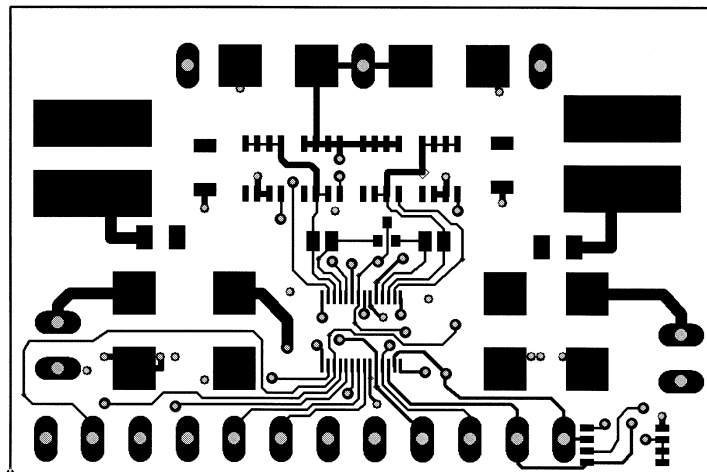

FIGURE 2. Top Layer

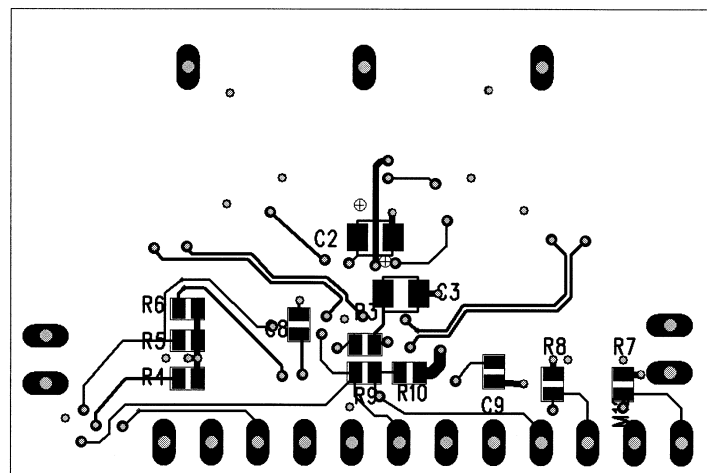
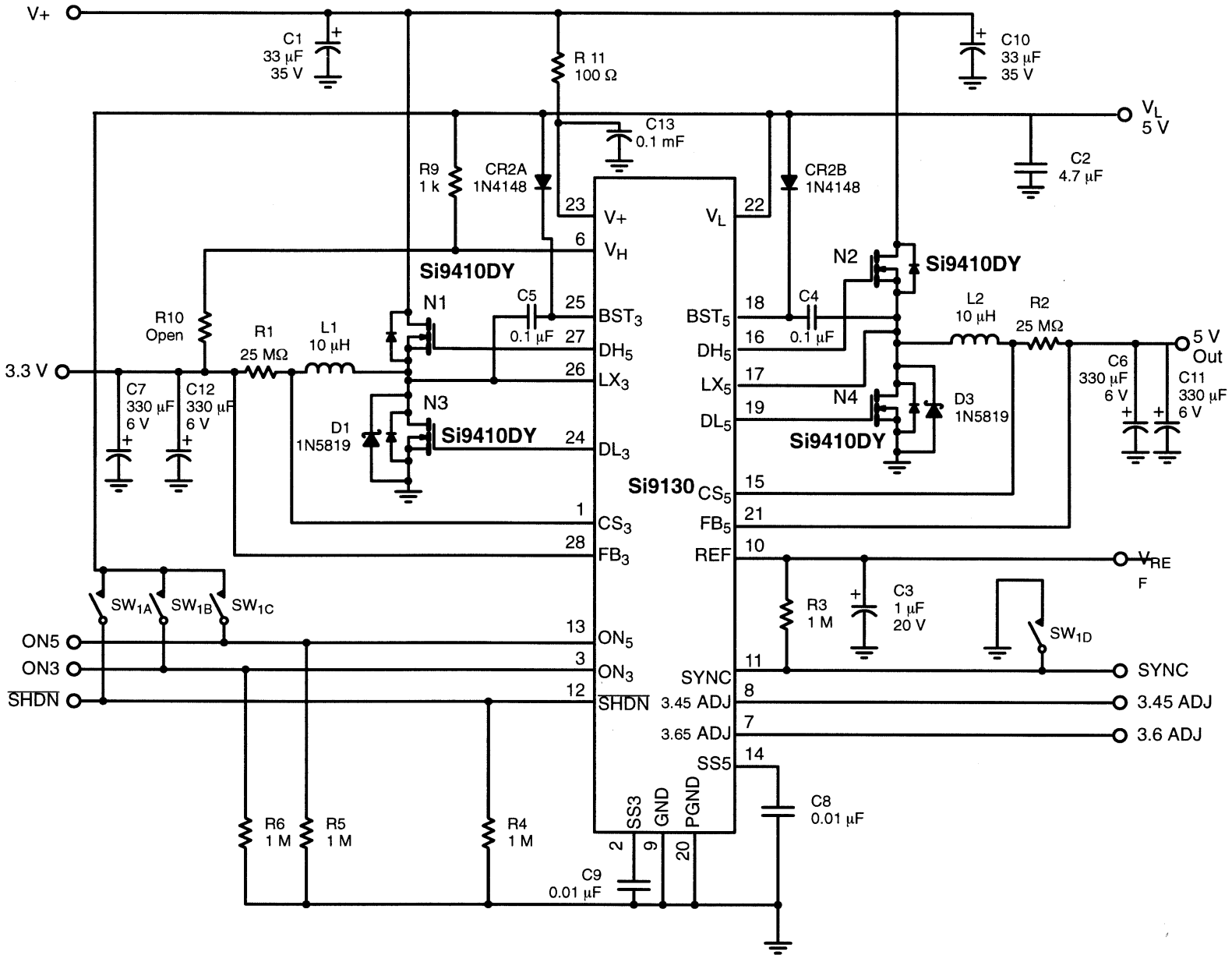

FIGURE 3. Bottom Layer



Si9130DB APPLICATION CIRCUIT





BILL OF MATERIAL FOR Si9130 DUAL-OUTPUT POWER SUPPLY						
Part	Used	Reference Designators	Part Type	Description/Part Number	Pattern	Manufacturer
1	1	U1	Si9130	D-O PWR Supply, Si9130	SSOP-28	Vishay Siliconix
2	2	L1, L2	10 μ H	Inductor, 10 μ H, CRD125-100	CDR125-100	Sumida
3	4	N1-N4	Si9410DY	N-Channel MOSFET, Si9410DY	SO-8	Vishay Siliconix
4	1	SW1	SPST	SW-SPST	DIP-4	Multi-Source
5	2	D1, D3	1N5819	Diode, 1N5819	SOD-87	Nikon
6	1	CR2	CMPD2836	Diode, CMPD2836	SOT-23	Central Semiconductor
7	2	R1, R2	0.025 Ω , 1%	Resistor, LR2010-01-R025F	2010	IRC
8	6	R3-R6	1 M Ω	Resistor, CRCW0805105JRT1	0805	Vishay Dale
9	1	R9	1 k Ω	Resistor, CRCW0805102JRT1	0805	Vishay Dale
10	1	R10	Open	Resistor, (Open)	0805	Multi-Source
11	1	R11	100 Ω	Resistor, CRCW0805101JRT1	0805	Vishay Dale
12	2	C1, C10	33 μ F, 35 V	Capacitor, Tantalum, 595D336X0035SR	R	Vishay Sprague
13	1	C2	4.7 μ F, 6 V	Capacitor, Ceramic, 1206YG475ZAT	1206	AVX
14	2	C3	1 μ F, 20 V	Capacitor, Tantalum, TAJA105M025	A	AVX
15	2	C4, C5	0.1 μ F, 16 V	Capacitor, VJ0805Y104KXXAT	0805	Vishay Vitramon
16	1	C6, C7, C11, C12	330 μ F, 6 V	Capacitor, Tantalum, TPSE337M006R0100	E	AVX
17	2	C8, C9	0.01 μ F, 16 V	Capacitor, VJ0805Y103KXXAT	0805	Vishay Vitramon
18	1	C13	0.1 μ F, 35 V	Capacitor, VJ0805Y104KXAAT	0805	Vishay Vitramon

Компания «Life Electronics» занимается поставками электронных компонентов импортного и отечественного производства от производителей и со складов крупных дистрибьюторов Европы, Америки и Азии.

С конца 2013 года компания активно расширяет линейку поставок компонентов по направлению коаксиальный кабель, кварцевые генераторы и конденсаторы (керамические, пленочные, электролитические), за счёт заключения дистрибьюторских договоров

Мы предлагаем:

- Конкурентоспособные цены и скидки постоянным клиентам.
- Специальные условия для постоянных клиентов.
- Подбор аналогов.
- Поставку компонентов в любых объемах, удовлетворяющих вашим потребностям.
- Приемлемые сроки поставки, возможна ускоренная поставка.
- Доставку товара в любую точку России и стран СНГ.
- Комплексную поставку.
- Работу по проектам и поставку образцов.
- Формирование склада под заказчика.
- Сертификаты соответствия на поставляемую продукцию (по желанию клиента).
- Тестирование поставляемой продукции.
- Поставку компонентов, требующих военную и космическую приемку.
- Входной контроль качества.
- Наличие сертификата ISO.

В составе нашей компании организован Конструкторский отдел, призванный помогать разработчикам, и инженерам.

Конструкторский отдел помогает осуществить:

- Регистрацию проекта у производителя компонентов.
- Техническую поддержку проекта.
- Защиту от снятия компонента с производства.
- Оценку стоимости проекта по компонентам.
- Изготовление тестовой платы монтаж и пусконаладочные работы.



Тел: +7 (812) 336 43 04 (многоканальный)
Email: org@lifeelectronics.ru