

Single-Chip Ethernet Controller with HP Auto-MDIX Support and PCI Interface

PRODUCT FEATURES

Datasheet

Highlights

- Optimized for embedded applications with 32-bit RISC CPUs
- Integrated descriptor based scatter-gather DMA and IRQ deassertion timer effectively increase network throughput and reduce CPU loading
- Integrated Ethernet MAC with full-duplex support
- Integrated 10/100 Ethernet PHY with HP Auto-MDIX support
- 32-bit, 33MHz, PCI 3.0 compliant interface
- Reduced power operating modes with PCI Power Management Specification 1.1 compliance
- Supports multiple audio & video streams over Ethernet

Target Applications

- Cable, satellite, and IP set-top boxes
- Digital televisions
- Digital video recorders
- Home gateways
- Digital media clients/servers
- Industrial automation systems
- Industrial/single board PC
- Kiosk/POS enterprise equipment

Key Benefits

- Integrated High-Performance 10/100 Ethernet Controller
 - Fully compliant with IEEE802.3/802.3u
 - Integrated Ethernet MAC and PHY
 - 10BASE-T and 100BASE-TX support
 - Full- and half-duplex support
 - Full-duplex flow control
 - Preamble generation and removal
 - Automatic 32-bit CRC generation and checking
 - Automatic payload padding and pad removal
 - Loop-back modes
 - Flexible address filtering modes
 - One 48-bit perfect address
 - 64 hash-filtered multicast addresses
 - Pass all multicast

- Promiscuous mode
- Inverse filtering
- Pass all incoming with status report
- Wakeup packet support
- Integrated 10/100 Ethernet PHY
 - Auto-negotiation
 - Automatic polarity detection and correction
 - Supports HP Auto-MDIX
 - Supports energy-detect power down
- Support for 3 status LEDs
- Receive and transmit TCP checksum offload
- PCI Interface
 - PCI Local Bus Specification Revision 3.0 compliant
 - 32-bit/33-MHz PCI bus
 - Descriptor based scatter-gather DMA enables zero-copy drivers
- Comprehensive Power Management Features
 - Supports PCI Bus Power Management Interface Specification, Revision 1.1
 - Supports optional wake from D3cold (via configuration strap option when Vaux is available)
 - Wake on LAN
 - Wake on link status change (energy detect)
 - Magic packet wakeup
- General Purpose I/O
 - 3 programmable GPIO pins
 - 2 GPO pins
- Support for Optional EEPROM
 - Serial interface provided for EEPROM
 - Used to store PCI and MAC address configuration values
- Miscellaneous Features
 - Big/Little/Mixed endian support for registers, descriptors, and buffers
 - IRQ deassertion timer
 - General purpose timer
- Single 3.3V Power Supply
 - Integrated 1.8V regulator
- Packaging
 - Available in 128-pin VTQFP Lead-free RoHS Compliant package
- Environmental
 - Available in commercial & industrial temperature ranges

Order Numbers:**LAN9420-NU For 128-PIN VTQFP, Lead-Free RoHS Compliant Package (0 to 70°C)****LAN9420i-NU For 128-PIN VTQFP, Lead-Free RoHS Compliant Package (-40° to 85°C)****This product meets the halogen maximum concentration values per IEC61249-2-21****For RoHS compliance and environmental information, please visit www.smSC.com/rohs**

80 ARKAY DRIVE, HAUPPAUGE, NY 11788 (631) 435-6000 or 1 (800) 443-SEMI

Copyright © 2011 SMSC or its subsidiaries. All rights reserved.

Circuit diagrams and other information relating to SMSC products are included as a means of illustrating typical applications. Consequently, complete information sufficient for construction purposes is not necessarily given. Although the information has been checked and is believed to be accurate, no responsibility is assumed for inaccuracies. SMSC reserves the right to make changes to specifications and product descriptions at any time without notice. Contact your local SMSC sales office to obtain the latest specifications before placing your product order. The provision of this information does not convey to the purchaser of the described semiconductor devices any licenses under any patent rights or other intellectual property rights of SMSC or others. All sales are expressly conditional on your agreement to the terms and conditions of the most recently dated version of SMSC's standard Terms of Sale Agreement dated before the date of your order (the "Terms of Sale Agreement"). The product may contain design defects or errors known as anomalies which may cause the product's functions to deviate from published specifications. Anomaly sheets are available upon request. SMSC products are not designed, intended, authorized or warranted for use in any life support or other application where product failure could cause or contribute to personal injury or severe property damage. Any and all such uses without prior written approval of an Officer of SMSC and further testing and/or modification will be fully at the risk of the customer. Copies of this document or other SMSC literature, as well as the Terms of Sale Agreement, may be obtained by visiting SMSC's website at <http://www.smSC.com>. SMSC is a registered trademark of Standard Microsystems Corporation ("SMSC"). Product names and company names are the trademarks of their respective holders.

SMSC DISCLAIMS AND EXCLUDES ANY AND ALL WARRANTIES, INCLUDING WITHOUT LIMITATION ANY AND ALL IMPLIED WARRANTIES OF MERCHANTABILITY, FITNESS FOR A PARTICULAR PURPOSE, TITLE, AND AGAINST INFRINGEMENT AND THE LIKE, AND ANY AND ALL WARRANTIES ARISING FROM ANY COURSE OF DEALING OR USAGE OF TRADE. IN NO EVENT SHALL SMSC BE LIABLE FOR ANY DIRECT, INCIDENTAL, INDIRECT, SPECIAL, PUNITIVE, OR CONSEQUENTIAL DAMAGES; OR FOR LOST DATA, PROFITS, SAVINGS OR REVENUES OF ANY KIND; REGARDLESS OF THE FORM OF ACTION, WHETHER BASED ON CONTRACT; TORT; NEGLIGENCE OF SMSC OR OTHERS; STRICT LIABILITY; BREACH OF WARRANTY; OR OTHERWISE; WHETHER OR NOT ANY REMEDY OF BUYER IS HELD TO HAVE FAILED OF ITS ESSENTIAL PURPOSE, AND WHETHER OR NOT SMSC HAS BEEN ADVISED OF THE POSSIBILITY OF SUCH DAMAGES.

Table of Contents

Chapter 1	Introduction	11
1.1	Block Diagrams	11
1.2	General Description	12
1.3	PCI Bridge	13
1.4	DMA Controller	13
1.5	Ethernet MAC	13
1.6	Ethernet PHY	13
1.7	System Control Block	13
1.7.1	Interrupt Controller	13
1.7.2	PLL and Power Management	14
1.7.3	EEPROM Controller	14
1.7.4	GPIO/LED Controller	14
1.7.5	General Purpose Timer	14
1.7.6	Free Run Counter	14
1.8	Control and Status Registers (CSR)	14
Chapter 2	Pin Description and Configuration	15
2.1	Pin List	16
2.2	Buffer Types	22
Chapter 3	Functional Description	23
3.1	Functional Overview	23
3.2	PCI Bridge (PCIB)	23
3.2.1	PCI Bridge (PCIB) Block Diagram	24
3.2.2	PCI Interface Environments	25
3.2.3	PCI Master Interface	25
3.2.3.1	PCI Master Transaction Errors	25
3.2.4	PCI Target Interface	26
3.2.4.1	PCI Configuration Space Registers	26
3.2.4.2	Control and Status Registers (CSR)	26
3.2.4.2.1	CSR Endianness	26
3.2.4.2.2	I/O Mapping of CSR	27
3.2.4.3	PCI Target Interface Transaction Errors	27
3.2.4.4	PCI Discard Timer	27
3.2.5	Interrupt Gating Logic	27
3.3	System Control Block (SCB)	28
3.3.1	Interrupt Controller	28
3.3.2	Wake Event Detection Logic	30
3.3.3	General Purpose Timer (GPT)	30
3.3.4	Free-Run Counter (FRC)	31
3.3.5	EEPROM Controller (EPC)	31
3.3.5.1	EEPROM Format	31
3.3.5.2	MAC Address, Subsystem ID, and Subsystem Vendor ID Auto-Load	32
3.3.5.3	EEPROM Host Operations	32
3.3.5.3.1	Supported EEPROM Operations	34
3.3.5.3.2	Host Initiated MAC Address, SSID, SSVID Reload	37
3.3.5.3.3	EEPROM Command and Data Registers	37
3.3.5.3.4	EEPROM Timing	37
3.3.6	System Control and Status Registers (SCSR)	38
3.4	DMA Controller (DMAC)	38
3.4.1	DMA Controller Architecture	38

3.4.2	Data Descriptors and Buffers	39
3.4.2.1	Receive Descriptors	41
3.4.2.2	Transmit descriptors	45
3.4.3	Initialization	50
3.4.4	Transmit Operation	50
3.4.5	Receive Operation	50
3.4.6	Receive Descriptor Acquisition	51
3.4.7	Suspend State Behavior	51
3.4.7.1	Transmit Engine	51
3.4.7.2	Receive Engine	51
3.4.8	Stopping Transmission and Reception	52
3.4.9	TX Buffer Fragmentation Rules	52
3.4.9.1	Calculating Worst-Case TX FIFO (MIL) Usage	52
3.4.10	DMAC Interrupts	52
3.4.11	DMAC Control and Status Registers (DCSR)	53
3.5	10/100 Ethernet MAC	53
3.5.1	Flow Control	54
3.5.1.1	Full-Duplex Flow Control	54
3.5.2	Virtual Local Area Network (VLAN) Support	55
3.5.3	Address Filtering Functional Description	56
3.5.3.1	Perfect Filtering	56
3.5.3.2	Hash Only Filtering Mode	56
3.5.3.3	Hash Perfect Filtering	57
3.5.3.4	Inverse Filtering	57
3.5.4	Wakeup Frame Detection	57
3.5.4.1	Magic Packet Detection	60
3.5.5	Receive Checksum Offload Engine (RXCOE)	60
3.5.5.1	RX Checksum Calculation	63
3.5.6	Transmit Checksum Offload Engine (TXCOE)	63
3.5.6.1	TX Checksum Calculation	64
3.5.7	MAC Control and Status Registers (MCSR)	64
3.6	10/100 Ethernet PHY	64
3.6.1	100BASE-TX Transmit	65
3.6.1.1	4B/5B Encoding	65
3.6.1.2	Scrambling	67
3.6.1.3	NRZI and MLT3 Encoding	67
3.6.1.4	100M Transmit Driver	67
3.6.1.5	100M Phase Lock Loop (PLL)	67
3.6.2	100BASE-TX Receive	68
3.6.2.1	100M Receive Input	68
3.6.2.2	Equalizer, Baseline Wander Correction and Clock and Data Recovery	68
3.6.2.3	NRZI and MLT-3 Decoding	68
3.6.2.4	Descrambling	69
3.6.2.5	Alignment	69
3.6.2.6	5B/4B Decoding	69
3.6.2.7	Receiver Errors	69
3.6.3	10BASE-T Transmit	69
3.6.3.1	10M Transmit Data Across the Internal MII Bus	70
3.6.3.2	Manchester Encoding	70
3.6.3.3	10M Transmit Drivers	70
3.6.4	10BASE-T Receive	70
3.6.4.1	10M Receive Input and Squelch	70
3.6.4.2	Manchester Decoding	70
3.6.4.3	Jabber Detection	70

Datasheet

3.6.5	Auto-negotiation	71
3.6.6	Parallel Detection	72
3.6.6.1	Re-starting Auto-negotiation	72
3.6.6.2	Disabling Auto-negotiation	72
3.6.6.3	Half vs. Full-Duplex	72
3.6.7	HP Auto-MDIX	73
3.6.8	PHY Power-Down Modes	73
3.6.8.1	General Power-Down	73
3.6.8.2	Energy Detect Power-Down	74
3.6.9	PHY Resets	74
3.6.9.1	PHY Soft Reset via PMT_CTRL bit 10 (PHY_RST)	74
3.6.9.2	PHY Soft Reset via PHY Basic Control Register bit 15 (PHY Reg. 0.15)	74
3.6.10	Required Ethernet Magnetics	74
3.6.11	PHY Registers	74
3.7	Power Management	74
3.7.1	Overview	74
3.7.2	Related External Signals and Power Supplies	75
3.7.3	Device Clocking	75
3.7.4	Power States	76
3.7.4.1	G3 State (Mechanical Off)	76
3.7.4.1.1	Power Management Events in G3	76
3.7.4.1.2	Exiting the G3 State	76
3.7.4.2	D0UNINITIALIZED State (D0U)	77
3.7.4.2.1	Exiting the D0U State	77
3.7.4.3	D0ACTIVE State (D0A)	77
3.7.4.3.1	Power Management Events in D0A	77
3.7.4.3.2	Exiting the D0A State	78
3.7.4.4	The D3HOT State	78
3.7.4.4.1	Power Management Events in D3HOT	78
3.7.4.4.2	Exiting the D3HOT State	78
3.7.4.5	The D3COLD State	79
3.7.4.5.1	Power Management Events in D3COLD	79
3.7.4.5.2	Exiting the D3COLD State	79
3.7.5	Resets	79
3.7.5.1	PHY Resets	80
3.7.6	Detecting Power Management Events	81
3.7.6.1	Enabling Wakeup Frame Wake Events	82
3.7.7	Enabling Link Status Change (Energy Detect) Wake Events	82
<hr/>		
Chapter 4	Register Descriptions	84
4.1	Register Nomenclature	86
4.2	System Control and Status Registers (SCSR)	87
4.2.1	ID and Revision (ID_REV)	88
4.2.2	Interrupt Control Register (INT_CTL)	89
4.2.3	Interrupt Status Register (INT_STS)	90
4.2.4	Interrupt Configuration Register (INT_CFG)	92
4.2.5	General Purpose Input/Output Configuration Register (GPIO_CFG)	93
4.2.6	General Purpose Timer Configuration Register (GPT_CFG)	95
4.2.7	General Purpose Timer Current Count Register (GPT_CNT)	96
4.2.8	Bus Master Bridge Configuration Register (BUS_CFG)	97
4.2.9	Power Management Control Register (PMT_CTRL)	98
4.2.10	Free Run Counter (FREE_RUN)	99
4.2.11	EEPROM Command Register (E2P_CMD)	100
4.2.12	EEPROM Data Register (E2P_DATA)	103

4.3	DMAC Control and Status Registers (DCSR)	104
4.3.1	Bus Mode Register (BUS_MODE)	105
4.3.2	Transmit Poll Demand Register (TX_POLL_DEMAND)	106
4.3.3	Receive Poll Demand Register (RX_POLL_DEMAND)	107
4.3.4	Receive List Base Address Register (RX_BASE_ADDR)	108
4.3.5	Transmit List Base Address Register (TX_BASE_ADDR)	109
4.3.6	DMA Controller Status Register (DMAC_STATUS)	110
4.3.7	DMA Controller Control (Operation Mode) Register (DMAC_CONTROL)	112
4.3.8	DMA Controller Interrupt Enable Register (DMAC_INTR_ENA)	114
4.3.9	Missed Frame and Buffer Overflow Counter Reg (MISS_FRAME_CNTR)	116
4.3.10	Current Transmit Buffer Address Register (TX_BUFF_ADDR)	117
4.3.11	Current Receive Buffer Address Register (RX_BUFF_ADDR)	118
4.4	MAC Control and Status Registers (MCSR)	119
4.4.1	MAC Control Register (MAC_CR)	120
4.4.2	MAC Address High Register (ADDRH)	124
4.4.3	MAC Address Low Register (ADDRL)	125
4.4.4	Multicast Hash Table High Register (HASHH)	126
4.4.5	Multicast Hash Table Low Register (HASHL)	127
4.4.6	MII Access Register (MII_ACCESS)	128
4.4.7	MII Data Register (MII_DATA)	129
4.4.8	Flow Control Register (FLOW)	130
4.4.9	VLAN1 Tag Register (VLAN1)	131
4.4.10	VLAN2 Tag Register (VLAN2)	132
4.4.11	Wakeup Frame Filter (WUFF)	133
4.4.12	Wakeup Control and Status Register (WUCSR)	134
4.4.13	Checksum Offload Engine Control Register (COE_CR)	135
4.5	PHY Registers	136
4.5.1	Basic Control Register	137
4.5.2	Basic Status Register	138
4.5.3	PHY Identifier 1	139
4.5.4	PHY Identifier 2	140
4.5.5	Auto Negotiation Advertisement	141
4.5.6	Auto Negotiation Link Partner Ability	142
4.5.7	Auto Negotiation Expansion	143
4.5.8	Mode Control/Status	144
4.5.9	Special Modes	145
4.5.10	Special Control/Status Indications	146
4.5.11	Interrupt Source Flag	147
4.5.12	Interrupt Mask	148
4.5.13	PHY Special Control/Status	149
4.6	PCI Configuration Space CSR (CONFIG_CSR)	150
4.6.1	PCI Power Management Capabilities Register (PCI_PMC)	152
4.6.2	PCI Power Management Control and Status Register (PCI_PMCSR)	154

Chapter 5 Operational Characteristics 156

5.1	Absolute Maximum Ratings*	156
5.2	Operating Conditions**	156
5.3	Power Consumption	157
5.3.1	D0 - Normal Operation with Ethernet Traffic	157
5.3.2	D3 - Enabled for Wake Up Packet Detection	158
5.3.3	D3 - Enabled for Link Status Change Detection (Energy Detect)	158
5.3.4	D3 - PHY in General Power Down Mode	159
5.3.5	Maximum Power Consumption	159
5.4	DC Specifications	160



Datasheet

5.5	AC Specifications	162
5.5.1	Equivalent Test Load (Non-PCI Signals)	162
5.6	PCI Clock Timing	163
5.7	PCI I/O Timing	164
5.8	EEPROM Timing	166
5.9	Clock Circuit	167
<hr/>		
Chapter 6	Package Outline	168
6.1	128-VTQFP Package	168
<hr/>		
Chapter 7	Datasheet Revision History	170

List of Figures

Figure 1.1	System Level Block Diagram	11
Figure 1.2	LAN9420/LAN9420i Internal Block Diagram	11
Figure 2.1	LAN9420/LAN9420i 128-VTQFP (Top View)	15
Figure 3.1	PCI Bridge Block Diagram	24
Figure 3.2	Device Operation	25
Figure 3.3	CSR Double Endian Mapping	27
Figure 3.4	I/O Bar Mapping	27
Figure 3.5	Interrupt Generation	28
Figure 3.6	Interrupt Controller Block Diagram	29
Figure 3.7	EEPROM Access Flow Diagram	33
Figure 3.8	EEPROM ERASE Cycle	34
Figure 3.9	EEPROM ERAL Cycle	34
Figure 3.10	EEPROM EWDS Cycle	35
Figure 3.11	EEPROM EWEN Cycle	35
Figure 3.12	EEPROM READ Cycle	36
Figure 3.13	EEPROM WRITE Cycle	36
Figure 3.14	EEPROM WRAL Cycle	37
Figure 3.15	Ring and Chain Descriptor Structures	40
Figure 3.16	Receive Descriptor	41
Figure 3.17	Transmit Descriptor	45
Figure 3.18	VLAN Frame	55
Figure 3.19	RXCoe Checksum Calculation	61
Figure 3.20	Type II Ethernet Frame	61
Figure 3.21	Ethernet Frame with VLAN Tag	61
Figure 3.22	Ethernet Frame with Length Field and SNAP Header	62
Figure 3.23	Ethernet Frame with VLAN Tag and SNAP Header	62
Figure 3.24	Ethernet Frame with multiple VLAN Tags and SNAP Header	62
Figure 3.25	100BASE-TX Data Path	65
Figure 3.26	Receive Data Path	68
Figure 3.27	Direct Cable Connection vs. Cross-Over Cable Connection	73
Figure 3.28	LAN9420/LAN9420i Device Power States	76
Figure 3.29	Wake Event Detection Block Diagram	81
Figure 4.1	LAN9420/LAN9420i CSR Memory Map	85
Figure 4.2	Example ADDR_L, ADDR_H Address Ordering	125
Figure 5.1	Output Equivalent Test Load	162
Figure 5.2	PCI Clock Timing	163
Figure 5.3	PCI I/O Timing	164
Figure 5.4	EEPROM Timing	166
Figure 6.1	LAN9420/LAN9420i 128-VTQFP Package Definition	168
Figure 6.2	LAN9420/LAN9420i 128-VTQFP Recommended PCB Land Pattern	169

List of Tables

Table 2.1	PCI Bus Interface Pins	16
Table 2.2	EEPROM	17
Table 2.3	GPIO and LED Pins	18
Table 2.4	Configuration Pins	18
Table 2.5	PLL and Ethernet PHY Pins	19
Table 2.6	Power and Ground Pins	20
Table 2.7	No-Connect Pins	20
Table 2.8	128-VTQFP Package Pin Assignments	21
Table 3.1	PCI Address Spaces	26
Table 3.2	EEPROM Format	31
Table 3.3	EEPROM Variable Defaults	32
Table 3.4	Required EECLK Cycles	37
Table 3.5	RDES0 Bit Fields	41
Table 3.6	RDES1 Bit Fields	44
Table 3.7	RDES2 Bit Fields	44
Table 3.8	RDES3 Bit Fields	45
Table 3.9	TDES0 Bit Fields	46
Table 3.10	TDES1 Bit Fields	47
Table 3.11	TDES2 Bit Fields	49
Table 3.12	TDES3 Bit Fields	49
Table 3.13	Address Filtering Modes	56
Table 3.14	WakeUp Frame Filter Register Structure	58
Table 3.15	Filter i Byte Mask Bit Definitions	58
Table 3.16	Filter i Command Bit Definitions	58
Table 3.17	Filter i Offset Bit Definitions	59
Table 3.18	Filter i CRC-16 Bit Definitions	59
Table 3.19	WakeUp Generation Cases	59
Table 3.20	TX Checksum Preamble	64
Table 3.21	4B/5B Code Table	66
Table 3.22	Reset Map	80
Table 3.23	PHY Resets	81
Table 4.1	Register Bit Types	86
Table 4.2	System Control and Status Register Addresses	87
Table 4.3	EEPROM Enable Bit Definitions	94
Table 4.4	DMAC Control and Status Register (DCSR) Map	104
Table 4.5	MAC Control and Status Register (MCSR) Map	119
Table 4.6	ADDRL, ADDRH Byte Ordering	125
Table 4.7	PHY Control and Status Registers	136
Table 4.8	MODE Control	145
Table 4.9	PCI Configuration Space CSR (CONFIG CSR) Address Map	150
Table 4.10	Standard PCI Header Registers Supported	151
Table 5.1	D0 - Normal Operation - Supply and Current (Typical)	157
Table 5.2	D3 - Enabled for Wake Up Packet Detection - Supply and Current (Typical)	158
Table 5.3	D3 - Enabled for Link Status Change Detection - Supply and Current (Typical)	158
Table 5.4	D3 - PHY in General Power Down Mode - Supply and Current (Typical)	159
Table 5.5	Maximum Power Consumption - Supply and Current (Maximum)	159
Table 5.6	I/O Buffer Characteristics	160
Table 5.7	100BASE-TX Transceiver Characteristics	161
Table 5.8	10BASE-T Transceiver Characteristics	161
Table 5.9	PCI Clock Timing Values	163
Table 5.10	PCI I/O Timing Measurement Conditions	164
Table 5.11	PCI I/O Timing Values	165



Table 5.12 EEPROM Timing Values	166
Table 5.13 LAN9420/LAN9420i Crystal Specifications	167
Table 6.1 LAN9420/LAN9420i 128-VTQFP Dimensions	169
Table 7.1 Customer Revision History	170

Chapter 1 Introduction

1.1 Block Diagrams

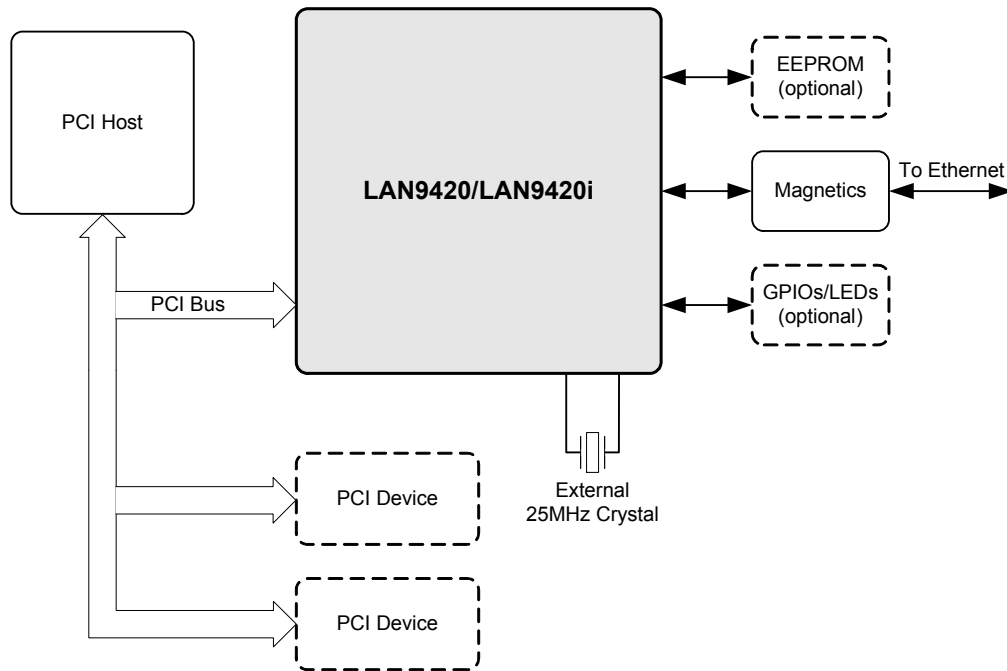

Figure 1.1 System Level Block Diagram

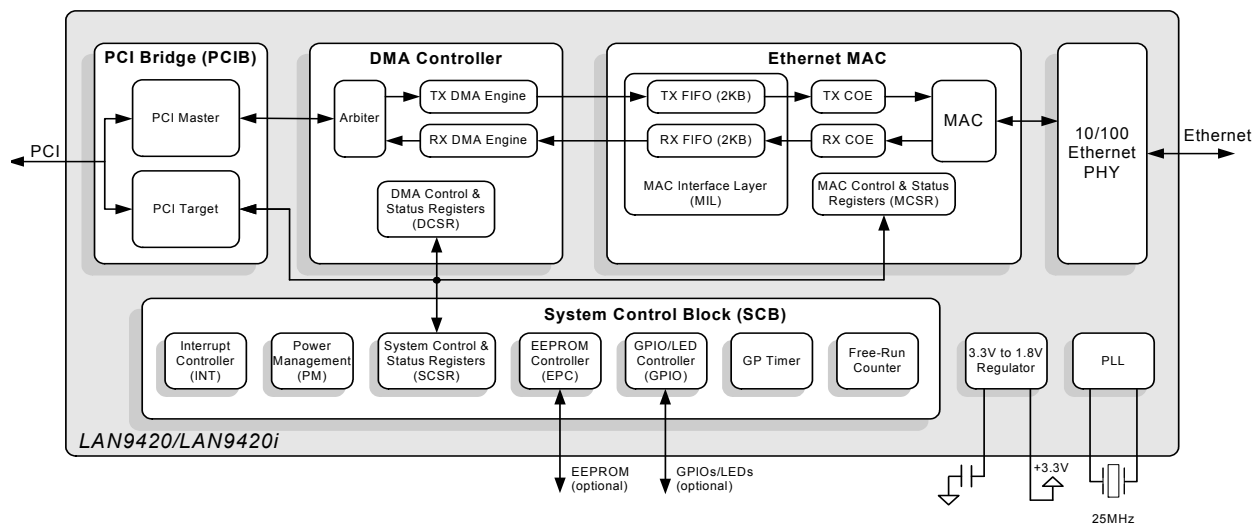

Figure 1.2 LAN9420/LAN9420i Internal Block Diagram

1.2 General Description

LAN9420/LAN9420i is a full-featured, Fast Ethernet controller which allows for the easy and cost-effective integration of Fast Ethernet into a PCI-based system. A system configuration diagram of LAN9420/LAN9420i in a typical embedded environment can be seen in [Figure 1.1](#), followed by an internal block diagram of LAN9420/LAN9420i in [Figure 1.2](#). LAN9420/LAN9420i consists of a PCI Local Bus Specification Revision 3.0 compliant interface, DMA Controller, Ethernet MAC, and 10/100 Ethernet PHY.

LAN9420/LAN9420i provides full IEEE 802.3 compliance and all internal components support full/half-duplex 10BASE-T, 100BASE-TX, and manual full-duplex flow control. The descriptor based scatter-gather DMA supports usage of zero-copy drivers, effectively increasing throughput while decreasing Host load. The integrated IRQ deassertion timer allows a minimum IRQ deassertion time to be set, providing reduced Host load and greater control over service routines. Automatic 32-bit CRC generation/checking, automatic payload padding, and 2K jumbo packets (2048 byte) are supported.

Big, little, and mixed endian support provides independent control over register, descriptor, and buffer endianness. This feature enables easy integration into various ARM/MIPS/PowerPC designs.

LAN9420/LAN9420i supports the PCI Bus Power Management Interface Specification Revision 1.1 and provides the optional ability to generate wake events in the D3cold state when Vaux is available. Wake on LAN, wake on link status change (energy detect), and magic packet wakeup detection are also supported, allowing for a range of power management options.

LAN9420/LAN9420i contains an EEPROM controller for connection to an optional EEPROM. This allows for the automatic loading of static configuration data upon power-up or reset. When connected, the EEPROM can be configured to load a predetermined MAC address, the PCI SSID, and the PCI SVID of LAN9420/LAN9420i.

In addition to the primary functionality described above, LAN9420/LAN9420i provides additional features designed for extended functionality. These include a multipurpose 16-bit configurable General Purpose Timer (GPT), a Free-Run Counter, a 3-pin configurable GPIO/LED interface, and 2 GPO pins. All aspects of LAN9420/LAN9420i are managed via a set of memory mapped control and status registers.

LAN9420/LAN9420i's performance and features make it an ideal solution for many applications in the consumer electronics, enterprise, and industrial automation markets. Targeted applications include: set top boxes (cable, satellite and IP), digital televisions, digital video recorders, home gateways, digital media clients/servers, industrial automation systems, industrial single board PCs, and kiosk/POS enterprise equipment.

1.3 PCI Bridge

LAN9420/LAN9420i implements a PCI Local Bus Specification Revision 3.0 compliant interface, supporting the PCI Bus Power Management Interface Specification Revision 1.1. It provides the PCI Configuration Space Control and Status registers used to configure LAN9420/LAN9420i for PCI device operation. Please refer to [Section 3.2, "PCI Bridge \(PCIB\)," on page 23](#) for more information.

1.4 DMA Controller

The DMA controller consists of independent Transmit and Receive engines and a control and status register (CSR) space. The Transmit Engine transfers data from Host memory to the MAC Interface Layer (MIL) while the Receive Engine transfers data from the MIL to Host memory. The controller utilizes descriptors to efficiently move data from source to destination with minimal processor intervention. Descriptors are DWORD aligned data structures in system memory that inform the DMA controller of the location of data buffers in Host memory and also provide a mechanism for communicating the status to the Host CPU. The DMA controller has been designed for packet-oriented data transfer, such as frames in Ethernet. Zero copy DMA transfer is supported. Copy operations for the purpose of data re-alignment are not required in the case where buffers are fragmented or not aligned to a DWORD boundary. The controller can be programmed to interrupt the Host on the occurrence of particular events, such as frame transmit or receive transfer completed, and other normal, as well as error, conditions. Please refer to [Section 3.4, "DMA Controller \(DMAC\)," on page 38](#) for more information.

1.5 Ethernet MAC

The transmit and receive data paths are separate within the 10/100 Ethernet MAC, allowing the highest performance, especially in full duplex mode. The data paths connect to the PCI Bridge via a DMA engine. The MAC also implements a CSR space used by the Host to obtain status and control its operation. The MAC Interface Layer (MIL), within the MAC, contains a 2K Byte transmit and receive FIFO. The MIL supports store and forward and operate on second frame mode for minimum inter-packet gap. Please refer to [Section 3.5, "10/100 Ethernet MAC," on page 53](#) for more information.

1.6 Ethernet PHY

The PHY implements an IEEE 802.3 physical layer for twisted pair Ethernet applications. It can be configured for either 100 Mbps (100BASE-TX) or 10 Mbps (10BASE-T) Ethernet operation in either full or half duplex configurations. The PHY block includes support for auto-negotiation, auto-polarity correction and Auto-MDIX. Minimal external components are required for the utilization of the integrated PHY. Please refer to [Section 3.6, "10/100 Ethernet PHY," on page 64](#) for more information.

1.7 System Control Block

The System Control Block provides the following additional elements for system operation. These elements are controlled via its System Control and Status Registers (SCSR). Please refer to [Section 3.3, "System Control Block \(SCB\)," on page 28](#) for more information.

1.7.1 Interrupt Controller

The Interrupt Controller (INT) can be programmed to issue a PCI interrupt to the Host on the occurrence of various events. Please refer to [Section 3.3.1, "Interrupt Controller," on page 28](#) for more information.

1.7.2 PLL and Power Management

LAN9420/LAN9420i interfaces with a 25MHz crystal oscillator from which all internal clocks, with the exception of PCI clock, are generated. The internal clocks are all generated by the PLL and Power Management blocks. Various power savings modes exist that allow for the clocks to be shut down. These modes are defined by the power state of the PCI function. Please refer to [Section 3.7, "Power Management,"](#) on page 74 for more information.

1.7.3 EEPROM Controller

LAN9420/LAN9420i provides support for an optional EEPROM via the EEPROM Controller. Please refer to [Section 3.3.5, "EEPROM Controller \(EPC\),"](#) on page 31 for more information.

1.7.4 GPIO/LED Controller

The 3-bit GPIO and 2-bit GPO (Multiplexed on the LED and EEPROM Pins) interface is managed by the GPIO/LED Controller. It is accessible via the System Control and Status Registers (SCSR). The GPIO signals can function as inputs, push-pull outputs and open drain outputs. The GPIOs can also be configured to trigger interrupts with programmable polarity. The GPOs are outputs only and have no means of generating interrupts.

Please refer to [Section 4.2.5, "General Purpose Input/Output Configuration Register \(GPIO_CFG\),"](#) on page 93 for more information.

1.7.5 General Purpose Timer

The General Purpose Timer has no dedicated function within LAN9420/LAN9420i and may be programmed to issue a timed interrupt. Please refer to [Section 3.3.3, "General Purpose Timer \(GPT\),"](#) on page 30 for more information.

1.7.6 Free Run Counter

The Free Run Counter has no dedicated function within LAN9420/LAN9420i and may be used by the software drivers as a timebase. Please refer to [Section 3.3.4, "Free-Run Counter \(FRC\),"](#) on page 31 for more information.

1.8 Control and Status Registers (CSR)

LAN9420/LAN9420i's functions are controlled and monitored by the Host via the Control and Status Registers (CSR). This register space includes registers that control and monitor the DMA controller (DMA Control and Status Registers - DCSR), the MAC (MAC Control and Status Registers - MCSR), the PHY (accessed indirectly through the MAC via the MII_ACCESS and MII_DATA registers), and the elements of the System Control Block via the System Control and Status Registers (SCSR). The CSR may be accessed via I/O or memory operations. Big or Little Endian access is also configurable.

Chapter 2 Pin Description and Configuration

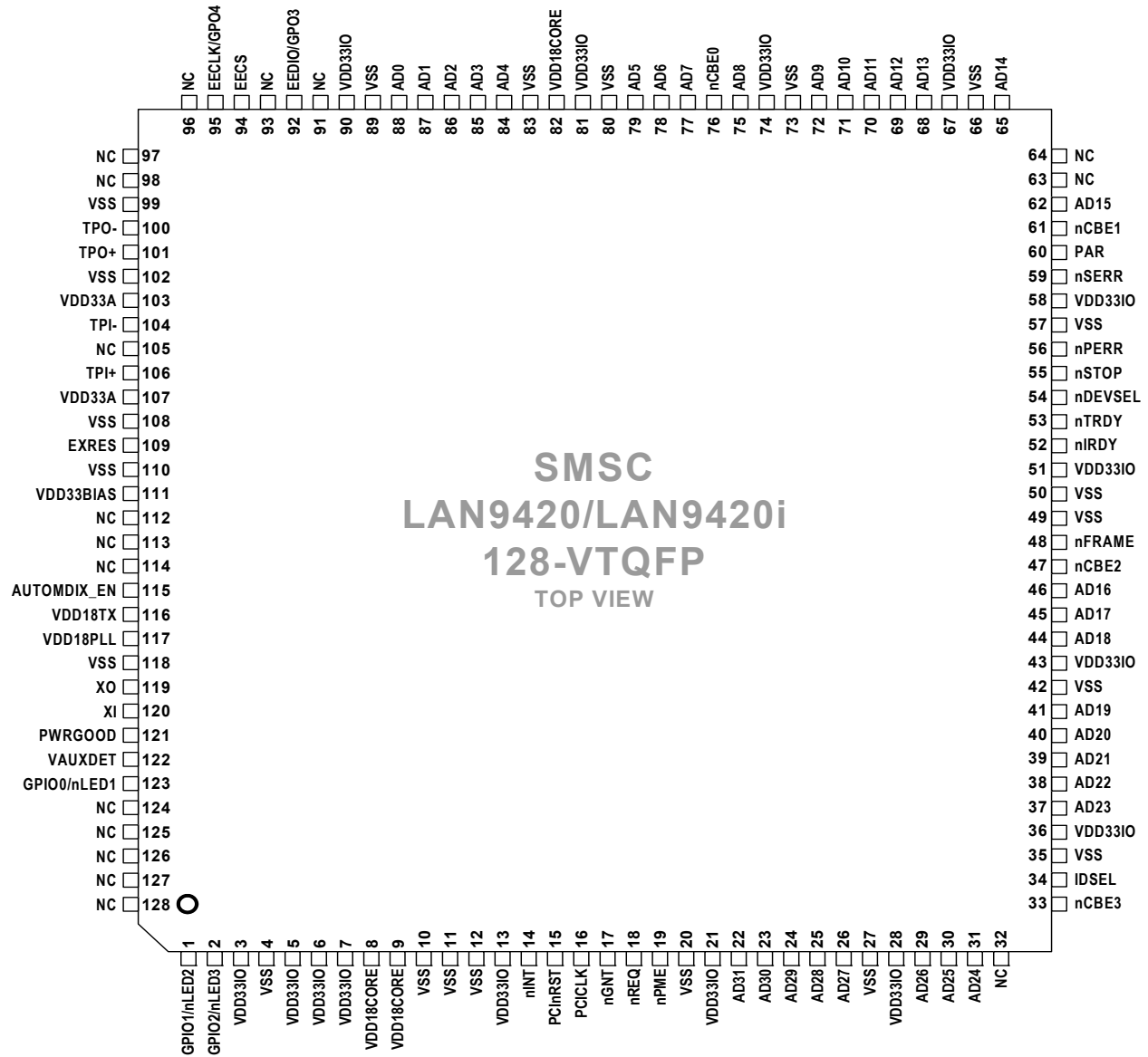

NOTE: When HP Auto-MDIX is activated, the TPO+/- pins function as TPI+/- and vice-versa.

Figure 2.1 LAN9420/LAN9420i 128-VTQFP (Top View)

2.1 Pin List

Table 2.1 PCI Bus Interface Pins

NUM PINS	NAME	SYMBOL	BUFFER TYPE	DESCRIPTION
1	PCI Clock In	PCICLK	IS	PCI Clock In: 0 to 33MHz PCI Clock Input.
1	PCI Frame	nFRAME	IPCI/ OPCI	PCI Cycle Frame
32	PCI Address and Data Bus	AD[31:0]	IPCI/ OPCI	PCI Address and Data Bus
1	PCI Reset	PCInRST	IS	PCI Reset
4	PCI Bus Command and Byte Enables	nCBE[3:0]	IPCI/ OPCI	PCI Bus Command and Byte Enables
1	PCI Initiator Ready	nIRDY	IPCI/ OPCI	PCI Initiator Ready
1	PCI Target Ready	nTRDY	IPCI/ OPCI	PCI Target Ready
1	PCI Stop	nSTOP	IPCI/ OPCI	PCI Stop
1	PCI Device Select	nDEVSEL	IPCI/ OPCI	PCI Device Select
1	PCI Parity	PAR	IPCI/ OPCI	PCI Parity
1	PCI Parity Error	nPERR	IPCI/ OPCI	PCI Parity Error
1	PCI System Error	nSERR	IPCI/ OPCI	PCI System Error
1	PCI Interrupt	nINT	OPCI	PCI Interrupt Note: This pin is an open drain output.
1	PCI IDSEL	IDSEL	IPCI	PCI IDSEL
1	PCI Request	nREQ	OPCI	PCI Request Note: This pin is a tri-state output.
1	PCI Grant	nGNT	IPCI	PCI Grant
1	PCI Power Management Event	nPME	OPCI	PCI Power Management Event Note: This pin is an open drain output.
1	Power Good	PWRGOOD	IS (PD)	PCI Bus Power Good: This pin is used to sense the presence of PCI bus power during the D3 power management state. Note: This pin is pulled low through an internal pull-down resistor
1	V _{AUX} Detection	VAUXDET	IS (PD)	PCI Auxiliary Voltage Sense: This pin is used to sense the presence of a 3.3V auxiliary supply in order to define the PME support available. Note: This pin is pulled low through an internal pull-down resistor

Table 2.2 EEPROM

NUM PINS	NAME	SYMBOL	BUFFER TYPE	DESCRIPTION
1	EEPROM Data	EEDIO	IS/O8	EEPROM Data: This bi-directional pin can be connected to an optional serial EEPROM DIO.
	GPO3	GPO3	O8	General Purpose Output 3: This pin can also function as a general purpose output. The EECS pin is deasserted so as to never unintentionally access the serial EEPROM.
	TX_EN	TX_EN	O8	TX_EN Signal Monitor: This pin can also be configured to monitor the TX_EN signal on the internal MII port. The EECS pin is deasserted so as to never unintentionally access the serial EEPROM.
	TX_CLK	TX_CLK	O8	TX_CLK Signal Monitor: This pin can also be configured to monitor the TX_CLK signal on the internal MII port. The EECS pin is deasserted so as to never unintentionally access the serial EEPROM.
1	EEPROM Chip Select	EECS	O8	Serial EEPROM Chip Select.
1	EEPROM Clock	EECLK	IS/O8 (PU) Note 2.1	EEPROM Clock: Serial EEPROM Clock pin
	GPO4	GPO4	O8	General Purpose Output 4: This pin can also function as a general purpose output. The EECS pin is deasserted so as to never unintentionally access the serial EEPROM.
	RX_DV	RX_DV	O8	RX_DV Signal Monitor: This pin can also be configured to monitor the RX_DV signal on the internal MII port. The EECS pin is deasserted so as to never unintentionally access the serial EEPROM.
	RX_CLK	RX_CLK	O8	RX_CLK Signal Monitor: This pin can also be configured to monitor the RX_CLK signal on the internal MII port. The EECS pin is deasserted so as to never unintentionally access the serial EEPROM.

Note 2.1 This pin is used for factory testing and is latched on power up. This pin is pulled high through an internal resistor and must not be pulled low externally. This pin must be augmented with an external resistor when connected to a load. The value of the resistor must be such that the pin reaches its valid level before de-assertion of PCInRST following power up. The “IS” input buffer type is enabled only during power up. The “IS” input buffer type is disabled at all other times.

Table 2.3 GPIO and LED Pins

NUM PINS	NAME	SYMBOL	BUFFER TYPE	DESCRIPTION
1	General Purpose I/O data 0	GPIO0	IS/O12/ OD12	General Purpose I/O data 0: This general-purpose pin is fully programmable as either push-pull output, open-drain output or input by writing the GPIO_CFG configuration register in the SCSR. GPIO pins are Schmitt-triggered inputs.
	nLED1 (Speed Indicator)	nLED1	OD12	nLED1 (Speed Indicator): This pin can also function as the Ethernet speed indicator LED and is driven low when the operating speed is 100Mbps, during auto-negotiation, and when the cable is disconnected. This pin is driven high only during 10Mbps operation.
1	General Purpose I/O data 1	GPIO1	IS/O12/ OD12	General Purpose I/O data 1: This general-purpose pin is fully programmable as either push-pull output, open-drain output or input by writing the GPIO_CFG configuration register in the SCSR. GPIO pins are Schmitt-triggered inputs.
	nLED2 (Link & Activity Indicator)	nLED2	OD12	nLED2 (Link & Activity Indicator): This pin can also function as the Ethernet Link and Activity Indicator LED and is driven low (LED on) when LAN9420/LAN9420i detects a valid link. This pin is pulsed high (LED off) for 80mS whenever transmit or receive activity is detected. This pin is then driven low again for a minimum of 80mS, after which time it will repeat the process if TX or RX activity is detected. Effectively, LED2 is activated solid for a link. When transmit or receive activity is sensed, LED2 will flash as an activity indicator.
1	General Purpose I/O data 2	GPIO2	IS/O12/ OD12	General Purpose I/O data 2: This general-purpose pin is fully programmable as either push-pull output, open-drain output or input by writing the GPIO_CFG configuration register in the SCSR. GPIO pins are Schmitt-triggered inputs.
	nLED3 (Full-Duplex Indicator)	nLED3	OD12	nLED3 (Full-Duplex Indicator): This pin can also function as the Ethernet Full-Duplex Indicator LED and is driven low when the link is operating in full-duplex mode.

Table 2.4 Configuration Pins

NUM PINS	NAME	SYMBOL	BUFFER TYPE	DESCRIPTION
1	AutoMDIX Enable	AUTOMDIX_EN	IS (PU)	AutoMDIX Enable: Enables Auto-MDIX. Pull high or leave unconnected to enable Auto-MDIX, pull low to disable Auto-MDIX.

Table 2.5 PLL and Ethernet PHY Pins

NUM PINS	NAME	SYMBOL	BUFFER TYPE	DESCRIPTION
1	Crystal Input	XI	ICLK	Crystal Input: External 25MHz crystal input. This pin can also be driven by a single-ended clock oscillator. When this method is used, XO should be left unconnected.
1	Crystal Output	XO	OCLK	Crystal Output: External 25MHz crystal output.
1	Ethernet TX Data Out Negative	TPO-	AIO	Ethernet Transmit Data Out Negative: The transmit data outputs may be swapped internally with receive data inputs when Auto-MDIX is enabled.
1	Ethernet TX Data Out Positive	TPO+	AIO	Ethernet Transmit Data Out Positive: The transmit data outputs may be swapped internally with receive data inputs when Auto-MDIX is enabled.
1	Ethernet RX Data In Negative	TPI-	AIO	Ethernet Receive Data In Negative: The receive data inputs may be swapped internally with transmit data outputs when Auto-MDIX is enabled.
1	Ethernet RX Data In Positive	TPI+	AIO	Ethernet Receive Data In Positive: The receive data inputs may be swapped internally with transmit data outputs when Auto-MDIX is enabled.
1	External PHY Bias Resistor	EXRES	AI	External PHY Bias Resistor: Used for the internal PHY bias circuits. Connect to an external 12.4K 1.0% resistor to ground.

Table 2.6 Power and Ground Pins

NUM PINS	NAME	SYMBOL	BUFFER TYPE	DESCRIPTION
2	+3.3V Analog Power Supply	VDD33A	P	+3.3V Analog Power Supply Refer to the LAN9420/LAN9420i application note for connection information.
1	+1.8V PLL Power Supply	VDD18PLL	P	+1.8V PLL Power Supply: This pin must be connected to VDD18CORE for proper operation. Refer to the LAN9420/LAN9420i application note for additional connection information.
1	+1.8V TX Power Supply	VDD18TX	P	+1.8V Transmitter Power Supply: This pin must be connected to VDD18CORE for proper operation. Refer to the LAN9420/LAN9420i application note for additional connection information.
1	+3.3V Master Bias Power Supply	VDD33BIAS	P	+3.3V Master Bias Power Supply Refer to the LAN9420/LAN9420i application note for additional connection information.
15	+3.3V I/O Power	VDD33IO	P	+3.3V Power Supply for I/O Pins and Internal Regulator Refer to the LAN9420/LAN9420i application note for additional connection information.
21	Ground	VSS	P	Common Ground for I/O Pins, Core, and Analog Circuitry
3	+1.8V Core Power	VDD18CORE	P	Digital Core +1.8V Power Supply Output from Internal Regulator Refer to the LAN9420/LAN9420i application note for additional connection information.

Table 2.7 No-Connect Pins

NUM PINS	NAME	SYMBOL	BUFFER TYPE	DESCRIPTION
17	No Connect	NC	-	No Connect: These pins must be left floating for normal device operation.

Table 2.8 128-VTQFP Package Pin Assignments

PIN NUM	PIN NAME	PIN NUM	PIN NAME	PIN NUM	PIN NAME	PIN NUM	PIN NAME
1	GPIO1/nLED2	33	nCBE3	65	AD14	97	NC
2	GPIO2/nLED3	34	IDSEL	66	VSS	98	NC
3	VDD33IO	35	VSS	67	VDD33IO	99	VSS
4	VSS	36	VDD33IO	68	AD13	100	TPO-
5	VDD33IO	37	AD23	69	AD12	101	TPO+
6	VDD33IO	38	AD22	70	AD11	102	VSS
7	VDD33IO	39	AD21	71	AD10	103	VDD33A
8	VDD18CORE	40	AD20	72	AD9	104	TPI-
9	VDD18CORE	41	AD19	73	VSS	105	NC
10	VSS	42	VSS	74	VDD33IO	106	TPI+
11	VSS	43	VDD33IO	75	AD8	107	VDD33A
12	VSS	44	AD18	76	nCBE0	108	VSS
13	VDD33IO	45	AD17	77	AD7	109	EXRES
14	nINT	46	AD16	78	AD6	110	VSS
15	PCInRST	47	nCBE2	79	AD5	111	VDD33BIAS
16	PCICLK	48	nFRAME	80	VSS	112	NC
17	nGNT	49	VSS	81	VDD33IO	113	NC
18	nREQ	50	VSS	82	VDD18CORE	114	NC
19	nPME	51	VDD33IO	83	VSS	115	AUTOMDIX_EN
20	VSS	52	nIRDY	84	AD4	116	VDD18TX
21	VDD33IO	53	nTRDY	85	AD3	117	VDD18PLL
22	AD31	54	nDEVSEL	86	AD2	118	VSS
23	AD30	55	nSTOP	87	AD1	119	XO
24	AD29	56	nPERR	88	AD0	120	XI
25	AD28	57	VSS	89	VSS	121	PWRGOOD
26	AD27	58	VDD33IO	90	VDD33IO	122	VAUXDET
27	VSS	59	nSERR	91	NC	123	GPIO0/nLED1
28	VDD33IO	60	PAR	92	EEDIO/GPO3	124	NC
29	AD26	61	nCBE1	93	NC	125	NC
30	AD25	62	AD15	94	EECS	126	NC
31	AD24	63	NC	95	EECLK/GPO4	127	NC
32	NC	64	NC	96	NC	128	NC

2.2 Buffer Types

BUFFER TYPE	DESCRIPTION
IS	Schmitt-triggered Input
O8	Output with 8mA sink and 8mA source current
O12	Output with 12mA sink and 12mA source current
OD12	Open-drain output with 12mA sink current
IPCI	PCI compliant Input
OPCI	PCI compliant Output
PU	50uA (typical) internal pull-up. Unless otherwise noted in the pin description, internal pull-ups are always enabled. Note: Internal pull-up resistors prevent unconnected inputs from floating. Do not rely on internal resistors to drive signals external to LAN9420/LAN9420i. When connected to a load that must be pulled high, an external resistor must be added.
PD	50uA (typical) internal pull-down. Unless otherwise noted in the pin description, internal pull-downs are always enabled. Note: Internal pull-down resistors prevent unconnected inputs from floating. Do not rely on internal resistors to drive signals external to LAN9420/LAN9420i. When connected to a load that must be pulled low, an external resistor must be added.
AI	Analog Input
AIO	Analog bi-directional
ICLK	Crystal oscillator input
OCLK	Crystal oscillator output
P	Power and Ground pin

Chapter 3 Functional Description

3.1 Functional Overview

The LAN9420/LAN9420i Ethernet Controller consists of five major functional blocks. These blocks are:

- [PCI Bridge \(PCIB\)](#)
- [System Control Block \(SCB\)](#)
- [DMA Controller \(DMAC\)](#)
- [10/100 Ethernet MAC](#)
- [10/100 Ethernet PHY](#)

The following sections discuss the features of each block. A block diagram of LAN9420/LAN9420i is shown in [Figure 1.2 LAN9420/LAN9420i Internal Block Diagram on page 11](#).

3.2 PCI Bridge (PCIB)

The PCI Bridge (PCIB) facilitates LAN9420/LAN9420i's operation on a PCI bus as a device. It has the following features:

PCI Master Interface: This interface connects LAN9420/LAN9420i to the PCI bus when it is functioning as a PCI Master. It is used by the DMA engines to directly access the PCI Host's memory.

PCI Target Interface: This interface connects LAN9420/LAN9420i to the PCI bus when it is functioning as a PCI Target. It provides access to PCI Configuration Space Control and Status Register (CONFIG CSR), and access to the Control and Status Registers (CSR) via I/O or Non-Prefetchable (NP) memory accesses. In addition, Big/Little Endian support for the registers may be selected.

PCI Power Management Support: LAN9420/LAN9420i supports PCI Bus Power Management Interface Specification Rev. 1.1. Refer to [Section 3.7, "Power Management," on page 74](#) for more information.

Interrupt Gating Logic: This logic controls assertion of the nINT signal to the Host system.

PCI Configuration Space Control and Status Registers (CONFIG CSR): The Host system controls and monitors the LAN9420/LAN9420i device using registers in this space.

3.2.1 PCI Bridge (PCIB) Block Diagram

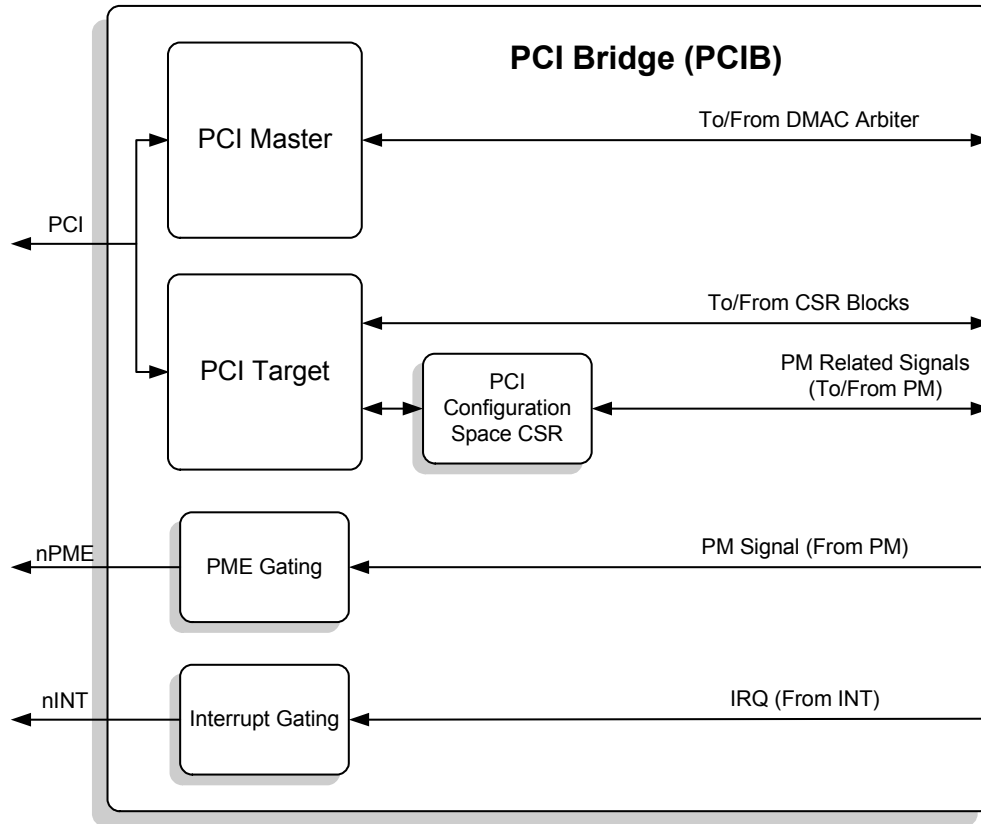

Figure 3.1 PCI Bridge Block Diagram

3.2.2 PCI Interface Environments

The PCIB supports only Device operation. It functions as a simple bridge, permitting LAN9420/LAN9420i to act as a master/target PCI device on the PCI bus. The Host performs PCI arbitration and is responsible for initializing configuration space for all devices on the bus. Figure 3.2 illustrates Device operation.

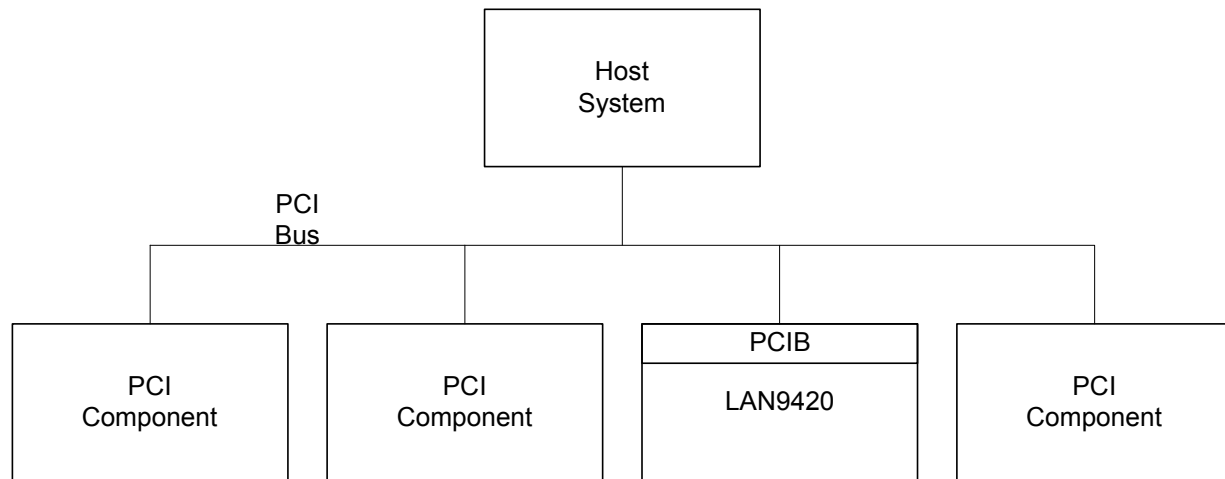

Figure 3.2 Device Operation

3.2.3 PCI Master Interface

The PCI Master Interface is used by the DMA engines to directly access the PCI Host's memory. It is used by the TX and RX DMA Controllers to access Host descriptor ring elements and Host DMA buffers. No address translation occurs, as these entities are contained within the Host, which allocates them within the flat PCI address space.

3.2.3.1 PCI Master Transaction Errors

In the event of an error during a descriptor read or during a transmit data read, the DMA controller will generate a Master Bus Error Interrupt (MBERR_INT).

When an MBERR_INT is asserted, all subsequent transactions from the DMAC will be aborted. In order to cleanly recover from this condition, a software reset or H/W reset must be performed. A software reset is accomplished by setting the SRST bit of the BUS_MODE register.

Note: It is guaranteed that the MBERR_INT will be reported on the frame upon which the error occurred as follows:

- Errors on descriptor reads will be aborted immediately.
- Errors on TX data will be reported either upon the data or the close descriptor (if the error occurs on the last data transfer).
- DMA RX data and descriptor write operations are posted and will therefore not generate the MBERR_INT.

3.2.4 PCI Target Interface

The PCI target interface implements the address spaces listed in [Table 3.1](#).

Table 3.1 PCI Address Spaces

SPACE	SIZE	RESOURCE
Configuration	256 bytes	PCI standard and PCIB-specific registers
BAR0...BAR2		RESERVED
BAR3	1 KB	Control and Status Registers (Non-prefetchable area)
BAR4	256B	Control and Status Registers (I/O area)
BAR5		RESERVED
Expansion ROM	-	RESERVED

The PCI Configuration space is used to identify PCI Devices, configure memory ranges, and manage interrupts. The Host initializes and configures the PCI Device during a plug-and-play process.

The PCI Target Interface supports 32-bit slave accesses only. Non 32-bit PCI target reads to LAN9420/LAN9420i will result in a full 32-bit read. Non 32-bit PCI target writes to LAN9420/LAN9420i will be silently discarded.

3.2.4.1 PCI Configuration Space Registers

PCI Configuration Space Registers include the standard PCI header registers and PCIB extensions to implement power management control/status registers. See [Section 4.6, "PCI Configuration Space CSR \(CONFIG CSR\)," on page 150](#) for further details. These registers exist in the configuration space.

3.2.4.2 Control and Status Registers (CSR)

The PCI Target Interface allows PCI bus masters to directly access the LAN9420/LAN9420i Control and Status registers via memory or I/O operations. Each set of operations has an associated address range that defines it as follows:

- The non-prefetchable (NP) address range is mapped in BAR3. No data prefetch is performed when serving PCI transactions targeting this address range.
- The I/O address range is mapped in BAR4.

3.2.4.2.1 CSR ENDIANNESS

The Non-Prefetchable address range contains a double mapping of the CSR. These mappings allow the registers to be accessed in little endian or big endian order. [Figure 3.3, "CSR Double Endian Mapping"](#) illustrates the mapping. BA is the base address, as specified by BAR3.

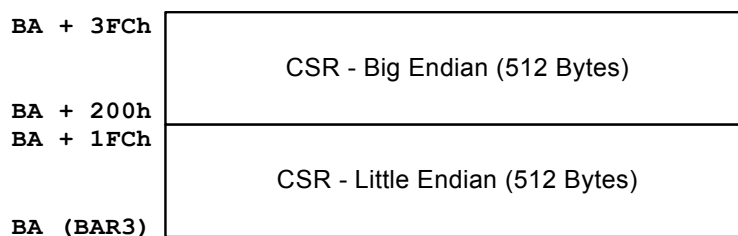

Figure 3.3 CSR Double Endian Mapping

3.2.4.2.2 I/O MAPPING OF CSR

The I/O BAR (BAR4) is double mapped over the CSR space with the non-prefetchable area. The CSR big endian space is disabled, as the Host processors (Intel x86) that use the I/O BAR are little endian.

Note: A comparison of [Figure 3.3](#) with [Figure 3.4](#) indicates only the first 256 bytes of CSR little endian space is addressable via the I/O BAR.

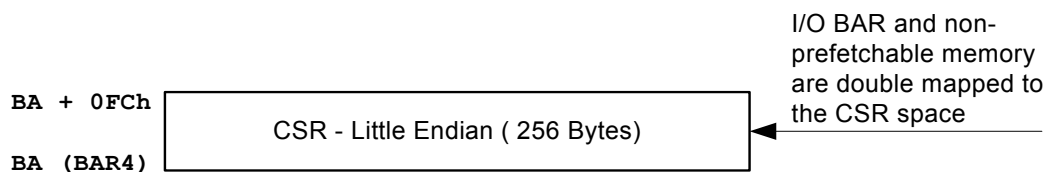

Figure 3.4 I/O Bar Mapping

3.2.4.3 PCI Target Interface Transaction Errors

If the Host system attempts an unsupported cycle type when accessing the CSR via the PCI Target Interface, a slave transaction error will result and the PCI Target Interface will generate a Slave Bus Error Interrupt (SBERR_INT), if enabled. CSR may only be read or written as DWORD quantities and any other type of access is unsupported and will result in the assertion of SBERR_INT. Non-DWORD reads will return a DWORD while non-DWORD writes are silently discarded. In order to cleanly recover from this condition, a software reset or H/W reset must be performed. A software reset is accomplished by setting the SRST bit of the BUS_MODE register.

3.2.4.4 PCI Discard Timer

When the PCI master performs a read of LAN9420/LAN9420i, the PCI Bridge will fetch the data and acknowledge the PCI transfer when data is available. If the PCI master malfunctions and does not complete the transaction within 32768 PCI clocks, LAN9420/LAN9420i will flush the data to prevent a potential bus lock-up.

3.2.5 Interrupt Gating Logic

One set of interrupts exists: PCI Host interrupts (PCI interrupts from LAN9420/LAN9420i to the PCI Host). PCI Host interrupts result from the assertion of the internal IRQ signal from the Interrupt Controller. Refer to [Section 3.3.1, "Interrupt Controller," on page 28](#) for sources of this interrupt. [Figure 3.5](#) illustrates how interrupts are sourced by the Interrupt Controller to the PCIB and are propagated to the Host. The Interrupt is passed on to the Host only when the Host has enabled it by setting bit 10 in the PCI Device Command Register. The Host may obtain interrupt status by reading

Bit 3 of the PCI Device Status Register. The PCI Device Status Register and PCI Device Command Register are standard registers in PCI Configuration Space. Please refer to [Section 4.6, "PCI Configuration Space CSR \(CONFIG CSR\)," on page 150](#) for details.

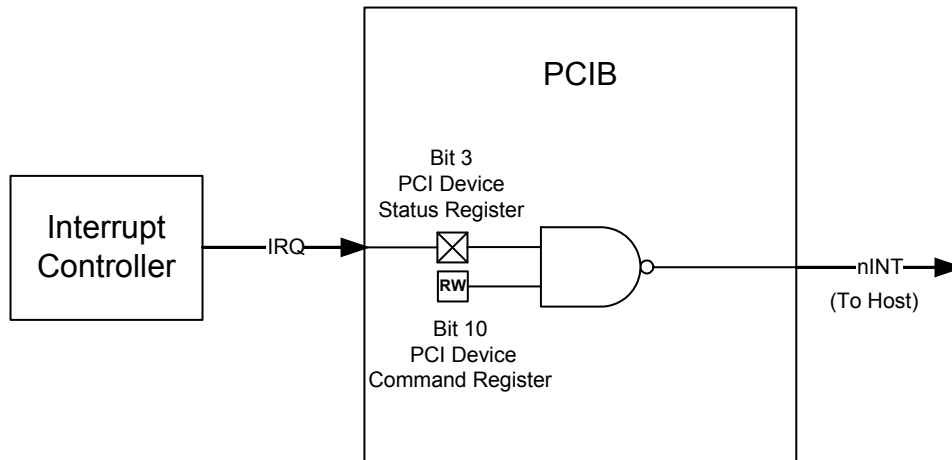

Figure 3.5 Interrupt Generation

3.3 System Control Block (SCB)

The System Control Block includes an interrupt controller, wake detection logic, a general-purpose timer, a free-run counter and system control and status registers.

Interrupt Controller: The interrupt controller can be programmed to interrupt the Host system applications on the occurrence of various events. The interrupt is routed to the Host system via the PCIB.

Wake Detection Logic: This logic detects the occurrence of an enabled wake event and asserts the PCI nPME signal, if enabled.

General Purpose Timer (GPT): The general purpose timer can be configured to generate a system interrupt upon timeout.

Free-Run Counter (FRC): A 32-bit free-running counter with a 160 ns resolution.

EEPROM Controller (EPC): An optional, external, Serial EEPROM may be used to store the default values for the MAC address, PCI Subsystem ID, and PCI Subsystem Vendor ID. In addition, it may also be used for general data storage. The EEPROM controller provides LAN9420/LAN9420i access to the EEPROM and permits the Host to read, write and erase its contents.

System Control and Status Registers (SCSR): These registers control system functions that are not specific to the DMAC, MAC or PHY.

3.3.1 Interrupt Controller

The Interrupt Controller handles the routing of all internal interrupt sources. Interrupts enter the controller from various modules within LAN9420/LAN9420i. The Interrupt Controller drives the interrupt request (IRQ) output to the PCI Bridge. The Interrupt Controller is capable of generating PCI interrupts on detection of the following internal events:

- DMAC interrupt request (DMAC_INT)
- PHY interrupt request (PHY_INT)

Datasheet

- General-purpose timer interrupt (GPT_INT)
- General purpose Input/Output interrupt (GPIOx_INT)
- Software interrupt (SW_INT)
- Master bus error interrupt (MBERR_INT)
- Slave bus error interrupt (SBERR_INT)
- Wake event detection (WAKE_INT)

A Block diagram of the Interrupt Controller is shown in [Figure 3.6](#).

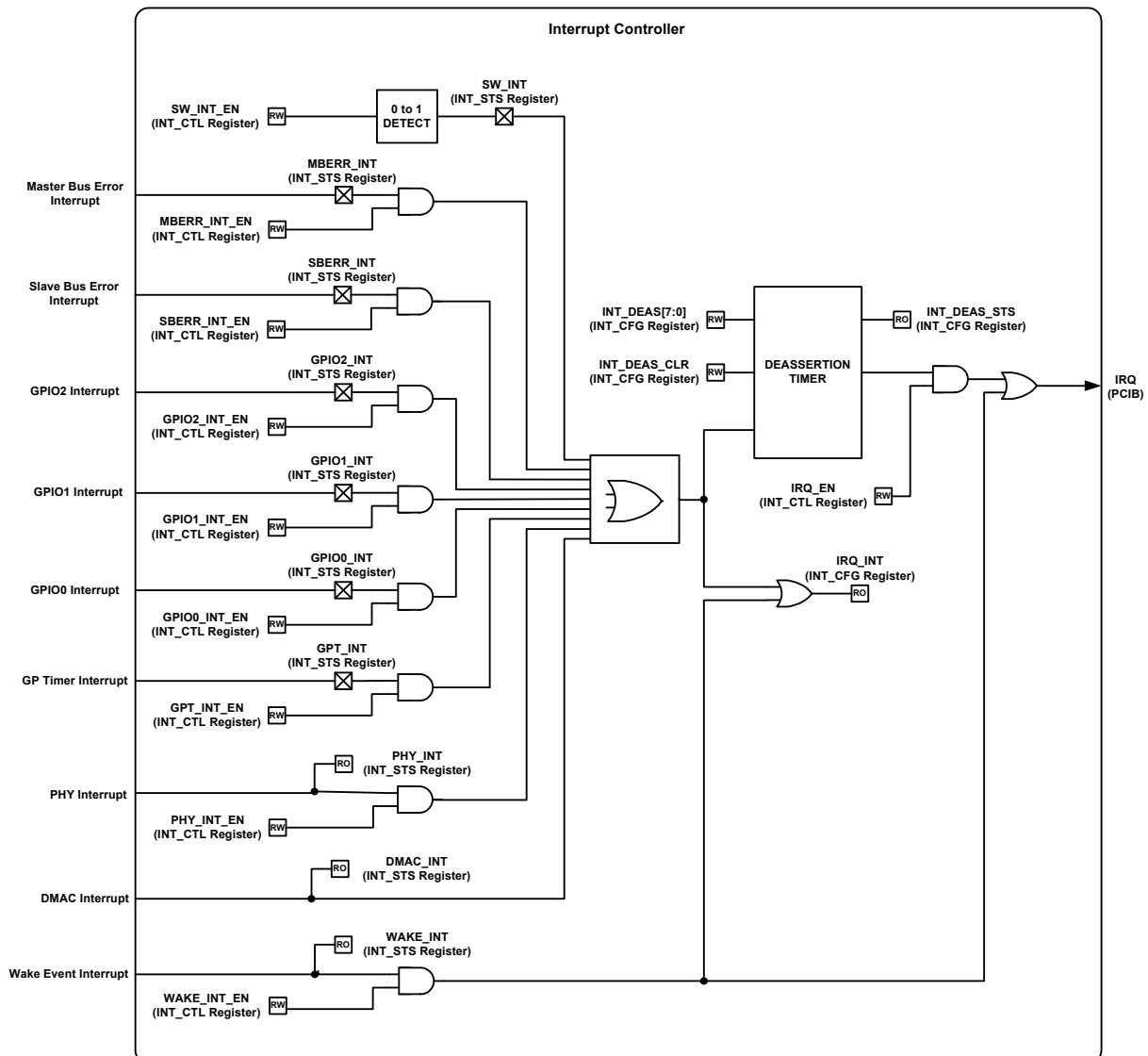

Figure 3.6 Interrupt Controller Block Diagram

The Interrupt Controller control and status register are contained within the System Control and Status Registers (SCSR) block. The interrupt status register (INT_STS) reflects the current state of the interrupt sources prior to qualification with their associated enables. The SW_INT, MBERR_INT, SBERR_INT, GPIOx_INT, and GPT_INT are latched, and are cleared through the SCSR block upon a

write of '1' to the corresponding status bit in the INT_STS register. The remaining interrupts are cleared from the source CSR.

The Interrupt Controller receives the wake event detection interrupt (WAKE_INT) from the wake detection logic. If enabled, the wake detection logic is able to generate an interrupt to the PCI Bridge on detection of a MAC wakeup event (Wakeup Frame or Magic Packet), or on an Ethernet link status change (energy detect).

Note: LAN9420/LAN9420i can optionally generate a PCI interrupt in addition to assertion of nPME on detection of a power management event. Generation of a PCI interrupt is not the typical usage.

Unlike the other interrupt sources, the software interrupt (SW_INT) is asserted on a 0-to-1 transition of its enable bit (SW_INT_EN). The DMAC interrupt is enabled in the DMA controller. All other Interrupts are enabled through the INT_EN register. Setting an enable bit high enables the corresponding interrupt as a source of the IRQ.

The Interrupt Controller contains an interrupt de-assertion timer. This timer guarantees a minimum interrupt de-assertion period for the IRQ. The de-assertion timer has a resolution of 10us and is programmable through the INT_CFG_SCSR (refer to [Section 4.2.4, "Interrupt Configuration Register \(INT_CFG\)," on page 92](#)). A setting of all zeros disables the de-assertion timer. The state of the interrupt de-assertion timer is reflected by the interrupt de-assertion timer status bit (INT_DEAS_STS) bit in the IRQ_CFG register. When this bit is set, the de-assertion timer is currently in a de-assertion interval, and, with the exception of the WAKE_INT, all pending interrupts are blocked.

Note: The interrupt de-assertion timer does not affect WAKE_INT. This interrupt event is able to assert IRQ regardless of the state of the de-assertion timer.

The IRQ_INT status bit in the INT_CFG register reflects the aggregate status of all interrupt sources. If this status bit is set, one or more enabled interrupts are active. The IRQ_INT status bit is not affected by the de-assertion timer.

The IRQ output is enabled/disabled by the IRQ_EN enable bit in the INT_CTL register. When this bit is cleared, with the exception of WAKE_INT, all interrupts to the PCI Bridge are disabled. When set, interrupts to the PCI Bridge are enabled.

Note: The IRQ_EN does not affect WAKE_INT. This interrupt event is able to assert IRQ regardless of the state of IRQ_EN.

3.3.2 Wake Event Detection Logic

LAN9420/LAN9420i supports the ability to generate wake interrupts on detection of a Magic Packet, Wakeup Frame or Ethernet link status change (energy detect). When enabled to do so, the wake event detection logic generates an interrupt to the Interrupt Controller. Refer to [Section 3.7.6, "Detecting Power Management Events," on page 81](#) for more information on the wake event interrupt.

Wakeup frame detection must be enabled in the MAC before detection can occur. Likewise, the energy detect interrupt must be enabled in the PHY before this interrupt can be used.

3.3.3 General Purpose Timer (GPT)

The General Purpose Timer is a programmable device that can be used to generate periodic system interrupts. The resolution of this timer is 100uS.

The GP Timer loads the GPT_CNT Register with the value in the GPT_LOAD field and begins counting when the TIMER_EN bit is asserted (1). On a chip-level reset, or when the TIMER_EN bit changes from asserted (1) to de-asserted (0), the GPT_LOAD field is initialized to FFFFh. The GPT_CNT register is also initialized to FFFFh on a reset. Software can write the pre-load value into the GPT_LOAD field at any time (e.g., before or after the TIMER_EN bit is asserted). The GPT Enable bit TIMER_EN is located in the GPT_CFG register.

Once enabled, the GPT counts down either until it reaches 0000h, or until a new pre-load value is written to the GPT_LOAD field. At 0000h, the counter wraps around to FFFFh, asserts the GPT interrupt status bit (GPT_INT) and the GPT interrupt (if the GPT_INT_EN bit is set), and continues counting. GPT_INT is a sticky bit (R/WC). Once the GPT_INT bit is asserted, it can only be cleared by writing a '1' to the bit. The GPT_INT hardware interrupt can only be asserted if the GPT_INT_EN bit is set.

3.3.4 Free-Run Counter (FRC)

The FRC is a simple 32-bit up counter. The FRC counts at fixed rate of 6.25MHz (160nS resolution). When the FRC reaches a value of FFFF_FFFFh, it wraps around to 0000_0000h and continues counting. The FRC is operational in all power states. The FRC has no fixed function in LAN9420/LAN9420i and is ideal for use by drivers as a timebase. The current FRC count is readable in FREE_RUN_SCSR. Please refer to [Section 4.2.10, "Free Run Counter \(FREE_RUN\)," on page 99](#) for more information on this register.

3.3.5 EEPROM Controller (EPC)

LAN9420/LAN9420i may use an optional, external, EEPROM to store the default values for the MAC address, PCI Subsystem ID, and PCI Subsystem Vendor ID. The PCI Subsystem ID and PCI Subsystem Vendor ID are used by the PCI Bridge (PCIB). The MAC address is used as the default Ethernet MAC address and is loaded into the MAC's ADDRH and ADDRL registers. If a properly configured EEPROM is not detected, it is the responsibility of the Host LAN Driver to set the IEEE addresses.

After a system-level reset occurs, LAN9420/LAN9420i will load the default values from a properly configured EEPROM. LAN9420/LAN9420i will not accept PCI target transactions until this process is completed.

The LAN9420/LAN9420i EEPROM controller also allows the Host system to read, write and erase the contents of the Serial EEPROM. The EEPROM controller supports most "93C46" type EEPROMs configured for 128 x 8-bit operation.

3.3.5.1 EEPROM Format

[Table 3.2](#) illustrates the format in which data is stored inside of the EEPROM.

Table 3.2 EEPROM Format

EEPROM BYTE ADDRESS	EEPROM CONTENTS
0	0xA5
1	MAC Address [7:0]
2	MAC Address [15:8]
3	MAC Address [23:16]
4	MAC Address [32:24]
5	MAC Address [39:33]
6	MAC Address [47:40]
7	Subsystem Device ID [7:0]
8	Subsystem Device ID [15:8]

Table 3.2 EEPROM Format (continued)

EEPROM BYTE ADDRESS	EEPROM CONTENTS
9	Subsystem Vendor ID [7:0]
0Ah	Subsystem Vendor ID [15:8]

Note: EEPROM byte addresses past 0Ah can be used to store data for any purpose.

The signature value of 0xA5 is stored at address 0. A different signature value indicates to the EEPROM controller that no EEPROM or an un-programmed EEPROM is attached to LAN9420/LAN9420i. In this case, following default values are used for the Subsystem Device ID (SSID), Subsystem Vendor ID (SSVID), and the MAC address.

Table 3.3 EEPROM Variable Defaults

VARIABLE	DEFAULT
Subsystem ID [15:0]	0x9420
Subsystem Vendor ID [15:0]	0x1055
MAC Address [47:0]	0xFFFF_FFFF_FFFF

3.3.5.2 MAC Address, Subsystem ID, and Subsystem Vendor ID Auto-Load

On a system-level reset, the EEPROM controller attempts to read the first byte of data from the EEPROM (address 00h). If the value A5h is read from the first address, then the EEPROM controller will assume that an external EEPROM is present. The EEPROM controller will then access the next EEPROM byte and send it to the MAC Address register byte 0 (ADDRL[7:0]). This process will be repeated for the next five bytes of the MAC Address, thus fully programming the 48-bit MAC address. The Subsystem ID and Subsystem Vendor ID are similarly extracted from the EEPROM and are used to set the value of the analogous PCI Header registers contained within the PCIB. Once all eleven bytes have been programmed, the “EEPROM Loaded” bit is set in the E2P_CMD register. A detailed explanation of the EEPROM byte ordering with respect to the MAC address is given in [Section 4.4.3, “MAC Address Low Register \(ADDRL\),” on page 125](#).

If an 0xA5h is not read from the first address, the EEPROM controller will end initialization. The default values, as specified in [Table 3.3](#), will then be assumed by the associated registers. It is then the responsibility of the Host LAN driver software to set the IEEE address by writing to the MAC’s ADDRH and ADDRL registers.

3.3.5.3 EEPROM Host Operations

After the EEPROM controller has finished reading (or attempting to read) the EEPROM after a system-level reset, the Host is free to perform other EEPROM operations. EEPROM operations are performed using the EEPROM Command (E2P_CMD) and EEPROM Data (E2P_DATA) registers. [Section 4.2.11, “EEPROM Command Register \(E2P_CMD\),” on page 100](#) provides an explanation of the supported EEPROM operations.

If the EEPROM operation is the “write location” (WRITE) or “write all” (WRAL) commands, the Host must first write the desired data into the E2P_DATA register. The Host must then issue the WRITE or WRAL command using the E2P_CMD register by setting the EPC_CMD field appropriately. If the operation is a WRITE, the EPC_ADDR field in E2P_CMD must also be set to the desired location. The command is executed when the Host sets the EPC_BSY bit high. The completion of the operation is indicated when the EPC_BSY bit is cleared.

Datasheet

If the EEPROM operation is the “read location” (READ) operation, the Host must issue the READ command using the E2P_CMD register with the EPC_ADDR set to the desired location. The command is executed when the Host sets the EPC_BSY bit high. The completion of the operation is indicated when the EPC_BSY bit is cleared, at which time the data from the EEPROM may be read from the E2P_DATA register.

Other EEPROM operations are performed by writing the appropriate command to the E2P_CMD register. The command is executed when the Host sets the EPC_BSY bit high. The completion of the operation is indicated when the EPC_BSY bit is cleared. In all cases, the Host must wait for EPC_BSY to clear before modifying the E2P_CMD register.

Note: The EEPROM device powers-up in the erase/write disabled state. To modify the contents of the EEPROM, the Host must first issue the EWEN command.

If an operation is attempted, and an EEPROM device does not respond within 30mS, LAN9420/LAN9420i will timeout, and the EPC Time-out bit (EPC_TO) in the E2P_CMD register will be set.

Figure 3.7 illustrates the Host accesses required to perform an EEPROM Read or Write operation.

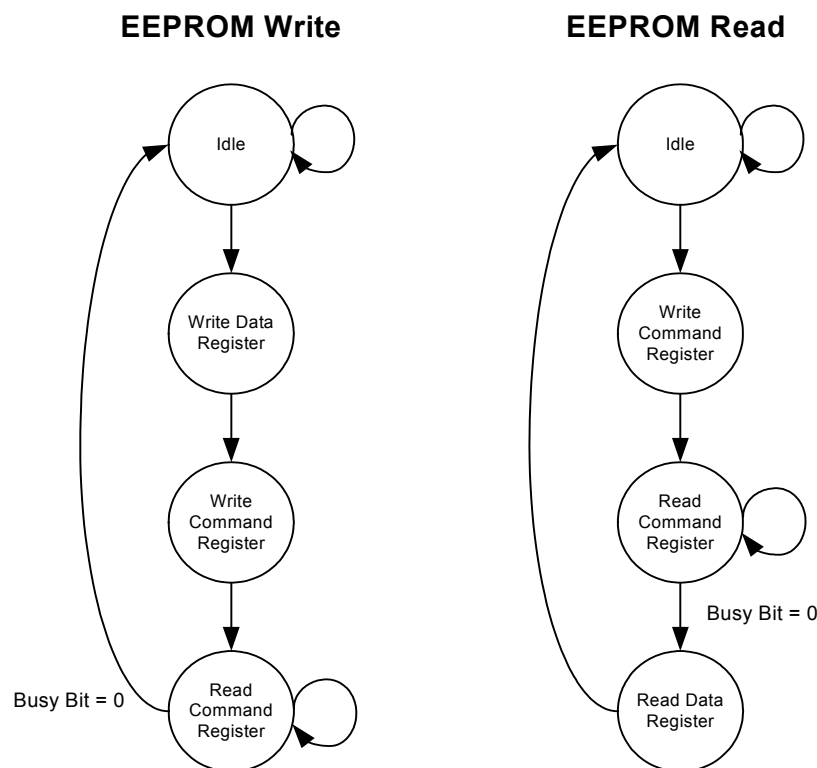

Figure 3.7 EEPROM Access Flow Diagram

The Host can disable the EEPROM interface through the GPIO_CFG register. When the interface is disabled, the EEDIO and ECLK signals can be used as general-purpose outputs, or they may be used to monitor internal MII signals.

3.3.5.3.1 SUPPORTED EEPROM OPERATIONS

The EEPROM controller supports the following EEPROM operations under Host control via the E2P_CMD register. The operations are commonly supported by “93C46” EEPROM devices. A description and functional timing diagram is provided below for each operation. Please refer to the E2P_CMD register description in [Section 4.2.11, "EEPROM Command Register \(E2P_CMD\)," on page 100](#) for E2P_CMD field settings for each command.

ERASE (Erase Location): If erase/write operations are enabled in the EEPROM, this command will erase the location selected by the EPC Address field (EPC_ADDR). The EPC_TO bit is set if the EEPROM does not respond within 30ms.

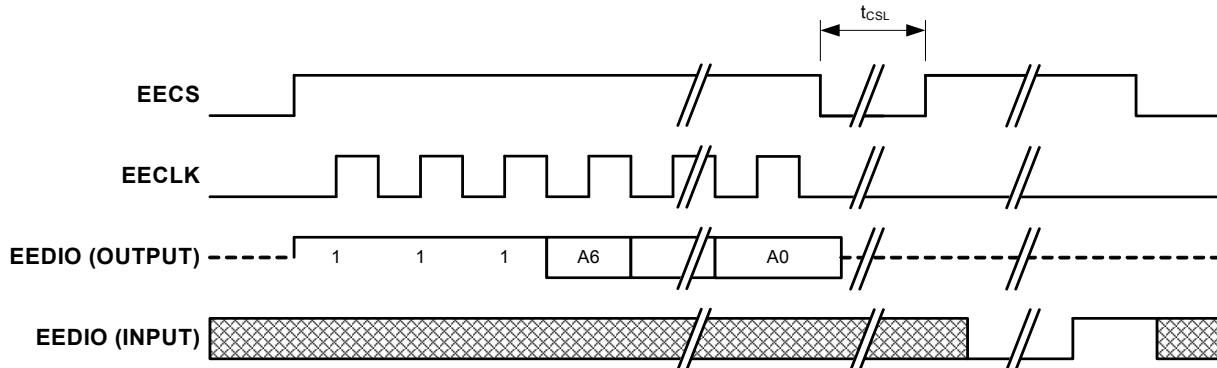
Figure 3.8 EEPROM ERASE Cycle

ERALL (Erase All): If erase/write operations are enabled in the EEPROM, this command will initiate a bulk erase of the entire EEPROM. The EPC_TO bit is set if the EEPROM does not respond within 30ms.

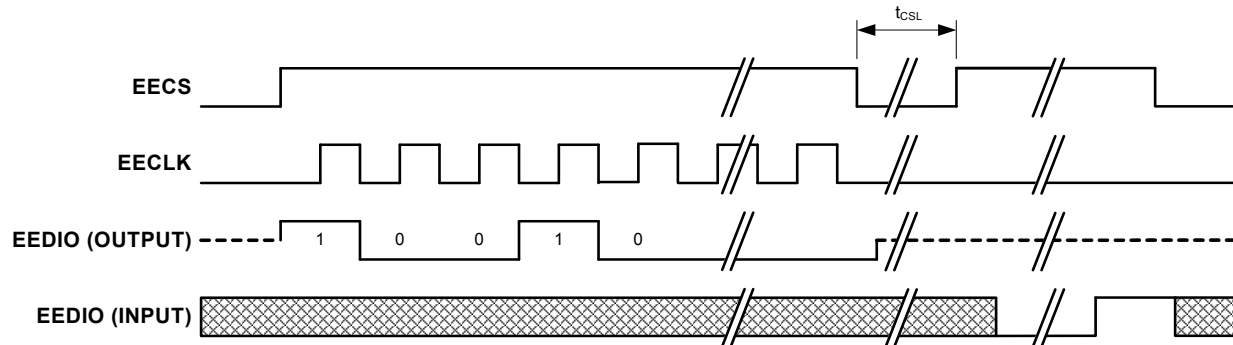
Figure 3.9 EEPROM ERALL Cycle

EWDS (Erase/Write Disable): After issued, the EEPROM will ignore erase and write commands. To re-enable erase/write operations issue the EWEN command.

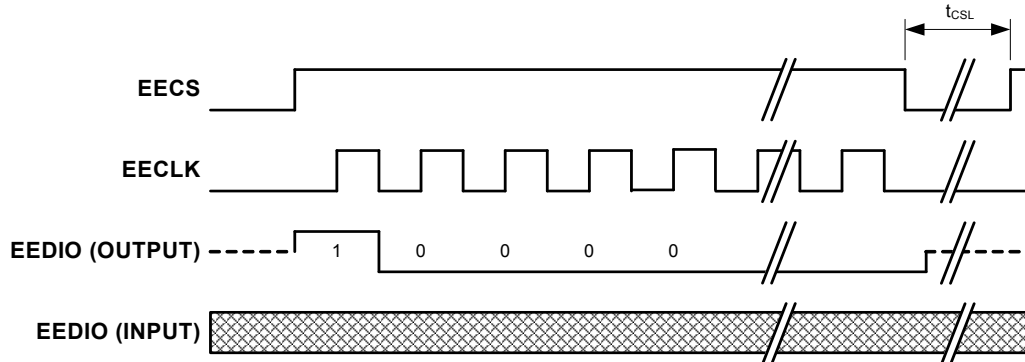

Figure 3.10 EEPROM EWDS Cycle

EWEN (Erase/Write Enable): Enables the EEPROM for erase and write operations. The EEPROM will allow erase and write operations until the "Erase/Write Disable" command is sent, or until power is cycled.

Note: The EEPROM device will power-up in the erase/write-disabled state. Any erase or write operations will fail until an Erase/Write Enable command is issued.

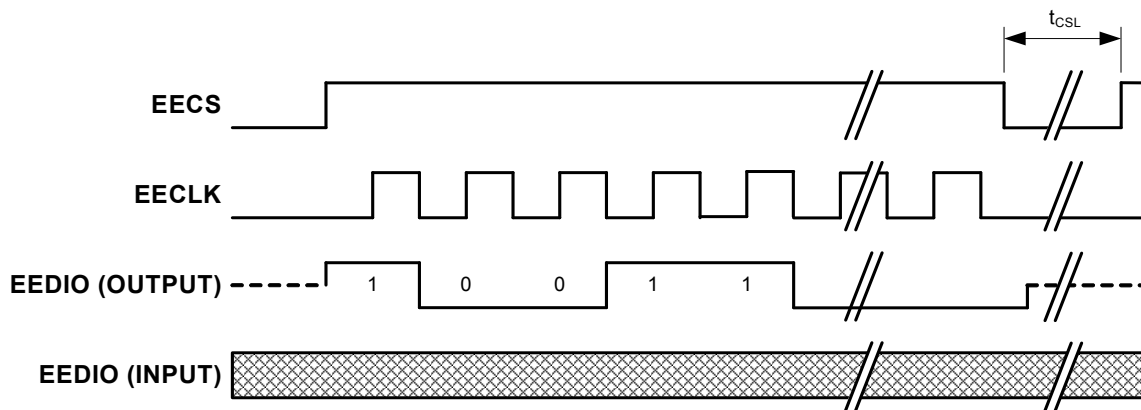

Figure 3.11 EEPROM EWEN Cycle

READ (Read Location): This command will cause a read of the EEPROM location pointed to by EPC Address (EPC_ADDR). The result of the read is available in the E2P_DATA register.

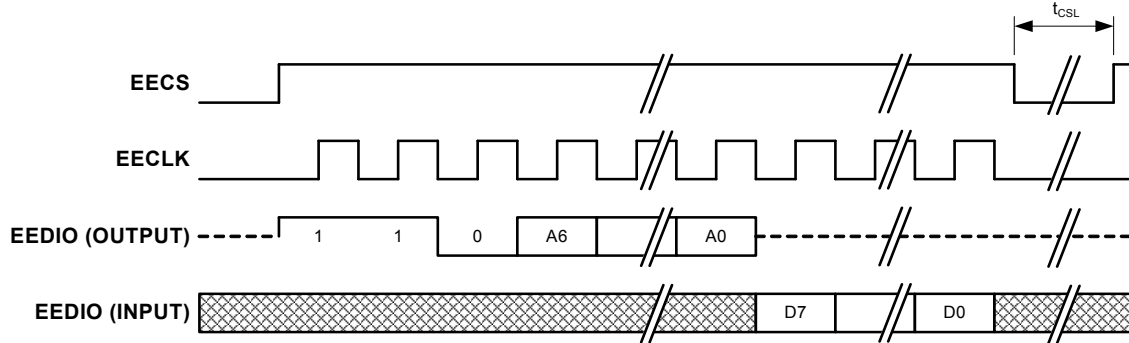

Figure 3.12 EEPROM READ Cycle

WRITE (Write Location): If erase/write operations are enabled in the EEPROM, this command will cause the contents of the E2P_DATA register to be written to the EEPROM location selected by the EPC Address field (EPC_ADDR). The EPC_TO bit is set if the EEPROM does not respond within 30ms.

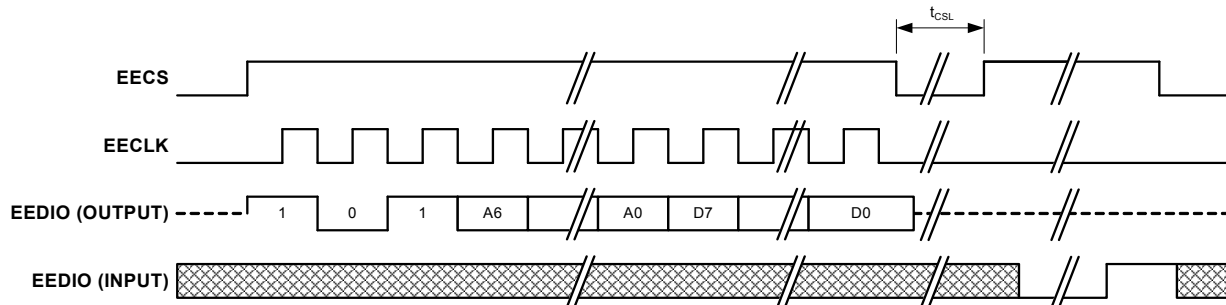

Figure 3.13 EEPROM WRITE Cycle

Datasheet

WRAL (Write All): If erase/write operations are enabled in the EEPROM, this command will cause the contents of the E2P_DATA register to be written to every EEPROM memory location. The EPC_TO bit is set if the EEPROM does not respond within 30ms.

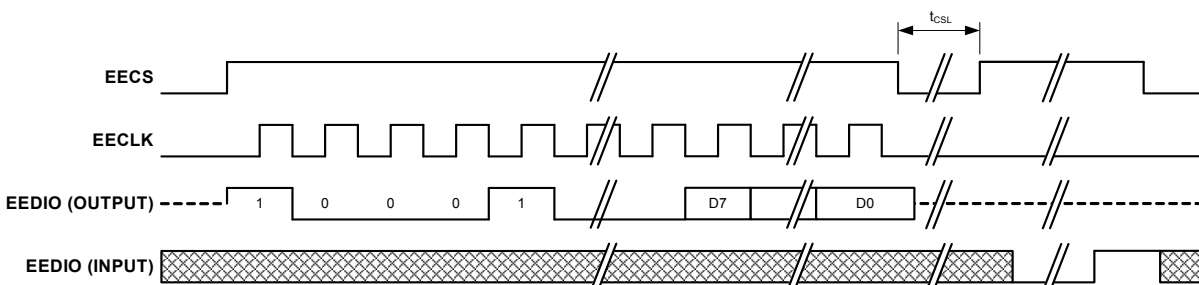

Figure 3.14 EEPROM WRAL Cycle

Table 3.4, "Required EECLK Cycles", shown below, shows the number of EECLK cycles required for each EEPROM operation.

Table 3.4 Required EECLK Cycles

OPERATION	REQUIRED EECLK CYCLES
ERASE	10
ERAL	10
EWDS	10
EWEN	10
READ	18
WRITE	18
WRAL	18

3.3.5.3.2 HOST INITIATED MAC ADDRESS, SSID, SSVID RELOAD

The Host can initiate a reload of the MAC address, SSID, and SSVID from the EEPROM by issuing the RELOAD command via the E2P command (E2P_CMD) register. If the first byte read from the EEPROM is not A5h, it is assumed that the EEPROM is not present, or not programmed, and the RELOAD operation will fail. The "EEPROM Loaded" bit indicates a successful reload of the MAC address, SSID, and SSVID.

3.3.5.3.3 EEPROM COMMAND AND DATA REGISTERS

Refer to [Section 4.2.11, "EEPROM Command Register \(E2P_CMD\)," on page 100](#) and [Section 4.2.12, "EEPROM Data Register \(E2P_DATA\)," on page 103](#) for a detailed description of these registers. Supported EEPROM operations are described in these sections.

3.3.5.3.4 EEPROM TIMING

Refer to [Section 5.8, "EEPROM Timing," on page 166](#) for detailed EEPROM timing specifications.

3.3.6 System Control and Status Registers (SCSR)

Please refer to [Section 4.2, "System Control and Status Registers \(SCSR\)," on page 87](#) for a complete description of the SCSR.

3.4 DMA Controller (DMAC)

The DMA Controller is designed to transfer data from and to the MAC RX and TX Data paths. Similar to the MAC, it contains separate TX and RX data paths that are controlled by a single arbiter.

The DMA Controller includes the following features:

- Generic 32-bit DMA with single-channel Transmit and Receive engines
- Optimized for packet-oriented DMA transfers with frame delimiters
- Supports dual-buffer and linked-list Descriptor Chaining
- Descriptor architecture allows large blocks of data transfer with minimum Host intervention - each descriptor can transfer up to 2KB of data
- Comprehensive status reporting for normal operation and transfers with errors
- Supports programmable interrupt options for different operational conditions
- Supports Start/Stop modes of operation
- Selectable round-robin or fixed priority arbitration between Receive and Transmit engines

The DMA controller consists of independent transmit (TX) and receive (RX) engines and a control and status register space (DCSR). The transmit engine transfers data from Host memory through the PCI Bridge (PCIB) to the MAC, while the receive engine transfers data from the MAC, through the PCIB to Host memory. The DMAC utilizes descriptors to efficiently move data from source to destination with minimal Host intervention. Descriptors are 4-DWORD (16-byte) aligned data structures in Host memory that inform the DMAC of the location of data buffers in Host memory and also provide a mechanism for communicating status to the Host on completion of DMA transactions. The DMAC has been designed for packet-oriented data transfer, such as frames in Ethernet. The DMAC can be programmed to assert an interrupt for situations such as frame transmit or receive transfer completed, and other normal, as well as error conditions that are described in the DMAC Control and Status Registers (DCSR) section.

Note: Descriptors should not cross cache line boundaries if cache memory is used.

3.4.1 DMA Controller Architecture

The DMA Controller has four main hardware components: TX DMA engine, RX DMA engine, the DMA arbiter, and the DCSR.

- TX DMA Engine - The transmit DMA engine fetches transmit descriptors from Host memory and handles data transfers from Host memory to the MAC destination port.
- RX DMA Engine - The receive DMA engine fetches receive descriptors from Host memory and handles data transfers from the MAC source port to destination buffers in Host memory.
- DMA Arbiter - The DMA arbiter controls access to Host memory. It can be configured to support round robin or fixed priority arbitration.
- DCSR - The DMA control and status register block implements register bits that control and monitor the operation of the DMA subsystem.

3.4.2 Data Descriptors and Buffers

The DMAC and the driver communicate through two data structures:

- DMA Control and Status Registers (DCSR), as described in [Section 4.3, "DMAC Control and Status Registers \(DCSR\)," on page 104](#).
- Descriptor lists and data buffers, described in this chapter.

The DMAC transfers RX data frames to the RX buffers in Host memory and transmits data from TX buffers in the Host memory. Descriptors that reside in Host memory contain pointers to these buffers.

There are two DMA descriptor lists; one for receive operations and one for transmit operations. The base address of each list is written into the RX_BASE_ADDR and TX_BASE_ADDR registers, respectively. A descriptor list is forward linked (either implicitly or explicitly). Descriptors are usually placed in the physical memory in an incrementing and a contiguous addressing scheme. However, the last descriptor may point back to the first entry to create a ring structure. Explicit chaining of descriptors is accomplished by setting the Second Address Chained flag in both receive and transmit descriptors (RCH - RDES1[24] and TCH - TDES1[24]). Each descriptor's list resides in Host memory. Each descriptor can point to a maximum of two buffers. This enables the use of two physically addressed, as well as non-contiguous memory buffers.

Data buffers reside in the Host memory space. An Ethernet frame can be fragmented across multiple data buffers, but a data buffer cannot contain more than one Ethernet frame. Data chaining refers to Ethernet frames that span multiple data buffers. Data buffers contain only data used in the Ethernet frame. The buffer status is maintained in the descriptor. In a ring structure, each descriptor can point to up to two data buffers with the restriction that both buffers contain data for the same Ethernet frame. In a chain structure, each descriptor points to a single data buffer and to the next descriptor in the chain.

The DMAC will skip to the next frame buffer when end of frame is detected. Data chaining can be enabled or disabled. The ring and chain type descriptor structures are illustrated in [Figure 3.15](#).

Note: Descriptors of zero buffer length are not supported at the initial and final descriptors of a chain.

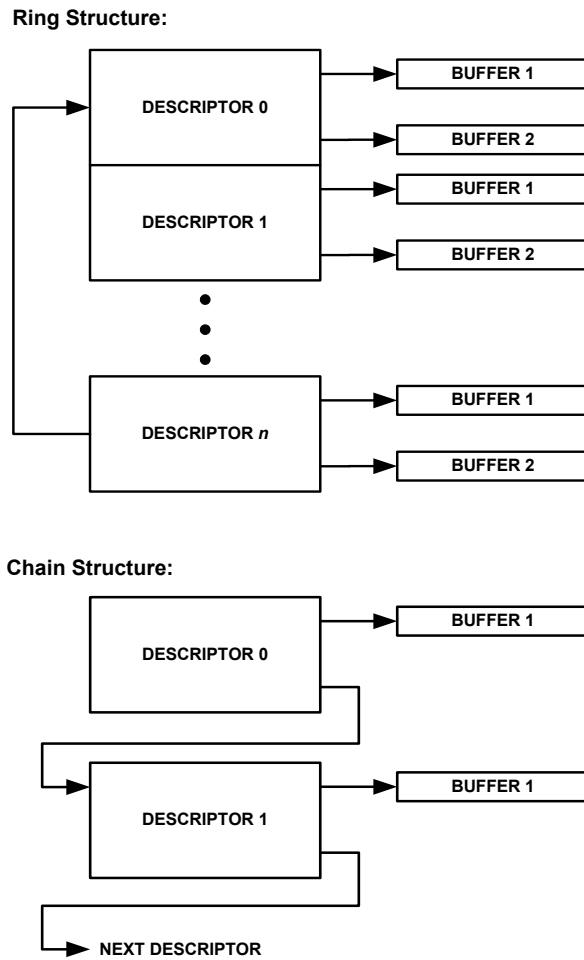

Figure 3.15 Ring and Chain Descriptor Structures

Datasheet

3.4.2.1 Receive Descriptors

The receive descriptors must be 4-DWORD (16-byte) aligned. Except for the case where descriptor address chaining is disabled (RCH=0), there are no alignment restrictions on receive buffer addresses. Providing two buffers, two byte-count buffers, and two address pointers in each descriptor facilitates compatibility with various types of memory-management schemes. Figure 3.16 shows the receive descriptor.

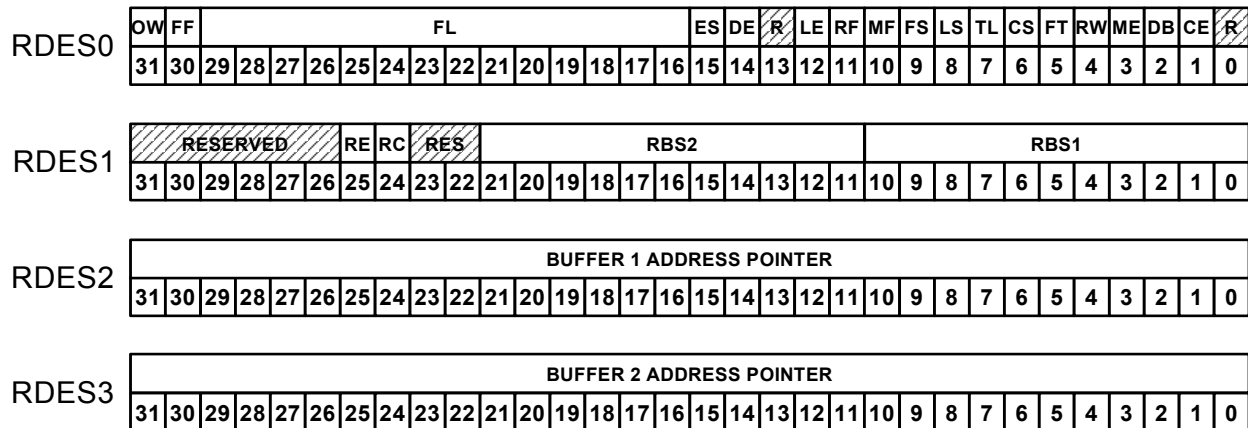

Figure 3.16 Receive Descriptor

Receive Descriptor 0 (RDES0)

RDES0 contains the received frame status, the frame length, and the descriptor ownership information.

Table 3.5 RDES0 Bit Fields

BITS	DESCRIPTION
31	<p>OWN - Own Bit When set, indicates that the descriptor block and associated buffer(s) are owned by the DMA controller. When reset, indicates that the descriptor block and associated buffer(s) are owned by the Host system.</p> <p>Host Actions: Checks this bit to determine ownership of the descriptor block and associated buffer(s). The Host sets this bit to pass ownership to the DMAC. The Host does not modify a descriptor block or access its associated buffer(s) until this bit is cleared by DMAC or until the DMAC is in STOPPED state, whichever comes first.</p> <p>DMAC Actions: Reads this bit to determine ownership of the descriptor block and its associated buffer(s). The DMAC clears this bit either when it completes the frame reception or when the buffers that are associated with this descriptor are full. By clearing this bit, the DMAC closes the descriptor block and passes ownership to the Host. If the DMAC fetches a descriptor with the OWN bit cleared, the DMAC state machine enters the SUSPENDED state.</p>
30	<p>FF - Filter Fail Indicates that the current frame failed the receive address filtering. This bit can only be set when receive all (RXALL) is set in the MAC control register (MAC_CR). This bit is only valid when the last descriptor (LS) bit is set and the received frame is greater than or equal to 64 bytes in length.</p> <p>Host Actions: Checks this bit to determine status.</p> <p>DMAC Actions: Sets/clears this bit to define status.</p>

Table 3.5 RDES0 Bit Fields (continued)

BITS	DESCRIPTION
29:16	<p>FL - Frame Length Indicates the length in bytes, including the CRC, of the received frame that was transferred to Host memory. This field is set only after the last descriptor (LS) bit is set and the descriptor error (DE) is reset.</p> <p>Host Actions: Reads this field to determine Frame Length. DMAC Actions: Initializes this field to define Frame Length.</p>
15	<p>ES - Error Summary Indicates the logical OR of the following RDES0 bits: RDES0[1] - CRC error RDES0[6] - Collision seen RDES0[7] - Frame too long RDES0[11] - Runt frame RDES0[14] - Descriptor Error</p> <p>Host Actions: Checks this bit to determine status. DMAC Actions: Sets/clears this bit to define status.</p>
14	<p>DE - Descriptor Error When set, indicates a frame truncation caused by a frame that does not fit within the current descriptor buffers, and that the DMA controller does not own the next descriptor. The frame is truncated. This field is set only after the last descriptor (LS) bit is set.</p> <p>Host Actions: Checks this bit to determine status. DMAC Actions: Sets/clears this bit to define status.</p>
13	<p>RESERVED</p> <p>Host Actions: Cleared on writes and ignored on reads. DMAC Actions: Ignored on reads and cleared on writes.</p>
12	<p>LE - Length Error When set, this bit indicates that the actual length does not match with the Length/Type field of the incoming frame.</p> <p>Host Actions: Checks this bit to determine status. DMAC Actions: Sets/clears this bit to define status.</p>
11	<p>RF - Runt Frame When set, this bit indicates that frame was prematurely terminated before the collision window (64 bytes). Runt frames are passed on to the Host memory only if the Pass Bad Frames bit (PASS_BAD) in the MAC control register (MAC_CR) is set.</p> <p>Host Actions: Checks this bit to determine status. DMAC Actions: Sets/clears this bit to define status.</p>
10	<p>MF - Multicast Frame When set, this bit indicates that the received frame has a Multicast address.</p> <p>Host Actions: Checks this bit to determine status. DMAC Actions: Sets/clears this bit to define status.</p>
9	<p>FS - First Descriptor When set, indicates that this descriptor contains the first buffer of a frame. If the size of the first buffer is 0, the second buffer contains the beginning of the frame. If the size of the second buffer is also 0, the second descriptor contains the beginning of the frame.</p> <p>Host Actions: Checks this bit to determine status. DMAC Actions: Sets/clears this bit to define status.</p>
8	<p>LS - Last Descriptor When set, indicates that the buffers pointed to by this descriptor are the last buffers of the frame.</p> <p>Host Actions: Checks this bit to determine status. DMAC Actions: Sets/clears this bit to define status.</p>

Table 3.5 RDES0 Bit Fields (continued)

BITS	DESCRIPTION
7	<p>TL - Frame Too Long When set, indicates the frame length exceeds maximum Ethernet-specified size of 1518 bytes (or 1522 bytes when VLAN tagging is enabled). This bit is valid only when last descriptor (LS) is set. Frame too long is only a frame length indication and does not cause any frame truncation.</p> <p>Host Actions: Checks this bit to determine status. DMAC Actions: Sets/clears this bit to define status.</p>
6	<p>CS - Collision Seen When set, this bit indicates that the frame has seen a collision after the collision window. This indicates that a late collision has occurred.</p> <p>Host Actions: Checks this bit to determine status. DMAC Actions: Sets/clears this bit to define status.</p>
5	<p>FT - Frame Type When set, indicates that the frame is an Ethernet-type frame (frame length field is greater than or equal to 1536 bytes). When clear, indicates that the frame is an IEEE 802.3 frame. This bit is not valid for runt frames of less than 14 bytes.</p> <p>Host Actions: Checks this bit to determine status. DMAC Actions: Sets/clears this bit to define status.</p>
4	<p>RW – Receive Watchdog When set, indicates that the receive watchdog timer expired while receiving the current packet with length greater than 2048 bytes through 2560 bytes.</p> <p>Host Actions: Checks this bit to determine status. DMAC Actions: Sets/clears this bit to define status.</p>
3	<p>ME - MII Error When set, this bit indicates that a receive error was detected during frame reception (RX_ER asserted on internal MII bus).</p> <p>Host Actions: Checks this bit to determine status. DMAC Actions: Sets/clears this bit to define status.</p>
2	<p>DB - Dribbling Bit When set, indicates that the frame contained a noninteger multiple of 8 bits. This error is reported only if the number of dribbling bits in the last byte is 4 in MII operating mode, or at least 3 in 10 Mb/s serial operating mode. This bit is not valid if collision seen (CS - RDES0[6]) is set. If set, and the CRC error (CE - RDES0[1]) is reset, then the packet is valid.</p> <p>Host Actions: Checks this bit to determine status. DMAC Actions: Sets/clears this bit to define status.</p>
1	<p>CE - CRC Error When set, indicates that a cyclic redundancy check (CRC) error occurred on the received frame. This bit is also set when the MII error signal is asserted during the reception of a receive packet even though the CRC may be correct. This bit is not valid if one of the following conditions exist:</p> <ul style="list-style-type: none"> ■ The received frame is a runt frame ■ A collision occurred while the packet was being received ■ A watchdog timeout occurred while the packet was being received <p>Host Actions: Checks this bit to determine status. DMAC Actions: Sets/clears this bit to define status.</p>
0	<p>RESERVED</p> <p>Host Actions: Cleared on writes and ignored on reads. DMAC Actions: Ignored on reads and cleared on writes.</p>

Receive Descriptor 1 (RDES1)

Table 3.6 RDES1 Bit Fields

BITS	DESCRIPTION
31:26	RESERVED <i>Host Actions:</i> Cleared on writes and ignored on reads. <i>DMAC Actions:</i> Ignored on reads. DMAC does not write to RDES1.
25	RER - Receive End of Ring When set, indicates that the DMAC reached the final descriptor. Upon servicing this descriptor, the DMAC returns to the base address of the DMA descriptor list pointed to by the Receive List Base Address Register (RX_BASE_ADDR) . <i>Host Actions:</i> Initializes this bit. <i>DMAC Actions:</i> Reads this bit to determine if this is the final descriptor in the ring.
24	RCH - Second Address Chained When set, indicates that the second address in the descriptor is the next descriptor address, rather than the second buffer address. When RCH is set, RBS2 (RDES1[21:11]) must be all zeros. RCH is ignored if RER (RDES1[25]) is set. <i>Host Actions:</i> Initializes this bit. <i>DMAC Actions:</i> Reads this bit to determine if second address is next descriptor address.
23:22	RESERVED <i>Host Actions:</i> Cleared on writes and ignored on reads. <i>DMAC Actions:</i> Ignored on reads. DMAC does not write to RDES1.
21:11	RBS2 - Receive Buffer 2 Size Indicates the size, in bytes, of the second data buffer. The buffer size must be a multiple of 4. This field is not valid if RCH (RDES1[24]) is set. <i>Host Actions:</i> Initializes this field. <i>DMAC Actions:</i> Reads this field to determine the allocated size of associated data buffer.
10:0	RBS1 - Receive Buffer 1 Size Indicates the size, in bytes, of the first data buffer. The buffer size must be a multiple of 4. In the case the buffer size is not a multiple of 4, the resulting behavior is undefined. If this field is 0, the DMA controller ignores this buffer and uses buffer2. (This field cannot be zero if the descriptor chaining is used – Second Address Chained (RCH - RDES1[24]) is set). <i>Host Actions:</i> Initializes this field. <i>DMAC Actions:</i> Reads this field to determine the allocated size of associated data buffer.

Receive Descriptor 2 (RDES2)

Table 3.7 RDES2 Bit Fields

BITS	DESCRIPTION
31:0	Buffer 1 Address Pointer Indicates the address of buffer 1 in the Host memory. There are no limitations on the buffer address alignment. <i>Host Actions:</i> Initializes this field. <i>DMAC Actions:</i> Reads this field upon opening a new DMA descriptor to obtain the buffer address.

Receive Descriptor 3 (RDES3)

Table 3.8 RDES3 Bit Fields

BITS	DESCRIPTION
31:0	<p>Buffer 2 Address Pointer (Next Descriptor Address) The RCH (Second Address Chained) bit (RDES1[24]) determines the usage of this field as follows:</p> <p>RCH is zero: This field contains the pointer to the address of buffer 2 in Host memory. The buffer must be DWORD (32-bit) aligned (RDES3[1:0] = 00b). In the case where the buffer is not DWORD aligned, the resulting behavior is undefined.</p> <p>RCH is one: Descriptor chaining is in use and this field contains the pointer to the next descriptor in Host memory. The descriptor must be 4-DWORD (16-byte) aligned (RDES3[3:0] = 0000b). In the case where the buffer is not 4-DWORD aligned, the resulting behavior is undefined.</p> <p>Note: If RER (RDES1[25]) is set, RCH is ignored and this field is treated as a pointer to buffer 2 as in the “RCH is zero” case above.</p> <p>Host Actions: Initializes this field. DMAC Actions: Reads this field upon opening a new DMA descriptor to obtain the buffer address.</p>

3.4.2.2 Transmit descriptors

The descriptors must be 4-DWORD (16-byte) aligned, while there are no alignment restrictions on transmit buffer addresses. Providing two buffers, two byte-count buffers, and two address pointers in each descriptor facilitates compatibility with various types of memory-management schemes. Figure 3.17 shows the Transmit Descriptor format.

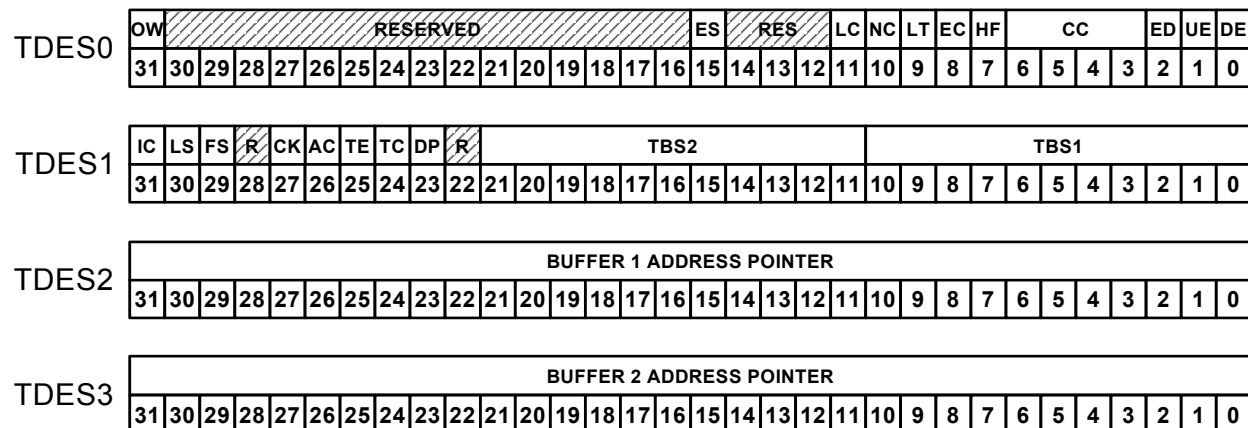

Figure 3.17 Transmit Descriptor

Transmit Descriptor 0 (TDES0)

TDES0 contains the transmitted frame status and the descriptor ownership information.

Table 3.9 TDES0 Bit Fields

BITS	DESCRIPTION
31	<p>OWN - Own Bit When set, indicates that the descriptor block and associated buffer(s) are owned by the DMA controller. When reset, indicates that the descriptor block and associated buffer(s) are owned by the Host system.</p> <p>Host Actions: Checks this bit to determine ownership of the descriptor block and associated buffer(s). The Host sets this bit to pass ownership to the DMAC. The Host does not modify a descriptor block or access its associated buffer(s) until this bit is cleared by DMAC or until the DMAC is in STOPPED state, whichever comes first. The ownership bit of the first descriptor of the frame should be set after all subsequent descriptors belonging to the same frame have been set. This avoids a possible race condition between the DMA controller fetching a descriptor and the Host setting an ownership bit.</p> <p>DMAC Actions: Reads this bit to determine ownership of the descriptor block and its associated buffer(s). The DMAC clears this bit either when it completes the frame transmission or when the buffers that are associated with this descriptor are empty. By clearing this bit, the DMAC closes the descriptor block and passes ownership to the Host. If the DMAC fetches a descriptor with the OWN bit cleared, the DMAC state machine enters the SUSPENDED state.</p>
30:16	<p>RESERVED</p> <p>Host Actions: Cleared on writes and ignored on reads. DMAC Actions: Ignored on reads and cleared on writes.</p>
15	<p>ES - Error Summary Indicates the logical OR of the following TDES0 bits: TDES0[2] – Excessive Deferral TDES0[8] – Excessive collisions TDES0[9] – Late collision TDES0[10] – No carrier TDES0[11] – Loss of carrier</p> <p>Host Actions: Checks this bit to determine status. DMAC Actions: Sets/clears this bit to define status.</p>
14:12	<p>RESERVED</p> <p>Host Actions: Cleared on writes and ignored on reads. DMAC Actions: Ignored on reads and cleared on writes.</p>
11	<p>LC - Loss of Carrier When set, indicates loss of carrier during transmission.</p> <p>Host Actions: Checks this bit to determine status. DMAC Actions: Sets/clears this bit to define status.</p>
10	<p>NC - No Carrier When set, indicates that the carrier signal from the transceiver was not present during transmission.</p> <p>Host Actions: Checks this bit to determine status. DMAC Actions: Sets/clears this bit to define status.</p>
9	<p>LT - Late Collision When set, indicates that the frame transmission was aborted due to collision occurring after the collision window of 64 bytes.</p> <p>Host Actions: Checks this bit to determine status. DMAC Actions: Sets/clears this bit to define status.</p>

Table 3.9 TDES0 Bit Fields (continued)

BITS	DESCRIPTION
8	<p>EC - Excessive Collision When set, indicates that the transmission was aborted after 16 successive collisions while attempting to transmit the current frame.</p> <p>Host Actions: Checks this bit to determine status. DMAC Actions: Sets/clears this bit to define status.</p>
7	<p>RESERVED</p> <p>Host Actions: Cleared on writes and ignored on reads. DMAC Actions: Ignored on reads and cleared on writes.</p>
6:3	<p>CC - Collision Count This 4-bit counter indicates the number of collisions that occurred before the frame was transmitted. Not valid when the excessive collisions bit (EC - TDES0[8]) is also set.</p> <p>Host Actions: Reads this field to determine Collision Count. DMAC Actions: Initializes this field to define Collision Count.</p>
2	<p>ED - Excessive Deferral If the deferred bit is set in the control register, the setting of the Excessive Deferral bit indicates that the transmission has ended because of deferral of over 24,288-bit times during transmission.</p> <p>Host Actions: Checks this bit to determine status. DMAC Actions: Sets/clears this bit to define status.</p>
1	<p>Reserved</p>
0	<p>DE - Deferred When set, indicates that the DMA Controller had to defer while ready to transmit a frame because the carrier was asserted.</p> <p>Host Actions: Checks this bit to determine status. DMAC Actions: Sets/clears this bit to define status.</p>

Transmit Descriptor 1 (TDES1)

Table 3.10 TDES1 Bit Fields

BITS	DESCRIPTION
31	<p>IC - Interrupt on Completion When set, the DMA Controller sets transmit interrupt (TI - DMAC_STATUS[0]) after the present frame has been transmitted. This field is valid only when last segment (LS - TDES1[30]) is set.</p> <p>Host Actions: Initializes this bit. DMAC Actions: Reads this bit to determine whether IOC should be asserted.</p>
30	<p>LS - Last Segment When set, indicates that the buffer contains the last segment of a frame.</p> <p>Host Actions: Initializes this bit. DMAC Actions: Reads this bit to determine whether the buffer contains the last segment of a frame.</p>

Table 3.10 TDES1 Bit Fields (continued)

BITS	DESCRIPTION
29	<p>FS - First Segment When set, indicates that the buffer contains the first segment of a frame.</p> <p><i>Host Actions:</i> Initializes this bit. <i>DMAC Actions:</i> Reads this bit to determine whether the buffer contains the first segment of a frame.</p>
28	<p>RESERVED</p> <p><i>Host Actions:</i> Cleared on writes and ignored on reads. <i>DMAC Actions:</i> Ignored on reads. DMAC does not write to TDES1.</p>
27	<p>CK - TX Checksum Enable if this bit is set in conjunction with the first segment bit (FS) in TDES1 and the TX checksum offload engine enable bit (TX_COE_EN) in the checksum offload engine control register (COE_CR), the TX checksum offload engine (TXCOE) will calculate an L3 checksum for the associated frame. The 16-bit checksum is inserted in the transmitted data as specified in Section 3.5.6, "Transmit Checksum Offload Engine (TXCOE)," on page 63.</p> <p><i>Host Actions:</i> Initializes this bit. <i>DMAC Actions:</i> Reads this bit to determine whether TXCOE should be enabled.</p>
26	<p>AC - Add CRC Disable When set, the DMA Controller does not append the CRC to the end of the transmitted frame. This field is valid only when first segment (FS - TDES1[29]) is set.</p> <p><i>Host Actions:</i> Initializes this bit. <i>DMAC Actions:</i> Reads this bit to determine whether CRC should be appended to the end of the transmitted frame.</p>
25	<p>TER - Transmit End of Ring When set, indicates that the DMAC reached the final descriptor. Upon servicing this descriptor, the DMAC returns to the base address of the DMA descriptor list pointed by the Transmit List Base Address Register (TX_BASE_ADDR).</p> <p><i>Host Actions:</i> Initializes this bit. <i>DMAC Actions:</i> Reads this bit to determine if this is the final descriptor in the ring.</p>
24	<p>TCH - Second Address Chained When set, indicates that the second address in the descriptor is the next descriptor address, rather than the second buffer address. When this bit is set, the TBS2 (TDES1[21:11]) must be all zeros. TCH is ignored if TER (TDES1[25]) is set.</p> <p><i>Host Actions:</i> Initializes this bit. <i>DMAC Actions:</i> Reads this bit to determine if second address is next descriptor address.</p>
23	<p>DPD - Disable Padding When set, the DMA Controller does not automatically add a padding field to a packet shorter than 64 bytes. When cleared, the DMA Controller automatically adds a padding field and also a CRC field to a packet shorter than 64 bytes. The CRC field is added despite the state of the add CRC disable (AC - TDES1[26]) flag. This is valid only when the first segment (FS - TDES1[29]) is set.</p> <p><i>Host Actions:</i> Initializes this bit. <i>DMAC Actions:</i> Reads this bit to determine if padding is enabled.</p>
22	<p>RESERVED</p> <p><i>Host Actions:</i> Cleared on writes and ignored on reads. <i>DMAC Actions:</i> Ignored on reads. DMAC does not write to TDES1.</p>
21:11	<p>TBS2 - Transmit Buffer 2 Size Indicates the size, in bytes, of the second data buffer. This field is not valid if TCH (TDES1[24]) is set.</p> <p><i>Host Actions:</i> Initializes this field. <i>DMAC Actions:</i> Reads this field to determine the allocated size of associated data buffer.</p>

Table 3.10 TDES1 Bit Fields (continued)

BITS	DESCRIPTION
10:0	<p>TBS1 - Transmit Buffer 1 Size Indicates the size, in bytes, of the first data buffer. If this field is 0, the DMA controller ignores this buffer and uses buffer2.</p> <p>Host Actions: Initializes this field. DMAC Actions: Reads this field to determine the allocated size of associated data buffer.</p>

Transmit Descriptor 2 (TDES2)

Table 3.11 TDES2 Bit Fields

BITS	DESCRIPTION
31:0	<p>Buffer 1 Address Pointer This is the physical address of buffer 1. There are no limitations on the buffer address alignment.</p> <p>Host Actions: Initializes this field. DMAC Actions: Reads this field upon opening a new DMA descriptor to obtain the buffer address.</p>

Transmit Descriptor 3 (TDES3)

Table 3.12 TDES3 Bit Fields

BITS	DESCRIPTION
31:0	<p>Buffer 2 Address Pointer (Next Descriptor Address) The TCH (Second Address Chained) bit (TDES1[24]) determines the usage of this field as follows:</p> <p>TCH is zero: This field contains the pointer to the address of buffer 2 in Host memory. There are no limitations on buffer address alignment.</p> <p>TCH is one: Descriptor chaining is in use and this field contains the pointer to the next descriptor in Host memory. The descriptor must be 4-DWORD (16-byte) aligned (TDES3[3:0] = 0000b). In the case where the buffer is not 4-DWORD aligned, the resulting behavior is undefined.</p> <p>Note: If TER (TDES1[25]) is set, TCH is ignored and this field is treated as a pointer to buffer 2 as in the “TCH is zero” case above.</p> <p>Host Actions: Initializes this field. DMAC Actions: Reads this field upon opening a new DMA descriptor to obtain the buffer address.</p>

3.4.3 Initialization

The following sequence explains the initialization steps for the DMA controller and activation of the receive and transmit paths:

1. Configure the BUS_MODE register.
2. Mask unnecessary interrupts by writing to the DMAC_INTR_ENA register.
3. Software driver writes to descriptor base address registers RX_BASE_ADDR and TX_BASE_ADDR after the RX and TX descriptor lists are created.
4. Write DMAC_CONTROL to set bits 13 (ST) and 1 (SR) to start the TX and RX DMA. The TX and RX engines enter the running state and attempt to acquire descriptors from the respective descriptor lists. The receive and transmit engines begin processing receive and transmit operations.
5. Set bit 2 (RXEN) of MAC_CR to turn the receiver on.
6. Set bit 3 (TXEN) of MAC_CR to turn the transmitter on.

Note: The TX and RX processes and paths are independent of each other and can be started or stopped independently of one another. However, the control sequence required to activate the RX path must be followed explicitly. The RX DMAC should be activated before the MAC's receiver. Failure to do so may lead to unpredictable results and untoward operation.

3.4.4 Transmit Operation

Transmission proceeds as follows:

1. The Host system sets up the Transmit Descriptor (TDES0-3) and sets the OWN bit (TDES0[31]).
2. Once set to the running state, the DMA controller reads the Host memory buffer to collect the first descriptor. The starting address of the first descriptor is read from the TX_BASE_ADDR register.
3. Data transfer begins, and continues until the last DWORD of the frame is transferred. A frame may traverse multiple descriptors. Frames must be delimited by the first segment (FS - TDES1[29]) and last segment (LS - TDES1[30]) respectively.
4. When the frame transmission is completed, status is written into TDES0 with the OWN bit reset to 0. If the DMAC detects a descriptor flag that is owned by the Host, or if an error condition occurs, the transmit engine enters into the suspended state and both (TU) Transmit Buffer Unavailable and (NIS) Normal Interrupt Summary bits are set. Transmit Interrupt (TI) is set after completing transmission of a frame that has an interrupt, and on completion the last descriptor (TDES0[30]) is set. A new frame transmission will move the DMA from the Suspended state.

3.4.5 Receive Operation

The general sequence of events for reception of a frame is as follows:

1. The Host system sets up the receive descriptors RDES0-3 and sets the OWN bit (RDES0[31]). The Host system polls the OWN bit and, once it recognizes a descriptor for itself, it can begin working on the descriptor.
2. Once set to the running state, the DMA controller reads the Host memory buffer to collect the first descriptor. The starting address of the first descriptor is read from the RX_BASE_ADDR register.
3. Data transfer begins, and continues until the last DWORD of the frame is transferred. A frame may traverse multiple descriptors. The DMA controller delimits the frames by setting the First Segment (RDES0[9]) and Last Segment (RDES0[8]) respectively. As a buffer is filled, or when the Last Segment is transferred to the Host memory buffer, the descriptor of that buffer is closed (OWN bit is cleared).
4. When a frame transfer is completed, the status field in RDES0 of the last descriptor is updated and the OWN bit reset to 0, and the Receive Interrupt (RI) is then set. The receive engine continues

to fetch the next descriptor and repeat the process unless it encounters a descriptor marked as being owned by the Host system. If this occurs, the Receive Buffer Unavailable bit (RU) is set and the receive engine enters the suspended state. If a new frame arrives while the receive engine is in the suspended state, the DMA controller re-fetches the current descriptor. If the descriptor is now owned by the DMAC, the receive process continues. If the descriptor is still owned by the Host system, the frame is discarded and DMAC re-enters the suspend state. This process is repeated for each received frame.

5. The reception of a new frame will move the RX engine from the suspend state.

Note: Oversized RX packets must not cross from one buffer to another unless either the starting address of the 2nd buffer is DWORD aligned, or the oversized packet is to be discarded.

3.4.6 Receive Descriptor Acquisition

The receive engine always attempts to acquire an extra descriptor in the anticipation of an incoming frame. Descriptor acquisition is attempted if any of the following conditions are satisfied:

- When the (SR) Start/Stop Receive bit (bit 1 of DMAC_CONTROL) sets immediately after being placed in the running state
- When the memory buffer ends before the frame ends for the current transfer
- When the controller completes the reception of a frame and the current receive descriptor has been closed
- When the receive process is suspended because of a Host-owned buffer (RDES0[31]=0) and a new frame is being received
- When receive poll demand is issued

3.4.7 Suspend State Behavior

The following sections detail the suspend state behavior of the transmit and receive engines.

3.4.7.1 Transmit Engine

The Transmit Engine enters the suspended state when either of these conditions occurs:

- The DMA controller detects a descriptor owned by the Host system (TDES0[31]=0). To resume, the driver must give the descriptor ownership to the DMA controller and then issue a poll demand command.
- A DMA transmission was aborted due to a local error.

In both of these cases the abnormal interrupt summary (AIS bit in the DMAC_STATUS register) and the transmit interrupt (TI bit in the DMAC_STATUS register) are set and the appropriate status bit in TDES0 is set. The position in the transmit list is retained. The retained position is that of the descriptor following the descriptor that was last closed.

Note: The DMA controller does not automatically poll the transmit descriptor list. The driver must explicitly issue a transmit poll demand after rectifying the suspension cause.

3.4.7.2 Receive Engine

The Receive Engine enters the suspended state when a receive buffer is unavailable. If a frame arrives when the receiver is in the suspended state, the receive engine re-fetches the descriptor and, if now owned by the DMA controller, reenters the running state and starts frame reception. Receive polling resumes from the last list position. The DMA controller generates a Receive Buffer Unavailable interrupt (RU bit in the DMAC_STATUS register) only once - when entering the suspended state from the running state. In the suspended state, if a new frame is received and a descriptor is still not available, the frame is discarded. Only in the suspended state does the controller respond to a Receive

Poll Demand (for example, a buffer is available before the next incoming frame) and enter the running state.

3.4.8 Stopping Transmission and Reception

The receive and transmit processes and paths are independent of each other. One does not need to be stopped as a result of stopping the other. However, the sequence of operations required to stop elements in the receive path must be explicitly followed, in order to preclude unexpected results and untoward operation.

In order to stop the transmission, the TX DMAC should be stopped before the MAC's transmitter (Clear bit 13 (ST) of DMAC_CONTROL to stop TX DMA, then clear bit 3 (TXEN) of MAC_CR to turn the transmitter off).

In order to stop reception, the MAC's receiver should be stopped prior to stopping the RX DMAC (Clear bit 2 (RXEN) of MAC_CR to turn the receiver off, then clear bit 1 (SR) of DMAC_CONTROL to stop RX DMA). Performing these steps in the reverse order will result in RX DMA not stopping (DMAC_STATUS will continue to show the Receive Process State (RS) as Running and Receive Process Stopped (RPS) does not assert).

3.4.9 TX Buffer Fragmentation Rules

Transmit buffers must adhere to the following rules:

- Each buffer can start and end on any arbitrary byte alignment
- The first buffer of any transmit packet can be any length
- Middle buffers (i.e., those with First Segment = Last Segment = 0) must be greater than, or equal to 4 bytes in length
- The final buffer of any transmit packet can be any length

Additionally, the MIL operates in store-and-forward mode and has specific rules with respect to fragmented packets. The total space consumed in the TX FIFO (MIL) must be limited to no more than 2KB - 3 DWORDs (2,036 bytes total). Any transmit packet that is so highly fragmented that it takes more space than this must be un-fragmented (by copying to a driver-supplied buffer) before the transmit packet can be sent to LAN9420/LAN9420i.

One approach to determine whether a packet is too fragmented is to calculate the actual amount of space that it will consume, and check it against 2,036 bytes. Another approach is to check the number of buffers against a worst-case limit of 86 (see explanation below).

3.4.9.1 Calculating Worst-Case TX FIFO (MIL) Usage

The actual space consumed by a buffer in the MIL TX FIFO consists of any partial DWORD offsets in the first/last DWORD of the buffer, plus all of the whole DWORDs in between. The worst-case overhead for a TX buffer is 6 bytes, which assumes that it started on the high byte of a DWORD and ended on the low byte of a DWORD. A TX packet consisting of 86 such fragments would have an overhead of 516 bytes (6 * 86) which, when added to a 1514-byte max-size transmit packet (1516 bytes, rounded up to the next whole DWORD), would give a total space consumption of 2,032 bytes, leaving 4 bytes to spare; this is the basis for the "86 fragment" rule mentioned above.

3.4.10 DMAC Interrupts

As described in earlier sections, there are numerous events that cause a DMAC interrupt. The DMAC_STATUS register contains all the bits that might cause an interrupt. The DMAC_INTR_ENA register contains an enable bit for each of the events that can cause a DMAC interrupt. The DMAC interrupt to the Interrupt Controller is asserted if any of the enabled interrupt conditions are satisfied. There are two groups of interrupts: normal and abnormal (as outlined in DMAC_STATUS). Interrupts are cleared by writing a logic 1 to the bit. When all the enabled interrupts within a group are cleared,

the corresponding summary bit is cleared. When both the summary bits are cleared, the DMAC interrupt is de-asserted.

Interrupts are not queued and if a second interrupt event occurs before the driver has responded to the first interrupt, no additional interrupts will be generated. For example, Receive Interrupt (RI bit in the DMAC_STATUS register) indicates that one or more frames was transferred to a Host memory buffer. The driver must scan all descriptors, from the last recorded position to the first one owned by the DMA controller.

An interrupt is generated only once for simultaneous, multiple events. The driver must scan the DMAC_STATUS register for the interrupt cause. The interrupt is not generated again, unless a new interrupting event occurs after the driver has cleared the appropriate DMAC_STATUS bit. For example, the controller generates a receive interrupt (RI) and the driver begins reading DMAC_STATUS. Next, a Receive Buffer Unavailable (RU) occurs. The driver clears the receive interrupt. DMA_INTR gets de-asserted for at least one cycle and then asserted again for the RX buffer unavailable interrupt.

3.4.11 DMAC Control and Status Registers (DCSR)

Please refer [Section 4.3, "DMAC Control and Status Registers \(DCSR\)," on page 104](#) to for a complete description of the DCSR.

3.5 10/100 Ethernet MAC

The Ethernet Media Access Controller (MAC) provides the following features:

- Compliant with the IEEE 802.3 and 802.3u specifications
- Supports 10-Mbps and 100-Mbps data transfer rates
- Transmit and receive message data encapsulation
- Framing (frame boundary delimitation, frame synchronization)
- Error detection (physical medium transmission errors)
- Media access management
- Medium allocation (collision detection, except in full-duplex operation)
- Contention resolution (collision handling, except in full-duplex operation)
- Decoding of control frames (PAUSE command) and disabling the transmitter
- Generation of control frames
- Internal MII interface for communication with the embedded PHY
- Supports Virtual Local Area Network (VLAN) operations
- Supports both full- and half-duplex operations
- Support of CSMA/CD Protocol for half-duplex Mode
- Supports flow control for full-duplex operation
- Wake detection logic, which detects Wakeup Frames and Magic Packets
- Collision detection and auto retransmission on collisions in Half-Duplex Mode
- Preamble generation and removal
- Automatic 32-bit CRC generation and checking
- Options to insert PAD/CRC32 on transmit
- Options to set Automatic Pad stripping in Receive packets
- Checksum offload engine for calculation of layer 3 transmit and receive checksum

The MAC block includes a MAC Interface Layer (MIL). The MIL provides a FIFO interface between the DMAC and the MAC. The MIL provides the following features:

- Provides a bridge between the DMA controller and Ethernet MAC
- Separate paths for transmit and receive operations
- Separate 2KB FIFOs (one for Transmit and one for Receive operations)
- Receive: Sends only filtered packets to DMAC
- Transmit: Supports Store and Forward mechanism
- Transmit: Frame data held in MIL FIFO until the MAC retransmits the packets without collision

The MAC incorporates the essential protocol requirements for operating an Ethernet/IEEE 802.3-compliant node and provides an interface between the Host system and the internal Ethernet PHY. The MAC can operate in either 100-Mbps or 10-Mbps mode.

The MAC operates in both half-duplex and full-duplex modes. When operating in half-duplex mode, the MAC complies fully with Section 4 of ISO/IEC 8802-3 (ANSI/IEEE standard) and ANSI/IEEE 802.3 standards. When operating in full-duplex mode, the MAC complies with IEEE 802.3x full-duplex operation standard.

The MAC provides programmable enhanced features designed to minimize Host supervision, bus utilization, and pre- or post-message processing. These features include the ability to disable retries after a collision, dynamic FCS (Frame Check Sequence) generation on a frame-by-frame basis, automatic pad field insertion and deletion to enforce minimum frame size attributes, and automatic retransmission and detection of collision frames, as well as an L3 checksum offload engine for transmit and receive operations.

The MAC can sustain transmission or reception of minimally-sized back-to-back packets at full line speed with an inter-packet gap (IPG) of 9.6 microseconds for 10 Mbps and 0.96 microseconds for 100 Mbps.

The transmit and receive data paths are separate within the MAC, allowing the highest performance, especially in full duplex mode.

The MAC includes a control and status register block (MCSR) through which the MAC can be configured and monitored by the Host. The MCSR are accessible from the Host system via the Target Interface of the PCIB.

On the backend, the MAC interfaces with the 10/100 PHY through an MII (Media Independent Interface) port which is internal to LAN9420/LAN9420i. The MCSR also provide a mechanism for accessing the PHY's internal registers through the internal SMI (Serial Management Interface) bus.

3.5.1 Flow Control

The MAC supports full-duplex flow control using the pause operation and control frame.

3.5.1.1 Full-Duplex Flow Control

The pause operation inhibits data transmission of data frames for a specified period of time. A pause operation consists of a frame containing the globally assigned multicast address (01-80-C2-00-00-01), the PAUSE opcode, and a parameter indicating the quantum of slot time (512 bit times) to inhibit data transmissions. The PAUSE parameter may range from 0 to 65,535 slot times. The Ethernet MAC logic, on receiving a frame with the reserved multicast address and PAUSE opcode, inhibits data frame transmissions for the length of time indicated. If a pause request is received while a transmission is in progress, then the pause will take effect after the transmission is complete. Control frames are received and processed by the MAC and are passed on.

The MAC also transmits control frames (pause command) under software control. The software driver requests the MAC to transmit a control frame, and gives the value of the PAUSE time to be used in the control frame, through the MAC's FLOW register. The MAC constructs a control frame with the

appropriate values set in all the different fields (as defined in the 802.3x specification) and transmits the frame (via the PHY). The transmission of the control frame is not affected by the current state of the Pause timer value that is set because of a recently received control frame. Refer to [Section 4.4.8, "Flow Control Register \(FLOW\)," on page 130](#) for more information on enabling flow control in the MAC.

3.5.2 Virtual Local Area Network (VLAN) Support

Virtual Local Area Networks or VLANs, as defined within the IEEE 802.3 standard, provide network administrators one means of grouping nodes within a larger network into broadcast domains. To implement a VLAN, four extra bytes are added to the basic Ethernet packet. As shown in [Figure 3.18 VLAN Frame on page 55](#), the four bytes are inserted after the Source Address Field and before the Type/Length field. The first two bytes of the VLAN tag identify the tag, and by convention are set to the value 8100h. The last two bytes identify the specific VLAN associated with the packet; they also provide a priority field.

The MAC supports VLAN-tagged packets. The MAC provides two registers which are used to identify VLAN-tagged packets. One register should normally be set to the conventional VLAN ID of 8100h. The other register provides a way of identifying VLAN frames tagged with a proprietary (not 8100h) identifier. If a packet arrives bearing either of these tags in the two bytes succeeding the Source Address field, the controller will recognize the packet as a VLAN-tagged packet. In this case, the controller increases the maximum allowed packet size from 1518 to 1522 bytes (normally the controller filters packets larger than 1518 bytes). This allows the packet to be received, and then processed by the application, or to be transmitted on the network.

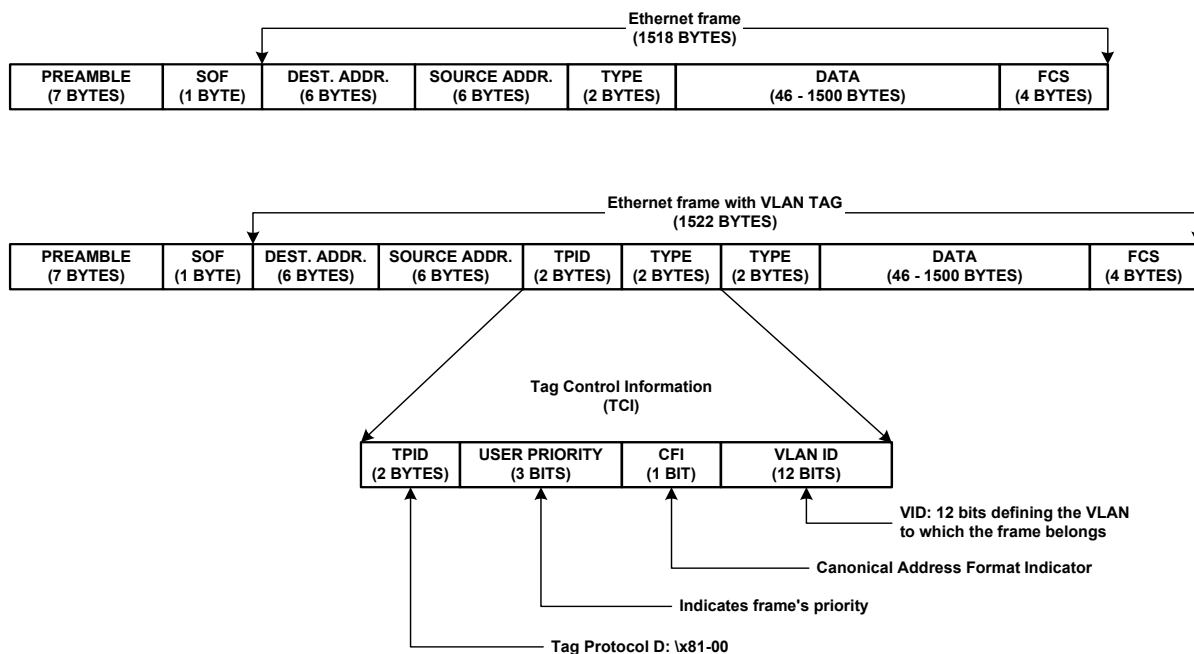

Figure 3.18 VLAN Frame

3.5.3 Address Filtering Functional Description

The Ethernet address fields of an Ethernet packet, consists of two 6-byte fields: one for the destination address and one for the source address. The first bit of the destination address signifies whether it is a physical address or a multicast address.

The address check logic filters the frame based on the Ethernet receive filter mode that has been enabled. Filter modes are specified based on the state of the control bits in [Table 3.13, "Address Filtering Modes"](#), which shows the various filtering modes used by the MAC. These bits are defined in more detail in [Section 4.4.1, "MAC Control Register \(MAC_CR\)," on page 120](#).

If the frame fails the filter, the MAC does not receive the packet. The Host has the option of accepting or ignoring the packet.

Table 3.13 Address Filtering Modes

MCPAS	PRMS	INVFILT	HFILT	HPFILT	DESCRIPTION
0	0	0	0	0	MAC address perfect filtering only for all addresses.
0	0	0	0	1	MAC address perfect filtering for physical address and hash filtering for multicast addresses
0	0	0	1	1	Hash Filtering for physical and multicast addresses
0	0	1	0	0	Inverse Filtering
X	1	0	X	X	Promiscuous
1	0	0	0	X	Pass all multicast frames. Frames with physical addresses are perfect-filtered
1	0	0	1	1	Pass all multicast frames. Frames with physical addresses are hash-filtered

3.5.3.1 Perfect Filtering

This filtering mode passes only incoming frames whose destination address field exactly matches the value programmed into the MAC address high register (refer to [Section 4.4.2, "MAC Address High Register \(ADDRH\)," on page 124](#)) and the MAC address low register (refer to [Section 4.4.3, "MAC Address Low Register \(ADDRL\)," on page 125](#)). The MAC address is formed by the concatenation of the above two registers in the MCSR.

3.5.3.2 Hash Only Filtering Mode

This type of filtering checks for incoming receive packets with either multicast or physical destination addresses, and executes an imperfect address filtering against the hash table.

During imperfect hash filtering, the destination address in the incoming frame is passed through the CRC logic and the upper six bits of the CRC register are used to index the contents of the hash table. The hash table is formed by concatenating the register's multicast hash table high (refer to [Section 4.4.4, "Multicast Hash Table High Register \(HASHH\)," on page 126](#)) and multicast hash table low (refer to [Section 4.4.5, "Multicast Hash Table Low Register \(HASHL\)," on page 127](#)) in the MCSR to form a 64-bit hash table. The most significant bit of the CRC determines the register to be used (High/Low), while the other five bits determine the bit within the register. A value of 00000 selects Bit 0 of the

multicast hash table low register and a value of 11111 selects Bit 31 of the multicast hash table high register.

3.5.3.3 Hash Perfect Filtering

In hash perfect filtering, if the received frame is a physical address, the packet filter block perfect-filters the incoming frame's destination field with the value programmed into the MAC Address High register (refer to [Section 4.4.2, "MAC Address High Register \(ADDRH\)," on page 124](#)) and the MAC address low register (refer to [Section 4.4.3, "MAC Address Low Register \(ADDRL\)," on page 125](#)). If the incoming frame is a multicast frame, however, the packet filter function performs an imperfect address filtering against the hash table.

The imperfect filtering against the hash table is the same imperfect filtering process described in [Section 3.5.3.2](#).

3.5.3.4 Inverse Filtering

During inverse filtering, the packet filter block accepts incoming frames with a destination address not matching the perfect address (i.e., the value programmed into the MAC Address High register and the MAC Address Low register in the CRC block) and rejects frames with destination addresses matching the perfect address.

For all filtering modes, when MCPAS is set, all multicast frames are accepted. When the PRMS bit is set, all frames are accepted regardless of their destination address. This includes all broadcast frames as well.

3.5.4 Wakeup Frame Detection

Setting the Wakeup Frame Enable bit (WAKE_EN) in the "WUCSR—Wakeup Control and Status Register", places the MAC in the wakeup frame detection mode. In this mode, normal data reception is disabled, and detection logic within the MAC examines receive data for the pre-programmed wakeup frame patterns. Upon detection of a wake event, the MAC will assert the wake event interrupt to the Interrupt Controller. In turn, the Interrupt Controller can be programmed to assert its interrupt (IRQ) to the PCIB. In reduced power modes, the IRQ interrupt can be used to generate a wakeup event using the nPME signal, which, if enabled to do so, will return the system to its normal operational state (S0 state). The IRQ interrupt can also be used to generate an interrupt to the Host, via the nINT signal. Upon detection, the Wakeup Frame Received bit (WUFR) in the WUCSR is set. When the Host system clears the WUEN bit, the MAC will resume normal receive operation.

Before putting the MAC into the wakeup frame detection state, the Host application must provide the detection logic with a list of sample frames and their corresponding byte masks. This information is written into the Wakeup Frame Filter register (WUFF). Please refer to [Section 4.4.11, "Wakeup Frame Filter \(WUFF\)," on page 133](#) for additional information on this register.

The MAC supports four programmable filters that support many different receive packet patterns. If remote wakeup mode is enabled, the remote wakeup function receives all frames addressed to the MAC. It then checks each frame against the enabled filter and recognizes the frame as a remote wakeup frame if it passes the wakeup frame filter register's address filtering and CRC value match.

In order to determine which bytes of the frames should be checked by the CRC module, the MAC uses a programmable byte mask and a programmable pattern offset for each of the four supported filters.

The pattern's offset defines the location of the first byte that should be checked in the frame. The byte mask is a 31-bit field that specifies whether or not each of the 31 contiguous bytes within the frame, beginning in the pattern offset, should be checked. If bit *j* in the byte mask is set, the detection logic checks byte offset + *j* in the frame.

In order to load the Wakeup Frame Filter register, the LAN driver software must perform eight writes to the Wakeup Frame Filter register (WUFF). [Table 3.14](#) shows the Wakeup Frame Filter register's structure.

Note 3.1 Wakeup frame detection can be performed when LAN9420/LAN9420i is in any power state. Wakeup frame detection is enabled when the WUEN bit is set.

Note: When wake-up frame detection is enabled via the WUEN bit of the [Wakeup Control and Status Register \(WUCSR\)](#), a broadcast wake-up frame will wake-up the device despite the state of the Disable Broadcast (BCAST) bit in the [MAC Control Register \(MAC_CR\)](#).

Table 3.14 Wakeup Frame Filter Register Structure

Filter 0 Byte Mask							
Filter 1 Byte Mask							
Filter 2 Byte Mask							
Filter 3 Byte Mask							
Reserved	Filter 3 Command	Reserved	Filter 2 Command	Reserved	Filter 1 Command	Reserved	Filter 0 Command
Filter 3 Offset		Filter 2 Offset		Filter 1 Offset		Filter 0 Offset	
Filter 1 CRC-16				Filter 0 CRC-16			
Filter 3 CRC-16				Filter 2 CRC-16			

The Filter *i* Byte Mask defines which incoming frame bytes Filter *i* will examine to determine whether or not this is a wakeup frame. [Table 3.15](#), describes the byte mask's bit fields.

Table 3.15 Filter *i* Byte Mask Bit Definitions

FILTER <i>i</i> BYTE MASK DESCRIPTION	
BITS	DESCRIPTION
31	RESERVED
30:0	Byte Mask: If bit <i>j</i> of the byte mask is set, the CRC machine processes byte <i>pattern-offset + j</i> of the incoming frame. Otherwise, byte <i>pattern-offset + j</i> is ignored.

The Filter *i* command register controls Filter *i* operation. [Table 3.16](#) shows the Filter *i* command register.

Table 3.16 Filter *i* Command Bit Definitions

FILTER <i>i</i> COMMANDS	
BITS	DESCRIPTION
3	Address Type: Defines the destination address type of the pattern. When bit is set, the pattern applies only to multicast frames. When bit is cleared, the pattern applies only to unicast frames.
2:1	RESERVED
0	Enable Filter: When bit is set, Filter <i>i</i> is enabled, otherwise, Filter <i>i</i> is disabled.

The Filter *i* Offset register defines the offset in the frame's destination address field from which the frames are examined by Filter *i*. [Table 3.17](#) describes the Filter *i* Offset bit fields.

Table 3.17 Filter i Offset Bit Definitions

FILTER i OFFSET DESCRIPTION	
BITS	DESCRIPTION
7:0	Pattern Offset: The offset of the first byte in the frame on which CRC is checked for wakeup frame recognition. The MAC checks the first offset byte of the frame for CRC and checks to determine whether the frame is a wakeup frame. Offset 0 is the first byte of the incoming frame's destination address.

The Filter i CRC-16 register contains the CRC-16 result of the frame that should pass Filter i.

Table 3.18 describes the Filter i CRC-16 bit fields.

Table 3.18 Filter i CRC-16 Bit Definitions

FILTER i CRC-16 DESCRIPTION	
BITS	DESCRIPTION
15:0	Pattern CRC-16: This field contains the 16-bit CRC value from the pattern and the byte mask programmed to the wakeup filter register function. This value is compared against the CRC calculated on the incoming frame, and a match indicates the reception of a wakeup frame.

Table 3.19 indicates the cases that produce a wake when the [Wakeup Frame Enable \(WAKE_EN\)](#) bit of the [Wakeup Control and Status Register \(WUCSR\)](#) is set. All other cases do not generate a wake.

Table 3.19 Wakeup Generation Cases

FILTER ENABLED (Note 3.2)	CRC MATCH (Note 3.3)	GLOBAL UNICAST ENABLED (Note 3.4)	PASS REGULAR RECEIVE FILTER	ADDRESS TYPE (Note 3.5)	BROAD-CAST FRAME	MULTI-CAST FRAME	UNICAST FRAME
Yes	Yes	x	x	x	Yes	No	No
Yes	Yes	Yes	x	x	No	No	Yes
Yes	Yes	x	Yes	Multicast (=1)	No	Yes	No
Yes	Yes	x	Yes	Unicast (=0)	No	No	Yes

Note 3.2 As determined by bit 0 of Filter i Command.

Note 3.3 CRC matches Filter i CRC-16 field.

Note 3.4 As determined by bit 9 of WUCSR.

Note 3.5 As determined by bit 2 of Filter i Command.

Note: x indicates "don't care".

3.5.4.1 Magic Packet Detection

Setting the Magic Packet Enable bit (MPEN) in the [Section 4.4.12, "Wakeup Control and Status Register \(WUCSR\)," on page 134](#), places the MAC in the "Magic Packet" detection mode. In this mode, normal data reception is disabled, and detection logic within the MAC examines receive data for a Magic Packet. The MAC can be programmed to assert the wake event interrupt to the Interrupt Controller on detection. Upon detection, the Magic Packet Received bit (MPR) in the WUCSR is set. When the Host clears the MPEN bit, normal receive operation will resume. Please refer to [Section 4.4.12, "Wakeup Control and Status Register \(WUCSR\)," on page 134](#) for additional information on this register

In Magic Packet mode, logic within the MAC constantly monitors each frame addressed to the node for a specific Magic Packet pattern. It checks only packets with the MAC's address or a broadcast address to meet the Magic Packet requirement. The MAC checks each received frame for the pattern 48'hFF_FF_FF_FF_FF_FF after the destination and source address field.

Then the MAC inspects the frame for 16 repetitions of the MAC address without any breaks or interruptions. In case of a break in the 16 address repetitions, the MAC scans for the 48'hFF_FF_FF_FF_FF_FF pattern again in the incoming frame.

The 16 repetitions may be anywhere in the frame but must be preceded by the synchronization stream. The device will also accept a multicast frame, as long as it detects the 16 duplications of the MAC address. If the MAC address of a node is 00h 11h 22h 33h 44h 55h, then the MAC scans for the following data sequence in an Ethernet frame:

```

Destination Address Source Address .....FF FF FF FF FF FF
00 11 22 33 44 55 00 11 22 33 44 55 00 11 22 33 44 55 00 11 22 33 44 55
00 11 22 33 44 55 00 11 22 33 44 55 00 11 22 33 44 55 00 11 22 33 44 55
00 11 22 33 44 55 00 11 22 33 44 55 00 11 22 33 44 55 00 11 22 33 44 55
00 11 22 33 44 55 00 11 22 33 44 55 00 11 22 33 44 55 00 11 22 33 44 55
...CRC
    
```

It should be noted that Magic Packet detection can be performed when LAN9420/LAN9420i is in any power management state.

3.5.5 Receive Checksum Offload Engine (RXCOE)

The receive checksum offload engine (RXCOE) provides assistance to the Host by calculating a 16-bit checksum for a received Ethernet frame. The RXCOE readily supports the following IEEE802.3 frame formats:

- Type II Ethernet frames
- SNAP encapsulated frames
- Support for up to 2, 802.1q VLAN tags

The resulting checksum value can also be modified by software to support other frame formats.

The RXCOE has two modes of operation. In mode 0, the RXCOE calculates the checksum between the first 14 bytes of the Ethernet frame and the FCS. This is illustrated in [Figure 3.19](#).

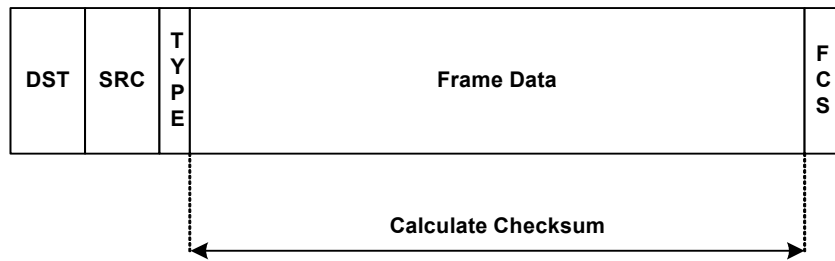

Figure 3.19 RXCOE Checksum Calculation

In mode 1, the RXCOE supports VLAN tags and a SNAP header. In this mode the RXCOE calculates the checksum at the start of L3 packet. The VLAN1 tag register is used by the RXCOE to indicate what protocol type is to be used to indicate the existence of a VLAN tag. This value is typically 8100h.

Example frame configurations:

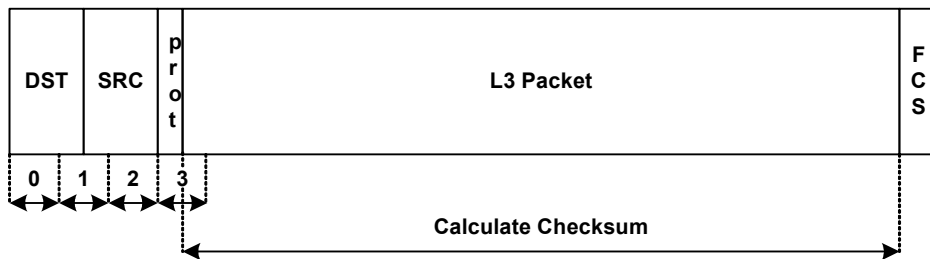

Figure 3.20 Type II Ethernet Frame

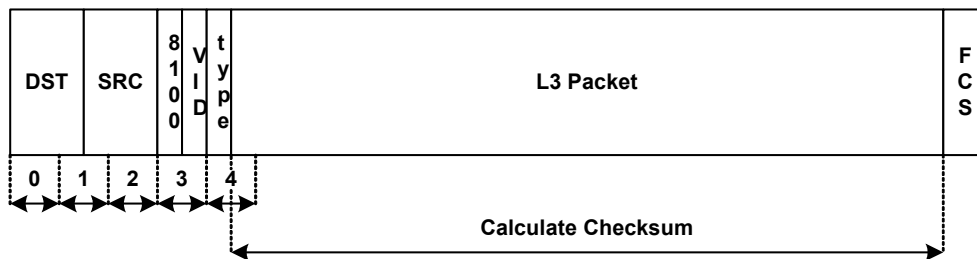
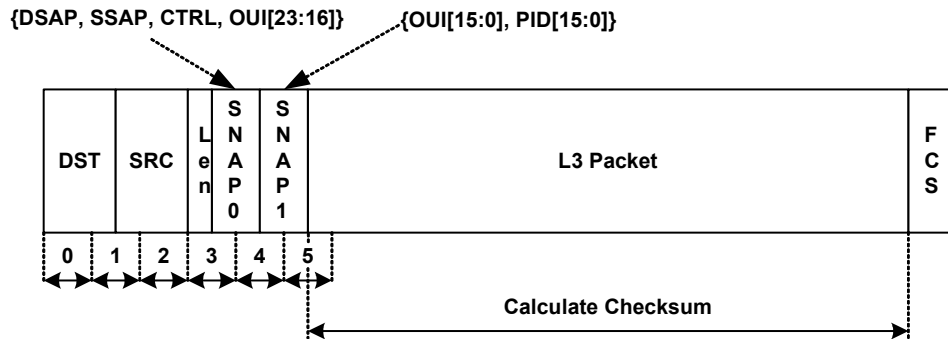
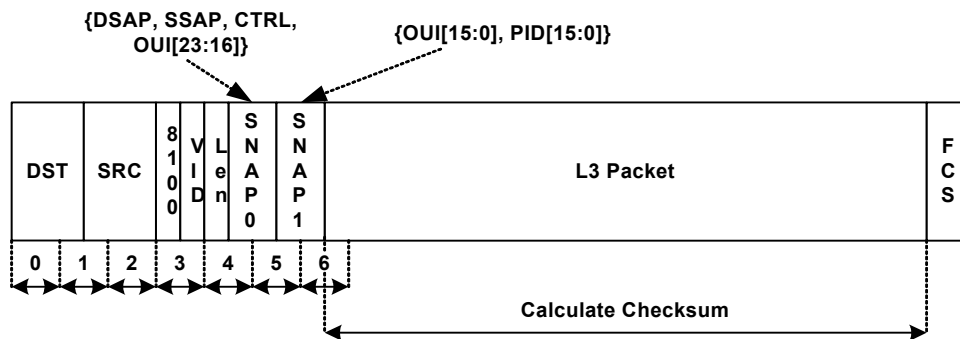
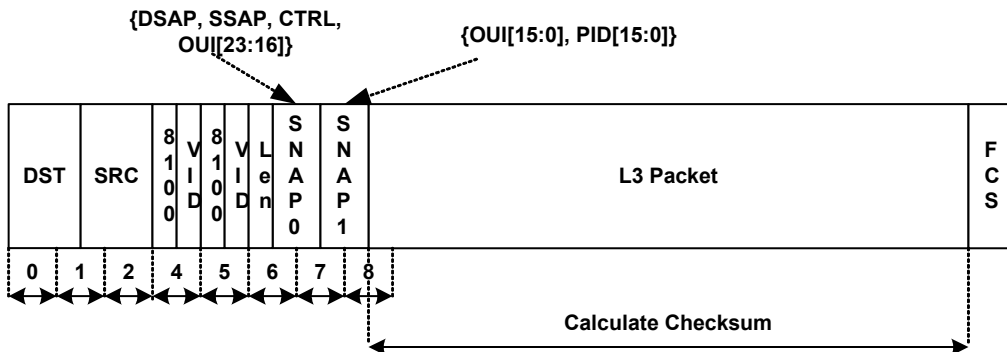

Figure 3.21 Ethernet Frame with VLAN Tag

Figure 3.22 Ethernet Frame with Length Field and SNAP Header

Figure 3.23 Ethernet Frame with VLAN Tag and SNAP Header

Figure 3.24 Ethernet Frame with multiple VLAN Tags and SNAP Header

The RXCOE supports a maximum of two VLAN tags. If there are more than two VLAN tags, the VLAN protocol identifier for the third tag is treated as an Ethernet type field. The checksum calculation will begin immediately after the type field.

Datasheet

The RXCOE resides in the RX path within the MAC. As the RXCOE receives an Ethernet frame it calculates the 16-bit checksum. The RXCOE passes the Ethernet frame to the DMAC with the checksum appended to the end of the frame. The RXCOE inserts the checksum immediately after the last byte of the Ethernet frame. The frame length field (FL) of receive descriptor 0 (RDES0) indicates that the frame size is increased by two bytes to accommodate the checksum.

Setting the RX_COE_EN bit in the [Checksum Offload Engine Control Register \(COE_CR\)](#) enables the RXCOE, while the RX_COE_MODE bit selects the operating mode. When the RXCOE is disabled, the received data is simply passed through the RXCOE unmodified.

Note: Software applications must stop the receiver and flush the RX data path before changing the state of the RX_COE_EN or RX_COE_MODE bits.

Note: When the RXCOE is enabled, automatic pad stripping must be disabled (PADSTR bit of the [MAC Control Register \(MAC_CR\)](#)) and vice versa. These functions cannot be enabled simultaneously.

3.5.5.1 RX Checksum Calculation

The checksum is calculated 16 bits at a time. In the case of an odd sized frame, an extra byte of zero is used to pad up to 16 bits.

Consider the following packet: DA, SA, Type, B0, B1, B2 ... BN, FCS

Let $[A, B] = A * 256 + B$;

If the packet has an even number of octets then

checksum = $[B1, B0] + C0 + [B3, B2] + C1 + \dots + [BN, BN-1] + CN-1$

Where C0, C1, ... CN-1 are the carry out results of the intermediate sums.

If the packet has an odd number of octets then

checksum = $[B1, B0] + C0 + [B3, B2] + C1 + \dots + [0, BN] + CN-1$

3.5.6 Transmit Checksum Offload Engine (TXCOE)

The transmit checksum offload engine (TXCOE) provides assistance to the Host by calculating a 16-bit checksum, typically for TCP, for a transmit Ethernet frame. The TXCOE calculates the checksum and inserts the results back into the data stream as it is transferred to the MAC.

When bit 27 of TDES1 (CK bit) is set in conjunction with bit 29 of TDES1 (FS bit) and bit 16 of the COE_CR register (TX_COE_EN), the TXCOE will perform a checksum calculation on the associated packet. When these three bits are set, a 32-bit TX checksum preamble must be pre-pended to the beginning of the TX packet (refer to [Table 3.20](#)). The TX checksum preamble instructs the TXCOE on the handling of the associated packet. Bits 11:0 of the TX checksum preamble define the byte offset at which the data checksum calculation will begin. The checksum calculation will begin at this offset and will continue until the end of the packet. The data checksum calculation must not begin in the MAC header (first 14 bytes) or in the last 4 bytes of the TX packet. When the calculation is complete, the checksum will be inserted into the packet at the byte offset defined by bits 27:16 of the TX checksum preamble. The TX checksum cannot be inserted in the MAC header (first 14 bytes) or in the last 4 bytes of the TX packet.

If the TX packet already includes a partial checksum calculation (perhaps inserted by an upper layer protocol), this checksum can be included in the hardware checksum calculation by setting the TXCSSP field in the TX checksum preamble to include the partial checksum. The partial checksum can be replaced by the completed checksum calculation by setting the TXCSLOC pointer to point to the location of the partial checksum.

Note: The TXCOE_MODE may only be changed if the TX path is disabled. If it is desired to change this value during run time, it is safe to do so only after the DMA is disabled and the MIL is empty.

Note: The TX checksum preamble must be DWORD-aligned.

Table 3.20 TX Checksum Preamble

BITS	DESCRIPTION
31:28	RESERVED
27:16	TXCSLOC - TX Checksum Location This field specifies the byte offset where the TX checksum will be inserted in the TX packet. The checksum will replace two bytes of data starting at this offset. Note: The TX checksum cannot be inserted in the MAC header (first 14 bytes) or in the last 4 bytes of the TX packet.
15:12	RESERVED
11:0	TXCSSP - TX Checksum Start Pointer This field indicates start offset, in bytes, where the checksum calculation will begin in the associated TX packet. Note: The data checksum calculation must not begin in the MAC header (first 14 bytes) or in the last 4 bytes of the TX packet.

3.5.6.1 TX Checksum Calculation

The TX checksum calculation is performed using the same operation as the RX checksum, with the exception that the calculation starts as indicated by the preamble, and the transmitted checksum is the one's-compliment of the final calculation.

Note: When the TX checksum offload feature is invoked, if the calculated checksum is 0000h, it is left unaltered. UDP checksums are optional under IPv4, and a zero checksum calculated by the TX checksum offload feature will erroneously indicate to the receiver that no checksum was calculated, however, the packet will typically not be rejected by the receiver. Under IPv6, however, according to RFC 2460, the UDP checksum is not optional. A calculated checksum that yields a result of zero must be changed to FFFFh for insertion into the UDP header. IPv6 receivers discard UDP packets containing a zero checksum. **Thus, this feature must not be used for UDP checksum calculation under IPv6.**

3.5.7 MAC Control and Status Registers (MCSR)

Please refer to [Section 4.4, "MAC Control and Status Registers \(MCSR\),"](#) on page 119 for a complete description of the MCSR.

3.6 10/100 Ethernet PHY

LAN9420/LAN9420i integrates an IEEE 802.3 Physical Layer for Twisted Pair Ethernet applications (PHY). The PHY can be configured for either 100 Mbps (100BASE-TX) or 10 Mbps (10BASE-T) Ethernet operation.

The PHY block includes:

- Support for auto-negotiation
- Automatic polarity detection and correction
- HP Auto-MDIX

Datasheet

- Energy detect
- Duplex, link activity and speed indicator LEDs
- Minimal external components are required for the utilization of the integrated PHY

Functionally, the PHY can be divided into the following sections:

- 100BASE-TX transmit and receive
- 10BASE-T transmit and receive
- Internal MII interface to the Ethernet Media Access Controller (MAC)
- Auto-negotiation to automatically determine the best speed and duplex possible
- Management Control to read status registers and write control registers

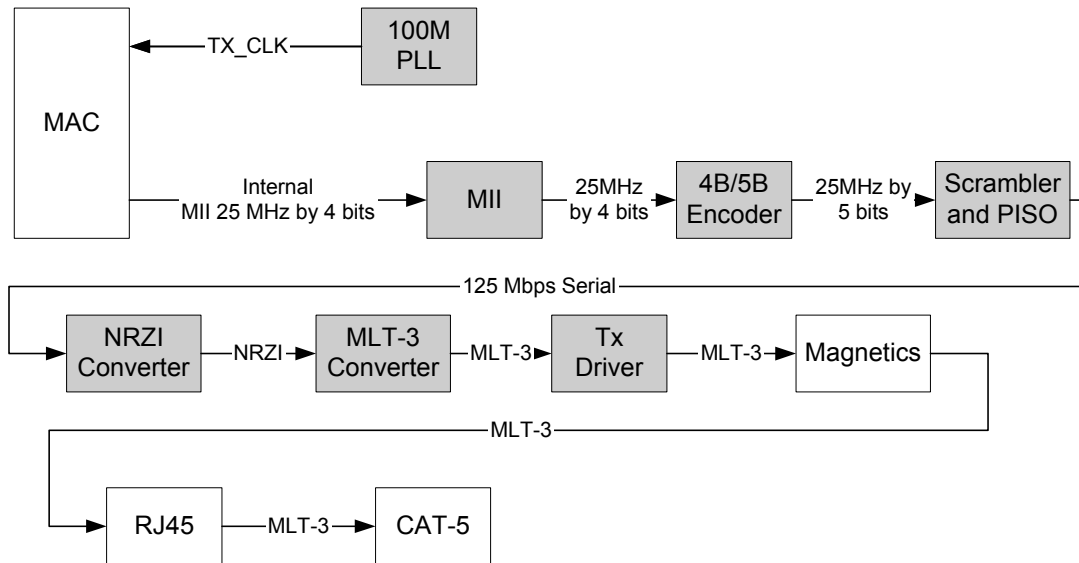

Figure 3.25 100BASE-TX Data Path

3.6.1 100BASE-TX Transmit

The data path of the 100BASE-TX is shown in [Figure 3.25](#). Each major block is explained below.

3.6.1.1 4B/5B Encoding

The transmit data passes from the MII block to the 4B/5B encoder. This block encodes the data from 4-bit nibbles to 5-bit symbols (known as “code-groups”) according to [Table 3.21](#). Each 4-bit data-nibble is mapped to 16 of the 32 possible code-groups. The remaining 16 code-groups are either used for control information or are not valid.

The first 16 code-groups are referred to by the hexadecimal values of their corresponding data nibbles, 0 through F. The remaining code-groups are given letter designations with slashes on either side. For example, an IDLE code-group is /I/, a transmit error code-group is /H/, etc.

The encoding process may be bypassed by clearing bit 6 of register 31. When the encoding is bypassed, the 5th transmit data bit is equivalent to TX_ER.

Table 3.21 4B/5B Code Table

CODE GROUP	SYM	RECEIVER INTERPRETATION			TRANSMITTER INTERPRETATION		
11110	0	0	0000	DATA	0	0000	DATA
01001	1	1	0001		1	0001	
10100	2	2	0010		2	0010	
10101	3	3	0011		3	0011	
01010	4	4	0100		4	0100	
01011	5	5	0101		5	0101	
01110	6	6	0110		6	0110	
01111	7	7	0111		7	0111	
10010	8	8	1000		8	1000	
10011	9	9	1001		9	1001	
10110	A	A	1010		A	1010	
10111	B	B	1011		B	1011	
11010	C	C	1100		C	1100	
11011	D	D	1101		D	1101	
11100	E	E	1110		E	1110	
11101	F	F	1111		F	1111	
11111	I	IDLE			Sent after /T/R until TX_EN		
11000	J	First nibble of SSD, translated to "0101" following IDLE, else RX_ER			Sent for rising TX_EN		
10001	K	Second nibble of SSD, translated to "0101" following J, else RX_ER			Sent for rising TX_EN		
01101	T	First nibble of ESD, causes de-assertion of CRS if followed by /R/, else assertion of RX_ER			Sent for falling TX_EN		
00111	R	Second nibble of ESD, causes de-assertion of CRS if following /T/, else assertion of RX_ER			Sent for falling TX_EN		
00100	H	Transmit Error Symbol			Sent for rising TX_ER		
00110	V	INVALID, RX_ER if during RX_DV			INVALID		
11001	V	INVALID, RX_ER if during RX_DV			INVALID		
00000	V	INVALID, RX_ER if during RX_DV			INVALID		
00001	V	INVALID, RX_ER if during RX_DV			INVALID		
00010	V	INVALID, RX_ER if during RX_DV			INVALID		
00011	V	INVALID, RX_ER if during RX_DV			INVALID		

Table 3.21 4B/5B Code Table (continued)

CODE GROUP	SYM	RECEIVER INTERPRETATION	TRANSMITTER INTERPRETATION
00101	V	INVALID, RX_ER if during RX_DV	INVALID
01000	V	INVALID, RX_ER if during RX_DV	INVALID
01100	V	INVALID, RX_ER if during RX_DV	INVALID
10000	V	INVALID, RX_ER if during RX_DV	INVALID

3.6.1.2 Scrambling

Repeated data patterns (especially the IDLE code-group) can have power spectral densities with large narrow-band peaks. Scrambling the data helps eliminate these peaks and spread the signal power more uniformly over the entire channel bandwidth. This uniform spectral density is required by FCC regulations to prevent excessive EMI from being radiated by the physical wiring.

The scrambler also performs the Parallel In Serial Out conversion (PISO) of the data.

3.6.1.3 NRZI and MLT3 Encoding

The scrambler block passes the 5-bit wide parallel data to the NRZI converter where it becomes a serial 125MHz NRZI data stream. The NRZI is encoded to MLT-3. MLT3 is a tri-level code where a change in the logic level represents a code bit “1” and the logic output remaining at the same level represents a code bit “0”.

3.6.1.4 100M Transmit Driver

The MLT3 data is then passed to the analog transmitter, which launches the differential MLT-3 signal, on outputs TPO+ and TPO-, to the twisted pair media via a 1:1 ratio isolation transformer. The 10BASE-T and 100BASE-TX signals pass through the same transformer so that common “magnetics” can be used for both. The transmitter drives into the 100Ω impedance of the CAT-5 cable. Cable termination and impedance matching require external components.

3.6.1.5 100M Phase Lock Loop (PLL)

The 100M PLL locks onto reference clock and generates the 125MHz clock used to drive the 125 MHz logic and the 100BASE-Tx Transmitter.

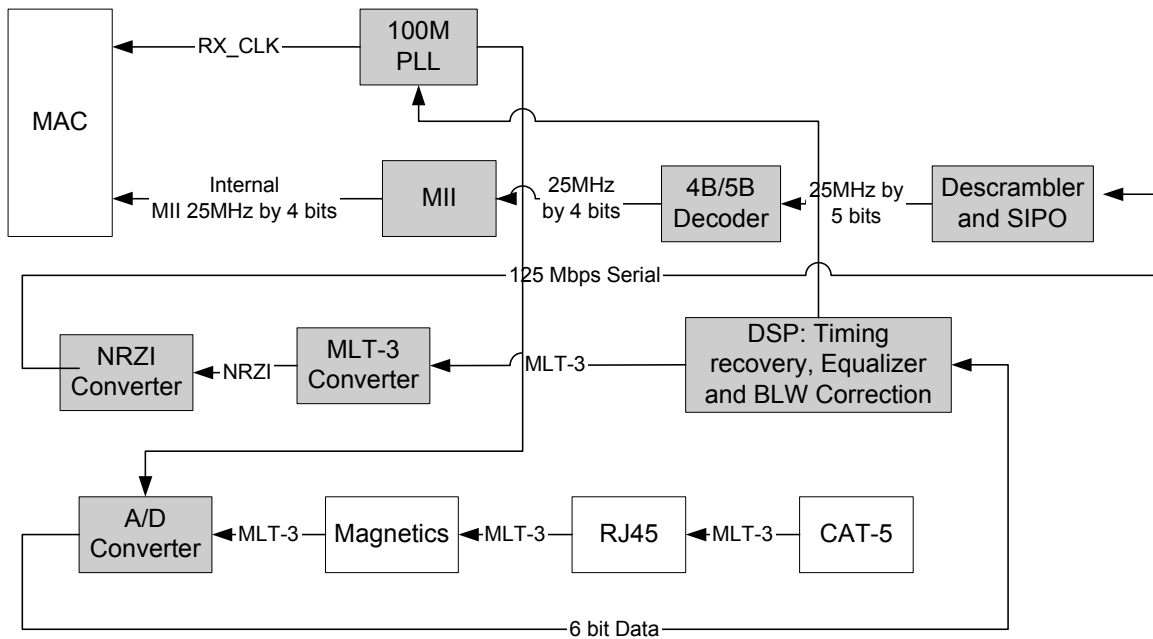
Figure 3.26 Receive Data Path

3.6.2 100BASE-TX Receive

The receive data path is shown in [Figure 3.26](#). Detailed descriptions follow.

3.6.2.1 100M Receive Input

The MLT-3 from the cable is fed into the PHY (on inputs TPI+ and TPI-) via a 1:1 ratio transformer. The ADC samples the incoming differential signal at a rate of 125M samples per second. Using a 64-level quantizer it generates 6 digital bits to represent each sample. The DSP adjusts the gain of the ADC according to the observed signal levels such that the full dynamic range of the ADC can be used.

3.6.2.2 Equalizer, Baseline Wander Correction and Clock and Data Recovery

The 6 bits from the ADC are fed into the DSP block. The equalizer in the DSP section compensates for phase and amplitude distortion caused by the physical channel consisting of magnetics, connectors, and CAT-5 cable. The equalizer can restore the signal for any good-quality CAT-5 cable between 1m and 150m.

If the DC content of the signal is such that the low-frequency components fall below the low frequency pole of the isolation transformer, then the droop characteristics of the transformer will become significant and Baseline Wander (BLW) on the received signal will result. To prevent corruption of the received data, the PHY corrects for BLW and can receive the ANSI X3.263-1995 FDDI TP-PMD defined “killer packet” with no bit errors.

The 100M PLL generates multiple phases of the 125MHz clock. A multiplexer, controlled by the timing unit of the DSP, selects the optimum phase for sampling the data. This is used as the received recovered clock. This clock is used to extract the serial data from the received signal.

3.6.2.3 NRZI and MLT-3 Decoding

The DSP generates the MLT-3 recovered levels that are fed to the MLT-3 converter. The MLT-3 is then converted to an NRZI data stream.

Datasheet

3.6.2.4 Descrambling

The descrambler performs an inverse function to the scrambler in the transmitter and also performs the Serial In Parallel Out (SIPO) conversion of the data.

During reception of IDLE (/I/) symbols, the descrambler synchronizes its descrambler key to the incoming stream. Once synchronization is achieved, the descrambler locks on this key and is able to descramble incoming data.

Special logic in the descrambler ensures synchronization with the remote PHY by searching for IDLE symbols within a window of 4000 bytes (40us). This window ensures that a maximum packet size of 1514 bytes, allowed by the IEEE 802.3 standard, can be received with no interference. If no IDLE-symbols are detected within this time-period, receive operation is aborted and the descrambler re-starts the synchronization process.

The descrambler can be bypassed by setting bit 0 of register 31.

3.6.2.5 Alignment

The de-scrambled signal is then aligned into 5-bit code-groups by recognizing the /J/K/ Start-of-Stream Delimiter (SSD) pair at the start of a packet. Once the code-word alignment is determined, it is stored and utilized until the next start of frame.

3.6.2.6 5B/4B Decoding

The 5-bit code-groups are translated into 4-bit data nibbles according to the 4B/5B table. The SSD, /J/K/, is translated to "0101 0101" as the first 2 nibbles of the MAC preamble. Reception of the SSD causes the PHY to assert the internal RX_DV signal, indicating that valid data is available on the Internal RXD bus. Successive valid code-groups are translated to data nibbles. Reception of either the End of Stream Delimiter (ESD) consisting of the /T/R/ symbols, or at least two /I/ symbols causes the PHY to de-assert the internal carrier sense and RX_DV.

These symbols are not translated into data.

3.6.2.7 Receiver Errors

During a frame, unexpected code-groups are considered receive errors. Expected code groups are the DATA set (0 through F), and the /T/R/ (ESD) symbol pair. When a receive error occurs, the internal MII's RX_ER signal is asserted and arbitrary data is driven onto the internal receive data bus (RXD) to the MAC. Should an error be detected during the time that the /J/K/ delimiter is being decoded (bad SSD error), RX_ER is asserted and the value 1110b is driven onto the internal receive data bus (RXD) to the MAC. Note that the internal MII's data valid signal (RX_DV) is not yet asserted when the bad SSD occurs.

3.6.3 10BASE-T Transmit

Data to be transmitted comes from the MAC. The 10BASE-T transmitter receives 4-bit nibbles from the internal MII at a rate of 2.5MHz and converts them to a 10Mbps serial data stream. The data stream is then Manchester-encoded and sent to the analog transmitter, which drives a signal onto the twisted pair via the external magnetics.

The 10M transmitter uses the following blocks:

- MII (digital)
- TX 10M (digital)
- 10M Transmitter (analog)
- 10M PLL (analog)

3.6.3.1 10M Transmit Data Across the Internal MII Bus

The MAC controller drives the transmit data onto the internal TXD BUS. When the controller has driven TX_EN high to indicate valid data, the data is latched by the MII block on the rising edge of TX_CLK. The data is in the form of 4-bit wide 2.5MHz data.

3.6.3.2 Manchester Encoding

The 4-bit wide data is sent to the TX10M block. The nibbles are converted to a 10Mbps serial NRZI data stream. The 10M PLL locks onto the external clock or internal oscillator and produces a 20MHz clock. This is used to Manchester encode the NRZ data stream. When no data is being transmitted (internal TX_EN is low), the TX10M block outputs Normal Link Pulses (NLPs) to maintain communications with the remote link partner.

3.6.3.3 10M Transmit Drivers

The Manchester encoded data is sent to the analog transmitter where it is shaped and filtered before being driven out as a differential signal across the TPO+ and TPO- outputs.

3.6.4 10BASE-T Receive

The 10BASE-T receiver gets the Manchester-encoded analog signal from the cable via the magnetics. It recovers the receive clock from the signal and uses this clock to recover the NRZI data stream. This 10M serial data is converted to 4-bit data nibbles which are passed to the controller across the internal MII at a rate of 2.5MHz.

This 10M receiver uses the following blocks:

- Filter and SQUELCH (analog)
- 10M PLL (analog)
- RX 10M (digital)
- MII (digital)

3.6.4.1 10M Receive Input and Squelch

The Manchester signal from the cable is fed into the PHY (on inputs TPI+ and TPI-) via 1:1 ratio magnetics. It is first filtered to reduce any out-of-band noise. It then passes through a SQUELCH circuit. The SQUELCH is a set of amplitude and timing comparators that normally reject differential voltage levels below 300mV and detect and recognize differential voltages above 585mV.

3.6.4.2 Manchester Decoding

The output of the SQUELCH goes to the RX10M block where it is validated as Manchester encoded data. The polarity of the signal is also checked. If the polarity is reversed (local TPI+ is connected to TPI- of the remote partner and vice versa), then this is identified and corrected. The reversed condition is indicated by the flag "XPOL", bit 4 in register 27. The 10M PLL is locked onto the received Manchester signal and from this, generates the received 20MHz clock. Using this clock, the Manchester encoded data is extracted and converted to a 10MHz NRZI data stream. It is then converted from serial to 4-bit wide parallel data.

The RX10M block also detects valid 10BASE-T IDLE signals - Normal Link Pulses (NLPs) - to maintain the link.

3.6.4.3 Jabber Detection

Jabber is a condition in which a station transmits for a period of time longer than the maximum permissible packet length, usually due to a fault condition, that results in holding the internal TX_EN input for a long period. Special logic is used to detect the jabber state and abort the transmission to

the line, within 45ms. Once TX_EN is de-asserted, the logic resets the jabber condition. Bit 1 of the Basic Status register indicates that a jabber condition was detected.

3.6.5 Auto-negotiation

The purpose of the Auto-negotiation function is to automatically configure the PHY to the optimum link parameters based on the capabilities of its link partner. Auto-negotiation is a mechanism for exchanging configuration information between two link-partners and automatically selecting the highest performance mode of operation supported by both sides. Auto-negotiation is fully defined in clause 28 of the IEEE 802.3 specification.

Once auto-negotiation has completed, information about the resolved link can be passed back to the controller via the internal Serial Management Interface (SMI). The results of the negotiation process are reflected in the Speed Indication bits in register 31, as well as the Auto Negotiation Link Partner Ability Register (Register 5).

The auto-negotiation protocol is a purely physical layer activity and proceeds independently of the MAC controller.

The advertised capabilities of the PHY are stored in register 4 of the SMI registers. The default advertised by the PHY is determined by user-defined on-chip signal options.

The following blocks are activated during an Auto-negotiation session:

- Auto-negotiation (digital)
- 100M ADC (analog)
- 100M PLL (analog)
- 100M equalizer/BLW/clock recovery (DSP)
- 10M SQUELCH (analog)
- 10M PLL (analog)
- 10M Transmitter (analog)

When enabled, auto-negotiation is started by the occurrence of one of the following events:

- Chip-level reset
- Software reset
- Link status down
- Setting register 0, bit 9 high (auto-negotiation restart)

On detection of one of these events, the PHY begins auto-negotiation by transmitting bursts of Fast Link Pulses (FLP). These are bursts of link pulses from the 10M transmitter. They are shaped as Normal Link Pulses and can pass uncorrupted down CAT-3 or CAT-5 cable. A Fast Link Pulse Burst consists of up to 33 pulses. The 17 odd-numbered pulses, which are always present, frame the FLP burst. The 16 even-numbered pulses, which may be present or absent, contain the data word being transmitted. Presence of a data pulse represents a “1”, while absence represents a “0”.

The data transmitted by an FLP burst is known as a “Link Code Word.” These are defined fully in IEEE 802.3 clause 28. In summary, the PHY advertises 802.3 compliance in its selector field (the first 5 bits of the Link Code Word). It advertises its technology ability according to the bits set in register 4 of the SMI registers.

There are 4 possible matches of the technology abilities. In the order of priority these are:

- 100M full-duplex (Highest priority)
- 100M half-duplex
- 10M full-duplex
- 10M half-duplex

If the full capabilities of the PHY are advertised (100M, full-duplex), and if the link partner is capable of 10M and 100M, then auto-negotiation selects 100M as the highest performance mode. If the link partner is capable of half and full-duplex modes, then auto-negotiation selects full-duplex as the highest performance operation.

Once a capability match has been determined, the link code words are repeated with the acknowledge bit set. Any difference in the main content of the link code words at this time will cause auto-negotiation to re-start. Auto-negotiation will also re-start if not all of the required FLP bursts are received.

Writing register 4 bits [8:5] allows software control of the capabilities advertised by the PHY. Writing register 4 does not automatically re-start auto-negotiation. Register 0, bit 9 must be set before the new abilities will be advertised. Auto-negotiation can also be disabled via software by clearing register 0, bit 12.

LAN9420/LAN9420i does not support "Next Page" capability.

3.6.6 Parallel Detection

If LAN9420/LAN9420i is connected to a device lacking the ability to auto-negotiate (i.e. no FLPs are detected), it is able to determine the speed of the link based on either 100M MLT-3 symbols or 10M Normal Link Pulses. In this case the link is presumed to be half-duplex per the IEEE standard. This ability is known as "Parallel Detection". This feature ensures inter operability with legacy link partners. If a link is formed via parallel detection, then bit 0 in register 6 is cleared to indicate that the Link Partner is not capable of auto-negotiation. The Ethernet MAC has access to this information via the management interface. If a fault occurs during parallel detection, bit 4 of register 6 is set.

Register 5 is used to store the Link Partner Ability information, which is coded in the received FLPs. If the Link Partner is not auto-negotiation capable, then register 5 is updated after completion of parallel detection to reflect the speed capability of the Link Partner.

3.6.6.1 Re-starting Auto-negotiation

Auto-negotiation can be re-started at any time by setting register 0, bit 9. Auto-negotiation will also re-start if the link is broken at any time. A broken link is caused by signal loss. This may occur because of a cable break, or because of an interruption in the signal transmitted by the Link Partner. Auto-negotiation resumes in an attempt to determine the new link configuration.

If the management entity re-starts Auto-negotiation by writing to bit 9 of the control register, LAN9420/LAN9420i will respond by stopping all transmission/receiving operations. Once the break_link_timer is done, in the Auto-negotiation state-machine (approximately 1200ms) the auto-negotiation will re-start. The Link Partner will have also dropped the link due to lack of a received signal, so it too will resume auto-negotiation.

3.6.6.2 Disabling Auto-negotiation

Auto-negotiation can be disabled by setting register 0, bit 12 to zero. The device will then force its speed of operation to reflect the information in register 0, bit 13 (speed) and register 0, bit 8 (duplex). The speed and duplex bits in register 0 should be ignored when auto-negotiation is enabled.

3.6.6.3 Half vs. Full-Duplex

Half-duplex operation relies on the CSMA/CD (Carrier Sense Multiple Access / Collision Detect) protocol to handle network traffic and collisions. In this mode, the carrier sense signal, CRS, responds to both transmit and receive activity. In this mode, If data is received while the PHY is transmitting, a collision results.

In full-duplex mode, the PHY is able to transmit and receive data simultaneously. In this mode, CRS responds only to receive activity. The CSMA/CD protocol does not apply and collision detection is disabled.

3.6.7 HP Auto-MDIX

HP Auto-MDIX facilitates the use of CAT-3 (10 BASE-T) or CAT-5 (100 BASE-T) media UTP interconnect cable without consideration of interface wiring scheme. If a user plugs in either a direct connect LAN cable, or a cross-over patch cable, as shown in [Figure 3.27 on page 73](#), the LAN9420/LAN9420i Auto-MDIX PHY is capable of configuring the TPO+/TPO- and TPI+/TPI- twisted pair pins for correct transceiver operation.

The internal logic of the device detects the TX and RX pins of the connecting device. Since the RX and TX line pairs are interchangeable, special PCB design considerations are needed to accommodate the symmetrical magnetics and termination of an Auto-MDIX design.

The Auto-MDIX function can be disabled through an internal register 27.15, or the external AUTOMDIX_EN configuration strap. When Auto-MDIX mode is disabled (27.15 = 1), the TX and RX pins can be configured as desired using the MDIX State (27.13) control bit.

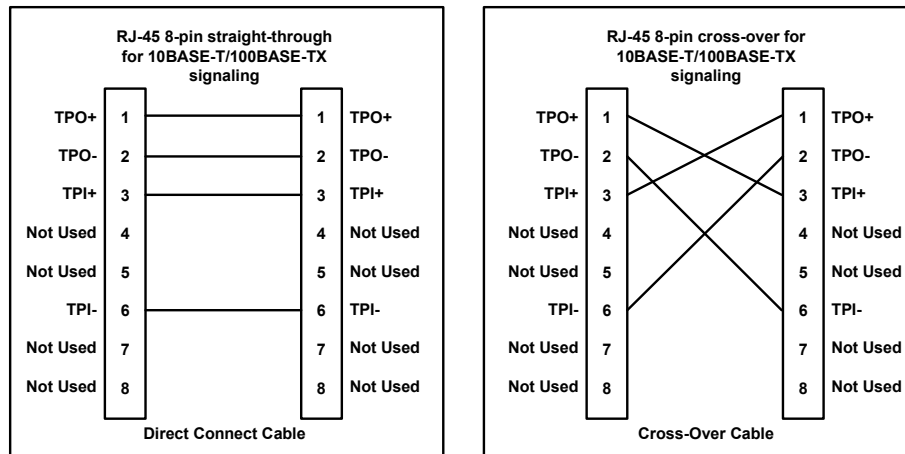

Figure 3.27 Direct Cable Connection vs. Cross-Over Cable Connection

3.6.8 PHY Power-Down Modes

There are 2 power-down modes for the PHY as discussed in the following sections.

3.6.8.1 General Power-Down

This power-down is controlled by register 0, bit 11. In this mode the PHY, except the management interface, is powered-down and stays in that condition as long as PHY register bit 0.11 is HIGH. When bit 0.11 is cleared, the PHY powers up and is automatically reset. Please refer to [Section 4.5.1, "Basic Control Register," on page 137](#) for additional information on this register.

Note: For maximum power savings, auto-negotiation should be disabled before enabling the General Power-Down mode.

3.6.8.2 Energy Detect Power-Down

This power-down mode is activated by setting the PHY register bit 17.13 to 1. Please refer to [Section 4.5.8, "Mode Control/Status," on page 144](#) for additional information on this register. In this mode when no energy is present on the line, the PHY is powered down, with the exception of the management interface, the SQUELCH circuit and the ENERGYON logic. The ENERGYON logic is used to detect the presence of valid energy from 100BASE-TX, 10BASE-T, or Auto-negotiation signals

In this mode, when the ENERGYON signal is low, the PHY is powered-down, and nothing is transmitted. When energy is received - link pulses or packets - the internal ENERGYON signal is asserted, and the PHY powers-up. It automatically resets itself into the state it had prior to power-down, and asserts the INT7 bit of the PHY [Interrupt Source Flag](#) register. If the ENERGYON interrupt is enabled, this event will cause a PHY interrupt to the Interrupt Controller and the power management event detection logic.

The first and possibly the second packet to activate ENERGYON may be lost.

When 17.13 is low, energy detect power-down is disabled.

3.6.9 PHY Resets

In addition to a chip-level reset, the PHY supports two software-initiated resets. These are discussed in the following sections.

3.6.9.1 PHY Soft Reset via PMT_CTRL bit 10 (PHY_RST)

The PHY soft reset is initiated by writing a '1' to bit 10 of the PMT_CTRL register (PHY_RST). This self-clearing bit will return to '0' after approximately 100 μ s, at which time the PHY reset is complete.

3.6.9.2 PHY Soft Reset via PHY Basic Control Register bit 15 (PHY Reg. 0.15)

The PHY Reg. 0.15 Soft Reset is initiated by writing a '1' to bit 15 of the PHY's Basic Control Register. This self-clearing bit will return to '0' after approximately 256 μ s, at which time the PHY reset is complete. The BCR reset initializes the logic within the PHY, with the exception of register bits marked as NASR (Not Affected by Software Reset).

3.6.10 Required Ethernet Magnetics

The magnetics selected for use with LAN9420/LAN9420i should be an Auto-MDIX style magnetic available from several vendors. The user is urged to review SMSC Application Note 8.13 "Suggested Magnetics" for the latest qualified and suggested magnetics. Vendors and part numbers are provided in this application note.

3.6.11 PHY Registers

Please refer to [Section 4.5, "PHY Registers," on page 136](#) for a complete description of the PHY registers.

3.7 Power Management

3.7.1 Overview

LAN9420/LAN9420i supports the mandatory D0, D3_{HOT} and D3_{COLD} power states. LAN9420/LAN9420i can signal a wake event detection by asserting the nPME pin. The nPME signal can be generated in all states, including (optionally) the D3_{COLD} state. LAN9420/LAN9420i can assert the nPME signal upon detection of various power management events, such as an Ethernet "Wake On LAN", or upon detection of an Ethernet link status change.

As a result of the nPME assertion by the device, the PCI Host can reconfigure the power management state. This mechanism is used, for example, when LAN9420/LAN9420i is in low power mode and must be restored to a functional state, as a result of the detection of “Wake On LAN” event. The Host can respond to the subsequent nPME assertion by changing the [Power Management State \(PM_STATE\)](#) bits in the [PCI Power Management Control and Status Register \(PCI_PMCSR\)](#) to restore LAN9420/LAN9420i to the D0 state.

As a single function device, LAN9420/LAN9420i implements a [PCI Power Management Capabilities Register \(PCI_PMC\)](#) and a [PCI Power Management Control and Status Register \(PCI_PMCSR\)](#), which are mapped into the PCI configuration space at addresses 78h and 7Ch, respectively. The [3.3Vaux Power Supply Current Draw \(AUX_CURRENT\)](#) field of the PCI_PMC register is dependant on the setting of the external VAUXDET pin. The Data_Scale and Data_Select fields of the PCI_PMCSR register will always return zero, as the Data Register is not implemented.

LAN9420/LAN9420i complies with Revision 1.1 of the *PCI Bus Power Management Interface Specification, V2.0* of the *Network Device Class Specification* and Revision 3.0 of the *Advanced Configuration and Power Interface Specification (ACPI specification)*.

Refer to [Section 5.3, "Power Consumption," on page 157](#) for power consumption in the various power management states.

3.7.2 Related External Signals and Power Supplies

The following external signals are provided in support of PCI power management:

- nPME: LAN9420/LAN9420i can assert this signal upon detection of an enabled power management event.

Note: The nPME signal requires external isolation if the system supports wake from B3 and the LAN9420/LAN9420i's VAUXDET=0 (i.e., the system is powered, but LAN9420/LAN9420i is not)

- VAUXDET: This signal enables LAN9420/LAN9420i's ability to detect power management events and assert nPME from the D3_{COLD} state (wake from D3_{COLD}). When tied to the PCI system's 3.3Vaux power supply, wake from D3_{COLD} is enabled. When tied to ground, wake from D3_{COLD} is disabled.
- PWRGOOD: If VAUXDET is low (wake from D3_{COLD} is disabled) PWRGOOD must be tied to +3.3V power. If VAUXDET is connected to 3.3Vaux (wake from D3_{COLD} is enabled), LAN9420/LAN9420i uses PWRGOOD to determine the state of the system's +3.3V power supply. When VAUXDET is high, the device is isolated from the PCI bus when PWRGOOD is deasserted and will ignore all PCI transactions, including PCICLK and PCInRST.

LAN9420/LAN9420i requires the following external 3.3V power supplies:

- VDD33IO, VDD33A, VDD33BIAS

The connection of the device's 3.3V power pins varies depending on the requirement for support of wake from D3_{COLD}. If wake from D3_{COLD} is enabled (VAUXDET is connected to 3.3Vaux), the 3.3V power pins must be connected to the PCI system's 3.3Vaux power supply. If wake from D3_{COLD} is disabled, (VAUXDET is connected to VSS), the 3.3V power pins must be connected to the system's +3.3V power. Please refer to [Chapter 2, "Pin Description and Configuration," on page 15](#) for more information on the LAN9420/LAN9420i power supplies.

Note: The LAN9420/LAN9420i device also requires 1.8V, but this is supplied by an internal regulator and connection does not vary. Since the 1.8V supply is derived from VDD33IO, there is no need to discuss it separately.

3.7.3 Device Clocking

LAN9420/LAN9420i requires a fixed-frequency 25MHz clock source. This is typically provided by attaching a 25MHz crystal to the XI and XO pins. The clock can optionally be provided by driving the

XI input pin with a single-ended 25MHz clock source. If a single-ended source is selected, the clock input must run continuously for normal device operation.

Internally, LAN9420/LAN9420i generates its required clocks with a phase-locked loop (PLL). The LAN9420/LAN9420i reduces its power consumption in the D3 state by disabling its internal PLL and derivative clocks. The 25MHz clock remains operational in all states where power is applied.

Please refer to [Section 5.9, "Clock Circuit," on page 167](#) for more information on clock requirements.

3.7.4 Power States

This section describes the operation of LAN9420/LAN9420i in each device power state ('D' states) as well as the events required to cause state transitions. LAN9420/LAN9420i's behavior is dependant on the device's VAUXDET pin (the device's ability to detect wake events in D3_{COLD}). Specific behaviors are discussed in the sections that follow.

Device power states and associated state transitions are illustrated in [Figure 3.28](#) below. Note that [Figure 3.28](#) includes the system's mechanical off (G3) power state for illustrative purposes. This is the G3 state as defined by the ACPI specification. In this state all power (+3.3V and 3.3Vaux) is off.

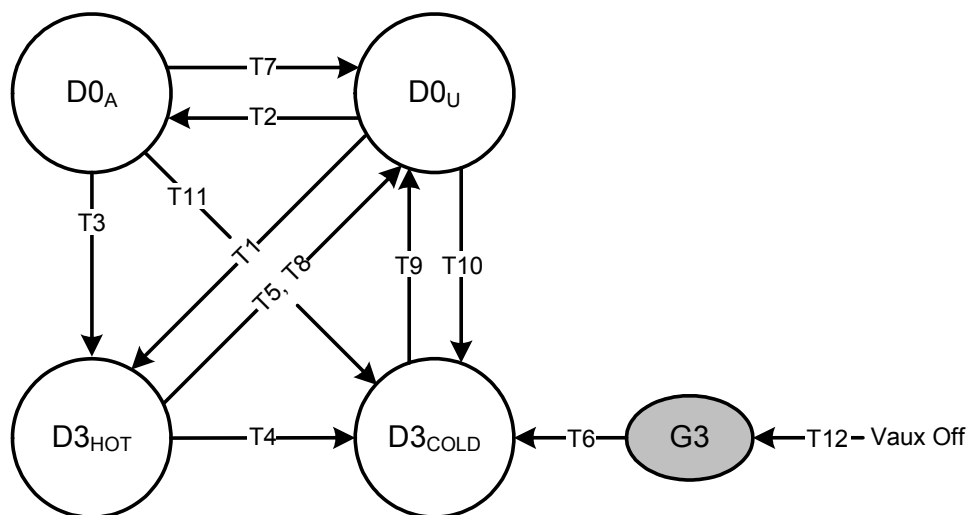

Figure 3.28 LAN9420/LAN9420i Device Power States

Some power state transitions may place the PHY in the General Power-Down state as noted in the sections that follow. Please refer to [Section 3.6.8.1, "General Power-Down," on page 73](#) for more information on this mode of operation.

3.7.4.1 G3 State (Mechanical Off)

G3 is not a device power state, but is discussed here for illustrative purposes. In the G3 state all PCI power is off. In this state all device context is lost.

3.7.4.1.1 POWER MANAGEMENT EVENTS IN G3

LAN9420/LAN9420i does not detect power management events in the G3 state.

3.7.4.1.2 EXITING THE G3 STATE

When the system leaves the G3 state, the device will behave as follows. State transitions are illustrated in [Figure 3.28 on page 76](#).

Datasheet

- G3 to D3_{COLD} (T6): This transition occurs when VAUXDET is connected to the PCI 3.3Vaux power supply and all power is off (PCInRST=X, PM_STATE=X, VAUXDET=0, PWRGOOD=0) and then 3.3Vaux is applied (PCInRST=0, PM_STATE=X, VAUXDET=0 to 1, PWRGOOD=0). LAN9420/LAN9420i detects the application of auxiliary power and asserts its internal power-on reset (POR). POR resets the **PME Enable (PME_EN)** bit of the **PCI Power Management Control and Status Register (PCI_PMCSR)** and sets the **Power Management State (PM_STATE)** field of the **PCI Power Management Control and Status Register (PCI_PMCSR)** to the “D3” state. The internal PHY is held in the general-power down state and the device is powered by the PCI 3.3Vaux supply. The device will remain in the D3_{COLD} state until PCI power is applied.

3.7.4.2 D0_{UNINITIALIZED} State (D0_U)

In this state all internal clocks are enabled, but the device has not been initialized by the PCI Host. The device cannot receive or transmit Ethernet data. Depending on the reason for the transition into D0_U, the PHY may have been reset and may be in the General Power-Down state. These conditions are noted in the discussions that follow.

In D0_U the device will respond to all PCI accesses. While in this state, the **Power Management State (PM_STATE)** field of the **PCI Power Management Control and Status Register (PCI_PMCSR)** will indicate a setting of 00b (D0 state).

3.7.4.2.1 EXITING THE D0_U STATE

The device will exit the D0_U state under the following conditions. State transitions are illustrated in [Figure 3.28 on page 76](#).

- D0_U to D3_{HOT} (T1): This transition occurs when the Host system selects the “D3” state in the **Power Management State (PM_STATE)** field of the **PCI Power Management Control and Status Register (PCI_PMCSR)**. PCI main and auxiliary power (if used) remain on (PCInRST=1, PM_STATE=00b to 11b, VAUXDET=X, PWRGOOD=1).
- D0_U to D0_A (T2): This transition occurs when the device is in the D0_U uninitialized state and is then configured by the PCI Host. (PCInRST=1, PM_STATE=00b, VAUXDET=X, PWRGOOD=1).
- D0_U to D3_{COLD} (T10): This transition occurs when all power supplies are operational and the **Power Management State (PM_STATE)** field of the **PCI Power Management Control and Status Register (PCI_PMCSR)** is set to “D0”, but the device has not yet been initialized, and then PCI power is turned off and 3.3Vaux is still operational (PCInRST=1, PM_STATE=00b, VAUXDET=1, PWRGOOD=1 to 0). The internal PHY is reset and is placed in the General Power-Down mode on this transition. Note that if VAUXDET=0, the device is being powered from the PCI +3.3V supply and will turn off (G3) when PCI power is removed.
- D0_U to G3 (T12): This transition occurs when all power supplies are turned off (PCInRST=X, PM_STATE=XXb, VAUXDET=1 to 0, PWRGOOD=1 to 0). For example, total power failure.

3.7.4.3 D0_{ACTIVE} State (D0_A)

In this state all internal clocks are operational and the device is able to receive and transmit Ethernet data. This is the normal operational state of the device.

In D0_A the device will respond to all PCI accesses. While in this state, the **Power Management State (PM_STATE)** field of the **PCI Power Management Control and Status Register (PCI_PMCSR)** will indicate a setting of 00b (D0 state).

3.7.4.3.1 POWER MANAGEMENT EVENTS IN D0_A

If configured to do so, the device is capable of detecting MAC (WOL, Magic Packet) and PHY (link status change) wake events and is capable of asserting a PCI interrupt (nINT) or nPME as a result of detection. Refer to section [Section 3.7.6, "Detecting Power Management Events," on page 81](#) for more information.

3.7.4.3.2 EXITING THE D0_A STATE

The device will exit the D0_A state under the following conditions. State transitions are illustrated in [Figure 3.28 on page 76](#).

- D0_A to D3_{HOT} (T3): This transition occurs when, during normal device operation, the Host system selects the “D3” state in the [Power Management State \(PM_STATE\)](#) field of the [PCI Power Management Control and Status Register \(PCI_PMCSR\)](#). (PCInRST=1, PM_STATE=00b to 11b, VAUXDET=X, PWRGOOD=1). If the [PME Enable \(PME_EN\)](#) bit in the [PCI Power Management Control and Status Register \(PCI_PMCSR\)](#) is cleared, the internal PHY is reset and is placed in the General Power-Down mode on this transition. If [PME Enable \(PME_EN\)](#) is set, it is assumed that the device will be required to detect Ethernet power management events and the PHY is not reset or placed in General Power-Down mode.
- D0_A to D0_U (T7): This transition occurs when PCInRST is asserted while in the D0_A state (PCInRST=1 to 0, PM_STATE=00b, VAUXDET=X, PWRGOOD=1).
- D0_A to D3_{COLD} (T11): This transition occurs when all power supplies are operational and the device has been initialized and the [Power Management State \(PM_STATE\)](#) field of the [PCI Power Management Control and Status Register \(PCI_PMCSR\)](#) is set to “D0”, and then PCI power is turned off and 3.3Vaux is still operational (PCInRST=1, PM_STATE=00b, VAUXDET=1, PWRGOOD=1 to 0). The internal PHY is reset and is placed in the General Power-Down mode on this transition. Note that if VAUXDET=0, the device is being powered from the PCI +3.3V supply and will turn off (G3) when PCI power is removed.
- D0_A to G3 (T12): This transition occurs when all power supplies are turned off (PCInRST=X, PM_STATE=XXb, VAUXDET=1 to 0, PWRGOOD=1 to 0). For example, total power failure.

3.7.4.4 The D3_{HOT} State

In this state the PCI power is on, but normal Ethernet receive and transmit operation is disabled. In D3_{HOT} power is reduced by disabling the internal PLL and derivative clocks. If the [PME Enable \(PME_EN\)](#) bit in the [PCI Power Management Control and Status Register \(PCI_PMCSR\)](#) is cleared, power is also conserved by placing the internal PHY into General Power-Down mode on transition to this state.

In D3_{HOT} PCI configuration accesses are permitted, but the device will not respond to PCI memory or I/O accesses. While in this state, the [Power Management State \(PM_STATE\)](#) field of the [PCI Power Management Control and Status Register \(PCI_PMCSR\)](#) will indicate a setting of 11b (D3 state).

3.7.4.4.1 POWER MANAGEMENT EVENTS IN D3_{HOT}

If configured to do so, the device is capable of detecting MAC (WOL, Magic Packet) and PHY (link status change) wake events and is capable of asserting nPME as a result of detection. Refer to [Section 3.7.6, "Detecting Power Management Events," on page 81](#) for more information.

3.7.4.4.2 EXITING THE D3_{HOT} STATE

The device will exit the D3_{HOT} state under the following conditions. State transitions are illustrated in [Figure 3.28 on page 76](#).

- D3_{HOT} to D3_{COLD} (T4): This transition occurs after the device has been placed in the D3_{HOT} state by the Host system and then PCI power is turned off, but PCI 3.3Vaux remains operational (PCInRST=X, PM_STATE=11b, VAUXDET=1, PWRGOOD=1 to 0). In this state the device is powered by the PCI 3.3Vaux supply.
- D3_{HOT} to D0_U (T5): This transition occurs when the device is in the D3_{HOT} state and Host system selects the “D0” state in the [Power Management State \(PM_STATE\)](#) field of the [PCI Power Management Control and Status Register \(PCI_PMCSR\)](#) (PCInRST=1, PM_STATE=11b to 00b, VAUXDET=X, PWRGOOD=1). A D3 Transition Reset (D3RST) occurs during this transition. Refer to [Section 3.7.5, "Resets," on page 79](#) to for more information on this reset.

Datasheet

- D3_{HOT} to D0_U (T8): This transition occurs when PCInRST is asserted while in the D3_{HOT} state (PCInRST=1 to 0, PM_STATE=11b, VAUXDET=X, PWRGOOD=1). Refer to [Section 3.7.5, "Resets," on page 79](#) to for more information on this reset.
- D3_{HOT} to G3 (T12): This transition occurs when all power supplies are turned off (PCInRST=X, PM_STATE=XXb, VAUXDET=1 to 0, PWRGOOD=1 to 0). For example, total power failure.

3.7.4.5 The D3_{COLD} State

LAN9420/LAN9420i's behavior in this state is dependant on the status of VAUXDET. When VAUXDET=0, LAN9420/LAN9420i is powered from the system's +3.3V supply; wake from D3_{COLD} is disabled and the PCI +3.3V power supply is off. Since VAUXDET=0, the device is powered from the system's +3.3V power supply and LAN9420/LAN9420i loses all power and context (to LAN9420/LAN9420i, this appears identical to the G3 state).

When VAUXDET=1, LAN9420/LAN9420i is powered from the auxiliary power supply and the auxiliary 3.3Vaux supply remains operational. The device is isolated from the PCI bus and ignores all PCI accesses, as well as PCInRST. If the [PME Enable \(PME_EN\)](#) bit in the [PCI Power Management Control and Status Register \(PCI_PMCSR\)](#) is set, it is assumed that the device is configured to detect a wake event from D3_{COLD}. In this state the PCI 3.3Vaux power is on, but normal Ethernet receive and transmit operation is disabled. In D3_{COLD} power is reduced by disabling the internal PLL and derivative clocks.

3.7.4.5.1 POWER MANAGEMENT EVENTS IN D3_{COLD}

If configured to do so, the device is capable of detecting MAC (WOL, Magic Packet) and PHY (link status change) wake events and is capable of asserting nPME as a result of detection. In order to generate nPME in the D3_{COLD} state, LAN9420/LAN9420i must be powered from the 3.3Vaux power supply.

3.7.4.5.2 EXITING THE D3_{COLD} STATE

The device will exit the D3_{COLD} state under the following conditions. State transitions are illustrated in [Figure 3.28 on page 76](#).

- D3_{COLD} to D0_U (T9): This transition occurs when the +3.3V power supply is turned on. If VAUXDET = 1, this means that the 3.3Vaux supply was active and PCI power is now turned on (PCInRST=1 to 0, PM_STATE=11b, VAUXDET=1, PWRGOOD=0 to 1). In this case the entire device is reset, with the exception of the PCI PME context, which is preserved. The internal PHY is reset and is configured for all capable operation with auto negotiation enabled.
- If VAUXDET = 0, the device is seeing power for the first time and the internal power-on reset (POR) is asserted (PCInRST=1 to 0, PM_STATE=X, VAUXDET=0, PWRGOOD=0 to 1). All logic and registers are reset and the internal PHY is configured for all capable operation with auto negotiation enabled.
- D3_{COLD} to G3 (T12): This transition occurs when all power supplies are turned off (PCInRST=X, PM_STATE=XXb, VAUXDET=1 to 0, PWRGOOD=1 to 0). For example, total power failure.

3.7.5 Resets

The LAN9420/LAN9420i device employs the following resets:

- Power-On Reset (POR): This reset is asserted on initial application of device power. If the device is powered from the PCI auxiliary power supply, this reset is asserted for approximately 21mS after 3.3Vaux has reached its operational level. If the device is not powered from the auxiliary supply, this reset is asserted for approximately 21mS after the main PCI 3.3V supply has reached its operational level.
- PCInRST: This is the active-low reset input from the PCI bus. In the D0_U or D0_A states, the device is reset when PCInRST is low. In the D3_{HOT} or D3_{COLD} states, the device is reset on the deassertion (low-to-high transition) of PCInRST.
- D3 Transition Reset (D3RST): This reset occurs when transitioning from the D3_{HOT} to D0_U states.

- Software Reset (SRST): This reset is initiated by setting the [Software Reset \(SRST\)](#) bit in the [Bus Mode Register \(BUS_MODE\)](#). Software Reset does not clear control register bits marked as NASR.
- PHY Reset via PMT_CTRL (PHY_RST): This reset is asserted by setting the [PHY Reset \(PHY_RST\)](#) in the [Power Management Control Register \(PMT_CTRL\)](#). Refer to section [Section 3.6.9.1, "PHY Soft Reset via PMT_CTRL bit 10 \(PHY_RST\),"](#) on page 74 for more information.
- PHY Soft Reset (PHY_SRST): This reset is asserted by writing a '1' to bit 15 of the PHY's Basic Control Register. Refer to section [Section 3.6.9.2, "PHY Soft Reset via PHY Basic Control Register bit 15 \(PHY Reg. 0.15\),"](#) on page 74 for more information.

The reset map in [Table 3.22](#) shows the conditions under which various modules within LAN9420/LAN9420i are reset.

Table 3.22 Reset Map

BLOCK	POR	PCInRST	D3RST	SRST	PHY_RST	PHY_SRST
PCI PME Logic	X	Note 3.6				
PHY (Note 3.11)	X	X	Note 3.8		X	X (Note 3.10)
EEPROM Load	X	X				
PCI Configuration Registers (except PME registers)	X	X	X (Note 3.9)			
MAC	X	X	X	X		
TX/RX DMACS	X	X	X	X		
SCSR	X	X	X	X (Note 3.7)		

Note 3.6 PME logic is reset by PCInRST if LAN9420/LAN9420i is not configured to support D3_{COLD} wake; PME logic is not reset by PCInRST if LAN9420/LAN9420i is configured to support D3_{COLD} wake.

Note 3.7 Software Reset does not clear control register bits marked as NASR.

Note 3.8 If PHY was reset on entry to the D3_{HOT}, it will be reset when exiting the D3_{HOT}. If the PHY was not reset on entry to the D3_{HOT}, it will not be reset when exiting D3_{HOT}.

Note 3.9 The [Subsystem Vendor ID \(SSVID\)](#) [Subsystem Device ID \(SSID\)](#) registers (optionally loaded from the EEPROM) are not reset during this transition.

Note 3.10 PHY register bits designated as NASR are not initialized by setting the [PHY Soft Reset](#) bit in the PHY's [Basic Control Register](#).

Note 3.11 PHY reset conditions and mode settings are discussed in [Section 3.7.5.1, "PHY Resets,"](#) on page 80

3.7.5.1 PHY Resets

In addition to the PHY_RST, PHY_SRST and PCInRST noted in [Table 3.22](#), the PHY may also be reset on specific state transitions depending on the state of the VAUXDET signal and [PME Enable \(PME_EN\)](#) bit in the [PCI Power Management Control and Status Register \(PCI_PMCSR\)](#). Resets may leave the PHY in normal operating mode (all-capable with auto-negotiation enabled) or in the General Power-Down mode. Specific PHY reset conditions and the state of the PHY following reset, are

detailed in [Table 3.23](#) below. The state transitions noted in this table refer to those specified in [Section 3.7.4, "Power States,"](#) on page 76.

Table 3.23 PHY Resets

CONDITION	VAUXDET	PME_EN	MODE
T9	0	X	Normal
T6	1	X	General Power-Down
T1, T3	X	0	General Power-Down
T10, T11	1	0	General Power-Down
T5 (D3RST)	X	0	Normal

3.7.6 Detecting Power Management Events

LAN9420/LAN9420i supports the ability to generate PCI wake events using nPME on detection of a Magic Packet, Wakeup Frame or Ethernet link status change (energy detect). A simplified diagram of the wake event detection logic is shown in [Figure 3.29](#).

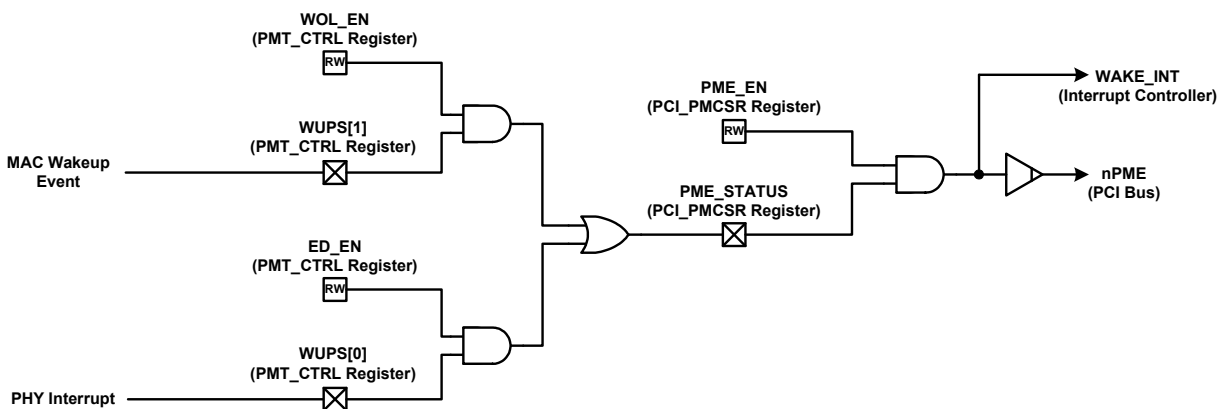

Figure 3.29 Wake Event Detection Block Diagram

Two control bits are implemented in the PMT_CTRL SCSR: Wake-on-LAN enable (WOL_EN) and Energy Detect enable (ED_EN). Depending on the state of these control bits, the logic will generate an internal wake event interrupt when the MAC detects a wakeup event (Wakeup Frame or Magic Packet), or a PHY interrupt is asserted (energy detect). Two [Wakeup Status \(WUPS\)](#) are implemented in the SCSR space. These bits are set depending on the corresponding wake event. (See [Section 4.2.9, "Power Management Control Register \(PMT_CTRL\),"](#) on page 98 for further information)

Wakeup Frame detection must be enabled in the MAC before detection can occur. Likewise, the energy detect interrupt must be enabled in the PHY before this interrupt can be used as a wake event. If LAN9420/LAN9420i is properly configured, the internal wake event interrupt will cause the assertion of the nPME signal on detection of a wake event.

When the device is in the D0_A state, wake event detection can also trigger the assertion of a PCI interrupt (nINT). Upon detection of the wake event, the wake logic sets the [Wake Event Interrupt](#)

(WAKE_INT) status bit in the [Interrupt Status Register \(INT_STS\)](#). If so enabled, setting this status bit will cause the assertion of nINT.

3.7.6.1 Enabling Wakeup Frame Wake Events

The Host system must perform the following steps to enable LAN9420/LAN9420i to assert a PCI wake event (nPME) on detection of a Wakeup frame.

1. All transmit and receive operations must be halted:
 - a. All pending Ethernet TX and RX operations must be completed, and then the DMA controller and MAC must be halted.
 - b. The software application must wait for all pending DMA transactions to complete. Upon completion, no further transactions are permitted.
2. The MAC must be configured to detect the desired wake event. This process is explained in [Section 3.5.4, "Wakeup Frame Detection," on page 57](#).
3. Bit 1 of the Wakeup Status (WUPS[1]) in the [Power Management Control Register \(PMT_CTRL\)](#) must be cleared since a set bit will cause the immediate assertion of wake event when WOL_EN is set. The WUPS[1] bit will not clear if the internal MAC wakeup event is asserted.
4. Set the [Wake-On-Lan Wakeup Enable \(WOL_EN\)](#) bit in the [Power Management Control Register \(PMT_CTRL\)](#).
5. Set the [PME Enable \(PME_EN\)](#) bit in the [PCI Power Management Control and Status Register \(PCI_PMCSR\)](#). Note that PME_EN must be set before entering the D3 state. If this bit is not set, the internal PHY will be reset and placed in the General Power-Down state and the device will not be able to detect wakeup frames.
6. To place the device in the D3 state, set the [Power Management State \(PM_STATE\)](#) field of the [PCI Power Management Control and Status Register \(PCI_PMCSR\)](#) to 11b ('D3' state). The device will enter D3_{HOT}. Device behavior in this state is described in [Section 3.7.4.4, "The D3HOT State," on page 78](#).

On detection of an enabled wakeup frame, the device will assert the nPME signal. The nPME signal will remain asserted until the [PME Enable \(PME_EN\)](#) and/or the [PME Status \(PME_STATUS\)](#) bits are cleared by the Host.

Note: If waking from a reduced-power state causes the assertion of a device reset, bit 4 of the [Power Management Control Register \(PMT_CTRL\)](#) register (WUPS[1]) will be cleared.

3.7.7 Enabling Link Status Change (Energy Detect) Wake Events

The Host system must perform the following steps to enable LAN9420/LAN9420i to assert a PCI wake event (nPME) on detection of an Ethernet link status change.

1. All transmit and receive operations must be halted:
 - a. All pending Ethernet TX and RX operations must be completed, and then the DMA controller and MAC must be halted.
 - b. The software application must wait for all pending DMA transactions to complete. Upon completion, no further transactions are permitted.
2. The ENERGYON event must be enabled as a PHY interrupt source. This is done by setting bit 7 in the PHY's [Interrupt Mask](#) register.
3. The PHY must be enabled for the energy detect power down mode. This is done by setting the [EDPWRDOWN](#) bit in the PHY's [Mode Control/Status](#) register. Enabling the energy detect power-down mode places the PHY in a reduced power state. In this mode of operation the PHY is not capable of receiving or transmitting Ethernet data. In this state the PHY will assert its internal interrupt if it detects Ethernet activity. Refer to [Section 3.6.8.2, "Energy Detect Power-Down," on page 74](#) for more information.

**Datasheet**

4. Bit 0 of the Wakeup Status (WUPS[0]) in the [Power Management Control Register \(PMT_CTRL\)](#) must be cleared since a set bit will cause the immediate assertion of wake event when ED_EN is set. The WUPS[0] bit will not clear if the internal PHY interrupt is asserted.
5. Set the [Energy-Detect Wakeup Enable \(ED_EN\)](#) bit in the [Power Management Control Register \(PMT_CTRL\)](#).
6. Set the [PME Enable \(PME_EN\)](#) bit in the [PCI Power Management Control and Status Register \(PCI_PMCSR\)](#). Note that PME_EN must be set before entering the D3 state. If this bit is not set, the internal PHY will be reset and placed in the General Power-Down state and the device will not be able to detect an Ethernet link status change.
7. If the device is to be placed in the D3 state, set the [Power Management State \(PM_STATE\)](#) field of the [PCI Power Management Control and Status Register \(PCI_PMCSR\)](#) to 11b ('D3' state). The device will enter D3_{HOT}. Device behavior in this state is described in [Section 3.7.4.4, "The D3HOT State," on page 78](#).

On detection of Ethernet activity (energy), the device will assert the nPME signal. The nPME signal will remain asserted until the [PME Enable \(PME_EN\)](#) and/or the [PME Status \(PME_STATUS\)](#) bits are cleared by the Host.

Chapter 4 Register Descriptions

The registers are partitioned into five groups. The first group is the System Control and Status Registers (SCSR). The second group is the DMA Control and Status Registers (DCSR). These registers are located within the DMAC and are used to control DMA-specific functions. The third group is the MAC Control and Status Registers (MCSR). These registers handle all control and status directly related to MAC function and are located within the MAC. The fourth group are the PHY control registers. These registers reside within the PHY, and are accessed indirectly through MCSR within the MAC. The fifth set of registers is the PCI Configuration Space CSR (CONFIG CSR) registers. Each group is described separately within this section.

[Figure 4.1](#) illustrates the memory map for the first three register groups. The Base Address (BA) of the map is determined by BAR3/BAR4, contained within the standard PCI Header Registers of the CONFIG CSR. See [Table 4.10, “Standard PCI Header Registers Supported,” on page 151](#) for details. In the case of BAR3, BA may be either the address of the lower (for little endian access) or upper (for big endian access) 512 byte segment of the 1KB MemSpace. See [Figure 3.3 CSR Double Endian Mapping on page 27](#) for details.

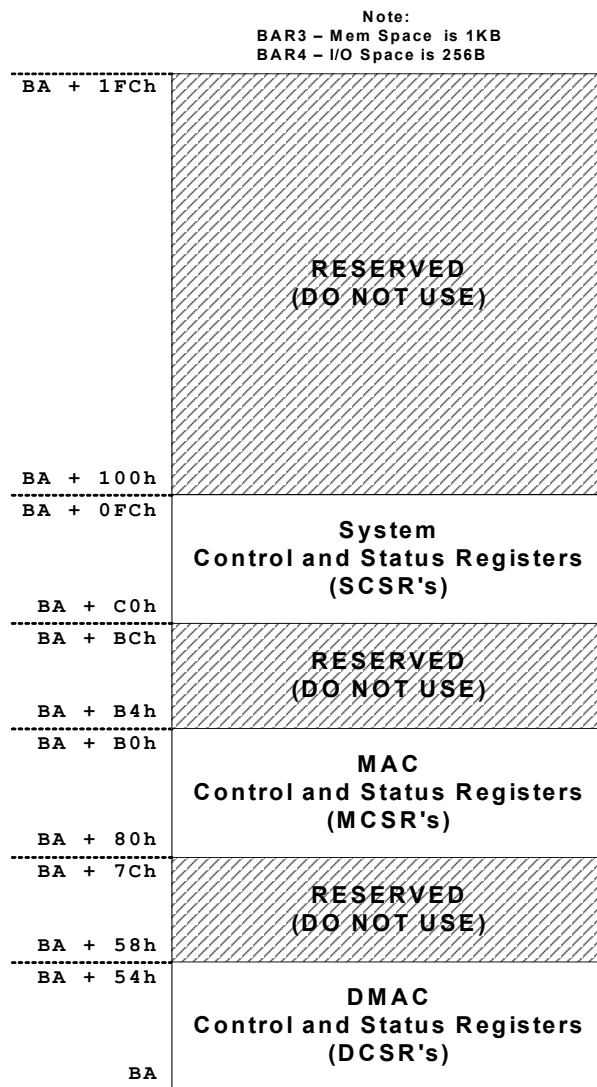

Figure 4.1 LAN9420/LAN9420i CSR Memory Map

4.1 Register Nomenclature

Table 4.1 describes the register bit attributes used throughout this section.

Table 4.1 Register Bit Types

REGISTER BIT TYPE NOTATION	REGISTER BIT DESCRIPTION
R	Read: A register or bit with this attribute can be read.
W	Write: A register or bit with this attribute can be written.
RO	Read only: Read only. Writes have no effect.
WO	Write only: If a register or bit is write-only, reads will return unspecified data.
WC	Write One to Clear: writing a one clears the value. Writing a zero has no effect
RC	Read to Clear: Contents is cleared after the read. Writes have no effect.
LL	Latch Low: This mode is used by the Ethernet PHY registers. Bits with this attribute will stay low until the bit is read. After a read, the bit will remain low, but will change to high if the condition that caused the bit to go low is removed. If the bit has not been read the bit will remain low regardless of if its cause has been removed.
LH	Latch High: This mode is used by the Ethernet PHY registers. Bits with this attribute will stay high until the bit is read. After a read, the bit will remain high, but will change to low if the condition that caused the bit to go high is removed. If the bit has not been read the bit will remain high regardless of if its cause has been removed.
SC	Self-Clearing: Contents is self-cleared after the being set. Writes of zero have no effect. Contents can be read.
NASR	Not Affected by Software Reset. The state of NASR bits does not change on assertion of a software reset.
RESERVED	<p>Reserved Field: Certain bits within registers are listed as “RESERVED”. Unless stated otherwise, these bits must be written with zero for future compatibility. The values of these bits are not guaranteed when read.</p> <p>Reserved Address: Certain addresses with the device are listed as “RESERVED”. Unless otherwise noted, do not read from or write to reserved addresses.</p>

Register attribute examples:

- **R/W:** Can be written. Will return current setting on a read.
- **R/WC:** Will return current setting on a read. Writing a one clears the bit.

4.2 System Control and Status Registers (SCSR)

Table 4.2, "System Control and Status Register Addresses" lists the registers contained in this section.

Table 4.2 System Control and Status Register Addresses

OFFSET	SYMBOL	REGISTER NAME
00C0h	ID_REV	ID and Block Revision
00C4h	INT_CTL	Interrupt Control Register
00C8h	INT_STS	Interrupt Status Register
00CCh	INT_CFG	Interrupt Configuration Register
00D0h	GPIO_CFG	General Purpose IO Configuration
00D4h	GPT_CFG	General Purpose Timer Configuration
00D8h	GPT_CNT	General Purpose Timer Current Count
00DCh	BUS_CFG	System Bus Configuration Register
00E0h	PMT_CTRL	Power Management Control
00E4h – 00F0h	RESERVED	Reserved for Future Use
00F4h	FREE_RUN	Free Run Counter
00F8h	E2P_CMD	EEPROM Command Register
00FCh	E2P_DATA	EEPROM Data Register
The registers located at 0100h - 01FCh are visible via the memory map, but are reserved and must not be accessed. The registers located at 0100h - 01FCh are not visible or accessible via IO.		
0100h – 01FCh	RESERVED	Reserved for Future Use

4.2.1 ID and Revision (ID_REV)

Offset: 00C0h Size: 32 bits

This register contains the device ID and block revision.

BITS	DESCRIPTION	TYPE	DEFAULT
31:16	Chip ID. This 16-bit field is used to identify the device model.	RO	9420h
15:0	Block Revision. This 16-bit field is used to identify the revision of the Ethernet Subsystem.	RO	Note 4.1

Note 4.1 Default value is dependent on device revision.

4.2.2 Interrupt Control Register (INT_CTL)

Offset: 00C4h Size: 32 bits

Interrupts are enabled/disabled through this register. Refer to [Section 3.3.1, "Interrupt Controller,"](#) on [page 28](#) for more information on the Interrupt Controller.

Note: The DMAC interrupt (DMAC_INT) is enabled through the DCSR.

BITS	DESCRIPTION	TYPE	DEFAULT
31:16	RESERVED	RO	-
15	Software Interrupt Enable (SW_INT_EN) On a transition from low to high, this register bit triggers the software interrupt.	R/W	0b
14	RESERVED	RO	-
13	Master Bus Error Interrupt Enable (MBERR_INT_EN) When set high, the Master Bus Error is enabled to generate an interrupt.	R/W	0b
12	Slave Bus Error Interrupt Enable (SBERR_INT_EN) When set high, the Slave Bus Error is enabled to generate an interrupt.	R/W	0b
11:7	RESERVED	RO	-
6:4	GPIO [2:0] (GPIOx_INT_EN) When set high the GPIOx are enabled as interrupt sources.	R/W	000b
3	GP Timer Interrupt Enable (GPT_INT_EN) When set high the General Purpose Timer is enabled as an interrupt source.	R/W	0b
2	PHY Interrupt Enable (PHY_INT_EN) When set high, the PHY interrupt is enabled as an interrupt source.	R/W	0b
1	Wake Event Interrupt Enable (WAKE_INT_EN) When set high, wake event detection is enabled as an interrupt source.	R/W	0b
0	RESERVED	RO	-

4.2.3 Interrupt Status Register (INT_STS)

Offset: 00C8h Size: 32 bits

This register contains the current status of the generated interrupts. Some of these interrupts are also cleared through this register.

BITS	DESCRIPTION	TYPE	DEFAULT
31:16	RESERVED	RO	-
15	Software Interrupt (SW_INT) This bit latches high upon the SW_INT_EN bit toggling from a 0 to 1. The interrupt is cleared by writing a '1'. Writing '0' has no effect.	R/WC	0b
14	RESERVED	RO	-
13	Master Bus Error Interrupt (MBERR_INT) When set, indicates DMA Controller has detected an error during descriptor read, or during a transmit data read operation. The interrupt is cleared by writing a '1' to this bit. Writing a '0' has no effect. To guarantee a clean recovery from a MBERR_INT condition, a software reset must be performed by setting the Software Reset (SRST) bit of the Bus Mode Register (BUS_MODE) . Alternatively, the condition may be cleared by a hardware reset.	R/WC	0b
12	Slave Bus Error Interrupt (SBERR_INT) When set, indicates that the PCI Target Interface has detected an error when the Host attempted to access the LAN9420/LAN9420i CSR. The interrupt is cleared by writing a '1' to this bit. Writing a '0' has no effect. To guarantee a clean recovery from a SBERR_INT condition, a software reset must be performed by setting the Software Reset (SRST) bit of the Bus Mode Register (BUS_MODE) . Alternatively, the condition may be cleared by a hardware reset.	R/WC	0b
11:7	RESERVED	RO	-
6:4	GPIO [2:0] (GPIOx_INT) Interrupts are generated from the GPIO's. These interrupts are configured through the GPIO_CFG register. Refer to 4.2.5, "General Purpose Input/Output Configuration Register (GPIO_CFG)," on page 93 for more information. These interrupts are cleared by writing a '1' to the corresponding bits. Writing '0' has no effect.	R/WC	000b
3	GP Timer (GPT_INT) This interrupt is issued when the General Purpose Timer wraps from maximum count to zero. This interrupt is cleared by writing a '1' to this bit. Writing '0' has no effect.	R/WC	0b
2	PHY Interrupt (PHY_INT) Indicates assertion of the PHY Interrupt. The PHY interrupt is cleared by clearing the interrupt source in the PHY Interrupt Status Register. Refer to Section 4.5.11, "Interrupt Source Flag," on page 147 for more information on this interrupt. Writing to this bit has no effect.	RO	0b

Datasheet

BITS	DESCRIPTION	TYPE	DEFAULT
1	Wake Event Interrupt (WAKE_INT) Indicates a valid MAC wakeup event (Wakeup Frame or Magic Packet) or PHY interrupt (Energy-Detect) has been received. The particular source of the interrupt can be determined by the WUPS field of the Power Management Control Register (PMT_CTRL) . Both WUPS bits must be cleared in order to clear WAKE_INT. Writing to the WAKE_INT bit has no effect.	RO	0b
0	DMAC Interrupt (DMAC_INT) This interrupt is generated by the DMA controller. This bit is read-only. The DMA interrupt is cleared by clearing the interrupt source in the DMAC_STATUS DCSR. Writing to this bit has no effect.	RO	0b

4.2.4 Interrupt Configuration Register (INT_CFG)

Offset: 00CCh Size: 32 bits

This register configures and monitors the interrupt (IRQ) signal.

Control of the de-assertion interval for the IRQ is also included. The de-assertion interval is the minimum time the IRQ will remain de-asserted after it has been asserted and cleared. After this time period has elapsed, the IRQ will be asserted if the interrupt is active. This interval begins counting when interrupt sources have been cleared from the asserted state. Refer to [Section 3.3.1, "Interrupt Controller,"](#) on page 28 for more information on the Interrupt Controller.

BITS	DESCRIPTION	TYPE	DEFAULT
31:20	RESERVED	RO	-
19	Master Interrupt (IRQ_INT) This read-only bit indicates the state of the IRQ line. When set high, one of the enabled interrupts is currently active. This bit will respond to the associated interrupts regardless of the IRQ_EN field. This bit is not affected by the setting of the INT_DEAS field.	RO	0b
18	IRQ Enable (IRQ_EN) When cleared, the IRQ output to the PCIB is disabled and will be permanently de-asserted. When set, the IRQ output functions normally.	R/W	0b
17:10	RESERVED	RO	-
9	Interrupt De-assertion Interval Clear (INT_DEAS_CLR) Writing a one to this register clears the de-assertion counter in the Interrupt Controller, thus causing a new de-assertion interval to begin (regardless of whether or not the Interrupt Controller is currently in an active de-assertion interval).	R/W/SC	0b
8	Interrupt De-assertion Status (INT_DEAS_STS) When set, this bit indicates that the INT_DEAS is currently in a de-assertion interval, and any interrupts (as indicated by the IRQ_INT and INT_EN bits) will not be delivered to the IRQ. When cleared, the INT_DEAS is currently not in a de-assertion interval, and enabled interrupts will be delivered to the IRQ.	RO	0b
7:0	Interrupt De-assertion Interval (INT_DEAS) This field determines the interrupt de-assertion interval for the IRQ in multiples of 10 microseconds. Writing zeros to this field disables the INT_DEAS interval and resets the interval counter. Any pending interrupts are then issued. If a new, non-zero value is written to the INT_DEAS field, any subsequent interrupts will obey the new setting. Note: The interrupt de-assertion interval does not apply to the wake interrupt.	R/W	00h

4.2.5 General Purpose Input/Output Configuration Register (GPIO_CFG)

Offset: 00D0h Size: 32 bits

This register configures the GPIO and LED functions.

BITS	DESCRIPTION	TYPE	DEFAULT
31	RESERVED	RO	-
30:28	<p>LED[3:1] enable (LEDx_EN) A '1' sets the associated pin as an LED output. When cleared low, the pin functions as a GPIO signal. Bits are assigned as follows:</p> <p>LED1/GPIO0 - bit 28 LED2/GPIO1 - bit 29 LED3/GPIO2 - bit 30</p>	R/W	000b
27	RESERVED	RO	-
26:24	<p>GPIO Interrupt Polarity 0-2 (GPIO_INT_POL) When set high, a high logic level on the corresponding GPIO pin will set the corresponding INT_STS register bit. When cleared low, a low logic level on the corresponding GPIO pin will set the corresponding INT_STS register bit. GPIO interrupts must also be enabled in GPIOx_INT_EN in the INT_EN register. Bits are assigned as follows:</p> <p>GPIO0 - bit 24 GPIO1 - bit 25 GPIO2 - bit 26</p> <p>Note: GPIO inputs must be active for greater than 80ns to be recognized as interrupt inputs.</p>	R/W	000b
23	RESERVED	RO	-
22:20	<p>EEPROM Enable (EEDPR_EN) The value of this field determines the function of the external EEDIO and EECLK. Please refer to Table 4.3, "EEPROM Enable Bit Definitions," on page 94 for the EEPROM Enable bit function definitions.</p> <p>Note: The Host must not change the function of the EEDIO and EECLK pins when an EEPROM read or write cycle is in progress. Do not use reserved setting.</p>	R/W	000b
19	RESERVED	RO	-
18:16	<p>GPIO Buffer Type 0-2 (GPIOBUF_n) When set, the output buffer for the corresponding GPIO signal is configured as a push/pull driver. When cleared, the corresponding GPIO set configured as an open-drain driver. Bits are assigned as follows:</p> <p>GPIO0 – bit 16 GPIO1 – bit 17 GPIO2 – bit 18</p>	R/W	000b
15:11	RESERVED	RO	-

BITS	DESCRIPTION	TYPE	DEFAULT
10:8	GPIO Direction 0-2 (GPDIRn) When set, enables the corresponding GPIO as an output. When cleared the GPIO is enabled as an input. Bits are assigned as follows: GPIO0 – bit 8 GPIO1 – bit 9 GPIO2 – bit 10	R/W	000b
7:5	RESERVED	RO	-
4:3	GPO Data 3-4 (GPODn) The value written is reflected on GPOn. Bits are assigned as follows: GPO3 – bit 3 GPO4 – bit 4	R/W	00b
2:0	GPIO Data 0-2 (GPIODn) When enabled as an output, the value written is reflected on GPION. When read, GPION reflects the current state of the corresponding GPIO pin. Bits are assigned as follows: GPIO0 – bit 0 GPIO1 – bit 1 GPIO2 – bit 2	R/W	Note 4.2

Note 4.2 Default value is dependent on the state of the GPIO pin.

Table 4.3 EEPROM Enable Bit Definitions

[22]	[21]	[20]	EEDIO FUNCTION	EECLK FUNCTION
0	0	0	EEDIO	EECLK
0	0	1	GPO3	GPO4
0	1	0	Reserved	
0	1	1	GPO3	RX_DV
1	0	0	Reserved	
1	0	1	TX_EN	GPO4
1	1	0	TX_EN	RX_DV
1	1	1	TX_CLK	RX_CLK

4.2.6 General Purpose Timer Configuration Register (GPT_CFG)

Offset: 00D4h Size: 32 bits

This register configures the general purpose timer (GPT). The GPT can be configured to generate interrupts at intervals defined in this register. Refer to [Section 3.3.3, "General Purpose Timer \(GPT\)," on page 30](#) for more information on the General Purpose Timer.

BITS	DESCRIPTION	TYPE	DEFAULT
31:30	RESERVED	RO	-
29	General Purpose Timer Enable (TIMER_EN) When a one is written to this bit the GPT is put into the run state. When cleared, the GPT is halted. On the 1-to-0 transition of this bit the GPT_LOAD field will be preset to FFFFh.	R/W	0b
28:16	RESERVED	RO	-
15:0	General Purpose Timer Pre-Load (GPT_LOAD) This value is pre-loaded into the GPT. See Section 3.3.3, "General Purpose Timer (GPT)," on page 30 for more details.	R/W	FFFFh

4.2.7 General Purpose Timer Current Count Register (GPT_CNT)

Offset: 00D8h Size: 32 bits

This register reflects the current value of the general purpose timer.

BITS	DESCRIPTION	TYPE	DEFAULT
31:16	RESERVED	RO	-
15:0	General Purpose Timer Current Count (GPT_CNT) This 16-bit field reflects the current value of the GPT.	RO	FFFFh

4.2.8 Bus Master Bridge Configuration Register (BUS_CFG)

Offset: 00DCh Size: 32 bits

This register determines the bus arbitration characteristics for the RX and TX DMA engines.

BITS	DESCRIPTION	TYPE	DEFAULT										
31:28	RESERVED	RO	-										
27	RESERVED	R/W	0b										
26:25	<p>RX/TX Arbitration Priority Select (CSR_RTXWEIGHT) This field selects the arbitration priority ratio for receive and transmit DMA operations. This field has no effect unless the BAR bit in the BUS_MODE DCSR is cleared.</p> <table> <thead> <tr> <th>Setting</th> <th>Priority Ratio (RX:TX)</th> </tr> </thead> <tbody> <tr> <td>00b</td> <td>1:1</td> </tr> <tr> <td>01b</td> <td>2:1</td> </tr> <tr> <td>10b</td> <td>3:1</td> </tr> <tr> <td>11b</td> <td>4:1</td> </tr> </tbody> </table>	Setting	Priority Ratio (RX:TX)	00b	1:1	01b	2:1	10b	3:1	11b	4:1	R/W	00b
Setting	Priority Ratio (RX:TX)												
00b	1:1												
01b	2:1												
10b	3:1												
11b	4:1												
24:0	RESERVED	RO	-										

4.2.9 Power Management Control Register (PMT_CTRL)

Offset: 00E0h Size: 32 bits

This register controls the wake event detection features. This register also controls the SCSR soft reset to the PHY.

Note: If waking from a reduced-power state causes the assertion of a device reset, this register will be cleared.

BITS	DESCRIPTION	TYPE	DEFAULT
31:11	RESERVED	RO	-
10	PHY Reset (PHY_RST) Writing a '1' to this bit resets the PHY. The internal logic automatically holds the PHY reset for a minimum of 100us. When the PHY is released from reset, this bit is automatically cleared. All writes to this bit are ignored while this bit is high.	SC	0b
9	Wake-On-Lan Wakeup Enable (WOL_EN) When set, the MAC Wake Detect signal is enabled as a wake event and will set the PME_STATUS in the PCI_PMCSR. The MAC Wake Detect signal can be programmed for assertion upon detection of a Wakeup Frame or Magic Packet.	R/W	0b
8	Energy-Detect Wakeup Enable (ED_EN) When set, the PHY Interrupt signal is enabled as a wake event and will set the PME_STATUS bit in the PCI_PMCSR. The PHY interrupt can be programmed for assertion upon detection of a link status change (Energy Detect) event.	R/W	0b
7:5	RESERVED	RO	-
4:3	Wakeup Status (WUPS) This field indicates the cause of the last wake event. This field is cleared by writing '1' to the currently set bit(s). WUPS is encoded as follows: 00b – No wakeup event detected x1b – PHY interrupt (Energy-Detect) 1xb – MAC wakeup event (Wakeup Frame or Magic Packet) Note: If waking from a reduced-power state causes the assertion of a device reset, the wakeup status bits will be cleared.	R/WC	00b
2:0	RESERVED	RO	000b

4.2.10 Free Run Counter (FREE_RUN)

Offset: 00F4h Size: 32 bits

This register reflects the value of the free-running (6.25Mhz) counter (FRC).

BITS	DESCRIPTION	TYPE	DEFAULT
31:0	Free Running Counter (FR_CNT) This field reflects the value of a free-running 32-bit counter. At reset, the counter starts at zero and is incremented for every 160ns cycle. When the maximum count has been reached the counter will rollover. Refer to Section 3.3.4, "Free-Run Counter (FRC)," on page 31 for more information on the FRC.	RO	-

4.2.11 EEPROM Command Register (E2P_CMD)

Offset: 00F8h Size: 32 bits

This register is used to control the read and write operations with the serial EEPROM.

BITS	DESCRIPTION	TYPE	DEFAULT
31	<p>EPC Busy (EPC_BSY) When a 1 is written into this bit, the operation specified in the EPC command field is performed at the specified EEPROM address. This bit will remain set until the operation is complete. In the case of a read this means that the Host can read valid data from the E2P data register. The E2P_CMD and E2P_DATA registers should not be modified until this bit is cleared. In the case where a write is attempted and an EEPROM is not present, the EPC Busy remains busy until the EPC Time-out occurs. At that time the busy bit is cleared.</p> <p>Note: EPC busy will be high immediately following power-up or reset. After the EEPROM controller has finished reading (or attempting to read) the MAC address and SSVID/SSID from the EEPROM, the EPC Busy bit is cleared.</p>	SC	0b

Datasheet

BITS	DESCRIPTION	TYPE	DEFAULT
30-28	<p>EPC Command (EPC_CMD) This field is used to issue commands to the EEPROM controller. The EPC will execute commands when the EPC Busy bit is set. A new command must not be issued until the previous command completes. This field is encoded as follows:</p> <p>[30:28] = 000; READ (Read Location): This command will cause a read of the EEPROM location pointed to by EPC Address. The result of the read is available in the E2P_DATA register.</p> <p>[30:28] = 001; EWDS (Erase/Write Disable): After issued, the EEPROM will ignore erase and write commands. To re-enable erase/write operations issue the EWEN command.</p> <p>[30:28] = 010; EWEN (Erase/Write Enable): Enables the EEPROM for erase and write operations. The EEPROM will allow erase and write operations until the Erase/Write Disable command is sent, or until power is cycled.</p> <p>Note: The EEPROM device will power-up in the erase/write-disabled state. Any erase or write operations will fail until an Erase/Write Enable command is issued.</p> <p>[30:28] = 011; WRITE (Write Location): If erase/write operations are enabled in the EEPROM, this command will cause the contents of the E2P_DATA register to be written to the EEPROM location selected by the EPC Address field.</p> <p>[30:28] = 100; WRAL (Write All): If erase/write operations are enabled in the EEPROM, this command will cause the contents of the E2P_DATA register to be written to every EEPROM memory location.</p> <p>[30:28] = 101; ERASE (Erase Location): If erase/write operations are enabled in the EEPROM, this command will erase the location selected by the EPC Address field.</p> <p>[30:28] = 110; ERAL (Erase All): If erase/write operations are enabled in the EEPROM, this command will initiate a bulk erase of the entire EEPROM.</p> <p>[30:28] = 111; RELOAD (EEPROM Reload): Instructs the EEPROM controller to reload the MAC address and SSVID/SSID from the EEPROM. If a value of 0xA5 is not found in the first address of the EEPROM, the EEPROM is assumed to be unprogrammed and EEPROM Reload operation will fail. The 'EEPROM Loaded' bit indicates a successful load of the MAC address and SSVID/SSID.</p>	R/W	000b
27:10	RESERVED	RO	-
9	<p>EPC Time-out (EPC_TO) If an EEPROM operation is performed, and there is no response from the EEPROM within 30mS, the EEPROM controller will timeout and return to its idle state. This bit is set when a time-out occurs indicating that the last operation was unsuccessful.</p> <p>Note: If the EEDIO signal pin is externally pulled-high, EPC commands will not time out if the EEPROM device is missing. In this case the EPC Busy bit will be cleared as soon as the command sequence is complete. It should also be noted that the ERASE, ERAL, WRITE and WRAL commands are the only EPC commands that will time-out if an EEPROM device is not present -and- the EEDIO signal is pulled low.</p>	R/WC	0b

BITS	DESCRIPTION	TYPE	DEFAULT
8	EEPROM Loaded When set, this bit indicates that a valid EEPROM was found, and that the MAC address and SSVID/SSID programming have completed normally. This bit is set after a successful load of the MAC address and SSVID/SSID after power-up, or after a RELOAD command has completed.	R/WC	0b
7:0	EPC Address (EPC_ADDR) The 8-bit value in this field is used by the EEPROM Controller to address the specific memory location in the Serial EEPROM. This is a Byte aligned address.	R/W	00h

4.2.12 EEPROM Data Register (E2P_DATA)

Offset: 00FCh Size: 32 bits

This register is used in conjunction with the E2P_CMD register to perform read and write operations with the serial EEPROM.

BITS	DESCRIPTION	TYPE	DEFAULT
31:8	RESERVED	RO	-
7:0	EEPROM Data Value read from or written to the EEPROM.	R/W	Note 4.3

Note 4.3 Following reset, the default value of the EEPROM Data reflects the last value read by the EEPROM controller during auto-loading, or the last value read during an attempt to auto-load the EEPROM contents.

4.3 DMAC Control and Status Registers (DCSR)

Table 4.4 lists the registers contained in this section.

Table 4.4 DMAC Control and Status Register (DCSR) Map

OFFSET	SYMBOL	REGISTER NAME
0000h	BUS_MODE	Bus Mode Register
0004h	TX_POLL_DEMAND	Transmit Poll Demand Register
0008h	RX_POLL_DEMAND	Receive Poll Demand Register
000Ch	RX_BASE_ADDR	Receive List Base Address Register
0010h	TX_BASE_ADDR	Transmit List Base Address Register
0014h	DMAC_STATUS	DMA Controller Status Register
0018h	DMAC_CONTROL	DMA Controller Control (Operation Mode) Register
001Ch	DMAC_INTR_ENA	DMA Controller Interrupt Enable Register
0020h	MISS_FRAME_CNTR	Missed Frame Counter (RX Only)
0024h – 004Ch	RESERVED	Reserved for future expansion
0050h	CUR_TX_BUF_ADDR	Current Transmit Buffer Address
0054h	CUR_RX_BUF_ADDR	Current Receive Buffer Address
0058h – 007Ch	RESERVED	Reserved for future expansion

4.3.1 Bus Mode Register (BUS_MODE)

Offset: 0000h Size: 32 bits

This register establishes the bus operating modes for the DMAC.

BITS	DESCRIPTION	TYPE	DEFAULT
31:21	RESERVED	RO	-
20	<p>Descriptor Byte Ordering (DBO) When set, the device operates in big-endian mode for descriptors. In big-endian mode descriptor byte lanes 0-3 and 1-2 are swapped. CSR bit positions within each byte are not changed.</p> <p>This bit should be cleared to '0' for normal operation.</p>	R/W	0b
19:14	RESERVED	RO	-
13:8	<p>Programmable Burst Length (PBL) Indicates the maximum number of DWORDs to be transferred in one DMA transaction. This will be the maximum value that is used in a single block read/write. The DMAC will always attempt to burst transfer the length specified in the PBL each time it starts a burst transfer.</p> <p>PBL can be programmed with permissible values of 1, 2, 4, 8, 16 and 32. Any other value will result in undefined behavior.</p> <p>Note: PCI bursts are always 16 cycles, regardless of the value in this field.</p>	R/W	001000b
7	<p>Big-Endian/Little-Endian (BLE) Specifies the byte ordering for data buffers. When set, the DMAC operates in big-endian mode when accessing data buffers in Host memory. In big-endian mode buffer byte lanes 0-3 and 1-2 are swapped.</p> <p>This bit should be cleared to '0' for normal operation.</p>	R/W	0b
6:2	<p>Descriptor Skip Length (DSL) Specifies the number of DWORDs to skip between two unchained descriptors.</p>	R/W	00000b
1	<p>Bus Arbitration (BAR) When this bit is set the RX DMA operations are given priority while guarantying TX at least one grant in between consecutive RX packets. When cleared, the arbitration ratio is dictated by the BUS_CFG[26:25] field.</p>	R/W	0b
0	<p>Software Reset (SRST) When this bit is set, the DMAC and MAC are reset. This is a self-clearing bit.</p> <p>Note: It will take up to 120ns for the SRST to complete</p>	R/W/SC	0b

4.3.2 Transmit Poll Demand Register (TX_POLL_DEMAND)

Offset: 0004h Size: 32 bits

This register enables the TX DMA engine to check for new descriptors.

BITS	DESCRIPTION	TYPE	DEFAULT
31:0	Transmit Poll Demand (TPD) When written with any value, the DMAC will check for frames to be transmitted. If no descriptor is available, the transmit process returns to the suspended state and bit 2 of the DMAC_STATUS register (transmit buffer unavailable - TU) is not asserted. A write to this register is only effective if the transmit process is in the suspended state. A Read of this register will timeout and invalid data will be returned.	WO	-

Datasheet

4.3.3 Receive Poll Demand Register (RX_POLL_DEMAND)

Offset: 0008h Size: 32 bits

This register enables the RX DMAC to check for new descriptors.

BITS	DESCRIPTION	TYPE	DEFAULT
31:0	Receive Poll Demand (RPD) When written with any value, the DMAC will check for receive descriptors. If no descriptors are available, the receive process returns to the suspended state and bit 7 of the DMAC_STATUS register (receive buffer unavailable - RU) is not set. A write to this register is only effective if the receive process is in the suspended state. A Read of this register will timeout and invalid data will be returned.	WO	-

4.3.4 Receive List Base Address Register (RX_BASE_ADDR)

Offset: 000Ch Size: 32 bits

This register specifies the start address of the receive buffer list. RX_BASE_ADDR must be 4-DWORD (16 byte) aligned (e.g. Reserved address bits 3:0 must be 0).

BITS	DESCRIPTION	TYPE	DEFAULT
31:4	Start of Receive List (SRL) This field points to the start of the receive buffer descriptor list. The descriptor list resides in the Host memory. Writing this register is only valid when the RX DMA engine is in the stopped state. When stopped, this register must be written before the START command is given.	R/W	28'h0
3:0	RESERVED	RO	-

4.3.5 Transmit List Base Address Register (TX_BASE_ADDR)

Offset: 0010h Size: 32 bits

This register specifies the start address of the transmit buffer list. TX_BASE_ADDR must be 4-DWORD (16 byte) aligned (e.g. Reserved address bits 3:0 must be 0).

BITS	DESCRIPTION	TYPE	DEFAULT
31:4	Start of Transmit List (STL) This field points to the start of the transmit buffer descriptor list. The descriptor list resides in the Host memory. Writing this register is only valid when the TX DMA engine is in the stopped state. When stopped, this register must be written before the START command is given.	R/W	28'h0
3:0	RESERVED	RO	-

4.3.6 DMA Controller Status Register (DMAC_STATUS)

Offset: 0014h Size: 32 bits

This register contains all of the status bits that the DMAC reports to the Host system. Most of the fields in this register will cause an interrupt. Status can be checked as part of an interrupt service routine, or by polling. DMAC interrupts can be masked in the DMAC_INTR_ENA register.

BITS	DESCRIPTION	TYPE	DEFAULT																		
31:23	RESERVED	RO	-																		
22:20	<p>Transmit Process State (TS) This Read-Only field indicates the state of the transmit process. This field does not generate an interrupt. The TS field is encoded as follows:</p> <table border="1"> <thead> <tr> <th>STATE</th> <th>DESCRIPTION</th> </tr> </thead> <tbody> <tr> <td>000</td> <td>Stopped - Reset or Stop command issued</td> </tr> <tr> <td>001</td> <td>Running - Fetching the transmit descriptor</td> </tr> <tr> <td>010</td> <td>Running - Waiting for the end of transmission</td> </tr> <tr> <td>011</td> <td>Running - Reading the data from memory and queuing into TX FIFO</td> </tr> <tr> <td>100</td> <td>RESERVED</td> </tr> <tr> <td>101</td> <td>RESERVED</td> </tr> <tr> <td>110</td> <td>Suspended - Unavailable transmit descriptor</td> </tr> <tr> <td>111</td> <td>Running - Closing the transmit descriptor</td> </tr> </tbody> </table>	STATE	DESCRIPTION	000	Stopped - Reset or Stop command issued	001	Running - Fetching the transmit descriptor	010	Running - Waiting for the end of transmission	011	Running - Reading the data from memory and queuing into TX FIFO	100	RESERVED	101	RESERVED	110	Suspended - Unavailable transmit descriptor	111	Running - Closing the transmit descriptor	RO	000b
STATE	DESCRIPTION																				
000	Stopped - Reset or Stop command issued																				
001	Running - Fetching the transmit descriptor																				
010	Running - Waiting for the end of transmission																				
011	Running - Reading the data from memory and queuing into TX FIFO																				
100	RESERVED																				
101	RESERVED																				
110	Suspended - Unavailable transmit descriptor																				
111	Running - Closing the transmit descriptor																				
19:17	<p>Receive Process State (RS) This Read-Only field indicates the state of the receive process. This field does not generate an interrupt. The RS field is encoded as follows:</p> <table border="1"> <thead> <tr> <th>STATE</th> <th>DESCRIPTION</th> </tr> </thead> <tbody> <tr> <td>000</td> <td>Stopped - Reset or Stop receive command</td> </tr> <tr> <td>001</td> <td>Running - Fetching the receive descriptor</td> </tr> <tr> <td>010</td> <td>Running - Checking for end of receive packet before prefetch of next descriptor</td> </tr> <tr> <td>011</td> <td>Running - Waiting for receive packet</td> </tr> <tr> <td>100</td> <td>Suspended - Unavailable receive descriptor</td> </tr> <tr> <td>101</td> <td>Running - Closing receive descriptor</td> </tr> <tr> <td>110</td> <td>Running - Flushing the current frame from the receive buffer because of unavailable receive buffer</td> </tr> <tr> <td>111</td> <td>Running - Queuing the receive frame from the receive buffer into the Host memory</td> </tr> </tbody> </table>	STATE	DESCRIPTION	000	Stopped - Reset or Stop receive command	001	Running - Fetching the receive descriptor	010	Running - Checking for end of receive packet before prefetch of next descriptor	011	Running - Waiting for receive packet	100	Suspended - Unavailable receive descriptor	101	Running - Closing receive descriptor	110	Running - Flushing the current frame from the receive buffer because of unavailable receive buffer	111	Running - Queuing the receive frame from the receive buffer into the Host memory	RO	000b
STATE	DESCRIPTION																				
000	Stopped - Reset or Stop receive command																				
001	Running - Fetching the receive descriptor																				
010	Running - Checking for end of receive packet before prefetch of next descriptor																				
011	Running - Waiting for receive packet																				
100	Suspended - Unavailable receive descriptor																				
101	Running - Closing receive descriptor																				
110	Running - Flushing the current frame from the receive buffer because of unavailable receive buffer																				
111	Running - Queuing the receive frame from the receive buffer into the Host memory																				
16	<p>Normal Interrupt Summary (NIS) This bit is the logical OR of other bits within this register. Only unmasked bits affect this register. Below is the list of bits: DMAC_STATUS[0]: Transmit interrupt (TI) DMAC_STATUS[2]: Transmit buffer unavailable (TU) DMAC_STATUS[6]: Receive interrupt (RI)</p>	R/WC	0b																		

Datasheet

BITS	DESCRIPTION	TYPE	DEFAULT
15	<p>Abnormal Interrupt Summary (AIS) This bit is the logical OR of other bits within this register. Only unmasked bits affect this register. Below is the list of bits:</p> <p>DMAC_STATUS[1]: Transmit process stopped (TPS) DMAC_STATUS[7]: Receive buffer unavailable (RU) DMAC_STATUS[8]: Receive process stopped (RPS)</p>	R/WC	0b
14:10	RESERVED	RO	-
9	<p>Receive Watchdog Timeout (RWT) A Receive Watchdog Timeout occurs when the length of the receiving frame is greater than 2048 bytes through 2560 bytes.</p>	R/WC	0b
8	<p>Receive Process Stopped (RPS) Asserted when the Receive process enters the stopped state.</p>	R/WC	0b
7	<p>Receive Buffer Unavailable (RU) Indicates that the next descriptor in the receive list is owned by the Host and cannot be acquired by the DMA Controller. The reception process is suspended. To resume processing receive descriptors, the Host should change the ownership of the descriptor and issue a receive poll demand command. If no receive poll demand is issued, the reception process resumes when the next recognized incoming frame is received.</p> <p>After the first assertion, RU is not asserted for any subsequent "not owned" receive descriptor fetches. RU is set only when the previous receive descriptor was owned by the DMA controller. RU remains asserted until it is cleared by software.</p>	R/WC	0b
6	<p>Receive Interrupt (RI) Indicates the completion of the frame reception. Specific frame status information has been posted in the descriptor. The reception process remains in the running state.</p>	R/WC	0b
5:3	RESERVED	RO	-
2	<p>Transmit Buffer Unavailable (TU) Indicates that the next descriptor in the Transmit list is owned by the Host system and cannot be acquired by the DMA Controller. The transmission process is suspended (bits [22:20]). To resume processing transmit descriptors, the Ownership bit in the descriptor should be set, indicating that the DMA Controller now owns the buffer and then a transmit poll demand command should be issued.</p>	R/WC	0b
1	<p>Transmit Process Stopped (TPS) Set when the transmit process enters the stopped state.</p>	R/WC	0b
0	<p>Transmit Interrupt (TI) Indicates that a frame transmission was completed and TDES1[31] is set in the first Descriptor indicating that the TX descriptor has been updated.</p>	R/WC	0b

4.3.7 DMA Controller Control (Operation Mode) Register (DMAC_CONTROL)

Offset: 0018h Size: 32 bits

This register establishes the RX and TX operating modes and commands. This should be the last DCSR written as part of initialization.

BITS	DESCRIPTION	TYPE	DEFAULT
31:23	RESERVED	RO	-
22	RESERVED	R/W	0b
21	Must Be One (MBO) This bit must be set to '1' for normal device operation.	R/W	0b
19:16	RESERVED	RO	-
15:14	RESERVED	R/W	00b
13	<p>Start/Stop Transmission Command (ST) When set, the transmission process is placed in the Running state, and the DMAC checks the transmit list at the current position for a frame to be transmitted.</p> <p>Descriptor acquisition is attempted either from the current position in the list, which is the transmit list base address set by TX_BASE_ADDR, or from the position retained when the transmit process was previously stopped. If no descriptor can be acquired, the transmit process enters the Suspended state. If the current descriptor is not owned by the DMA Controller, the transmission process enters the Suspended state and the Transmit Buffer Unavailable (DMAC_STATUS bit [2]) is set. The Start Transmission command is effective only when the transmission process is stopped. If the command is issued before setting the TX_BASE_ADDR, then the DMA Controller's behavior will be undefined.</p> <p>When reset, the transmission process is placed in the Stopped state after completing the transmission of the current frame. The next descriptor position in the transmit list is saved, and becomes the current position when transmission is restarted.</p> <p>The Stop Transmission command is effective only when the transmission process is in either Running or Suspended state.</p>	R/W	0b
12:3	RESERVED	RO	-
2	<p>Operate on Second Frame (OSF) When set, this bit instructs the DMA Controller to process a second frame of transmit data even before status for the first frame is obtained. This bit affects the DMA Controller but not the MIL.</p>	R/W	0b

Datasheet

BITS	DESCRIPTION	TYPE	DEFAULT
1	<p>Start/Stop Receive (SR) When set, the Receive Process is placed in the Running state. The DMA Controller attempts to acquire the descriptor from the receive list and process incoming frames.</p> <p>Descriptor acquisition is attempted from the current position in the list, which is the address set by the RX_BASE_ADDR or the position retained when the receive process was previously stopped. If no descriptor is owned by the DMA Controller, the Receive process enters the Suspended state and the Receive Buffer Unavailable (DMAC_STATUS bit [7]) is set.</p> <p>The Start Reception command is effective only when the reception process has stopped. If the command was issued before setting the RX_BASE_ADDR, the DMA Controller's behavior will be undefined. When cleared, the Receive process enters the Stopped state after completing the reception of the current frame. The next descriptor position in the receive list is saved, and becomes the current position after the Receive process is restarted. The Stop Reception command is effective only when the Receive process is in the Running or Suspended State.</p> <p>Note: In order to successfully enable the receive path, the RX DMAC must be enabled (by setting SR) prior to enabling the receiver (by setting the RXEN bit of the MAC Control Register (MAC_CR)).</p> <p>Note: In order to successfully disable the receive path, the receiver must be disabled (by clearing the RXEN bit of the MAC Control Register (MAC_CR)) prior to disabling the RX DMAC (by clearing SR). Otherwise, RX DMA will not stop (DMAC_STATUS will continue to show the Receive Process State (RS) as Running and Receive Process Stopped (RPS) does not assert).</p>	R/W	0b
0	RESERVED	RO	-

4.3.8 DMA Controller Interrupt Enable Register (DMAC_INTR_ENA)

Offset: 001Ch Size: 32 bits

This register enables the DMAC interrupts reported in the DMAC_STATUS register. Setting a bit to 1 enables the corresponding interrupt. After a hardware or software reset, all interrupts are disabled.

BITS	DESCRIPTION	TYPE	DEFAULT
31:17	RESERVED	RO	-
16	Normal Interrupt Summary Enable (NIS_EN) When set, normal interrupt is enabled. When reset, no normal interrupt is enabled. This bit enables the following bits: DMAC_STATUS[0]: Transmit interrupt (TI) DMAC_STATUS[2]: Transmit buffer unavailable (TU) DMAC_STATUS[6]: Receive interrupt (RI)	R/W	0b
15	Abnormal Interrupt Summary Enable (AIS_EN) When set, abnormal interrupt is enabled. When reset, no abnormal interrupt is enabled. This bit enables the following bits: DMAC_STATUS[1]: Transmit process stopped (TPS) DMAC_STATUS[5]: RESERVED DMAC_STATUS[7]: Receive buffer unavailable (RU) DMAC_STATUS[8]: Receive process stopped (RPS)	R/W	0b
14	RESERVED	R/W	0b
13:11	RESERVED	RO	-
10	RESERVED	R/W	0b
9	Receive Watchdog Timeout (RWT_EN) The Receive Watchdog Timeout is enabled only when this bit and the Abnormal Interrupt Summary Enable bit (bit [15]) are set.	R/W	0b
8	Receive Process Stopped (RPS_EN) The Receive Process Stopped Interrupt is enabled only when this bit and the Abnormal Interrupt Summary Enable bit (bit [15]) are set.	R/W	0b
7	Receive Buffer Unavailable (RU_EN) The Receive Buffer Unavailable Interrupt is enabled only when this bit and the Abnormal Interrupt Summary Enable bit (bit [15]) are set.	R/W	0b
6	Receive Interrupt (RI_EN) The Receive Interrupt is enabled only when this bit and the Abnormal Interrupt Summary Enable bit (bit [15]) are set.	R/W	0b
5	RESERVED	R/W	0b
4:3	RESERVED	RO	-
2	Transmit Buffer Unavailable (TU_EN) The Transmit Buffer Unavailable Interrupt is enabled only when this bit and the Normal Interrupt Summary Enable bit (bit [16]) are set.	R/W	0b

Datasheet

BITS	DESCRIPTION	TYPE	DEFAULT
1	Transmit Process Stopped (TPS_EN) The Transmit Process Stopped Interrupt is enabled only when this bit and the Abnormal Interrupt Summary Enable bit (bit [15]) are set.	R/W	0b
0	Transmit Interrupt (TI_EN) The Transmit Interrupt is enabled only when this bit and the Normal Interrupt Summary Enable bit (bit [16]) are set.	R/W	0b

4.3.9 Missed Frame and Buffer Overflow Counter Reg (MISS_FRAME_CNTR)

Offset: 0020h Size: 32 bits

The DMAC maintains two counters to track the number of missed frames during a receive operation. The MISS_FRAME_CNTR register reports the current value of these counters and their overflow bits.

BITS	DESCRIPTION	TYPE	DEFAULT
31:29	RESERVED	RO	-
28	MIL RX FIFO Full Counter Overflow (MIL_OVER) Overflow bit for the MIL_FIFO_FULL counter. This bit is automatically cleared on a read.	RC	0b
27:17	MIL RX FIFO Full Counter (MIL_FIFO_FULL) This field indicates the number of frames missed due a MIL RX FIFO full condition. This counter is automatically cleared on a read.	RC	000h
16	RX Buffer Unavailable Counter Overflow (UNAV_OVER) Overflow bit for the RX_BUFF_UNAV counter. This bit is automatically cleared on a read.	RC	0b
15:0	RX Buffer Unavailable Counter (RX_BUFF_UNAV) This field indicates the number of frames missed due to receive buffers being unavailable. This counter is incremented each time the DMAC discards an incoming frame. This counter is automatically cleared on a read.	RC	0000h

4.3.10 Current Transmit Buffer Address Register (TX_BUFF_ADDR)

Offset: 0050h Size: 32 bits

This register points to the current transmit buffer address being read by the DMAC.

BITS	DESCRIPTION	TYPE	DEFAULT
31:0	TX_BUFF_ADDR This field contains the pointer to the current buffer address pointer used by the DMAC during TX operation.	RO	32'h0

4.3.11 Current Receive Buffer Address Register (RX_BUFF_ADDR)

Offset: 0054h Size: 32 bits

This register points to the current receive buffer address being read by the DMAC.

BITS	DESCRIPTION	TYPE	DEFAULT
31:0	RX_BUFF_ADDR This field contains the pointer to the current buffer address pointer used by the DMAC during RX operation.	RO	32'h0

4.4 MAC Control and Status Registers (MCSR)

Table 4.5 lists the registers contained in this section.

Table 4.5 MAC Control and Status Register (MCSR) Map

OFFSET	SYMBOL	REGISTER NAME
0080h	MAC_CR	MAC Control
0084h	ADDRH	MAC Address High
0088h	ADDRL	MAC Address Low
008Ch	HASHH	Multicast Hash Table High
0090h	HASHL	Multicast Hash Table Low
0094h	MIIADDR	MII Address
0098h	MIIDATA	MII Data
009Ch	FLOW	Flow Control
00A0h	VLAN1	VLAN1 Tag
00A4h	VLAN2	VLAN2 Tag
00A8h	WUFF	Wakeup Frame Filter
00ACh	WUCSR	Wakeup Control and Status
00B0h	COE_CR	Checksum Offload Engine Control
00B4h - 00BCh	RESERVED	Reserved for future use

4.4.1 MAC Control Register (MAC_CR)

Offset: 0080h Size: 32 bits

This register establishes the RX and TX operating modes and includes controls for address filtering and packet filtering.

BITS	DESCRIPTION	TYPE	DEFAULT
31	Receive All Mode (RXALL) When set, all incoming packets will be received and passed on to the address filtering function for processing of the selected filtering mode on the received frame. Address filtering then occurs and is reported in Receive Status. When reset, only frames that pass Destination Address filtering will be sent to the Application.	R/W	0b
30-24	RESERVED	RO	-
23	Disable Receive Own (RCVOWN) When set, the MAC disables the reception of frames when TXEN is asserted. The MAC blocks the transmitted frame on the receive path. When reset, the MAC receives all packets the PHY gives, including those transmitted by the MAC. This bit should be reset when the Full Duplex Mode bit is set.	R/W	0b
22	RESERVED	RO	-
21	Loopback operation Mode (LOOPBK) Selects the loop back operation modes for the MAC. This is only for full duplex mode 0 - Normal. No feedback 1 - Internal through MII In internal loopback mode, the TX frame is received by the Internal MII interface, and sent back to the MAC without being sent to the PHY. Note: When enabling or disabling the loopback mode it can take up to 10 μ s for the mode change to occur. The transmitter and receiver must be stopped and disabled when modifying the LOOPBK bit. The transmitter or receiver should not be enabled within 10 μ s of modifying the LOOPBK bit.	R/W	0b
20	Full Duplex Mode (FDPX) When set, the MAC operates in Full-Duplex mode, in which it can transmit and receive simultaneously.	R/W	0b
19	Pass All Multicast (MCPAS) When set, indicates that all incoming frames with a Multicast destination address (first bit in the destination address field is 1) are received. Incoming frames with physical address (Individual Address/Unicast) destinations are filtered and received only if the address matches the MAC Address.	R/W	0b
18	Promiscuous Mode (PRMS) When set, indicates that any incoming frame is received regardless of its destination address.	R/W	1b
17	Inverse filtering (INVFILT) When set, the address check Function operates in Inverse filtering mode. This is valid only during Perfect filtering mode.	R/W	0b
16	Pass Bad Frames (PASSBAD) When set, all incoming frames that passed address filtering are received, including runt frames and collided frames.	R/W	0b

Datasheet

BITS	DESCRIPTION	TYPE	DEFAULT
15	Hash Only Filtering mode (HO) When set, the address check Function operates in the imperfect address filtering mode both for physical and multicast addresses	R/W	0b
14	RESERVED	RO	-
13	Hash/Perfect Filtering Mode (HPFILT) When reset (0), LAN9420/LAN9420i will implement a perfect address filter on incoming frames according the address specified in the MAC address register. When set (1), the address check function does imperfect address filtering of multicast incoming frames according to the hash table specified in the multicast hash table register. If the Hash Only Filtering mode (HO) bit is set (1), then the physical (IA) are imperfect filtered too. If the Hash Only Filtering mode (HO) bit is reset (0), then the IA addresses are perfect address filtered according to the MAC Address register.	R/W	0b
12	Late Collision Control (LCOLL) When set, enables retransmission of the collided frame even after the collision period (late collision). When reset, the MAC disables frame transmission on a late collision. In any case, the Late Collision status is appropriately updated in the Transmit Packet status.	R/W	0b
11	Disable Broadcast Frames (BCAST) When set, disables the reception of broadcast frames. When reset, forwards all broadcast frames to the application. Note: When wake-up frame detection is enabled via the WUEN bit of the WakeUp Control and Status Register (WUCSR) , a broadcast wake-up frame will wake-up the device despite the state of this bit.	R/W	0b
10	Disable Retry (DISRTY) When set, the MAC attempts only one transmission. When a collision is seen on the bus, the MAC ignores the current frame and goes to the next frame and a retry error is reported in the Transmit status. When reset, the MAC attempts 16 transmissions before signaling a retry error.	R/W	0b
9	RESERVED	RO	-
8	Automatic Pad Stripping (PADSTR) When set, the MAC strips the pad field on all incoming frames, if the length field is less than 46 bytes. The FCS field is also stripped, since it is computed at the transmitting station based on the data and pad field characters, and is invalid for a received frame that has had the pad characters stripped. Receive frames with a 46-byte or greater length field are passed to the Application unmodified (FCS is not stripped). When reset, the MAC passes all incoming frames to Host memory unmodified. Note: When PADSTR is enabled, the RX Checksum Offload Engine must be disabled (RX_COE_EN bit of the Checksum Offload Engine Control Register (COE_CR)) and vice versa. These functions cannot be enabled simultaneously.	R/W	0b

BITS	DESCRIPTION	TYPE	DEFAULT										
7-6	<p>BackOff Limit (BOLMT) The BOLMT bits allow the user to set its back-off limit in a relaxed or aggressive mode. According to IEEE 802.3, the MAC has to wait for a random number [r] of slot-times (Note 4.4) after it detects a collision, where: (eq.1) $0 < r < 2^K$ The exponent K is dependent on how many times the current frame to be transmitted has been retried, as follows: (eq.2) $K = \min(n, 10)$ where n is the current number of retries. If a frame has been retried three times, then K = 3 and r = 8 slot-times maximum. If it has been retried 12 times, then K = 10, and r = 1024 slot-times maximum. An LFSR (linear feedback shift register) 20-bit counter emulates a 20bit random number generator, from which r is obtained. Once a collision is detected, the number of the current retry of the current frame is used to obtain K (eq.2). This value of K translates into the number of bits to use from the LFSR counter. If the value of K is 3, the MAC takes the value in the first three bits of the LFSR counter and uses it to count down to zero on every slot-time. This effectively causes the MAC to wait eight slot-times. To give the user more flexibility, the BOLMT value forces the number of bits to be used from the LFSR counter to a predetermined value as in the table below.</p> <table border="1" data-bbox="358 835 1065 1060"> <thead> <tr> <th>BOLMT Value</th> <th># Bits Used from LFSR Counter</th> </tr> </thead> <tbody> <tr> <td>2'b00</td> <td>10</td> </tr> <tr> <td>2'b01</td> <td>8</td> </tr> <tr> <td>2'b10</td> <td>4</td> </tr> <tr> <td>2'b11</td> <td>1</td> </tr> </tbody> </table> <p>Thus, if the value of K = 10, the MAC will look at the BOLMT if it is 00, then use the lower ten bits of the LFSR counter for the wait countdown. If the BOLMT is 10, then it will only use the value in the first four bits for the wait countdown, etc.</p> <p>Note 4.4 Slot-time = 512 bit times. (See IEEE 802.3 Spec., Secs. 4.2.3.25 and 4.4.2.1)</p>	BOLMT Value	# Bits Used from LFSR Counter	2'b00	10	2'b01	8	2'b10	4	2'b11	1	R/W	00b
BOLMT Value	# Bits Used from LFSR Counter												
2'b00	10												
2'b01	8												
2'b10	4												
2'b11	1												
5	<p>Deferral Check (DFCHK) When set, enables the deferral check in the MAC. The MAC will abort the transmission attempt if it has deferred for more than 24,288 bit times. Deferral starts when the transmitter is ready to transmit, but is prevented from doing so because the CRS is active. Defer time is not cumulative. If the transmitter defers for 10,000 bit times, then transmits, collides, backs off, and then has to defer again after completion of back-off, the deferral timer resets to 0 and restarts. When reset, the deferral check is disabled in the MAC and the MAC defers indefinitely.</p>	R/W	0b										
4	RESERVED	RO	-										
3	<p>Transmitter enable (TXEN) When set, the MAC's transmitter is enabled and it will transmit frames from the buffer onto the cable. When reset, the MAC's transmitter is disabled and will not transmit any frames.</p>	R/W	0b										

Datasheet

BITS	DESCRIPTION	TYPE	DEFAULT
2	<p>Receiver Enable (RXEN) When set (1), the MAC's receiver is enabled and will receive frames from the internal PHY. When reset, the MAC's receiver is disabled and will not receive any frames from the internal PHY.</p> <p>Note: In order to successfully enable the receive path, the RX DMAC must be enabled by setting the Start/Stop Receive bit (SR) bit of the DMA Controller Control (Operation Mode) Register (DMAC_CONTROL) prior to enabling the receiver (by setting RXEN).</p> <p>Note: In order to successfully disable the receive path, the receiver must be disabled (by clearing RXEN) prior to disabling the RX DMAC (by clearing the Start/Stop Receive bit (SR) bit of the DMA Controller Control (Operation Mode) Register (DMAC_CONTROL)). Otherwise, RX DMA will not stop (DMAC_STATUS will continue to show the Receive Process State (RS) as Running and Receive Process Stopped (RPS) does not assert).</p>	R/W	0b
1-0	RESERVED	RO	-

4.4.2 MAC Address High Register (ADDRH)

Offset: 0084h Size: 32 bits

This register contains the upper 16 bits of the physical address of the MAC, where ADDRH[15:8] is the 6th octet of the RX frame.

BITS	DESCRIPTION	TYPE	DEFAULT
31:16	RESERVED	RO	-
15-0	Physical Address [47:32] This field contains the upper 16 bits (47:32) of the physical address of the LAN9420/LAN9420i device.	R/W	FFFFh

4.4.3 MAC Address Low Register (ADDRL)

Offset: 0088h Size: 32 bits

This register contains the lower 32 bits of the physical address of the MAC, where ADDRL[7:0] is the first octet of the Ethernet frame.

BITS	DESCRIPTION	TYPE	DEFAULT
31:0	Physical Address [31:0] This field contains the lower 32 bits (32:0) of the Physical Address of this MAC device.	R/W	32'hF

Table 4.6 below illustrates the byte ordering of the ADDRL and ADDRH registers with respect to the reception of the Ethernet physical address.

Table 4.6 ADDRL, ADDRH Byte Ordering

ADDRL, ADDRH	ORDER OF RECEPTION ON ETHERNET
ADDRL[7:0]	1 st
ADDRL[15:8]	2 nd
ADDRL[23:16]	3 rd
ADDRL[31:24]	4 th
ADDRH[7:0]	5 th
ADDRH[15:8]	6 th

As an example, if the desired Ethernet physical address is 12-34-56-78-9A-BC, the ADDRL and ADDRH registers would be programmed as shown in Figure 4.2. The values required to automatically load this configuration from the EEPROM are shown in Section 3.3.5.1, "EEPROM Format," on page 31.



Figure 4.2 Example ADDRL, ADDRH Address Ordering

4.4.4 Multicast Hash Table High Register (HASHH)

Offset: 008Ch Size: 32 bits

The 64-bit Multicast table is used for group address filtering. For hash filtering, the contents of the destination address in the incoming frame is used to index the contents of the Hash table. The most significant bit determines the register to be used (Hi/Low), while the other five bits determine the bit within the register. A value of 00000 selects Bit 0 of the Multicast Hash Table Lo register and a value of 11111 selects the Bit 31 of the Multicast Hash Table Hi register.

If the corresponding bit is 1, then the multicast frame is accepted. Otherwise, it is rejected. If the "Pass All Multicast" (MCPAS) bit is set (1), then all multicast frames are accepted regardless of the multicast hash values.

The Multicast Hash Table Hi register contains the higher 32 bits of the hash table and the Multicast Hash Table Low register contains the lower 32 bits of the hash table.

BITS	DESCRIPTION	TYPE	DEFAULT
31-0	Upper 32 bits of the 64-bit Hash Table	R/W	32'h0

4.4.5 Multicast Hash Table Low Register (HASHL)

Offset: 0090h Size: 32 bits

This register defines the lower 32-bits of the Multicast Hash Table. Please refer to [Section 4.4.4, "Multicast Hash Table High Register \(HASHH\)," on page 126](#) for further details.

BITS	DESCRIPTION	TYPE	DEFAULT
31-0	Lower 32 bits of the 64-bit Hash Table	R/W	32'h0

4.4.6 MII Access Register (MII_ACCESS)

Offset: 0094h Size: 32 bits

This register is used to control the management cycles to the internal PHY.

BITS	DESCRIPTION	TYPE	DEFAULT
31-16	RESERVED	RO	-
15-11	PHY Address For every access to this register, this field must be set to 00001b.	R/W	00000b
10-6	MII Register Index (MIIRINDA) These bits select the desired MII register in the PHY.	R/W	00000b
5-2	RESERVED	RO	-
1	MII Write (MIIWnR) Setting this bit tells the PHY that this will be a write operation using the MII data register. If this bit is not set, this will be a read operation, packing the data in the MII data register.	R/W	0b
0	MII Busy (MIIBZY) This bit must be polled to determine when the MII register access is complete. This bit must read a logical 0 before writing to this register or to the MII data register. The LAN driver software must set (1) this bit in order for the Host system to read or write any of the MII PHY registers. During a MII register access, this bit will be set, signifying a read or write access is in progress. The MII data register must be kept valid until the MAC clears this bit during a PHY write operation. The MII data register is invalid until the MAC has cleared this bit during a PHY read operation.	R/W/SC	0b

4.4.7 MII Data Register (MII_DATA)

Offset: 0098h Size: 32 bits

This register contains either the data to be written to the PHY register specified in the MII Access Register, or the read data from the PHY register whose index is specified in the MII Access Register. Refer to [Section 4.4.6, "MII Access Register \(MII_ACCESS\)," on page 128](#) for further details.

Note: The MIIBZY bit in the MII_ACCESS register must be cleared when writing to this register.

BITS	DESCRIPTION	TYPE	DEFAULT
31-16	RESERVED	RO	-
15-0	MII Data This contains the 16-bit value read from the PHY read operation or the 16-bit data value to be written to the PHY before an MII write operation.	R/W	0000h

4.4.8 Flow Control Register (FLOW)

Offset: 009Ch Size: 32 bits

This register is used to control the generation and reception of the Control frames by the MAC's flow control block. A write to this register with busy bit set to 1 will trigger the Flow control block to generate a Control frame. Before writing to this register, the application has to make sure that the busy bit is not set.

BITS	DESCRIPTION	TYPE	DEFAULT
31:16	Pause Time (FCPT) This field indicates the value to be used in the PAUSE TIME field in the control frame.	R/W	0000h
15:3	RESERVED	RO	-
2	Pass Control Frames (FCPASS) When set, the MAC sets the packet filter bit in the receive packet status to indicate to the application that a valid pause frame has been received. The application must accept or discard a received frame based on the packet filter control bit. The MAC receives, decodes and performs the pause function when a valid pause frame is received in full-duplex mode and when flow control is enabled (FCE bit set). When reset, the MAC resets the packet filter bit in the receive packet status. The MAC always passes the data of all frames it receives (including flow control frames) to the application. Frames that do not pass address filtering, as well as frames with errors, are passed to the application. The application must discard or retain the received frame's data based on the received frame's STATUS field. Filtering modes (promiscuous mode, for example) take precedence over the FCPASS bit.	R/W	0b
1	Flow Control Enable (FCEN) When set, enables the MAC flow control function. The MAC decodes all incoming frames for control frames; if it receives a valid control frame (PAUSE command), it disables the transmitter for a specified time (decoded pause time x slot time). When reset, the MAC flow control function is disabled; the MAC does not decode frames for control frames. Note: Flow Control is applicable when the MAC is set in full duplex mode.	R/W	0b
0	Flow Control Busy (FCBSY) In full-duplex mode this bit should read logical 0 before writing to the flow control register. To initiate a PAUSE control frame, the Host system must set this bit to 1. During a transfer of control frame, this bit continues to be set, signifying that a frame transmission is in progress. After the PAUSE control frame's transmission is complete, the MAC resets to 0.	R/W	0b

Datasheet

4.4.9 VLAN1 Tag Register (VLAN1)

Offset: 00A0h Size: 32 bits

This register contains the VLAN tag field to identify VLAN1 frames. For VLAN frames the legal frame length is increased from 1518 bytes to 1522 bytes.

The RXCOE also uses this register to determine the protocol value to use to indicate the existence of a VLAN tag. When using the RXCOE, this value may only be changed if the RX path is disabled. If it is desired to change this value during run time, it is safe to do so only after the MAC is disabled and the MIL is empty.

BITS	DESCRIPTION	TYPE	DEFAULT
31:16	RESERVED	RO	-
15:0	VLAN1 Tag Identifier (VTI1) This contains the VLAN Tag field to identify the VLAN1 frames. This field is compared with the 13 th and 14 th bytes of the incoming frames for VLAN1 frame detection.	R/W	FFFFh

4.4.10 VLAN2 Tag Register (VLAN2)

Offset: 00A4h Size: 32 bits

This register contains the VLAN tag field to identify VLAN2 frames. For VLAN frames the legal frame length is increased from 1518 bytes to 1522 bytes.

BITS	DESCRIPTION	TYPE	DEFAULT
31:16	RESERVED	RO	-
15:0	VLAN2 Tag Identifier (VTI2) This contains the VLAN Tag field to identify the VLAN2 frames. This field is compared with the 13 th and 14 th bytes of the incoming frames for VLAN2 frame detection.	R/W	FFFFh

4.4.11 Wakeup Frame Filter (WUFF)

Offset: 00A8h Size: 32 bits

This register is used to configure the Wakeup Frame Filter.

BITS	DESCRIPTION	TYPE	DEFAULT
31:0	<p>Wakeup Frame Filter (WFF) The Wakeup Frame Filter is configured through this register using an indexing mechanism. Following a reset, the MAC loads the first value written to this location to the first DWORD in the Wakeup Frame Filter (filter 0 byte mask). The second value written to this location is loaded to the second DWORD in the wakeup Frame Filter (filter 1 byte mask) and so on. Once all eight DWORDs have been written, the internal pointer will once again point to the first entry and the filter entries can be modified in the same manner. Similarly, eight DWORDS should be read sequentially to obtain the values stored in the WFF.</p> <p>Note: This register should be read and written using eight consecutive DWORD operations. Failure to read or write the entire contents of the WFF may cause the internal read/write pointers to be left in a position other than pointing to the first entry.</p>	R/W	0000_0000h

4.4.12 Wakeup Control and Status Register (WUCSR)

Offset: 00ACh Size: 32 bits

This register contains data pertaining to the MAC's remote wakeup status and capabilities.

BITS	DESCRIPTION	TYPE	DEFAULT
31:10	RESERVED	RO	-
9	Global Unicast Enable (GUE) When set, the MAC wakes up from power-saving mode on receipt of a global unicast frame. A global unicast frame has the MAC Address [0] bit set to 0.		0b
8:7	RESERVED	RO	-
6	Remote Wakeup Frame Received (WUFR) The MAC sets this bit upon receiving a valid remote wakeup frame.	R/WC	0b
5	Magic Packet Received (MPR) The MAC sets this bit upon receiving a valid Magic Packet.	R/WC	0b
4-3	RESERVED	RO	-
2	Wakeup Frame Enable (WAKE_EN) When set, remote wakeup mode is enabled and the MAC is capable of detecting wakeup frames as programmed in the Wakeup Frame Filter.	R/W	0b
1	Magic Packet Enable (MPEN) When set, Magic Packet wakeup mode is enabled.	R/W	0b
0	RESERVED	RO	-

4.4.13 Checksum Offload Engine Control Register (COE_CR)

Offset: 00B0h Size: 32 bits

This register controls the RX and TX checksum offload engines.

BITS	DESCRIPTION	TYPE	DEFAULT
31:17	RESERVED	RO	-
16	<p>TX Checksum Offload Engine Enable (TX_COE_EN) The COE_EN may only be changed if the TX path is disabled. If it is desired to disable the TX_COE_EN during run time, it is safe to do so only after the MAC is disabled and the MIL is empty.</p> <p>0: The TXCOE is bypassed 1: The TXCOE is enabled</p>	R/W	0b
15:2	RESERVED	RO	-
1	<p>RX Checksum Offload Engine Mode (RX_COE_MODE) This register indicates whether the COE will check for VLAN tags or a SNAP header prior to beginning its checksum calculation. In its default mode, the calculation will always begin 14 bytes into the frame.</p> <p>The COE_MODE may only be changed if the RX path is disabled. If it is desired to change this value during run time, it is safe to do so only after the MAC is disabled and the MIL is empty.</p> <p>0: Begin checksum calculation after first 14 bytes of Ethernet Frame 1: Begin checksum calculation at start of L3 packet by adjusting for VLAN tags and/or SNAP header.</p>	R/W	0b
0	<p>RX Checksum Offload Engine Enable (RX_COE_EN) The COE_EN may only be changed if the RX path is disabled. If it is desired to disable the COE_EN during run time, it is safe to do so only after the MAC is disabled and the MIL is empty.</p> <p>0: The RXCOE is bypassed 1: The RXCOE is enabled</p> <p>Note: When the RXCOE is enabled, automatic pad stripping must be disabled (PADSTR bit of the MAC Control Register (MAC_CR)) and vice versa. These functions cannot be enabled simultaneously.</p>	R/W	0b

4.5 PHY Registers

The PHY registers are not memory mapped. These registers are accessed indirectly through the MAC via the MII_ACCESS and MII_DATA registers. An index is used to access individual PHY registers. PHY Register Indexes are shown in [Table 4.7, "PHY Control and Status Registers"](#) below.

Note: The NASR (**Not Affected by Software Reset**) designation is only applicable when bit 15 of the PHY Basic Control Register (Reset) is set.

Table 4.7 PHY Control and Status Registers

INDEX (IN DECIMAL)	REGISTER NAME
0	Basic Control Register
1	Basic Status Register
2	PHY Identifier 1
3	PHY Identifier 2
4	Auto-Negotiation Advertisement Register
5	Auto-Negotiation Link Partner Ability Register
6	Auto-Negotiation Expansion Register
17	Mode Control/Status Register
18	Special Modes
27	Control / Status Indication Register
29	Interrupt Source Register
30	Interrupt Mask Register
31	PHY Special Control/Status Register

4.5.1 Basic Control Register

Index (In Decimal): 0

Size: 16 bits

BITS	DESCRIPTION	TYPE	DEFAULT
15	PHY Soft Reset 1 = PHY software reset. Bit is self-clearing. When setting this bit do not set other bits in this register.	R/W/SC	0b
14	Loopback 1 = loopback mode, 0 = normal operation	R/W	0b
13	Speed Select 1 = 100Mbps, 0 = 10Mbps. Ignored if Auto Negotiation is enabled (0.12 = 1).	R/W	1b
12	Auto-Negotiation Enable 1 = enable auto-negotiate process (overrides 0.13 and 0.8) 0 = disable auto-negotiate process.	R/W	1b
11	Power Down 1 = General Power-Down mode, 0 = normal operation Note: For maximum power savings, auto-negotiation should be disabled before enabling the General Power-Down mode.	R/W	0b
10	RESERVED	RO	-
9	Restart Auto-Negotiate 1 = restart auto-negotiate process 0 = normal operation. Bit is self-clearing.	R/W/SC	0b
8	Duplex Mode 1 = full duplex, 0 = half duplex. Ignored if Auto Negotiation is enabled (0.12 = 1).	R/W	0b
7	Collision Test 1 = enable COL test, 0 = disable COL test	R/W	0b
6:0	RESERVED	RO	-

4.5.2 Basic Status Register

Index (In Decimal): 1

Size: 16 bits

BITS	DESCRIPTION	TYPE	DEFAULT
15	100BASE-T4 1 = T4 able, 0 = no T4 ability	RO	0b
14	100BASE-TX Full Duplex 1 = TX with full duplex, 0 = no TX full duplex ability.	RO	1b
13	100BASE-TX Half Duplex 1 = TX with half duplex, 0 = no TX half duplex ability.	RO	1b
12	10BASE-T Full Duplex 1 = 10Mbps with full duplex 0 = no 10Mbps with full duplex ability	RO	1b
11	10BASE-T Half Duplex 1 = 10Mbps with half duplex 0 = no 10Mbps with half duplex ability	RO	1b
10:6	RESERVED	RO	-
5	Auto-Negotiate Complete 1 = auto-negotiate process completed 0 = auto-negotiate process not completed	RO	0b
4	Remote Fault 1 = remote fault condition detected 0 = no remote fault	RO/LH	0b
3	Auto-Negotiate Ability 1 = able to perform auto-negotiation function 0 = unable to perform auto-negotiation function	RO	1b
2	Link Status 1 = link is up, 0 = link is down	RO/LL	0b
1	Jabber Detect 1 = jabber condition detected 0 = no jabber condition detected	RO/LH	0b
0	Extended Capabilities 1 = supports extended capabilities registers 0 = does not support extended capabilities registers.	RO	1b

Datasheet**4.5.3 PHY Identifier 1**

Index (In Decimal): 2

Size: 16 bits

BITS	DESCRIPTION	TYPE	DEFAULT
15:0	PHY ID Number Assigned to the 3rd through 18th bits of the Organizationally Unique Identifier (OUI), respectively.	R/W	0007h

4.5.4 PHY Identifier 2

Index (In Decimal): 3

Size: 16 bits

BITS	DESCRIPTION	TYPE	DEFAULT
15:10	PHY ID Number b Assigned to the 19th through 24th bits of the OUI.	R/W	C0C3h
9:4	Model Number Six-bit manufacturer's model number.	R/W	
3:0	Revision Number Four-bit manufacturer's revision number.	R/W	

4.5.5 Auto Negotiation Advertisement

Index (In Decimal): 4

Size: 16 bits

BITS	DESCRIPTION	TYPE	DEFAULT
15	RESERVED	R/W	0b
14	RESERVED	RO	-
13	Remote Fault 1 = remote fault detected, 0 = no remote fault	R/W	0b
12	RESERVED	R/W	-
11:10	Pause Operation (See Note 4.5) 00 No PAUSE 01 Symmetric PAUSE 10 Asymmetric PAUSE 11 Advertise support for both symmetric PAUSE and Asymmetric PAUSE	R/W	00b
9	RESERVED	R/W	0b
8	100BASE-TX Full Duplex 1 = TX with full duplex, 0 = no TX full duplex ability	R/W	1b
7	100BASE-TX 1 = TX able, 0 = no TX ability	R/W	1b
6	10BASE-T Full Duplex 1 = 10Mbps with full duplex 0 = no 10Mbps with full duplex ability	R/W	1b
5	10BASE-T 1 = 10Mbps able, 0 = no 10Mbps ability	R/W	1b
4:0	Selector Field [00001] = IEEE 802.3	R/W	00001b

Note 4.5 When both symmetric PAUSE and asymmetric PAUSE support are advertised (value of 11), the device will only be configured to, at most, one of the two settings upon auto-negotiation completion.

4.5.6 Auto Negotiation Link Partner Ability

Index (In Decimal): 5

Size: 16 bits

BITS	DESCRIPTION	TYPE	DEFAULT
15	Next Page 1 = next page capable, 0 = no next page ability. This device does not support next page ability.	RO	0b
14	Acknowledge 1 = link code word received from partner 0 = link code word not yet received	RO	0b
13	Remote Fault 1 = remote fault detected, 0 = no remote fault	RO	0b
12	RESERVED	RO	-
11:10	Pause Operation 00 No PAUSE supported by partner station 01 Symmetric PAUSE supported by partner station 10 Asymmetric PAUSE supported by partner station 11 Both Symmetric PAUSE and Asymmetric PAUSE supported by partner station	RO	00b
9	100BASE-T4 1 = T4 able, 0 = no T4 ability	RO	0b
8	100BASE-TX Full Duplex 1 = TX with full duplex, 0 = no TX full duplex ability	RO	0b
7	100BASE-TX 1 = TX able, 0 = no TX ability	RO	0b
6	10BASE-T Full Duplex 1 = 10Mbps with full duplex 0 = no 10Mbps with full duplex ability	RO	0b
5	10BASE-T 1 = 10Mbps able, 0 = no 10Mbps ability	RO	0b
4:0	Selector Field [00001] = IEEE 802.3	RO	00001b

4.5.7 Auto Negotiation Expansion

Index (In Decimal): 6

Size: 16 bits

BITS	DESCRIPTION	TYPE	DEFAULT
15:5	RESERVED	RO	-
4	Parallel Detection Fault 1 = fault detected by parallel detection logic 0 = no fault detected by parallel detection logic	RO/LH	0b
3	Link Partner Next Page Able 1 = link partner has next page ability 0 = link partner does not have next page ability	RO	0b
2	Next Page Able 1 = local device has next page ability 0 = local device does not have next page ability	RO	0b
1	Page Received 1 = new page received 0 = new page not yet received	RO/LH	0b
0	Link Partner Auto-Negotiation Able 1 = link partner has auto-negotiation ability 0 = link partner does not have auto-negotiation ability	RO	0b

4.5.8 Mode Control/Status

Index (In Decimal): 17

Size: 16 bits

BITS	DESCRIPTION	TYPE	DEFAULT
15:14	RESERVED	RO	-
13	EDPWRDOWN Enable the Energy Detect Power-Down mode: 0=Energy Detect Power-Down is disabled 1=Energy Detect Power-Down is enabled	R/W	0b
12:2	RESERVED	RO	-
1	ENERGYON Indicates whether energy is detected. This bit goes to a "0" if no valid energy is detected within 256ms. Reset to "1" by hardware reset, unaffected by SW reset.	RO	1b
0	RESERVED	R/W	0b

4.5.9 Special Modes

Index (In Decimal): 18

Size: 16 bits

BITS	DESCRIPTION	TYPE	DEFAULT
15:8	RESERVED	RO	-
7-5	MODE PHY Mode of operation. Refer to Table 4.8 for more details.	R/W NASR	111b
4-0	PHYADD PHY Address. The PHY Address is used for the SMI address.	R/W NASR	00001b

Table 4.8 MODE Control

MODE	MODE DEFINITIONS	DEFAULT REGISTER BIT VALUES	
		REGISTER 0	REGISTER 4
		[13,12,8]	[8,7,6,5]
000b	10BASE-T Half Duplex. Auto-negotiation disabled.	000	N/A
001b	10BASE-T Full Duplex. Auto-negotiation disabled.	001	N/A
010b	100BASE-TX Half Duplex. Auto-negotiation disabled. CRS is active during Transmit & Receive.	100	N/A
011b	100BASE-TX Full Duplex. Auto-negotiation disabled. CRS is active during Receive.	101	N/A
100b	100base-TX Half Duplex is advertised. Auto-negotiation enabled. CRS is active during Transmit & Receive.	110	0100
101b	Repeater mode. Auto-negotiation enabled. 100BASE-TX Half Duplex is advertised. CRS is active during Receive.	110	0100
110b	RESERVED - Do not set LAN9420/LAN9420i in this mode.	N/A	N/A
111b	All capable. Auto-negotiation enabled.	X1X	1111

4.5.10 Special Control/Status Indications

Index (In Decimal): 27

Size: 16 bits

BITS	DESCRIPTION	TYPE	DEFAULT
15	Override AUTOMDIX_EN Strap 0 = AUTOMDIX_EN configuration strap enables or disables HP Auto MDIX. 1 = Override AUTOMDIX_EN configuration strap. PHY Register 27.14 and 27.13 determine MDIX function.	R/W	0b
14	Auto-MDIX Enable Only effective when 27.15=1, otherwise ignored. 0 = Disable Auto-MDIX. 27.13 determines normal or reversed connection. 1 = Enable Auto-MDIX. 27.13 must be set to 0.	R/W	0b
13	Auto-MDIX State Only effective when 27.15=1, otherwise ignored. When 27.14 = 0 (manually set MDIX state): 0 = no crossover (TPO = output, TPI = input) 1 = crossover (TPO = input, TPI = output) When 27.14 = 1 (automatic MDIX) this bit must be set to 0. Do not use the combination 27.15=1, 27.14=1, 27.13=1.	R/W	0b
12:11	RESERVED	RO	-
10	VCOFF_LP Forces the Receive PLL 10M to lock on the reference clock at all times: 0 – Receive PLL 10M can lock on reference or line as needed (normal operation) 1 - Receive PLL 10M is locked on the reference clock. In this mode 10M data packets cannot be received.	R/W, NASR	0b
9:5	RESERVED	RO	-
4	XPOL Polarity state of the 10BASE-T: 0 – Normal polarity 1 – Reversed polarity	RO	0b
3:0	RESERVED	RO	-

4.5.11 Interrupt Source Flag

Index (In Decimal): 29

Size: 16 bits

BITS	DESCRIPTION	TYPE	DEFAULT
15:8	RESERVED	RO	-
7	INT7 1= ENERGYON generated, 0 = not source of interrupt	RO/LH	0b
6	INT6 1= Auto-Negotiation complete, 0 = not source of interrupt	RO/LH	0b
5	INT5 1= Remote Fault Detected, 0 = not source of interrupt	RO/LH	0b
4	INT4 1= Link Down (link status negated), 0 = not source of interrupt	RO/LH	0b
3	INT3 1= Auto-Negotiation LP Acknowledge, 0 = not source of interrupt	RO/LH	0b
2	INT2 1= Parallel Detection Fault, 0 = not source of interrupt	RO/LH	0b
1	INT1 1= Auto-Negotiation Page Received, 0 = not source of interrupt	RO/LH	0b
0	RESERVED	RO	0b

4.5.12 Interrupt Mask

Index (In Decimal): 30

Size: 16 bits

BITS	DESCRIPTION	TYPE	DEFAULT
15:8	RESERVED	RO	-
7:0	Mask Bits 1 = interrupt source is enabled, 0 = interrupt source is masked	R/W	00h

4.5.13 PHY Special Control/Status

Index (In Decimal): 31

Size: 16 bits

BITS	DESCRIPTION	TYPE	DEFAULT
15:13	RESERVED	RO	-
12	Autodone Auto-negotiation done indication: 0 = Auto-negotiation is not done or disabled (or not active) 1 = Auto-negotiation is done	RO	0
11:5	RESERVED Write as 0000010b, ignore on read.	Note 4.6	-
4:2	Speed Indication HCDSPEED value: [001b] = 10Mbps half-duplex [101b] = 10Mbps full-duplex [010b] = 100BASE-TX half-duplex [110b] = 100BASE-TX full-duplex	RO	000b
1:0	RESERVED	RO	-

Note 4.6 Bit 6 of this register must be set to '1' for write operations.

4.6 PCI Configuration Space CSR (CONFIG CSR)

Configuration and read back of the CONFIG CSR is accomplished by the Host processor via the PCI bus. These registers assume their default value on assertion of a chip-level reset or when the device power state transitions from D3 to D0. See [Section 3.7, "Power Management," on page 74](#) for details.

Registers in offsets 00h - 03Fh are standard PCI header registers, as described in the PCI Local Bus Specification Revision 3.0. Please refer to the specification for further details.

Register 78h is a PCIB specific extension related to power management.

The following is the register map for the PCI Configuration Space CSR (CONFIG CSR):

Table 4.9 PCI Configuration Space CSR (CONFIG CSR) Address Map

CONFIGURATION SPACE OFFSET	REGISTER NAME	DESCRIPTION
00h – 3Fh	-	Standard PCI Header Registers (See Table 4.10 on page 151 for details).
40h – 74h	RESERVED	
78h	PCI_PMC	PCI Power Management Capabilities Register (PCI_PMC)
7Ch	PCI_PMCSR	PCI Power Management Control and Status Register (PCI_PMCSR)

Table 4.10 lists the standard PCI header registers that are supported. Registers whose initial values for Subsystem Vendor ID and Subsystem Device ID, are configured from the EEPROM are indicated by 'YES' in the "EEPROM CONFIGURABLE" column.

Table 4.10 Standard PCI Header Registers Supported

CONFIGURATION SPACE OFFSET	REGISTER NAME	READ/ WRITE	DEFAULT	EEPROM CONFIGURABLE
00h - 01h	Vendor ID	RO	1055h	
02h - 03h	Device ID	RO	E420h	
04h - 05h	Command	R/W	00h	
06h - 07h	Status	RO, R/WC	0410h	
08h	Revision ID	RO	Note 4.7	
09h - 0Bh	Class Code	RO	020000h	
0Ch	Cache Line Size	R/W	00h	
0Dh	Latency Timer	R/W	00h	
0Eh	Header Type	RO	00h	
0F - 1Bh	RESERVED	RO		
1Ch - 1Fh	BAR 3 (Note 4.8) (For NP-Mem mapped 1Kbyte)	R/W	00000000h (FFFFFC00h)	
20h - 23h	BAR 4 (Note 4.8) (For I/O mapped 256byte)	R/W	0000001h (FFFFFF01h)	
24h - 2Bh	RESERVED	RO		
2Ch - 2Dh	Subsystem Vendor ID (SSVID) (Note 4.9)	RO	1055h	YES
2EH - 2Fh	Subsystem Device ID (SSID) (Note 4.9)	RO	9420h	YES
30h - 33h	RESERVED	RO		
34h	Capabilities Pointer	RO	78h	
35h - 3Bh	RESERVED	RO		
3Ch	Interrupt Line	R/W	00h	
3Dh	Interrupt Pin	RO	01h	
3Eh	Min_Gnt	RO	02h	
3Fh	Max_Lat	RO	04h	

Note 4.7 Default value is dependent on device revision.

Note 4.8 BAR3's read back value is FFFFFFFC00h after writing FFFFFFFFh. BAR4's read back value is FFFFFFF01h after writing FFFFFFFFh.

Note 4.9 The Subsystem Vendor ID and Subsystem Device ID can be configured by the serial EEPROM. if no EEPROM is connected to LAN9420/LAN9420i, then the default values in the table are used.

4.6.1 PCI Power Management Capabilities Register (PCI_PMC)

Offset: 78h Size: 32 bits

This register implements the standard capability structure used to define power management features in a PCI device. The capabilities structure is documented in the *PCI Bus Power Management Interface Specification Revision 1.1*. The host uses this register check supported power states and features.

Note: The format of this register is equivalent to offsets 3:0 of the Power Management Register Block Definition as described in the *PCI Bus Power Management Interface Specification Revision 1.1*.

BITS	DESCRIPTION	TYPE	DEFAULT
31	PME Support from D3_{COLD} (PME_IN_D3C) When this bit is set, LAN9420/LAN9420i is capable asserting nPME from the D3 _{COLD} state. When this bit is cleared, the device will not assert nPME from the D3 _{COLD} state. This bit reflects the setting of the VAUXDET input pin.	RO	Note 4.10
30	PME Support from D3_{HOT} (PME_IN_D3H) This bit is set indicating that LAN9420/LAN9420i is capable asserting nPME from the D3 _{HOT} state.	RO	1b
29	PME Support from D2 (PME_IN_D2) This bit is cleared since LAN9420/LAN9420i does not support the D2 power management state.	RO	0b
28	PME Support from D1 (PME_IN_D1) This bit is cleared since LAN9420/LAN9420i does not support the D1 power management state.	RO	0b
27	PME Support from D0 (PME_IN_D0) This bit is set indicating that LAN9420/LAN9420i is capable asserting nPME from the D0 state.	RO	1b
26	D2 Power State Support (D2_SUP) This bit is cleared since LAN9420/LAN9420i does not support the D2 power management state.	RO	0b
25	D1 Power State Support (D1_SUP) This bit is cleared since LAN9420/LAN9420i does not support the D1 power management state.	RO	0b
24:22	3.3Vaux Power Supply Current Draw (AUX_CURRENT) This field indicates the auxiliary power requirements for the LAN9420/LAN9420i device. This field is dependant on the state of the VAUXDET input pin. When VAUXDET is cleared, this field is cleared to 000b to indicate that there is no current draw from the 3.3Vaux power supply. When VAUXDET is set, this field is set to a value of 110b to indicate a current draw of 320mA from the 3.3Vaux power supply.	RO	Note 4.10
21	Device Specific Initialization (DSI) This bit returns zero, indicating that there are no device specific initialization requirements.	RO	0b
20	RESERVED	RO	0b
19	PME Clock (CLK4PME) This bit is cleared to indicate that LAN9420/LAN9420i does not require the presence of PCICLK in order to assert nPME.	RO	0b

Datasheet

BITS	DESCRIPTION	TYPE	DEFAULT
18:16	Power Management Specification Version (VERSION[2:0]) This device complies with Revision 1.1 of the <i>PCI Bus Power Management Interface Specification</i> .	RO	010b
15:8	Next Item Offset (NEXT_OFFSET[7:0]) There is only a single item in the capabilities list. No other list elements follow. This field will always return 0h.	RO	0h
7:0	Capability ID (CAP_ID) This is the capability identifier for PCI Power Management Interface. It identifies the link list item as being the PCI Power Management registers.	RO	01h

Note 4.10 The default state of this field is dependant on the setting of the VAUXDET signal as noted in the description.

4.6.2 PCI Power Management Control and Status Register (PCI_PMCSR)

Offset: 7Ch Size: 32 bits

This register controls the device's power state.

Note: The format of this register is equivalent to offsets 7:4 of the Power Management Register Block Definition as described in Revision 1.1 of the *PCI Bus Power Management Interface Specification*.

BITS	DESCRIPTION	TYPE	DEFAULT
31:24	Data (PM_DATA) This field is not implemented and returns zeros.	RO	00h
23:16	PMCSR PCI to PCI Bridge Support Extensions (PMCSR_BSE) This field is not implemented and returns zeros.	RO	00h
15	PME Status (PME_STATUS) This bit is set when an enabled power management event has been detected. Writing a "1" to this bit will clear it provided that the source of the event has been cleared. This bit is level-triggered and will not clear on write if the source of the power management event remains asserted. Writing a "0" has no effect. When the VAUXDET input pin is low, this bit is reset on assertion of a power-on reset or PCI reset (PCInRST). When the VAUXDET input pin is high, this bit is unaffected by assertion of PCI reset (PCInRST). In this case, the bit will maintain its setting until cleared with a write, or until assertion of a power-on reset.	R/WC	Note 4.11
14:13	Data Scale (DATA_SCALE) This field is not implemented and returns zeros as a result of the PM_DATA field of this register not being implemented.	RO	00b
12:9	Data Select (DATA_SELECT) This field is not implemented and returns zeros as a result of the PM_DATA field of this register not being implemented.	RO	0000b
8	PME Enable (PME_EN) When this bit is set, the device will assert the external nPME signal if the PME Status (PME_STATUS) bit in this register is set. When this bit is cleared, the device will not assert the external nPME signal. When the VAUXDET input pin is cleared, this bit is reset on assertion of a power-on reset or PCI reset (PCInRST). When the VAUXDET input pin is set, this bit is unaffected by assertion of PCI reset (PCInRST). In this case, the bit will maintain its setting until cleared with a write, or until assertion of a power-on reset. If PME_EN is cleared, the device will automatically place the PHY into General Power-Down when entering the D3 _{HOT} state.	R/W	Note 4.11
7:2	RESERVED	RO	-

Datasheet

BITS	DESCRIPTION	TYPE	DEFAULT
1:0	<p>Power Management State (PM_STATE) This field sets the current PM state. 00b = D0 01b = RESERVED 10b = RESERVED 11b = D3</p> <p>Operations that attempt to write a RESERVED setting to this field will complete normally on the PCI bus; however D[1:0] are ignored and no state change occurs.</p>	R/W	00b

Note 4.11 The default state of this field is dependant on the setting of the VAUXDET signal as noted in the description.

Chapter 5 Operational Characteristics

5.1 Absolute Maximum Ratings*

Supply Voltage (VDD33A, VDD33BIAS, VDD33IO) (Note 5.1)	0V to +3.6V
Positive voltage on signal pins, with respect to ground (Note 5.2)	+6V
Negative voltage on signal pins, with respect to ground (Note 5.3)	-0.5V
Positive voltage on XI, with respect to ground	+4.6V
Positive voltage on XO, with respect to ground	+2.5V
Ambient Operating Temperature in Still Air (T_A)	Note 5.4
Storage Temperature	-55°C to +150°C
Lead Temperature Range	Refer to JEDEC Spec. J-STD-020
HBM ESD Performance	+/- 5kV

Note 5.1 When powering this device from laboratory or system power supplies, it is important that the absolute maximum ratings not be exceeded or device failure can result. Some power supplies exhibit voltage spikes on their outputs when AC power is switched on or off. In addition, voltage transients on the AC power line may appear on the DC output. If this possibility exists, it is suggested that a clamp circuit be used.

Note 5.2 This rating does not apply to the following pins: XI, XO, EXRES.

Note 5.3 This rating does not apply to the following pins: EXRES.

Note 5.4 0°C to +70°C for commercial version, -40°C to +85°C for industrial version.

*Stresses exceeding those listed in this section could cause permanent damage to the device. This is a stress rating only. Exposure to absolute maximum rating conditions for extended periods may affect device reliability. Functional operation of the device at any condition exceeding those indicated in Section 5.2, "Operating Conditions**", Section 5.4, "DC Specifications", or any other applicable section of this specification is not implied. Note, device signals are *NOT* 5 volt tolerant.

5.2 Operating Conditions**

Supply Voltage (VDD33A, VDD33BIAS, VDD33IO)	+3.3V +/- 300mV
Ambient Operating Temperature in Still Air (T_A)	Note 5.4

**Proper operation of LAN9420/LAN9420i is guaranteed only within the ranges specified in this section.

5.3 Power Consumption

This section details the power consumption of LAN9420/LAN9420i as measured during various modes of operation. Power consumption values are provided for both the device-only, and for the device plus Ethernet components.

Note: Power dissipation is determined by operating frequency, temperature, and supply voltage, as well as external source/sink requirements.

5.3.1 D0 - Normal Operation with Ethernet Traffic

Table 5.1 D0 - Normal Operation - Supply and Current (Typical)

PARAMETER	TYPICAL (@ 3.3V)	UNIT
100BASE-TX Full Duplex		
Supply current (VDD33IO, VDD33BIAS, VDD33A)	125	mA
Power Dissipation (Device Only)	415	mW
Power Dissipation (Device and Ethernet components)	560	mW
Ambient Operating Temperature in Still Air (T_A)	25	°C
10BASE-T Full Duplex		
Supply current (VDD33IO, VDD33BIAS, VDD33A)	80	mA
Power Dissipation (Device Only)	265	mW
Power Dissipation (Device and Ethernet components)	615	mW
Ambient Operating Temperature in Still Air (T_A)	25	°C

5.3.2 D3 - Enabled for Wake Up Packet Detection

Table 5.2 D3 - Enabled for Wake Up Packet Detection - Supply and Current (Typical)

PARAMETER	TYPICAL (@ 3.3V)	UNIT
100BASE-TX Full Duplex		
Supply current (VDD33IO, VDD33BIAS, VDD33A)	76	mA
Power Dissipation (Device Only)	252	mW
Power Dissipation (Device and Ethernet components)	400	mW
Ambient Operating Temperature in Still Air (T _A)	25	°C
10BASE-T Full Duplex		
Supply current (VDD33IO, VDD33BIAS, VDD33A)	40	mA
Power Dissipation (Device Only)	131	mW
Power Dissipation (Device and Ethernet components)	502	mW
Ambient Operating Temperature in Still Air (T _A)	25	°C

5.3.3 D3 - Enabled for Link Status Change Detection (Energy Detect)

Table 5.3 D3 - Enabled for Link Status Change Detection - Supply and Current (Typical)

PARAMETER	TYPICAL (@ 3.3V)	UNIT
100BASE-TX Full Duplex		
Supply current (VDD33IO, VDD33BIAS, VDD33A)	21	mA
Power Dissipation (Device Only)	70	mW
Power Dissipation (Device and Ethernet components)	70	mW
Ambient Operating Temperature in Still Air (T _A)	25	°C
10BASE-T Full Duplex		
Supply current (VDD33IO, VDD33BIAS, VDD33A)	21	mA
Power Dissipation (Device Only)	70	mW
Power Dissipation (Device and Ethernet components)	70	mW
Ambient Operating Temperature in Still Air (T _A)	25	°C

5.3.4 D3 - PHY in General Power Down Mode

Table 5.4 D3 - PHY in General Power Down Mode - Supply and Current (Typical)

PARAMETER	TYPICAL (@ 3.3V)	UNIT
100BASE-TX Full Duplex		
Supply current (VDD33IO, VDD33BIAS, VDD33A)	6	mA
Power Dissipation (Device Only)	19	mW
Power Dissipation (Device and Ethernet components)	19	mW
Ambient Operating Temperature in Still Air (T_A)	25	°C
10BASE-T Full Duplex		
Supply current (VDD33IO, VDD33BIAS, VDD33A)	6	mA
Power Dissipation (Device Only)	19	mW
Power Dissipation (Device and Ethernet components)	19	mW
Ambient Operating Temperature in Still Air (T_A)	25	°C

5.3.5 Maximum Power Consumption

Table 5.5 Maximum Power Consumption - Supply and Current (Maximum)

PARAMETER	MAXIMUM (@ 3.6V)	UNIT
100BASE-TX Full Duplex		
Supply current (VDD33IO, VDD33BIAS, VDD33A)	145	mA
Power Dissipation (Device Only)	530	mW
Power Dissipation (Device and Ethernet components)	690	mW
Ambient Operating Temperature in Still Air (T_A)	Note 5.5	°C
10BASE-T Full Duplex		
Supply current (VDD33IO, VDD33BIAS, VDD33A)	85	mA
Power Dissipation (Device Only)	310	mW
Power Dissipation (Device and Ethernet components)	700	mW
Ambient Operating Temperature in Still Air (T_A)	Note 5.5	°C

Note 5.5 Over the conditions specified in [Section 5.2, "Operating Conditions***"](#).

Note: Power dissipation is determined by temperature, supply voltage, as well as external source/sink current requirements.

5.4 DC Specifications

Table 5.6 I/O Buffer Characteristics

PARAMETER	SYMBOL	MIN	TYP	MAX	UNITS	NOTES
IS Type Input Buffer						
Low Input Level	V_{ILI}	-0.3			V	
High Input Level	V_{IHI}			3.6	V	
Negative-Going Threshold	V_{ILT}	1.01	1.18	1.35	V	Schmitt trigger
Positive-Going Threshold	V_{IHT}	1.39	1.6	1.8	V	Schmitt trigger
SchmittTrigger Hysteresis ($V_{IHT} - V_{ILT}$)	V_{HYS}	345	420	485	mV	
Input Leakage	I_{IN}	-10		10	uA	Note 5.6
Input Capacitance	C_{IN}			3	pF	
IPCI Type Input Buffer						
Low Input Level	V_{ILI}	-0.5		1.08	V	Note 5.7
High Input Level	V_{IHI}	1.5		4.1	V	
Input Leakage	I_{IN}	-10		10	uA	Note 5.8
Input Capacitance	C_{IN}			3	pF	
OPCI Type Buffer						
Low Output Level ($I_{OUT}=500\mu A$)	V_{OL}			0.3	V	Note 5.7
High Output Level ($I_{OUT}=-500\mu A$)	V_{OH}	2.7			V	
O8 Type Buffers						
Low Output Level	V_{OL}			0.4	V	$I_{OL} = 8mA$
High Output Level	V_{OH}	$V_{DD33IO} - 0.4$			V	$I_{OH} = -8mA$
O12 Type Buffers						
Low Output Level	V_{OL}			0.4	V	$I_{OL} = 12mA$
High Output Level	V_{OH}	$V_{DD33IO} - 0.4$			V	$I_{OH} = -12mA$
OD12 Type Buffer						
Low Output Level	V_{OL}			0.4	V	$I_{OL} = 12mA$
ICLK Type Buffer (XI Input)						
Low Input Level	V_{ILI}	-0.3		0.5	V	Note 5.9
High Input Level	V_{IHI}	1.4		3.6	V	

Note 5.6 This specification applies to all IS type inputs and tri-stated bi-directional non-PCI pins. Internal pull-down and pull-up resistors add +/- 50 μ A per-pin (typical)

Note 5.7 This buffer type adheres to Section 4.2.2 (3.3V Signaling Environment) of the *PCI Local Bus Specification Revision 3.0*. **Device signals are NOT 5V tolerant. This device must not be used in a 5V PCI system, or connected to 5V logic without appropriate voltage level translation.**

Note 5.8 This specification applies to all IPCI type inputs and tri-stated bi-directional PCI pins.

Note 5.9 XI can optionally be driven from a 25MHz single-ended clock oscillator.

Table 5.7 100BASE-TX Transceiver Characteristics

PARAMETER	SYMBOL	MIN	TYP	MAX	UNITS	NOTES
Peak Differential Output Voltage High	V_{PPH}	950	-	1050	mVpk	Note 5.10
Peak Differential Output Voltage Low	V_{PPL}	-950	-	-1050	mVpk	Note 5.10
Signal Amplitude Symmetry	V_{SS}	98	-	102	%	Note 5.10
Signal Rise and Fall Time	T_{RF}	3.0	-	5.0	nS	Note 5.10
Rise and Fall Symmetry	T_{RFS}	-	-	0.5	nS	Note 5.10
Duty Cycle Distortion	D_{CD}	35	50	65	%	Note 5.11
Overshoot and Undershoot	V_{OS}	-	-	5	%	
Jitter				1.4	nS	Note 5.12

Note 5.10 Measured at line side of transformer, line replaced by 100 Ω (+/- 1%) resistor.

Note 5.11 Offset from 16nS pulse width at 50% of pulse peak.

Note 5.12 Measured differentially.

Table 5.8 10BASE-T Transceiver Characteristics

PARAMETER	SYMBOL	MIN	TYP	MAX	UNITS	NOTES
Transmitter Peak Differential Output Voltage	V_{OUT}	2.2	2.5	2.8	V	Note 5.13
Receiver Differential Squelch Threshold	V_{DS}	300	420	585	mV	

Note 5.13 Min/max voltages guaranteed as measured with 100 Ω resistive load.

5.5 AC Specifications

This section contains timing information for non-PCI signals.

Note: LAN9420/LAN9420i adheres to the PCI Local Bus Specification revision 3.0. Refer to the *Conventional PCI 3.0 Specification* for PCI timing details and parameters.

5.5.1 Equivalent Test Load (Non-PCI Signals)

Output timing specifications assume the 25pF equivalent test load illustrated in [Figure 5.1](#) below.

Note: This test load is not applicable to PCI signals. These signals adhere to the PCI Local Bus Specification revision 3.0. Refer to the *Conventional PCI 3.0 Specification* for additional information.

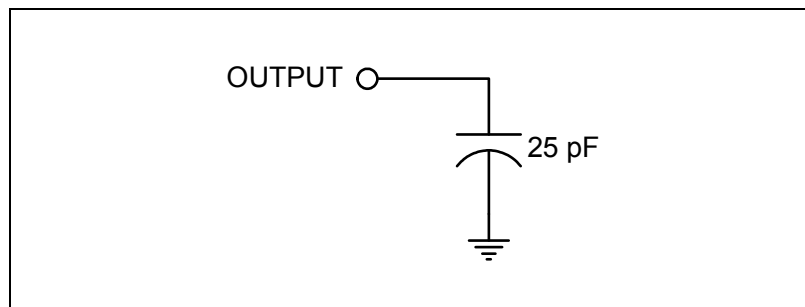

Figure 5.1 Output Equivalent Test Load

5.6 PCI Clock Timing

The following specifies the PCI clock requirements for LAN9420/LAN9420i:

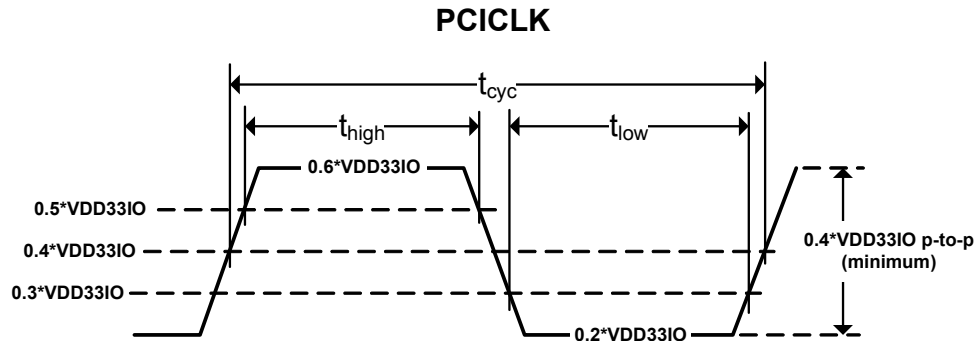

Figure 5.2 PCI Clock Timing

Table 5.9 PCI Clock Timing Values

SYMBOL	DESCRIPTION	MIN	TYP	MAX	UNITS
t_{cyc}	PCICLK cycle time	30		∞	ns
t_{high}	PCICLK high time	11			ns
t_{low}	PCICLK low time	11			ns
-	PCICLK slew rate (Note 5.14)	1		4	V/ns

Note 5.14 This slew rate must be met across the minimum peak-to-peak portion of the clock waveform as shown in Figure 5.2.

5.7 PCI I/O Timing

The following specifies the PCI I/O requirements for LAN9420/LAN9420i:

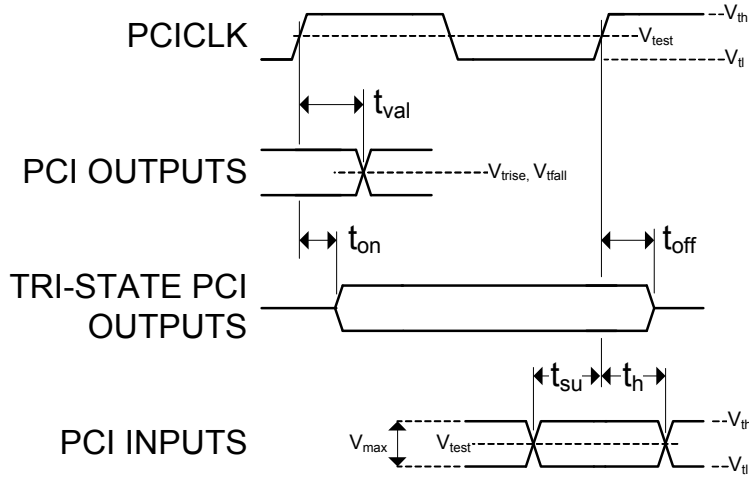

Figure 5.3 PCI I/O Timing

Table 5.10 PCI I/O Timing Measurement Conditions

SYMBOL	VALUE	UNITS
V_{th}	$0.6 \cdot V_{DD33IO}$	V
V_{tl}	$0.2 \cdot V_{DD33IO}$	V
V_{test}	$0.4 \cdot V_{DD33IO}$	V
V_{trise}	$0.285 \cdot V_{DD33IO}$	V
V_{tfall}	$0.615 \cdot V_{DD33IO}$	V
V_{max}	$0.4 \cdot V_{DD33IO}$	V
Input Signal Edge Rate	1	V/ns

Note: Input test is done with $0.1 \cdot V_{DD33IO}$ overdrive. V_{max} specifies the maximum peak-to-peak waveform allowed for testing input timing.

Table 5.11 PCI I/O Timing Values

SYMBOL	DESCRIPTION	MIN	TYP	MAX	UNITS
t_{val}	PCICLK to signal valid delay - bussed signals	2		11	ns
$t_{val(nREQ)}$	PCICLK to nREQ signal valid delay (Note 5.15)	2		12	ns
t_{on}	Float to active delay	2			ns
t_{off}	Active to float delay			28	ns
t_{su}	Input setup time to PCICLK - bussed signals	7			ns
$t_{su(nGNT)}$	nGNT input setup time to PCICLK (Note 5.15)	10			ns
t_h	Input hold time from PCICLK	0			ns
t_{rst}	PCInRST active time after power stable (Note 5.16)	1			ms
$t_{rst-clk}$	PCInRST active time after PCICLK stable (Note 5.16)	100			us
$t_{rst-off}$	Rest active to output float delay (Note 5.16)			40	ns

Note: PCI signal timing is specified with loads detailed in Section 4.2.3.2 of the PCI Local Bus Specification, Rev. 3.0.

Note 5.15 nREQ and nGNT are point-to-point signals and have different timing characteristics than bussed signals. All other signals are bussed.

Note 5.16 PCInRST is asserted and deasserted asynchronously with respect to the PCICLK signal.

5.8 EEPROM Timing

The following specifies the EEPROM timing requirements for LAN9420/LAN9420i:

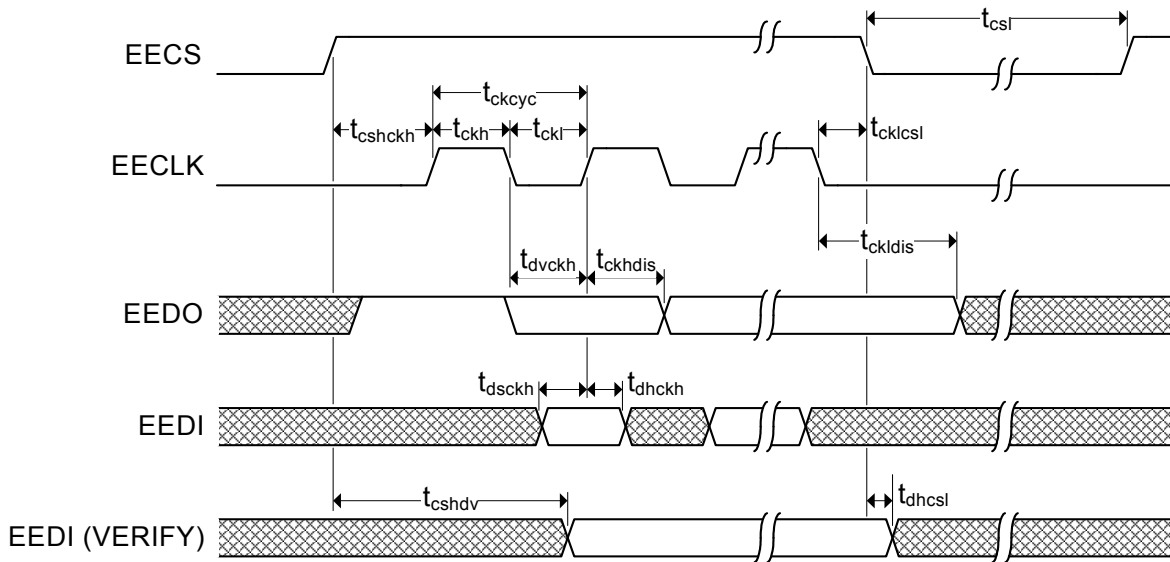

Figure 5.4 EEPROM Timing

Table 5.12 EEPROM Timing Values

SYMBOL	DESCRIPTION	MIN	TYP	MAX	UNITS
t_{ckcyc}	EECLK Cycle time	1110		1130	ns
t_{ckh}	EECLK High time	550		570	ns
t_{ckl}	EECLK Low time	550		570	ns
t_{cshckh}	EECS high before rising edge of EECLK	1070			ns
t_{cklcs1}	EECLK falling edge to EECS low	30			ns
t_{dvckh}	EEDIO valid before rising edge of EECLK (OUTPUT)	550			ns
t_{ckhdis}	EEDIO disable after rising edge EECLK (OUTPUT)	550			ns
t_{dscckh}	EEDIO setup to rising edge of EECLK (INPUT)	90			ns
t_{dhckh}	EEDIO hold after rising edge of EECLK (INPUT)	0			ns
t_{ckldis}	EECLK low to data disable (OUTPUT)	580			ns
t_{cshdv}	EEDIO valid after EECS high (VERIFY)			600	ns
t_{dhcsl}	EEDIO hold after EECS low (VERIFY)	0			ns
t_{csl}	EECS low	1070			ns

5.9 Clock Circuit

LAN9420/LAN9420i can accept either a 25MHz crystal (preferred) or a 25MHz single-ended clock oscillator (+/- 50ppm) input. If the single-ended clock oscillator method is implemented, XO should be left unconnected and XI should be driven with a nominal 0-3.3V clock signal. The input clock duty cycle is 40% minimum, 50% typical and 60% maximum.

It is recommended that a crystal utilizing matching parallel load capacitors be used for the crystal input/output signals (XI/XO). See [Table 5.13](#) for the recommended crystal specifications.

Table 5.13 LAN9420/LAN9420i Crystal Specifications

PARAMETER	SYMBOL	MIN	NOM	MAX	UNITS	NOTES
Crystal Cut	AT, typ					
Crystal Oscillation Mode	Fundamental Mode					
Crystal Calibration Mode	Parallel Resonant Mode					
Frequency	F_{fund}	-	25.000	-	MHz	
Frequency Tolerance @ 25°C	F_{tol}	-	-	+/-50	PPM	Note 5.17
Frequency Stability Over Temp	F_{temp}	-	-	+/-50	PPM	Note 5.17
Frequency Deviation Over Time	F_{age}	-	+/-3 to 5	-	PPM	Note 5.18
Total Allowable PPM Budget		-	-	+/-50	PPM	Note 5.19
Shunt Capacitance	C_O	-	7 typ	-	pF	
Load Capacitance	C_L	-	20 typ	-	pF	
Drive Level	P_W	0.5	-	-	mW	
Equivalent Series Resistance	R_1	-	-	50	Ohm	
Operating Temperature Range		Note 5.20	-	Note 5.21	°C	
LAN9420/LAN9420i XI Pin Capacitance		-	3 typ	-	pF	Note 5.22
LAN9420/LAN9420i XO Pin Capacitance		-	3 typ	-	pF	Note 5.22

Note 5.17 The maximum allowable values for Frequency Tolerance and Frequency Stability are application dependant. Since any particular application must meet the IEEE +/-50 PPM Total PPM Budget, the combination of these two values must be approximately +/-45 PPM (allowing for aging).

Note 5.18 Frequency Deviation Over Time is also referred to as Aging.

Note 5.19 The total deviation for the Transmitter Clock Frequency is specified by IEEE 802.3u as +/- 50 PPM.

Note 5.20 0°C for commercial version, -40°C for industrial version.

Note 5.21 +70°C for commercial version, +85°C for industrial version.

Note 5.22 This number includes the pad, the bond wire and the lead frame. PCB capacitance is not included in this value. The XO/XI pin and PCB capacitance values are required to accurately calculate the value of the two external load capacitors. These two external load capacitors determine the accuracy of the 25.000 MHz frequency.

Chapter 6 Package Outline

6.1 128-VTQFP Package

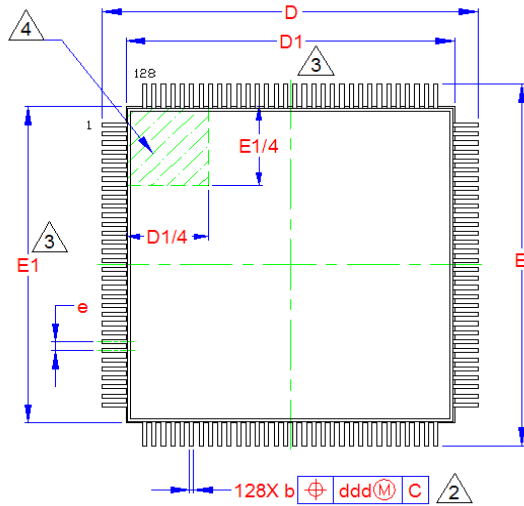

TOP VIEW

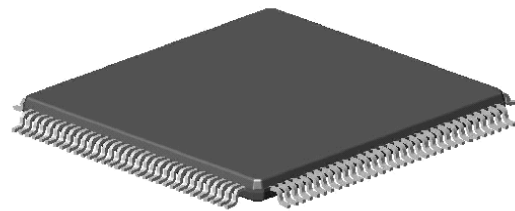

3-D VIEWS

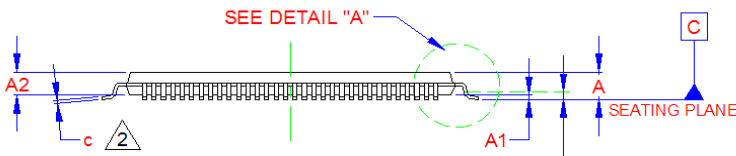

SIDE VIEW

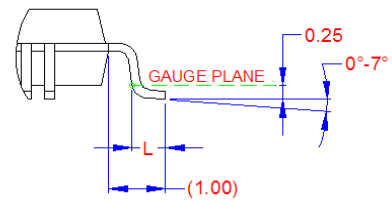

DETAIL "A"

Figure 6.1 LAN9420/LAN9420i 128-VTQFP Package Definition

Table 6.1 LAN9420/LAN9420i 128-VTQFP Dimensions

	MIN	NOMINAL	MAX	REMARKS
A	-	-	1.20	Overall Package Height
A1	0.05	-	0.15	Standoff
A2	0.95	1.00	1.05	Body Thickness
D/E	15.80	16.00	16.20	X/Y Span
D1/E1	13.80	14.00	14.20	X/Y Plastic Body Size
L	0.45	0.60	0.75	Lead Foot Length
b	0.13	0.18	0.23	Lead Width
c	0.09	-	0.20	Lead Foot Thickness
e	0.40 BSC			Lead Pitch
ddd	0.00	-	0.07	True Position Spread
ccc	-	-	0.08	Coplanarity

Notes:

1. All dimensions are in millimeters unless otherwise noted.
2. Dimensions b & c apply to the flat section of the lead foot between 0.10 and 0.25mm from the lead tip. The base metal is exposed at the lead tip.
3. Dimensions D1 and E1 do not include mold protrusions. Maximum allowed protrusion is 0.25mm per side. D1 and E1 are maximum plastic body size dimensions including mold mismatch.
4. The pin 1 identifier may vary, but is always located within the zone indicated.

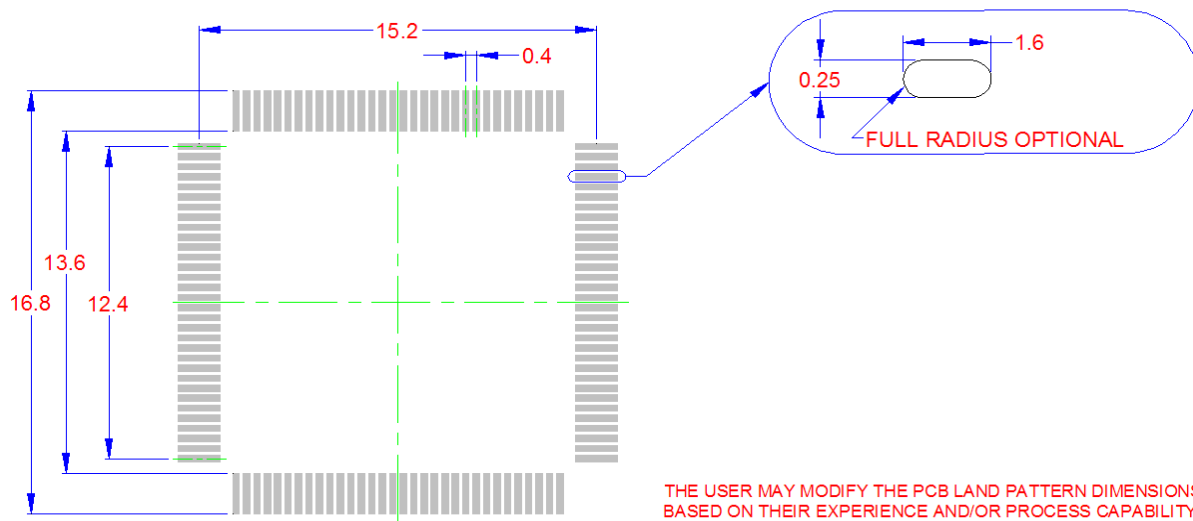

Figure 6.2 LAN9420/LAN9420i 128-VTQFP Recommended PCB Land Pattern

Chapter 7 Datasheet Revision History

Table 7.1 Customer Revision History

REVISION LEVEL & DATE	SECTION/FIGURE/ENTRY	CORRECTION
Rev. 1.6 (07-18-11)	Section 3.5.6.1, "TX Checksum Calculation"	Added note stating TX Checksum calculation should not be used for UDP packets under IPv6.
Rev. 1.5 (04-12-11)	Section 3.7.7, "Enabling Link Status Change (Energy Detect) Wake Events," on page 82	Step #2 corrected from "This is done by setting the INT7 bit in the PHY's Interrupt Source Flag register." to "This is done by setting bit 7 in the PHY's Interrupt Mask register."
	Section 4.3.1, "Bus Mode Register (BUS_MODE)," on page 105	Added note to PBL field description: "PCI bursts are always 16 cycles, regardless of the value in this field."
Rev. 1.4 (12-17-08)	All	Fixed various typos.
	Section 3.7.7, "Enabling Link Status Change (Energy Detect) Wake Events," on page 82	Corrected second sentence of step 3: "This is done by setting the EDPWRDOWN bit in the PHY's Mode Control/Status register."
	Section 4.3.1, "Bus Mode Register (BUS_MODE)," on page 105	Added DBO and BLE bit definitions.
	Table 5.13, "LAN9420/LAN9420i Crystal Specifications," on page 167	Updated max ESR value to 50 Ohms.
Rev. 1.22 (09-23-08)	Added PCI SIG certification logo to cover	
Rev. 1.21 (07-30-08)	Figure 1.2 LAN9420/LAN9420i Internal Block Diagram on page 11	Fixed error: Changed "To option.." text to "(optional)" and moved it to the end of the descriptions.
	Figure 1.2 LAN9420/LAN9420i Internal Block Diagram on page 11	<ul style="list-style-type: none"> - Changed "To option.." text to "(optional)" and moved it to the end of the descriptions. - Removed "To" from "To Ethernet". - Placed bi-directional arrows on EEPROM, GPIO/LED, and PHY blocks.
	Section 4.5.5, "Auto Negotiation Advertisement," on page 141	Changed bits 9 and 15 to RESERVED with a default value of 0b.
	Table 4.10, "Standard PCI Header Registers Supported," on page 151	Added note to default value of Revision ID stating that the default value is dependent on device revision.
	Table 4.10, "Standard PCI Header Registers Supported," on page 151	Changed default values of Min_Gnt and Max_Lat to 02h and 04h, respectively.
	Section 3.5.5.1, "RX Checksum Calculation," on page 63	Changed last line of RX checksum calculation to "checksum = [B1, B0] + C0 + [B3, B2] + C1 + ... + [0, BN] + CN-1"

Table 7.1 Customer Revision History (continued)

REVISION LEVEL & DATE	SECTION/FIGURE/ENTRY	CORRECTION
	Section 3.5.4, "Wakeup Frame Detection," on page 57, Section 4.4.1, "MAC Control Register (MAC_CR)," on page 120	Added note: "When wake-up frame detection is enabled via the WUEN bit of the Wakeup Control and Status Register (WUCSR) , a broadcast wake-up frame will wake-up the device despite the state of the Disable Broadcast (BCAST) bit in the MAC Control Register (MAC_CR) ."
	Section 4.4.12, "Wakeup Control and Status Register (WUCSR)," on page 134	Corrected GUE bit description to state: "...A global unicast frame has the MAC Address [0] bit set to 0."
	Section 5.9, "Clock Circuit," on page 167	Updated Drive Level from 0.5mW to 300uW.
	Section 4.5.5, "Auto Negotiation Advertisement," on page 141	<p>Fixed Pause Operation bit definitions to:</p> <ul style="list-style-type: none"> 00 No PAUSE 01 Symmetric PAUSE 10 Asymmetric PAUSE 11 Advertise support for both symmetric PAUSE and Asymmetric PAUSE <p>Added note stating: When both symmetric PAUSE and asymmetric PAUSE support are advertised (value of 11), the device will only be configured to, at most, one of the two settings upon auto-negotiation completion.</p>

Компания «Life Electronics» занимается поставками электронных компонентов импортного и отечественного производства от производителей и со складов крупных дистрибьюторов Европы, Америки и Азии.

С конца 2013 года компания активно расширяет линейку поставок компонентов по направлению коаксиальный кабель, кварцевые генераторы и конденсаторы (керамические, пленочные, электролитические), за счёт заключения дистрибьюторских договоров

Мы предлагаем:

- Конкурентоспособные цены и скидки постоянным клиентам.
- Специальные условия для постоянных клиентов.
- Подбор аналогов.
- Поставку компонентов в любых объемах, удовлетворяющих вашим потребностям.
- Приемлемые сроки поставки, возможна ускоренная поставка.
- Доставку товара в любую точку России и стран СНГ.
- Комплексную поставку.
- Работу по проектам и поставку образцов.
- Формирование склада под заказчика.
- Сертификаты соответствия на поставляемую продукцию (по желанию клиента).
- Тестирование поставляемой продукции.
- Поставку компонентов, требующих военную и космическую приемку.
- Входной контроль качества.
- Наличие сертификата ISO.

В составе нашей компании организован Конструкторский отдел, призванный помогать разработчикам, и инженерам.

Конструкторский отдел помогает осуществить:

- Регистрацию проекта у производителя компонентов.
- Техническую поддержку проекта.
- Защиту от снятия компонента с производства.
- Оценку стоимости проекта по компонентам.
- Изготовление тестовой платы монтаж и пусконаладочные работы.



Тел: +7 (812) 336 43 04 (многоканальный)

Email: org@lifeelectronics.ru