

THIS DRAWING IS UNPUBLISHED. RELEASED FOR PUBLICATION

© COPYRIGHT - By - ALL RIGHTS RESERVED.

PROJECT	PRJ-16-000909157
PART NO.	X-2308340-X
DESCRIPTION	FULL METAL HOODS SIZE 1
CUSTOMER	GENERAL MARKET

REVISIONS					
P	LTR	DESCRIPTION	DATE	DWN	APVD
	A1	REVISED PER ECR-16-013123	19SEP2016	KK	GG

D

C

B

A

D

C

B

A

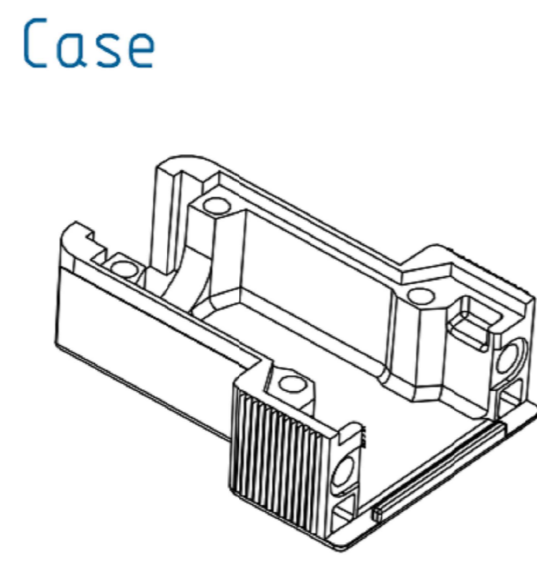
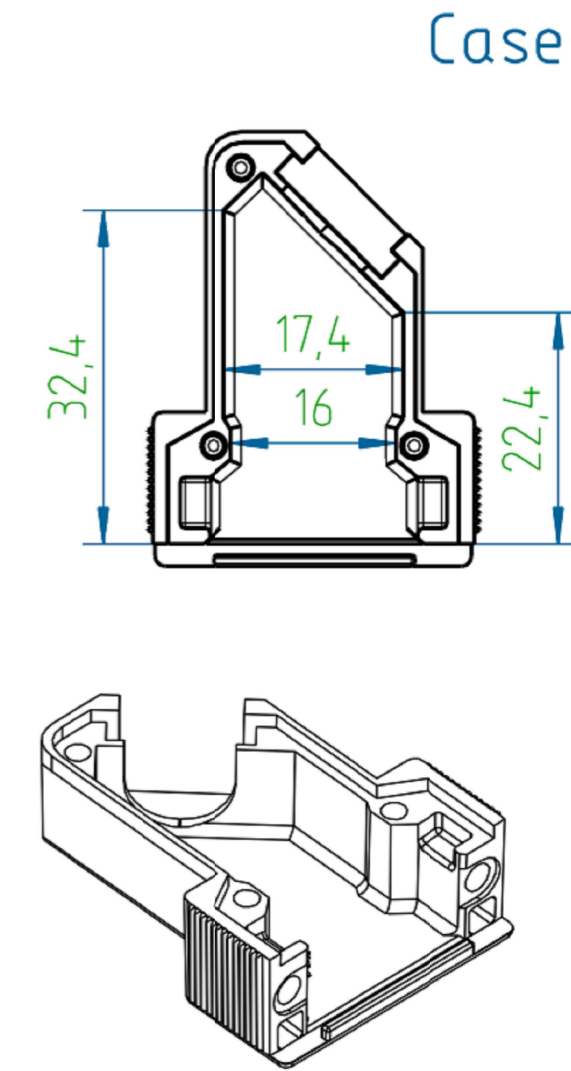
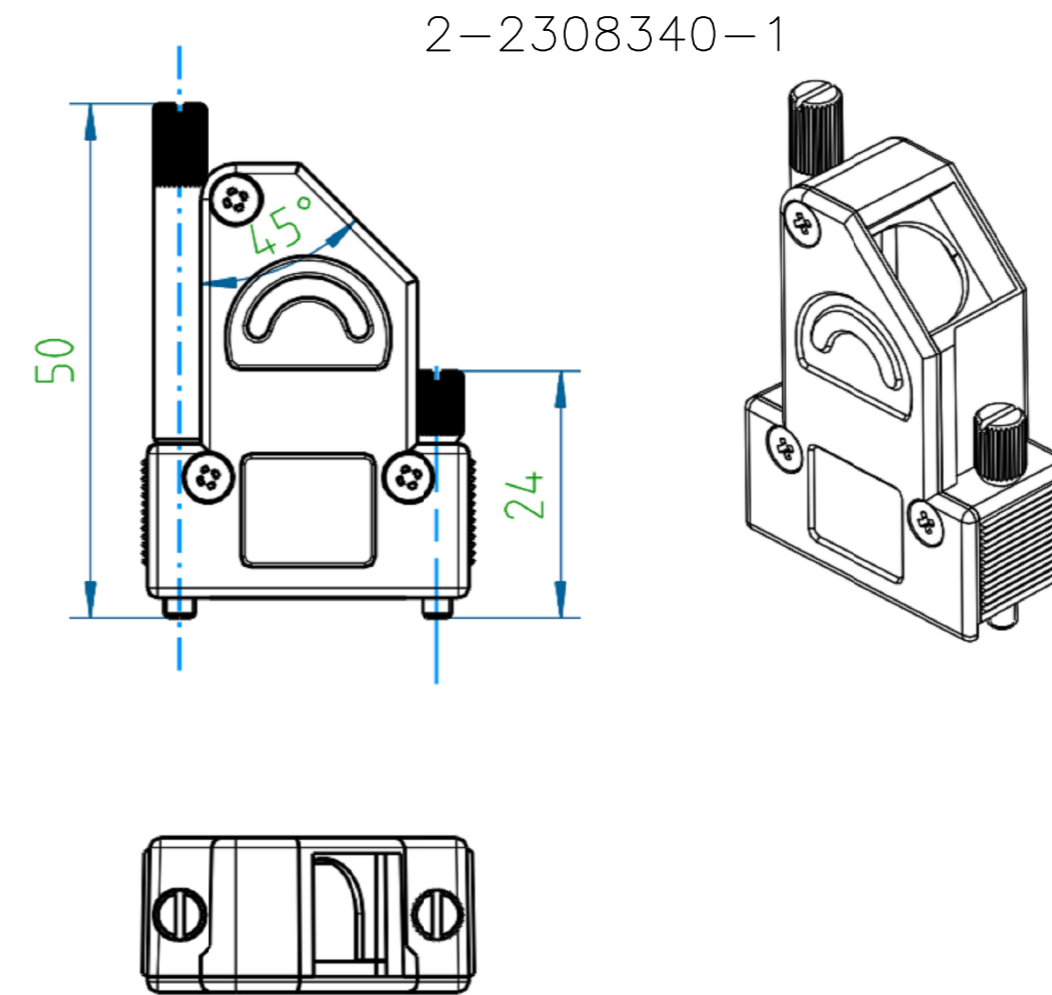
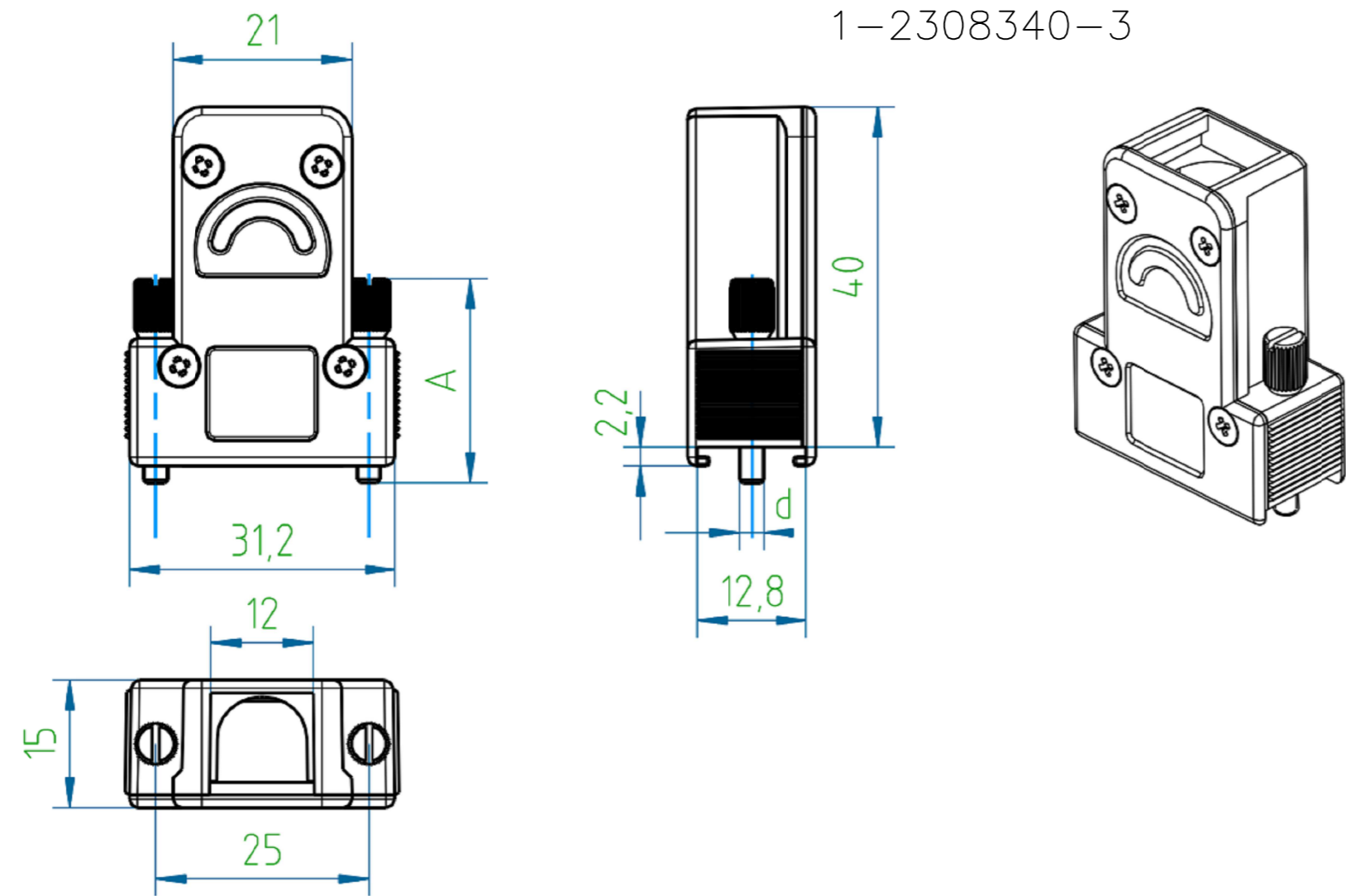

NOTES:

- FINISH:
1-2308340-1 TO 2-2308340-2 - CASE RAW.
2-2308340-3 TO 3-2308340-4 - CASE NICKEL-PLATED.
- LOCKING SCREWS: NICKEL-PLATED
OTHER SCREWS: ZINC-PLATED
- TEMPERATURE RANGE: -40°C TO +90°C
- CABLE DIAMETER WITH EXTERNAL DIAMETER CABLE CLAMP: 4-14 mm.
- STRAND DIAMETER OF CRIMP FLANGE: 2.7-8.7 mm.

THIS DRAWING IS A CONTROLLED DOCUMENT.		DWN KIRAN K 02AUG2016	TE Connectivity	
DIMENSIONS: mm		CHK GUNASEKHAR G 02AUG2016		
TOLERANCES UNLESS OTHERWISE SPECIFIED: DIN ISO 2768-m DIN 16901 130B		APVD GUNASEKHAR G 02AUG2016	PRODUCT SPEC	RESTRICTED TO
		APPLICATION SPEC	SCALE	REV
MATERIAL		WEIGHT	A2 00779 G=2308340	A1
		CUSTOMER DRAWING	SCALE NTS	SHEET 1 of 2

THIS DRAWING IS UNPUBLISHED. RELEASED FOR PUBLICATION
 © COPYRIGHT - By - ALL RIGHTS RESERVED.

REVISIONS					
P	LTR	DESCRIPTION	DATE	DWN	APVD
-	-	SEE SHEET 1	-	-	-

PART NO.	DESCRIPTION	PART NO.	DESCRIPTION	SUB-PART NO.	DESCRIPTION	S OVER	M3	WEIGHT, g
-	-	2-2308340-2	FULL METAL HOODS SIZE1-12	1-2308334-6	1-2308334-4	LOCKING SCREW (M3 LONG KNURLED)	M3	43
-	-	2-2308340-1	FULL METAL HOODS SIZE1-11	1-2308334-5	1-2308334-3	LOCKING SCREW (4-40 UNC LONG KNURLED)	4-40 UNC	43
1-2308340-6	FULL METAL HOODS SIZE1-6	-	-	1-2308334-6	LOCKING SCREW (M3 LONG KNURLED)	50.0	M3	47
1-2308340-5	FULL METAL HOODS SIZE1-5	-	-	1-2308334-5	LOCKING SCREW (4-40 UNC LONG KNURLED)	50.0	4-40 UNC	47
1-2308340-4	FULL METAL HOODS SIZE1-4	2-2308340-0	FULL METAL HOODS SIZE1-10	1-2308334-4	LOCKING SCREW (M3 SHORT KNURLED)	24.0	M3	39
1-2308340-3	FULL METAL HOODS SIZE1-3	1-2308340-9	FULL METAL HOODS SIZE1-9	1-2308334-3	LOCKING SCREW (4-40 UNC SHORT KNURLED)	24.0	4-40 UNC	39
1-2308340-2	FULL METAL HOODS SIZE1-2	1-2308340-8	FULL METAL HOODS SIZE1-8	1-2308334-2	LOCKING SCREW (M3 W/SPRING WASHER)	20.7	M3	38
1-2308340-1	FULL METAL HOODS SIZE1-1	1-2308340-7	FULL METAL HOODS SIZE1-7	1-2308334-1	LOCKING SCREW (4-40 UNC W/SPRING WASHER)	20.7	4-40 UNC	38
VERSION 180*		VERSION 135*		LOCKING SCREWS		A	d	WEIGHT, g
PART NO. (CASE RAW)								

PART NO.	DESCRIPTION	PART NO.	DESCRIPTION	SUB-PART NO.	DESCRIPTION	S OVER	M3	WEIGHT, g
-	-	3-2308340-4	FULL METAL HOODS SIZE1-24	1-2308334-6	1-2308334-4	LOCKING SCREW (M3 LONG KNURLED)	M3	43
-	-	3-2308340-3	FULL METAL HOODS SIZE1-23	1-2308334-5	1-2308334-3	LOCKING SCREW (4-40 UNC LONG KNURLED)	4-40 UNC	43
2-2308340-8	FULL METAL HOODS SIZE1-18	-	-	1-2308334-6	LOCKING SCREW (M3 LONG KNURLED)	50.0	M3	47
2-2308340-7	FULL METAL HOODS SIZE1-17	-	-	1-2308334-5	LOCKING SCREW (4-40 UNC LONG KNURLED)	50.0	4-40 UNC	47
2-2308340-6	FULL METAL HOODS SIZE1-16	3-2308340-2	FULL METAL HOODS SIZE1-22	1-2308334-4	LOCKING SCREW (M3 SHORT KNURLED)	24.0	M3	39
2-2308340-5	FULL METAL HOODS SIZE1-15	3-2308340-1	FULL METAL HOODS SIZE1-21	1-2308334-3	LOCKING SCREW (4-40 UNC SHORT KNURLED)	24.0	4-40 UNC	39
2-2308340-4	FULL METAL HOODS SIZE1-14	3-2308340-0	FULL METAL HOODS SIZE1-20	1-2308334-2	LOCKING SCREW (M3 W/SPRING WASHER)	20.7	M3	38
2-2308340-3	FULL METAL HOODS SIZE1-13	2-2308340-9	FULL METAL HOODS SIZE1-19	1-2308334-1	LOCKING SCREW (4-40 UNC W/SPRING WASHER)	20.7	4-40 UNC	38
VERSION 180*		VERSION 135*		LOCKING SCREWS		A	d	WEIGHT, g
PART NO. (CASE Ni-PLATED)								

NOTE:

- * CRIMP FLANGE PN *-2308349-* TO BE ORDERED SEPARATELY.
- * CRIMP BARREL TO BE USED IN COMBINATION WITH THE FLANGE PN *-2308350-* TO BE ORDERED SEPARATELY.
- * CABLE CLAMP SCREW VERSION PN *-2308272-* TO BE ORDERED SEPARATELY.



CRIMP FLANGE

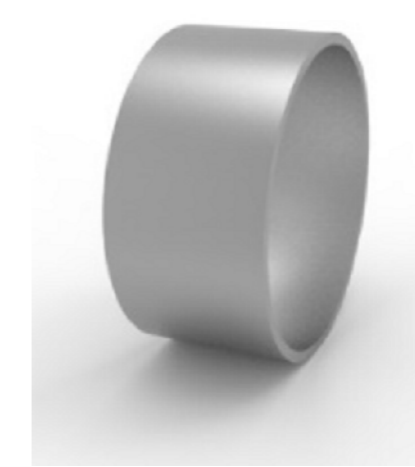

CRIMP BARREL

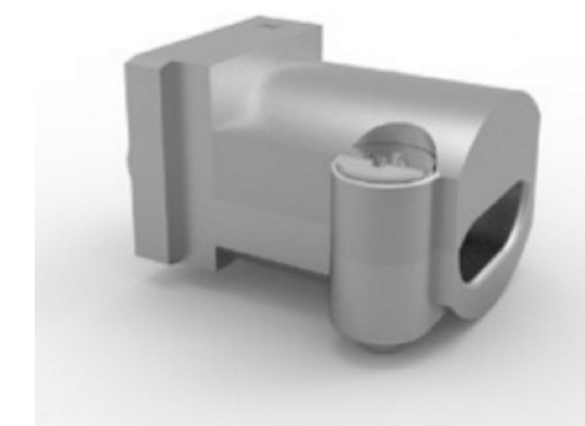

CABLE CLAMP

THIS DRAWING IS A CONTROLLED DOCUMENT.		DWN KIRAN K 02AUG2016		
DIMENSIONS: mm		CHK GUNASEKHAR G 02AUG2016		
		TOLERANCES UNLESS OTHERWISE SPECIFIED: DIN ISO 2768-m DIN 16901 130B		NAME GUNASEKHAR G 02AUG2016
MATERIAL		PRODUCT SPEC		SIZE A2
FINISH		APPLICATION SPEC		CAGE CODE 00779
		WEIGHT		DRAWING NO G=2308340
		CUSTOMER DRAWING		RESTRICTED TO -
		SCALE NTS		SHEET 2 of 2
				REV A1

Компания «Life Electronics» занимается поставками электронных компонентов импортного и отечественного производства от производителей и со складов крупных дистрибьюторов Европы, Америки и Азии.

С конца 2013 года компания активно расширяет линейку поставок компонентов по направлению коаксиальный кабель, кварцевые генераторы и конденсаторы (керамические, пленочные, электролитические), за счёт заключения дистрибьюторских договоров

Мы предлагаем:

- Конкурентоспособные цены и скидки постоянным клиентам.
- Специальные условия для постоянных клиентов.
- Подбор аналогов.
- Поставку компонентов в любых объемах, удовлетворяющих вашим потребностям.
- Приемлемые сроки поставки, возможна ускоренная поставка.
- Доставку товара в любую точку России и стран СНГ.
- Комплексную поставку.
- Работу по проектам и поставку образцов.
- Формирование склада под заказчика.
- Сертификаты соответствия на поставляемую продукцию (по желанию клиента).
- Тестирование поставляемой продукции.
- Поставку компонентов, требующих военную и космическую приемку.
- Входной контроль качества.
- Наличие сертификата ISO.

В составе нашей компании организован Конструкторский отдел, призванный помогать разработчикам, и инженерам.

Конструкторский отдел помогает осуществить:

- Регистрацию проекта у производителя компонентов.
- Техническую поддержку проекта.
- Защиту от снятия компонента с производства.
- Оценку стоимости проекта по компонентам.
- Изготовление тестовой платы монтаж и пусконаладочные работы.



Тел: +7 (812) 336 43 04 (многоканальный)

Email: org@lifeelectronics.ru