

PLEASE CHECK WWW.MOLEX.COM FOR LATEST PART INFORMATION

Part Number: [0528081370](#)
Status: **Active**
Overview:
Description: 1.00mm (.039") Pitch FFC/FPC Connector, SMT, Vertical, Non-ZIF Receptacle, 13 Circuits, Lead-free

Agency Certification

UL E29179

General

Product Family FFC/FPC Connectors
 Series 52808
 Overview ffc_fpc_smt
 Product Name N/A

Physical

Circuits (Loaded) 13
 Circuits (maximum) 13
 Color - Resin Natural
 Contact Position N/A
 Durability (mating cycles max) 10
 Entry Angle N/A
 Flammability 94V-0
 Mated Height (in) 0.199 In
 Mated Height (mm) 5.05 mm
 Material - Metal Phosphor Bronze
 Material - Plating Mating Tin-Bismuth
 Material - Plating Termination Tin-Bismuth
 Material - Resin High Temperature Thermoplastic
 Number of Rows 1
 Orientation Vertical
 PCB Locator No
 PCB Retention None
 Packaging Type Embossed Tape on Reel
 Pitch - Mating Interface (in) 0.039 In
 Pitch - Mating Interface (mm) 1.00 mm
 Pitch - Term. Interface (in) 0.039 In
 Pitch - Term. Interface (mm) 1.00 mm
 Plating min: Mating (µin) 40
 Plating min: Mating (µm) 1
 Plating min: Termination (µin) 40
 Plating min: Termination (µm) 1
 Polarized to PCB No
 Stackable No
 Surface Mount Compatible (SMC) Yes
 Temperature Range - Operating -20°C to +80°C
 Termination Interface: Style Surface Mount
 Wire/Cable Type FFC/FPC

Electrical

Current - Maximum per Contact 0.5A
 Voltage - Maximum 125V AC (RMS)/DC

Material Info

Reference - Drawing Numbers

Packaging Specification SPK-52808-001

EU RoHS
ELV and RoHS
Compliant
REACH SVHC
Contains SVHC: No
Halogen-Free
Status
Not Reviewed

China RoHS



Need more information on product environmental compliance?

Email productcompliance@molex.com
 For a multiple part number RoHS Certificate of Compliance, [click here](#)

Please visit the [Contact Us](#) section for any non-product compliance questions.

Search Parts in this Series
 52808Series

Product Specification

Sales Drawing

PS-52808-004, RPS-52808-039, RPS-52808-044,
RPS-52808-045, RPS-52808-047, RPS-52808-048,
RPS-52808-049
SD-52808-027, SD-52808-028

This document was generated on 06/05/2010

PLEASE CHECK WWW.MOLEX.COM FOR LATEST PART INFORMATION

10 9 8 7 6 5 4 3 2 1

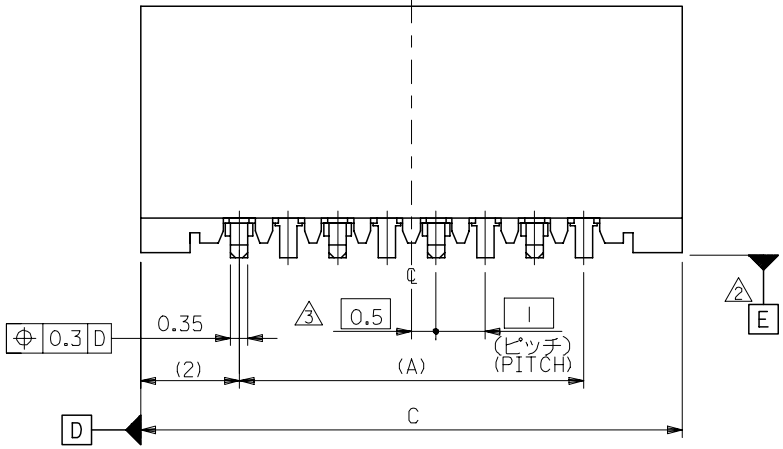
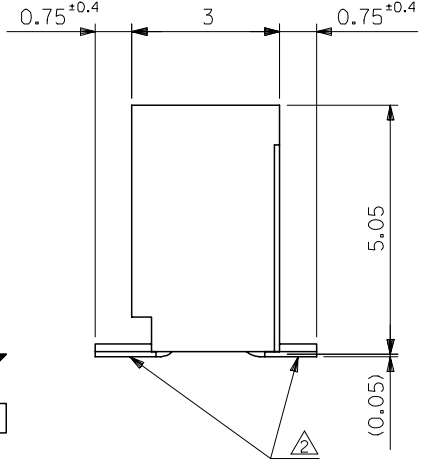
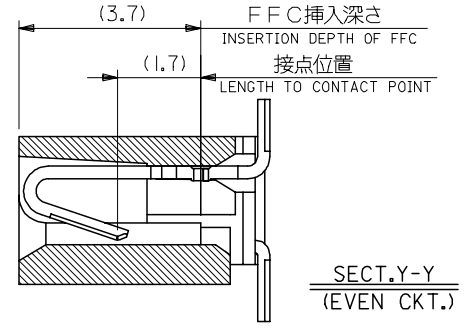
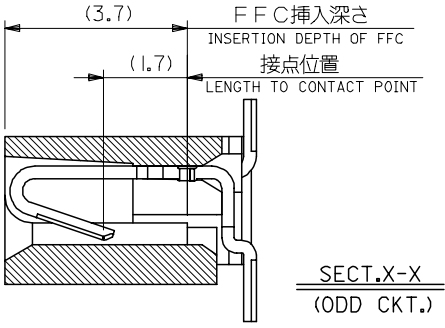
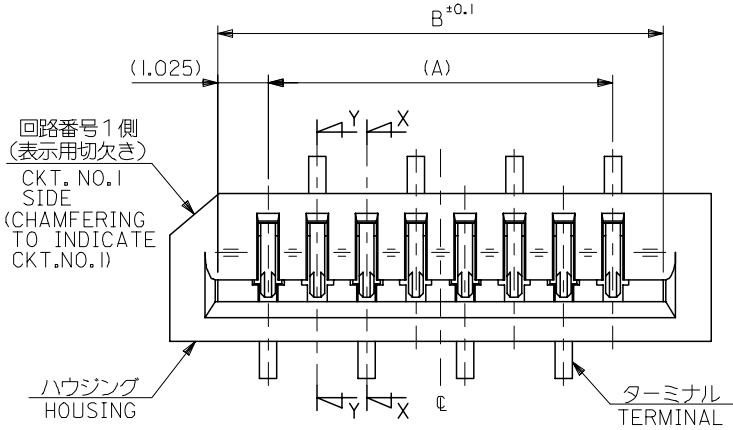

33	31.05	29	52808-3019	30
32	30.05	28	-2919	29
31	29.05	27	-2819	28
30	28.05	26	-2719	27
29	27.05	25	-2619	26
28	26.05	24	-2519	25
27	25.05	23	-2419	24
26	24.05	22	-2319	23
25	23.05	21	-2219	22
24	22.05	20	-2119	21
23	21.05	19	-2019	20
22	20.05	18	-1919	19
21	19.05	17	-1819	18
20	18.05	16	-1719	17
19	17.05	15	-1619	16
18	16.05	14	-1519	15
17	15.05	13	-1419	14
16	14.05	12	-1319	13
15	13.05	11	-1219	12
14	12.05	10	-1119	11
13	11.05	9	-1019	10
12	10.05	8	-0919	9
11	9.05	7	-0819	8
10	8.05	6	-0719	7
9	7.05	5	-0619	6
8	6.05	4	-0519	5
7	5.05	3	52808-0419	4

注記 NOTES:

- 使用材料 MATERIAL
 ハウジング: PPS, UL94V-0 HOUSING : PPS, UL94V-0
 ターミナル: リン青銅 ($\epsilon=0.25$) TERMINAL : PHOSPHOR BRONZE
 メッキ: ニッケル下地鍍ビスマスメッキ PLATING : TIN-BISMUTH OVER NICKEL
- 基準面 [E] からのソルダーテールの半田付け面のズレ量は、
 上方向に0.1 MAX. 下方向0.15 MAX. とする。
 MISALIGNMENT OF SOLDER TAIL FROM [E]
 : UPPER DIRECTION 0.1 MAX. , LOWER DIRECTION 0.15 MAX.
- 偶数極に適用。
 APPLY FOR EVEN CKT.
- 本製品は52808-**-10の鉛フリー品である。
 THIS PRODUCT IS LEAD FREE OF 52808-**-10

REVISED EC NO: J2006-1497 DRW: NABE1 2005/11/04 CHK: KYOYODA 2005/11/07 APP: NUKITA 2005/11/11	GENERAL TOLERANCES (UNLESS SPECIFIED)	DIMENSION STYLE MM ONLY	SCALE ---	DESIGN UNITS METRIC	THIRD ANGLE PROJECTION
	10 UNDER ±0.2	DRAWN BY M. NABE1	DATE '04/02/19	TITLE 1.0 FFC CONN. NON ZIF SMT. ST. -LEAD FREE-	
	10 OVER 30 UNDER ±0.25	CHECKED BY M. SASAO	DATE '04/02/19	MOLEX INCORPORATED	
	30 OVER ±0.3	APPROVED BY M. SASAO	DATE '04/02/19	DOCUMENT NO. SD-52808-027	SHEET NO. 1 OF 1
ANGULAR ±3 °	MATERIAL NO. SEE CHART		THIS DRAWING CONTAINS INFORMATION THAT IS PROPRIETARY TO MOLEX INCORPORATED AND SHOULD NOT BE USED WITHOUT WRITTEN PERMISSION		
DRAFT WHERE APPLICABLE MUST REMAIN WITHIN DIMENSIONS	SIZE A3				

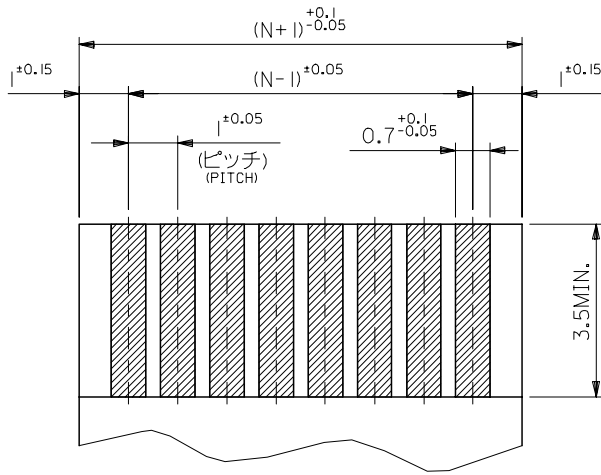

(仕上がり厚さ) 0.3 ± 0.03
THICKNESS
適合FPC推奨寸法
APPLICABLE FPC
RECOMMENDED DIMENSION.

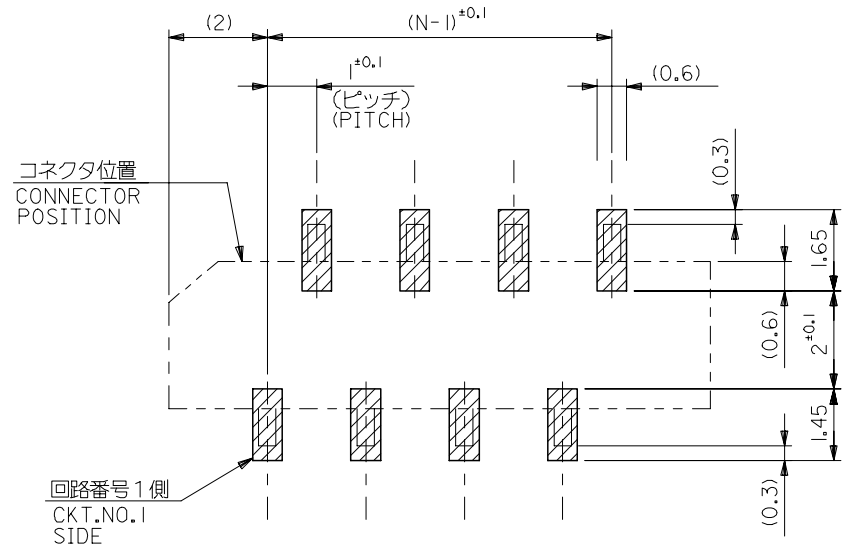

参考基板レイアウト (マウント面)
RECOMMENDED P.C.BOARD
PATTERN DIMENSION. (REF.)
(MOUNTING AREA)

FPCについて:

- 打抜き方向は、導体側から補強板側を推奨いたします。
- 補強フィルム材質は、ポリイミドを推奨いたします。
- 接着剤は、熱硬化接着剤を推奨いたします。

ABOUT FPC:

RECOMMENDED PUNCHER DIRECTION: FROM CONDUCTOR SIDE TO STIFFENER BOARD SIDE.

RECOMMENDED MATERIAL:
STIFFENER FILM: POLYIMIDE
BONDING AGENT: THERMOSETTING BONDING AGENT

REVISED EC NO: J2006-1497 DRW: NABEI 2005/11/04 CHK: KTOYODA 2005/11/07 APPR: NUKITA 2005/11/11 A	GENERAL TOLERANCES (UNLESS SPECIFIED)		DIMENSION STYLE MM ONLY		SCALE ---	DESIGN UNITS METRIC	THIRD ANGLE PROJECTION	
	10 UNDER	±0.2	DRAWN BY M. NABEI	DATE '04/02/19	TITLE 1.0 FFC CONN. NON ZIF SMT. ST. -LEAD FREE-			
	10 ⁰ OVER 30 UNDER	±0.25	CHECKED BY M. SASAO	DATE '04/02/19	MOLEX INCORPORATED DOCUMENT NO. SD-52808-027 SHEET NO. 2 OF 2			
	30 ⁰ OVER	±0.3	APPROVED BY M. SASAO	DATE '04/02/19				
	ANGULAR	±3 °	MATERIAL NO. SEE CHART					
DRAFT WHERE APPLICABLE MUST REMAIN WITHIN DIMENSIONS		SIZE A3	THIS DRAWING CONTAINS INFORMATION THAT IS PROPRIETARY TO MOLEX INCORPORATED AND SHOULD NOT BE USED WITHOUT WRITTEN PERMISSION					

引き出し方向
PULL OUT

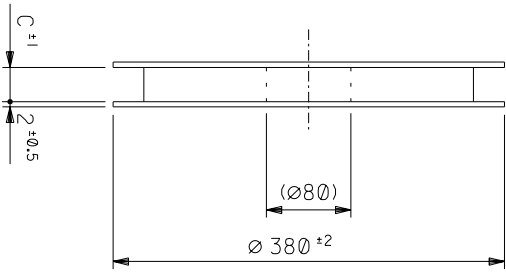
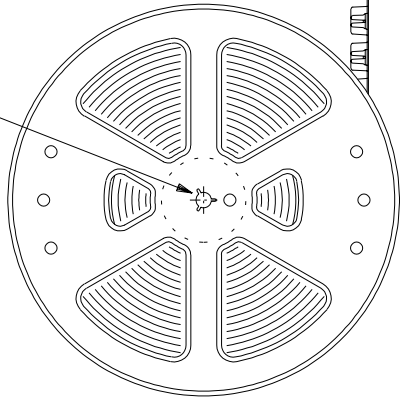

引き出し方向
PULL OUT DIRECTION

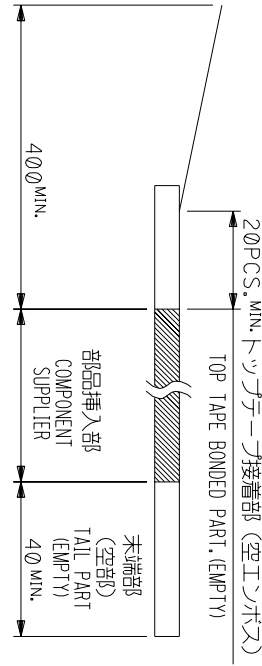

NOTES

- 製品詳細寸法については図面 SD-52808-027 を参照下さい。
RE DETAILED DIMENSION, SEE SD-52808-027
- 梱包数量: 1000個/リール
NUMBER OF CONNECTORS: 1000PCS/REEL
- リールテープ長さ LEAD TAPE LENGTH
20PCS. MIN. トッパテープ接着部 (空エンプティ)

4. トッパテープの剥離強度: 0.1 ~ 1.3N (10 ~ 130gf)
(剥離方向は下図参照)
尚、本規格値は出荷時に適用。(但し、輸送時に剥離が発生しないこと。)
PEELING OFF FORCE OF TOP TAPE: 0.1 ~ 1.3N (10 ~ 130gf)
(PEELING DIRECTION AS SHOWN IN FOLLOWING FIG.)
THIS REQUIREMENT SHOULD BE APPLIED AT SHIPMENT.
PEEL OFF SHOULD NOT BE ALLOWED, DURING TRANSPORTATION.

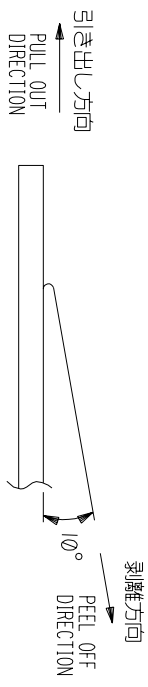

- 材料(MATERIAL)
キャリアテープ(CARRIER TAPE): ポリプロピレン(POLYPROPYLENE)
トッパテープ(TOPTAPE): PET, PE, PEF
リール(REEF): ポリスチレン(PS) <リサイクル材を含む>
POLYSTYRENE(PS) RECYCLE MATERIAL CONTAINED>
- 本製品は52808-**-90の鉛フリー品である。
THIS PRODUCT IS LEAD FREE OF 52808-**-90

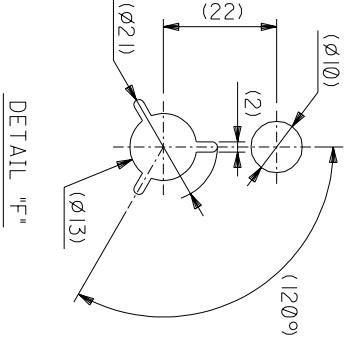

DETAIL "F"

角度 ANGLE	±3°
30以上	±0.3
10以下	±0.25
10未満	±0.2
10 UNDER	
GENERAL TOLERANCES	

記号	0	0	0	0	0	0	0	0	0
TR	TR	TR	TR	TR	TR	TR	TR	TR	TR
REVISION RECORD	DR. CHK.	DATE	DATE	DATE	DATE	DATE	DATE	DATE	DATE
変更内容	DR. CHK.	DATE	DATE	DATE	DATE	DATE	DATE	DATE	DATE
材料 MATERIAL	注記参照 SEE NOTES	仕上がり FINISH	#	適用電線範囲 WIRE RANGE	#	検査外径 INS. RANGE	#	材料 MATERIAL	注記参照 SEE NOTES
REVISION RECORD	DR. CHK.	DATE	DATE	DATE	DATE	DATE	DATE	DATE	DATE
REVISE ONLY ON CAD SYSTEM	MOLEX JAPAN CO., LTD. 日本モリス株式会社	TITLE 名称	I.0 FFC Conn NON ZIF SMT ST Embstd PKG -LEAD FREE-	DRAWN BY	M.NABEI	CHK'D BY	M.SASAO	SCALE	#
REVISE ONLY ON CAD SYSTEM	MOLEX JAPAN CO., LTD. 日本モリス株式会社	TITLE 名称	I.0 FFC Conn NON ZIF SMT ST Embstd PKG -LEAD FREE-	APP'D BY	M.SASAO	SCALE	#	DWG. NO.	SD-52808-028
REVISE ONLY ON CAD SYSTEM	MOLEX JAPAN CO., LTD. 日本モリス株式会社	TITLE 名称	I.0 FFC Conn NON ZIF SMT ST Embstd PKG -LEAD FREE-	DATE		DATE		(SHEET 1 OF 6) REV	0
REVISE ONLY ON CAD SYSTEM	MOLEX JAPAN CO., LTD. 日本モリス株式会社	TITLE 名称	I.0 FFC Conn NON ZIF SMT ST Embstd PKG -LEAD FREE-	DATE		DATE			

52808-**-70
MODEL NO.

THIS DRAWING CONTAINS INFORMATION THAT IS PROPRIETARY TO MOLEX/JAPAN AND SHOULD NOT BE USED WITHOUT WRITTEN PERMISSION
本図面は日本モリス(株)の所有する権利を有するため、当社の許可なく複製を禁止する。

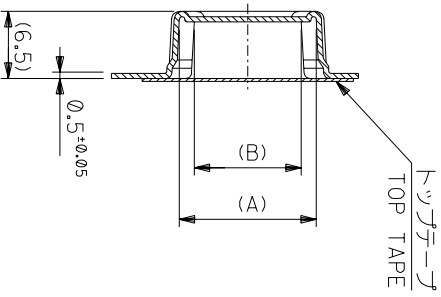

SECT:Y-Y

24mm幅キャリアテープ
24mm WIDTH CARRIER TAPE

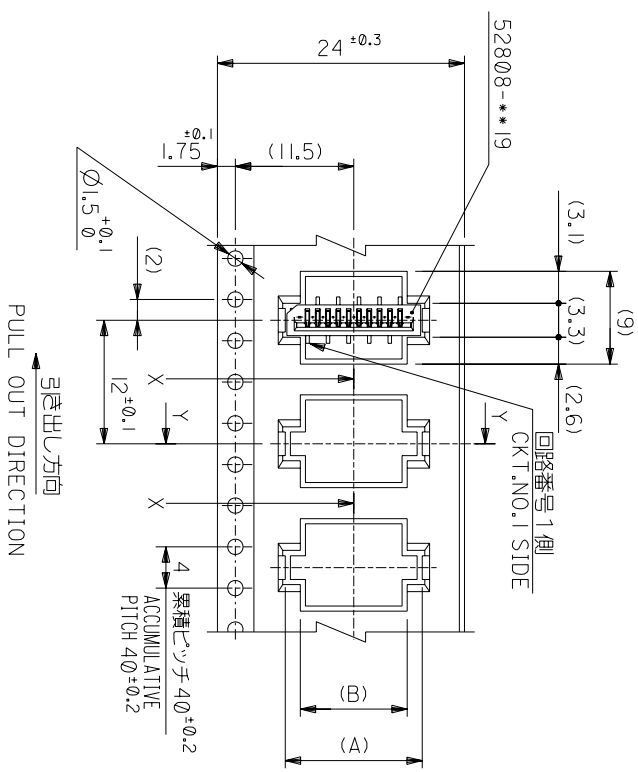

引き出し方向
PULL OUT DIRECTION

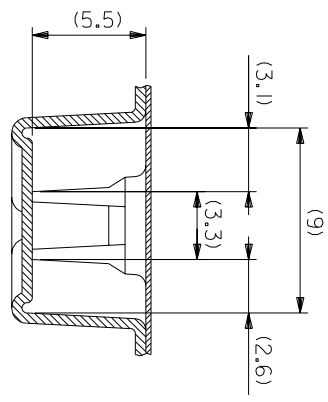

SECT:X-X
(SCALE:4-1)

MODEL NO.	52808-**70	キャリアテープ幅 CARRIER TAPE WIDTH	C	(B)	(A)	種数 CKT.
	24	25.5	10.4	13.3	52808-1070	10
			9.4	12.3	52808-0970	9
			8.4	11.3	52808-0870	8
			7.4	10.3	52808-0770	7
			6.4	9.3	52808-0670	6

材料 MATERIAL SHEET 10F 6 参照
REFER TO SHEET 10F 6

仕上げ FINISH #

適用電線範囲 WIRE RANGE #

標準外径 INS. RANGE #

DRAWN BY 04/02/19 CHK'D BY 04/02/19
M.NABEI M.SASAO

尺度 SCALE #

DWG. NO. SD-52808-028 (SHEET 3 OF 6) REV 0

角度 ANGLE	3°
30以上	1.2
10以下	1.25
10 UNDER	1.25
30 UNDER	1.2
10 UNDER	1.2

記号	0	新規作成 (12004-2528)	DR-CHK.	日付	04/02/19
変更内容	REVISION	変更内容	DR-CHK.	日付	04/02/19
一般公差	GENERAL TOLERANCES				

THIS DRAWING CONTAINS INFORMATION THAT IS PROPRIETARY TO MOLEX(JAPAN) AND SHOULD NOT BE USED WITHOUT WRITTEN PERMISSION
本図面は日本モリス(株)の所有する権利を有するもので 当社の許可なく複製を禁止する。

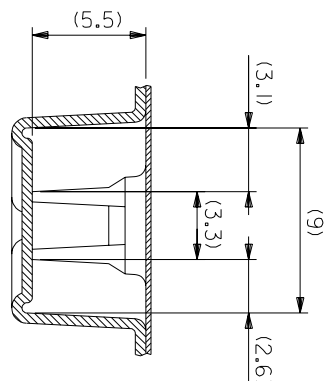
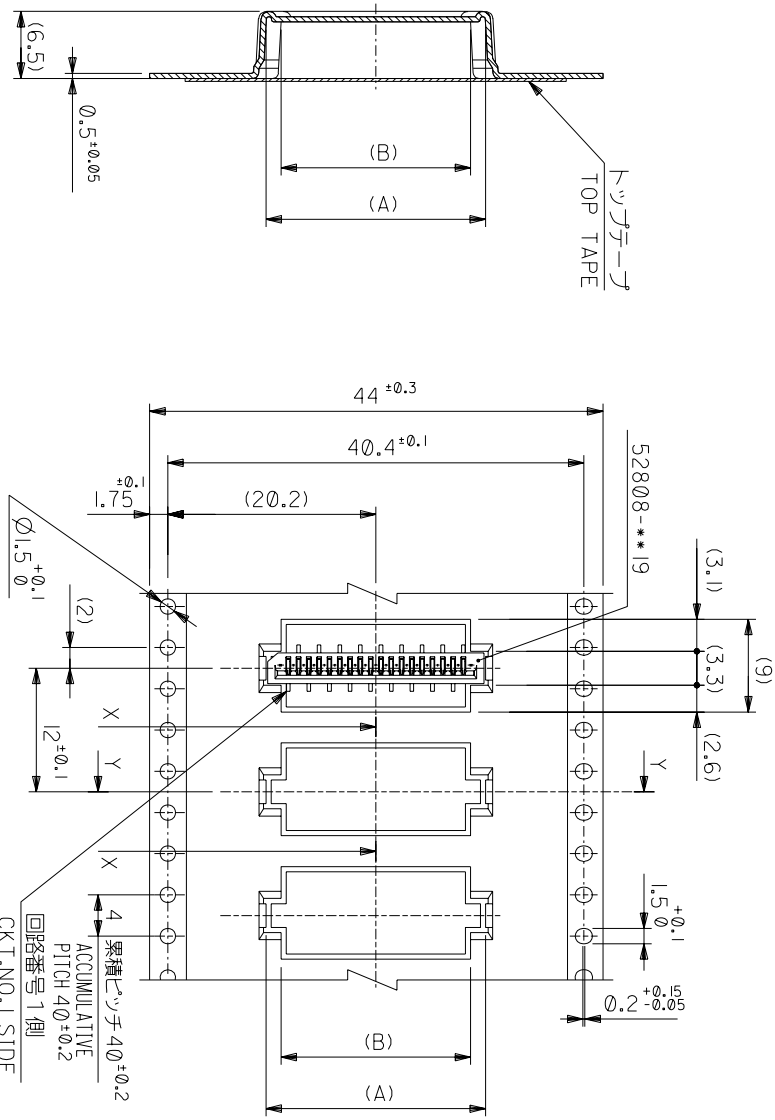

44mm幅キリテープ
44mm WIDTH CARRIER TAPE

SECT:Y-Y

引き出し方向
PULL OUT DIRECTION

MODEL NO.	キャリアテープ幅 CARRIER TAPE WIDTH	C	(B)	(A)	種数 CKT.
52808-**70	44	45.5			16
					17
					18
					19
					20
					21
					22
					23
					24
					25
					26
					27
					28

材料 MATERIAL	キャリアテープ幅 CARRIER TAPE WIDTH	44	45.5		
参照シート REFER TO SHEET	SHEET 1 OF 6				
仕上げ FINISH	—				
適用電線範囲 WIRE RANGE	—				
被覆外径 INS. RANGE	—				
製作者 DRAWN BY	04/02/19	CHK'D BY	04/02/19		
承認者 M.NABEI		尺 SCALE	M.SASAO		
記号 DR.	0	日付 DATE	M.SASAO		
変更内容 REVISION	0	変更内容 REVISION	0		
一般公差 GENERAL TOLERANCES	角 ANGLE	±0.2	±0.2		
	30 以上	±0.2	±0.2		
	10 以下	±0.15	±0.15		
	未 満	±0.1	±0.1		

角
ANGLE

30
以上

10
以下

未
満

±0.2

±0.15

±0.1

製
作者

04/02/19

承認
者

M.NABEI

尺
SCALE

M.SASAO

日
付

DATE

M.SASAO

変
更
内
容

REVISION

0

変
更
内
容

REVISION

0

一
般
公
差

GENERAL TOLERANCES

角
ANGLE

±0.2

±0.2

±0.15

±0.15

±0.1

±0.1

THIS DRAWING CONTAINS INFORMATION THAT IS PROPRIETARY TO MOLEX(JAPAN) AND SHOULD NOT BE USED WITHOUT WRITTEN PERMISSION

本図面は日本モリス(株)の所有する情報を含むもので 当社の許可なく複製を禁止する。

Компания «Life Electronics» занимается поставками электронных компонентов импортного и отечественного производства от производителей и со складов крупных дистрибьюторов Европы, Америки и Азии.

С конца 2013 года компания активно расширяет линейку поставок компонентов по направлению коаксиальный кабель, кварцевые генераторы и конденсаторы (керамические, пленочные, электролитические), за счёт заключения дистрибьюторских договоров

Мы предлагаем:

- Конкуренеспособные цены и скидки постоянным клиентам.
- Специальные условия для постоянных клиентов.
- Подбор аналогов.
- Поставку компонентов в любых объемах, удовлетворяющих вашим потребностям.
- Приемлемые сроки поставки, возможна ускоренная поставка.
- Доставку товара в любую точку России и стран СНГ.
- Комплексную поставку.
- Работу по проектам и поставку образцов.
- Формирование склада под заказчика.
- Сертификаты соответствия на поставляемую продукцию (по желанию клиента).
- Тестирование поставляемой продукции.
- Поставку компонентов, требующих военную и космическую приемку.
- Входной контроль качества.
- Наличие сертификата ISO.

В составе нашей компании организован Конструкторский отдел, призванный помогать разработчикам, и инженерам.

Конструкторский отдел помогает осуществить:

- Регистрацию проекта у производителя компонентов.
- Техническую поддержку проекта.
- Защиту от снятия компонента с производства.
- Оценку стоимости проекта по компонентам.
- Изготовление тестовой платы монтаж и пусконаладочные работы.



Тел: +7 (812) 336 43 04 (многоканальный)

Email: org@lifeelectronics.ru