



OpenIMU300RI

Rugged Open-Source IMU with CAN Output



The ACEINNA OpenIMU300RI is an easy-to-use high-performance 9-DOF open inertial platform packaged in a rugged sealed over-molded plastic housing. The OpenIMU300RI features a precision MEMS 3-Axis Accelerometer, low-drift MEMS 3-Axis Rate Gyro, and 3-Axis AMR Magnetometer. The processing power is provided by a 168MHz ARM M4 CPU with a Floating Point Unit. The OpenIMU300RI runs the OpenIMU open-source stack that includes an optimized 16-state Kalman Filter for Attitude and GPS-Aided Position-Velocity-Time (PVT) measurement. A free tool-chain based on VS Code supports PC, MAC, and Ubuntu.



OpenIMU300RI

Rugged Open-Source IMU with CAN Output

The ACEINNA OpenIMU300RI is designed for use in 12 V and 24 V vehicle platforms. The plastic over-molded sealed packaging meets the challenging performance, reliability and cost requirements of the automotive, construction and agriculture vehicle markets.

Applications

- Autonomous Vehicles
- Self-Driving Taxis / Delivery Vehicles
- Construction Vehicles
 - Boom, Bucket and Cab Attitude
- Agriculture Vehicles and Implements
- Forklifts
- Robotics Control / Feedback
- Antenna / Camera Gimbaling and Stabilization



Features

- Precision 3-axis MEMS Accelerometer
- Low-Drift 3-axis MEMS angular rate sensor
- High Performance 3-axis AMR Magnetometer
- CAN 2.0 and RS232 Interfaces
- 168 MHz ARM M4 processor
- Open Source Tool Chain
- Open Source Algorithms (VG / AHRS / INS)
- Built in 16-State Open Source Extended State Kalman Filter
- Open Community & Support
- Wide Temp Range, -40C to +85C
- Wide Supply Voltage Range, 5 V – 32 V
- IP67 Ampseal Connector
- High Reliability, MTBF > 50k hours

This product has been developed exclusively for commercial applications. It has not been tested for, and makes no representation or warranty as to conformance with, any military specifications or its suitability for any military application or end-use. Additionally, any use of this product for nuclear, chemical or biological weapons, or weapons research, or for any use in missiles, rockets, and/or UAV's of 300km or greater range, or any other activity prohibited by the Export Administration Regulations, is expressly prohibited without the written consent and without obtaining appropriate US export license(s) when required by US law. Diversion contrary to U.S. law is prohibited. Specifications are subject to change without notice.



OpenIMU300RI

Rugged Open-Source IMU with CAN Output

Performance Specification

Ta = 25°C, VDC = 12 V, unless otherwise stated

Angular Rate	MIN	TYP ²	MAX
Range (°/s)	-400		+400
Bias Instability (°/hr) ¹		6	
Bias Stability over Temp (°/s)		0.3	
Scale Factor Accuracy (%)		0.03	
Cross-Axis Error (%FSR)		0.02	
Angle Random Walk (°/√hr) ¹		0.3	
Configurable Bandwidth (Hz)	5		50
Acceleration	MIN	TYP ²	MAX
Range (g)	-8		+8
Bias Instability (μg) ¹		10	
Bias Stability over Temp (mg)		3	
Scale Factor Accuracy (%FSR)		0.03	
Non-Linearity (%FSR)		0.03	
VRW (m/s/√hr) ¹		0.06	
Configurable Bandwidth (Hz)	2		50
Magnetic Field	MIN	TYP ²	MAX
Range (mGauss)	-8000		+8000
Resolution (mGauss)		0.3	
Noise (mGauss/√Hz)		0.25	
Bandwidth (Hz)		5	

Note 1: Allan variance curve, constant temperature

Note 2: Typical values are 1-sigma values unless otherwise noted

Electrical Specifications

Characteristic	Specification
Input voltage	4.9 – 32 V
Over voltage	36 V
Reverse voltage	-36 V
Current	< 100 mA
Power	< 400 mW
Reset response	Automatic after voltage dropout
Start-up time	<2 seconds
Max Output Data Rate	100 Hz
CAN Baud rate	250k – 1M
RS232 Baud Rate	38400 – 230400

Physical Specifications

Characteristic	Specification
Dimensions	65 x 66 x 27 mm
Weight	< 75 g
Interface Connector	Ampseal 16 – 6 Position IP67
Mating Connector	TE Connectivity 776531-1

Environmental Specifications

Characteristic	Specification
Operating Temperature	-40 – 85 °C
Storage Temperature	-40 – 85 °C
Ingress Protection	IP67, IP69K

Qualification Summary (Not inclusive of all tests)

Electrical Loads	DUTs	Op Mode ³	Function Class ³	Summary
Over Voltage (V)	3	3.2	A	SAE J1455 4.13.1: 36 V, 1 hour
Reverse Voltage (V)	3	1.1	C	SAE J1455 4.13.1: -36 V, 5 minutes
Short Circuit	3	3.2	C	SAE J1455, 4.13.1: 32V
Starting Profile	3	3.2	A	10 cycles, 12 V System, Class IV
Load dump	3	3.2	A	5 pulses, 64V, 60 s pulse rate; 95 pulses 56V 120 s pulse rate
Reset Behavior at Voltage Drop	1	3.2	B	ISO 16750-2: 4.6.2
Mechanical Loads				
Vibration Swept Sine	3	3.2	A	5 – 500 Hz; <10 Hz Displacement = ± 12 mm; >10 Hz = 5 g Pk
Vibration Random	3	3.2	C	10 – 2000 Hz; 13.9 g RMS
Mechanical Bump	4	3.2	C	100 bumps x 3 axis/DUT (600 Total/DUT) 400m/s ² , ½ sine, 6 ms pulse
Mechanical Shock	4	3.2	C	3 Shocks x 3 axis x 2 directions (18 total) 500m/s ² , ½ sine, 11 ms pulse
Mechanical Drop	2	1.1	C	1 m to steel plate, 1 drop x 3 axis x 2 directions (6 total)
Climatic Loads				
Hot Soak	10	3.2	A	96 Hours 85 °C
Cold Soak	10	3.2	A	96 Hours -40 °C
Temperature Cycle	10	3.2	A	2 cycles, -40 – 85 °C
Temperature Shock	10	1.1	C	10 Cycles; -40 - 85 °C, <30s Transition, 3 hour dwell
Chemical Loads				
Salt Spray	2	1.1	C	EN 60068-2-52 Kb. Salt mist Cyclic (NaCl Solution) 35 °C
General	2	3.2	A	Engine oil, Diesel, Hydraulic Oil, Ethylene Glycol, Urea Nitrogen, Liquid Lime, NPK Fertilizer, Ammonia, Calcium Chloride

Note 3: ISO 16750-1 Operation Mode and Function Class definition

EMC Specifications

Characteristic	Standard	Test Level / Frequency	
ESD direct contact discharge	ISO 13766	8 kV - Function Class A, Reference Limits IV	
ESD air discharge	ISO 13766	15 kV - Function Class A, Reference Limits IV	
Radiated Immunity	ISO 11452-2	100 V/m, 200 – 2000 MHz	
Bulk current injection	ISO 11452-2	100 mA, 20 – 400 MHz	
EMC Transient Emissions	ISO 13766	30 – 75 MHz	51 Bb uV/m
		75-400 MHz	51+15.13 log (freq in MHz/75)
		400 – 1000 MHz	62 dB uV/m
EMC Conducted Transmission	ISO 13766; 7637	24V Parameters, Pulse 1, 2a, 2b, 3a, 3b,, 4, 5b	

Development Kit

- OpenIMU300RI EVK
- Special Housing with JTAG connection for development / debugging
- ST-Link debugger for in-system development of application code
- Fixture and Interface JTAG board
- Development Cable with Ampseal 16-6 Position to Dual DB9
 - CAN 2.0 Connection DB9
 - RS232 Connection DB9
 - Flying Lead for power connection

Open Navigation Platform

Embedded navigation applications quickly developed on PC, MAC, and Ubuntu and deployed to run on OpenIMU hardware.

- Code / Compile / Debug
- Simulate / Analyze

Aceinna Navigation Studio developer tools and GUI are found on our developer site: developers.aceinna.com

Full manual, API and Algorithm documentation are found at: openimu.readthedocs.io

IDE and Compilation tools, download VS Code and Add Aceinna Extension: code.visualstudio.com

Ready to Use Open Source Algorithms

- Calibrated IMU, 3D Acceleration, 3D Rate, 3D Mag
- VG / AHRS, Dynamic Roll, Pitch and Heading
- INS, Position, Velocity, Attitude and Heading

Development System Requirements

- PC or MAC
- USB Port (2.0)
- Internet Connection

Dimensioned Drawing

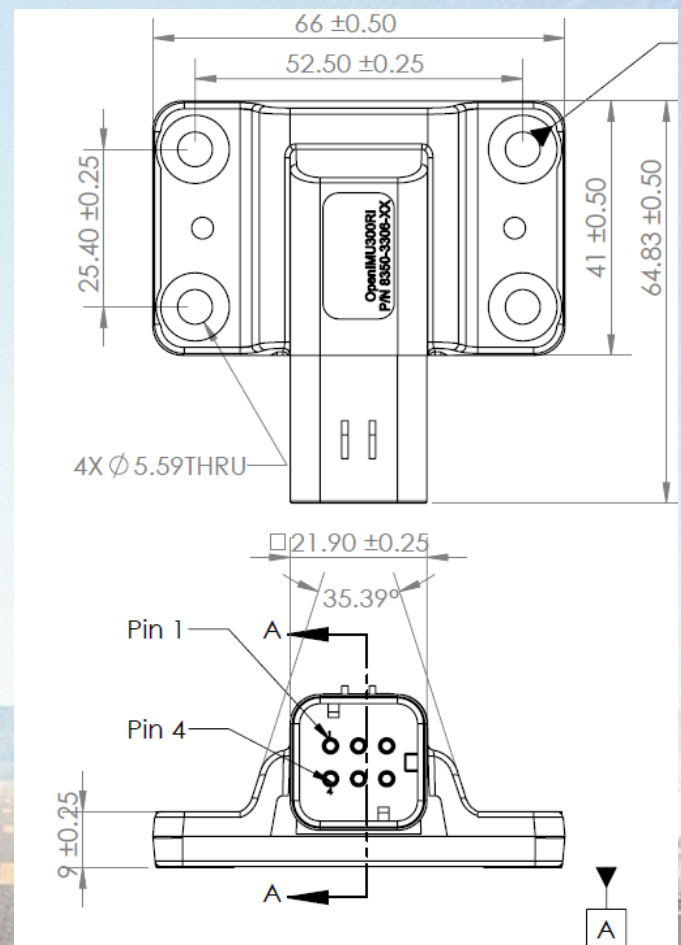

Ordering Information

Part Ordering Information	
Rugged High-Performance OpenIMU Platform	
OpenIMU300RI	Industrial Grade: 9 DOF IMU, FSR = 400dps / ±8g
OpenIMU300RI EVK	Developer Kit with OpenIMU300RI with JTAG, STLink/v2 and developer cable

Компания «Life Electronics» занимается поставками электронных компонентов импортного и отечественного производства от производителей и со складов крупных дистрибьюторов Европы, Америки и Азии.

С конца 2013 года компания активно расширяет линейку поставок компонентов по направлению коаксиальный кабель, кварцевые генераторы и конденсаторы (керамические, пленочные, электролитические), за счёт заключения дистрибьюторских договоров

Мы предлагаем:

- Конкурентоспособные цены и скидки постоянным клиентам.
- Специальные условия для постоянных клиентов.
- Подбор аналогов.
- Поставку компонентов в любых объемах, удовлетворяющих вашим потребностям.
- Приемлемые сроки поставки, возможна ускоренная поставка.
- Доставку товара в любую точку России и стран СНГ.
- Комплексную поставку.
- Работу по проектам и поставку образцов.
- Формирование склада под заказчика.
- Сертификаты соответствия на поставляемую продукцию (по желанию клиента).
- Тестирование поставляемой продукции.
- Поставку компонентов, требующих военную и космическую приемку.
- Входной контроль качества.
- Наличие сертификата ISO.

В составе нашей компании организован Конструкторский отдел, призванный помогать разработчикам, и инженерам.

Конструкторский отдел помогает осуществить:

- Регистрацию проекта у производителя компонентов.
- Техническую поддержку проекта.
- Защиту от снятия компонента с производства.
- Оценку стоимости проекта по компонентам.
- Изготовление тестовой платы монтаж и пусконаладочные работы.



Тел: +7 (812) 336 43 04 (многоканальный)

Email: org@lifeelectronics.ru