

NJG1556KB2

■ABSOLUTE MAXIMUM RATINGS

($T_a=25^{\circ}\text{C}$, $Z_s=Z_l=50\Omega$)

PARAMETERS	SYMBOL	CONDITIONS	RATINGS	UNITS
Mixer Supply Voltage	V_{MIX}		5	V
Local Amplifier Supply Voltage	V_{LO}		5	V
Mixer RF Input Power	P_{RFIN}	$V_{\text{MIX}}=2.7\text{V}, V_{\text{LO}}=2.7\text{V}$	+10	dBm
Mixer LO Input Power	P_{LOIN}	$V_{\text{MIX}}=2.7\text{V}, V_{\text{LO}}=2.7\text{V}$	+10	dBm
Power Dissipation	P_{D}		450	mW
Operating Temperature	T_{opr}		-40~+85	$^{\circ}\text{C}$
Storage Temperature	T_{stg}		-55~+125	$^{\circ}\text{C}$

■ELECTRICAL CHARACTERISTICS 1 (DC CHARACTERISTICS)

($T_a=25^{\circ}\text{C}$)

PARAMETERS	SYMBOL	CONDITIONS	MIN	TYP	MAX	UNITS
Mixer Supply Voltage	V_{MIX}		2.5	2.7	4.5	V
Local Amplifier Supply Voltage	V_{LO}		2.5	2.7	4.5	V
Mixer Current	I_{MIX}	$P_{\text{RF}}=\text{OFF}, P_{\text{LO}}=\text{OFF}$	-	5.0	6.3	mA
Local Amplifier Current	I_{LO}	$P_{\text{RF}}=\text{OFF}, P_{\text{LO}}=\text{OFF}$	-	1.0	1.5	mA

■ELECTRICAL CHARACTERISTICS 2 (AC CHARACTERISTICS PDC 1.5GHz BAND)

GENERAL CONDITIONS: $T_a=25^{\circ}\text{C}$, $V_{\text{MIX}}=2.7\text{V}$, $V_{\text{LO}}=2.7\text{V}$, $f_{\text{RF}}=1489\text{MHz}$, $f_{\text{LO}}=1619\text{MHz}$

$P_{\text{RF}}=-30\text{dBm}$, $P_{\text{LO}}=-15\text{dBm}$, $Z_s=Z_l=50\Omega$, with test circuit 1

PARAMETERS	SYMBOL	CONDITIONS	MIN	TYP	MAX	UNITS
Operating Frequency	freq1		1470	1489	1510	MHz
Conversion Gain	Gc1		8.0	10.0	-	dB
Input 3rd Order Intercept point	IIP3_1	$f_{\text{RF}}=1489.0\text{MHz}+1489.1\text{MHz}$	-4.0	-1.0	-	dBm
Noise Figure	NF1		-	7.0	8.5	dB
LO to RF Isolation	ISL1	IF OUT Port: 50Ω term.	-	2.0	-	dB

■ELECTRICAL CHARACTERISTICS 3 (AC CHARACTERISTICS PCS 1.9GHz BAND)

GENERAL CONDITIONS: $T_a=25^{\circ}\text{C}$, $V_{\text{MIX}}=2.7\text{V}$, $V_{\text{LO}}=2.7\text{V}$, $f_{\text{RF}}=1960\text{MHz}$, $f_{\text{LO}}=2090\text{MHz}$

$P_{\text{RF}}=-30\text{dBm}$, $P_{\text{LO}}=-10\text{dBm}$, $Z_s=Z_l=50\Omega$, with test circuit 2

PARAMETERS	SYMBOL	CONDITIONS	MIN	TYP	MAX	UNITS
Operating Frequency	freq2		1920	1960	2000	MHz
Conversion Gain	Gc2		10.0	12.5	-	dB
Input 3rd Order Intercept point	IIP3_2	$f_{\text{RF}}=1900.0\text{MHz}+1900.1\text{MHz}$	-3.0	-0.5	-	dBm
Noise Figure	NF2		-	6.5	8.0	dB
LO to RF Isolation	ISL2	IF OUT Port: 50Ω term.	-	7.0	-	dB

■ TERMINAL INFORMATION

PIN No.	SYMBOL	DESCRIPTIONS
1	LOIN	Local power input terminal of local amplifier. External matching circuit is required.
2	GND	Ground terminal (0V).
3	RFIN	RF input terminal of mixer. External matching circuit is required.
4	IFOUT	IF signal output terminal for mixer external matching circuit is required. Please connect mixer power supply through choke inductor (L7) as shown in test circuit.
5	BPC	Optional bypass capacitor terminal for mixer. Please connect optimum capacitor if need for tuning Gc or IP3.
6	VLO	Local amplifier supply terminal. Please place R1 & L5 close to this terminal as shown in test circuit.

NOTE:

- 1) Ground terminal (2pin) should be connected with ground plane by multiple via holes for good grounding.

NJG1556KB2

■ TYPICAL CHARACTERISTICS (PDC 1.5GHz BAND)

Conversion Gain , Noise Figure vs. RF Frequency

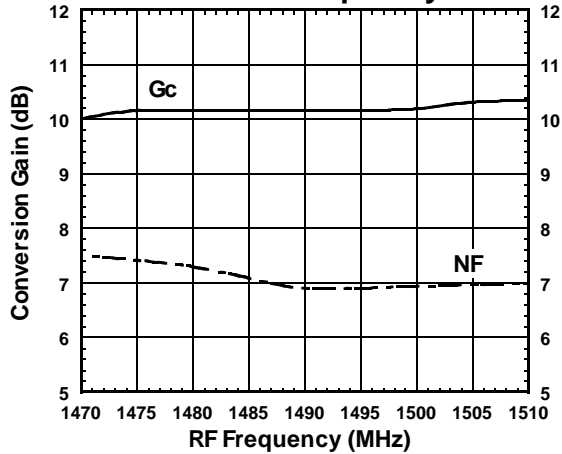

Condition
 $f_{IF}=130\text{MHz}$
 $f_{RF}=1470\sim 1510\text{MHz}$, $P_{RF}=-30\text{dBm}$
 $f_{LO}=1600\sim 1640\text{MHz}$, $P_{LO}=-15\text{dBm}$
 $V_{MIX}=V_{LO}=2.7\text{V}$

Conversion Gain , Noise Figure vs. LO Power

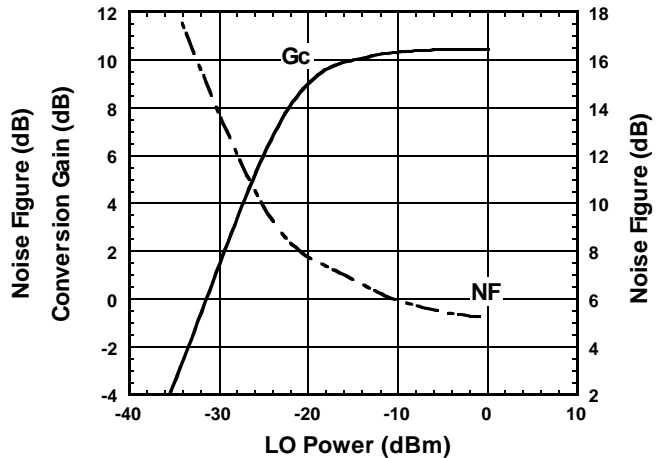

Condition
 $f_{IF}=130\text{MHz}$
 $f_{RF}=1489\text{MHz}$, $P_{RF}=-30\text{dBm}$
 $f_{LO}=1619\text{MHz}$
 $V_{MIX}=V_{LO}=2.7\text{V}$

Output IP3 , Input IP3 vs. RF Frequency

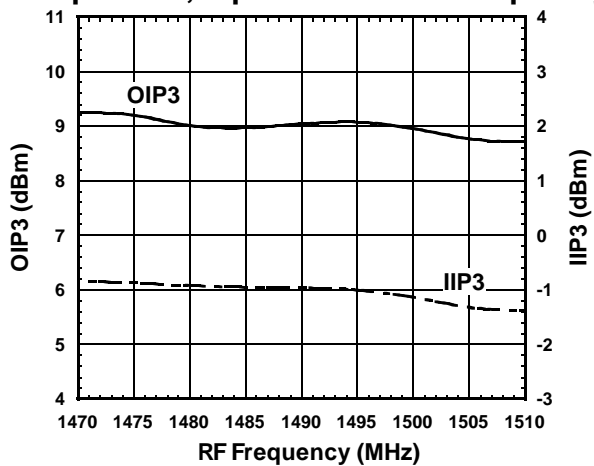

Condition
 $f_{IF}=130\text{MHz}$
 $f_{RF1}=1470\sim 1510\text{MHz}$, $P_{RF}=-30\text{dBm}$
 $f_{RF2}=f_{RF1}+100\text{kHz}$
 $f_{LO}=1600\sim 1640\text{MHz}$, $P_{LO}=-15\text{dBm}$
 $V_{MIX}=V_{LO}=2.7\text{V}$

Output IP3 , Input IP3 vs. LO Power

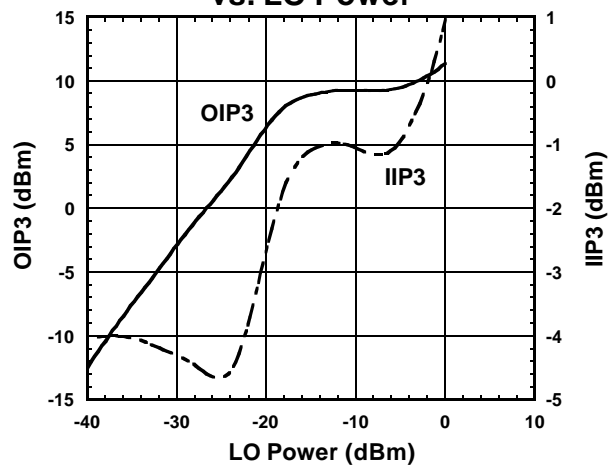

Condition
 $f_{IF}=130\text{MHz}$
 $f_{RF}=1489.0+1489.1\text{MHz}$
 $P_{RF}=-30\text{dBm}$
 $f_{LO}=1619\text{MHz}$
 $V_{MIX}=V_{LO}=2.7\text{V}$
 $OIP3 = \frac{3XIF-IM3}{2}$
 $IIP3 = OIP3 - Gc$

■ TYPICAL CHARACTERISTICS (Continued)

**Conversion Gain , Noise Figure
vs. V_{MIX} , V_{LO}**

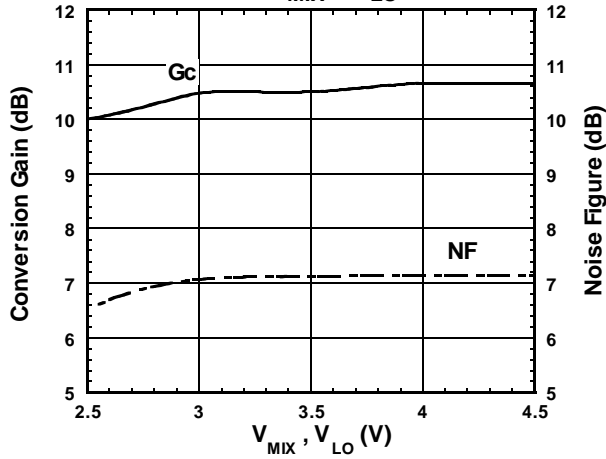

Condition
 $f_{IF}=130\text{MHz}$
 $f_{RF}=1489\text{MHz}$, $P_{RF}=-30\text{dBm}$
 $f_{LO}=1619\text{MHz}$, $P_{LO}=-15\text{dBm}$

**Output IP3 , Input IP3
vs. V_{MIX} , V_{LO}**

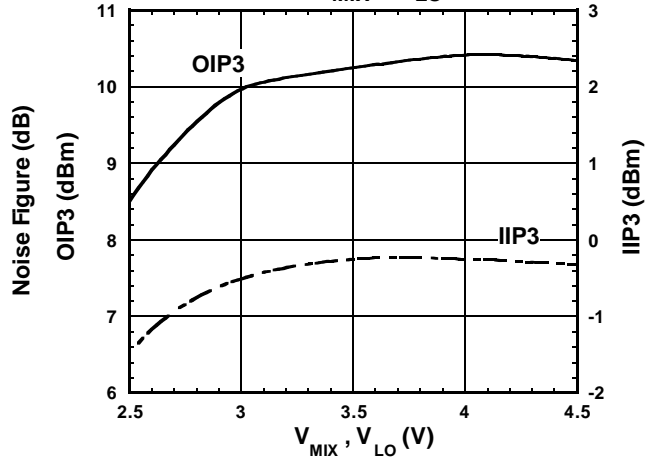

Condition
 $f_{IF}=130\text{MHz}$
 $f_{RF}=1489.0+1489.1\text{MHz}$, $P_{RF}=-30\text{dBm}$
 $f_{LO}=1619\text{MHz}$, $P_{LO}=-15\text{dBm}$
 $OIP3 = \frac{3XIF-IM3}{2}$
 $IIP3 = OIP3 - Gc$

IF Output Power vs. RF Power

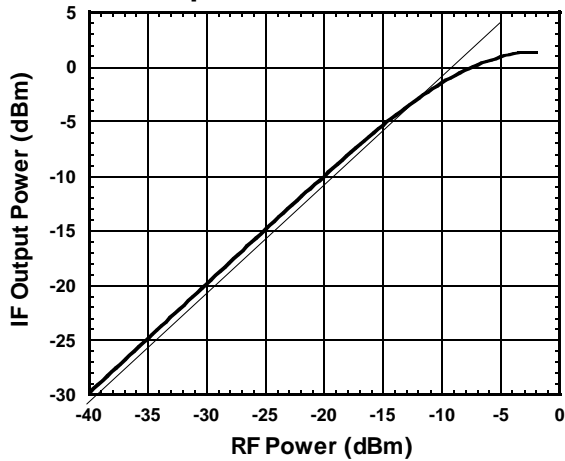

Condition
 $f_{IF}=130\text{MHz}$
 $f_{RF}=1489\text{MHz}$
 $f_{LO}=1619\text{MHz}$, $P_{LO}=-15\text{dBm}$
 $V_{MIX}=V_{LO}=2.7\text{V}$

IF , IM3 vs. RF Power

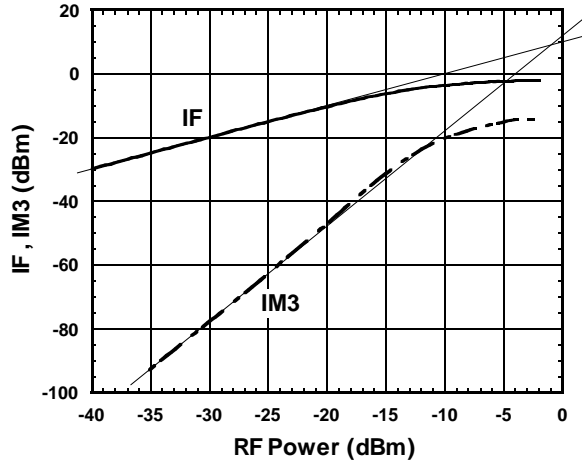

Condition
 $f_{IF}=130\text{MHz}$
 $f_{RF}=1489.0+1489.1\text{MHz}$
 $f_{LO}=1619\text{MHz}$, $P_{LO}=-15\text{dBm}$
 $V_{MIX}=V_{LO}=2.7\text{V}$

NJG1556KB2

■ TYPICAL CHARACTERISTICS (Continued)

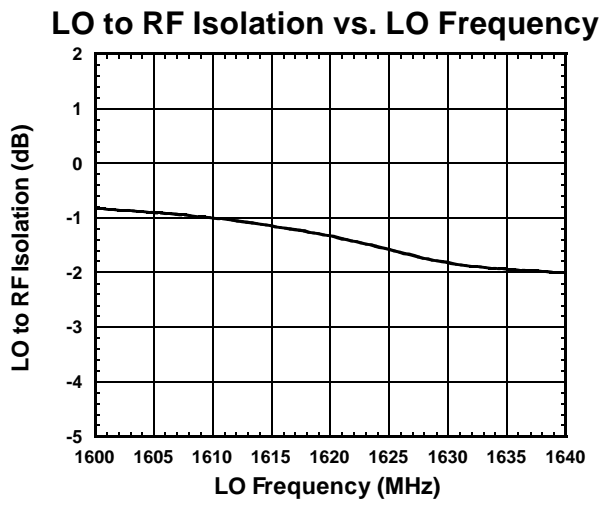

Condition
 $f_{LO}=1600\sim 1640\text{MHz}$
 $P_{LO}=-15\text{dBm}$
 $V_{MIX}=V_{LO}=2.7\text{V}$
IF OUT Port: 50Ω term.

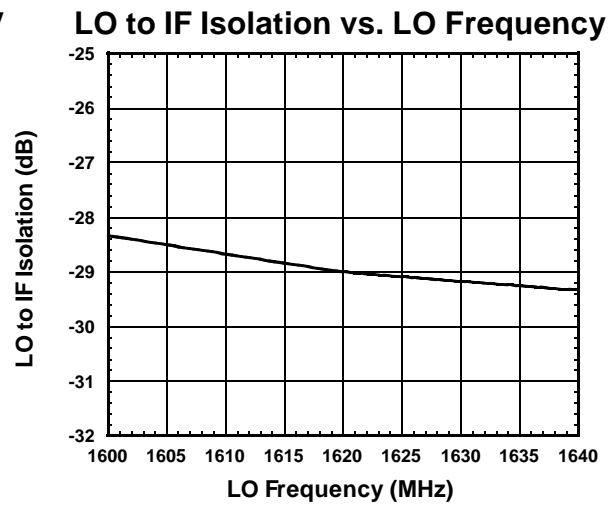

Condition
 $f_{LO}=1600\sim 1640\text{MHz}$
 $P_{LO}=-15\text{dBm}$
 $V_{MIX}=V_{LO}=2.7\text{V}$
RF IN Port: 50Ω term.

■ TYPICAL CHARACTERISTICS (Continued)

Conversion Gain , Noise Figure vs. Temperature

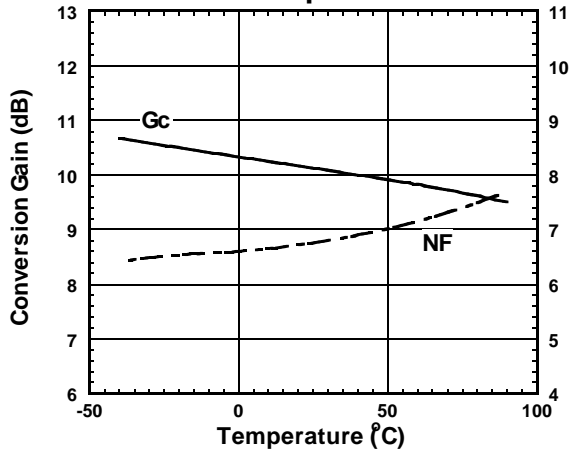

Condition
 $f_{IF}=130\text{MHz}$
 $f_{RF}=1489\text{MHz}$, $P_{RF}=-30\text{dBm}$
 $f_{LO}=1619\text{MHz}$, $P_{LO}=-15\text{dBm}$
 $V_{MIX}=V_{LO}=2.7\text{V}$

Output IP3 , Input IP3 vs. Temperature

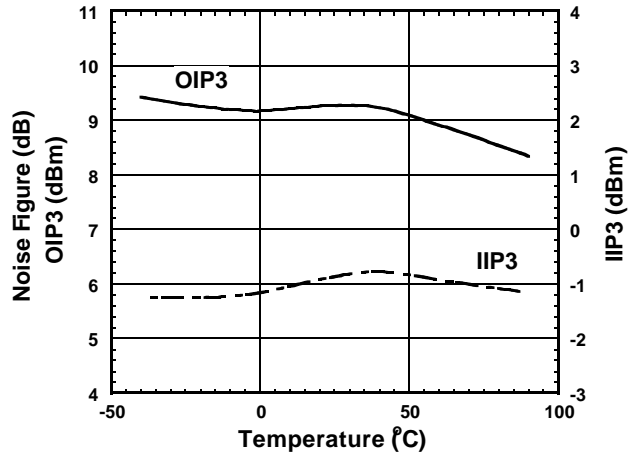

Condition
 $f_{IF}=130\text{MHz}$
 $f_{RF}=1489.0+1489.1\text{MHz}$ $OIP3 = \frac{3XIF-IM3}{2}$
 $P_{RF}=-30\text{dBm}$
 $f_{LO}=1619\text{MHz}$, $P_{LO}=-15\text{dBm}$ $IIP3=OIP3-Gc$
 $V_{MIX}=V_{LO}=2.7\text{V}$

LO to RF Isolation vs. Temperature

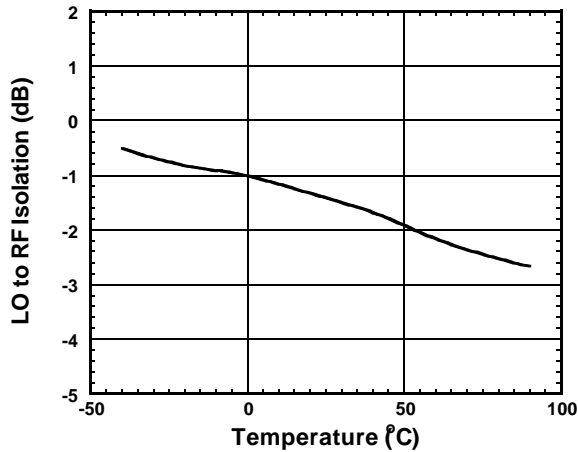

Condition
 $f_{LO}=1619\text{MHz}$
 $P_{LO}=-15\text{dBm}$
 $V_{MIX}=V_{LO}=2.7\text{V}$
 IF OUT Port: 50Ω term.

LO to IF Isolation vs. Temperature

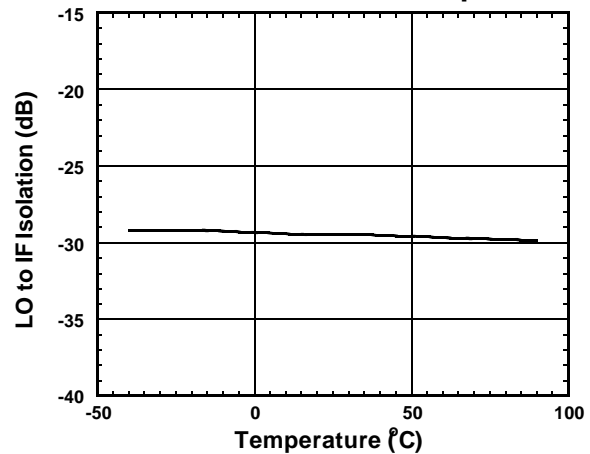

Condition
 $f_{LO}=1619\text{MHz}$
 $P_{LO}=-15\text{dBm}$
 $V_{MIX}=V_{LO}=2.7\text{V}$
 RF IN Port: 50Ω term.

NJG1556KB2

TYPICAL CHARACTERISTICS (Continued)

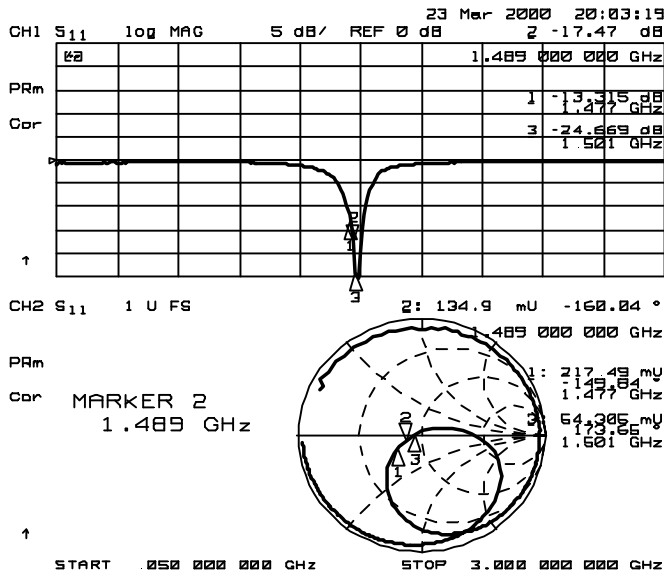

RF IN Port Impedance
(LOCAL IN Port, IF OUT Port: 50Ω term.)

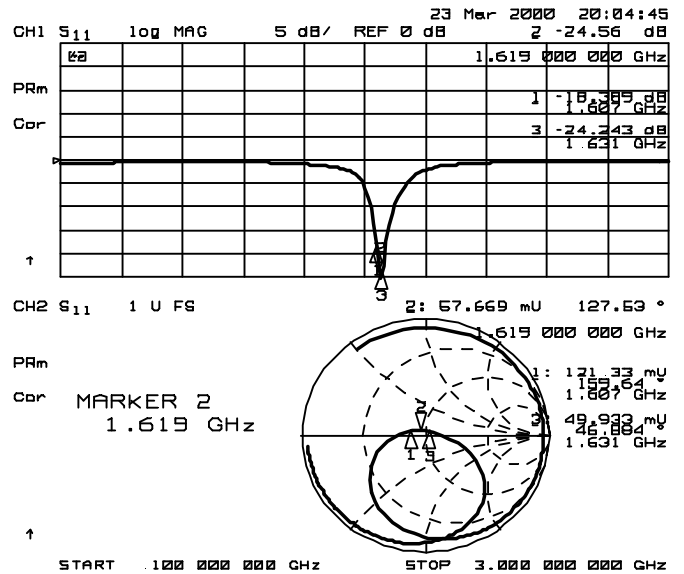

LOCAL IN Port Impedance
(RF IN Port, IF OUT Port: 50Ω term.)

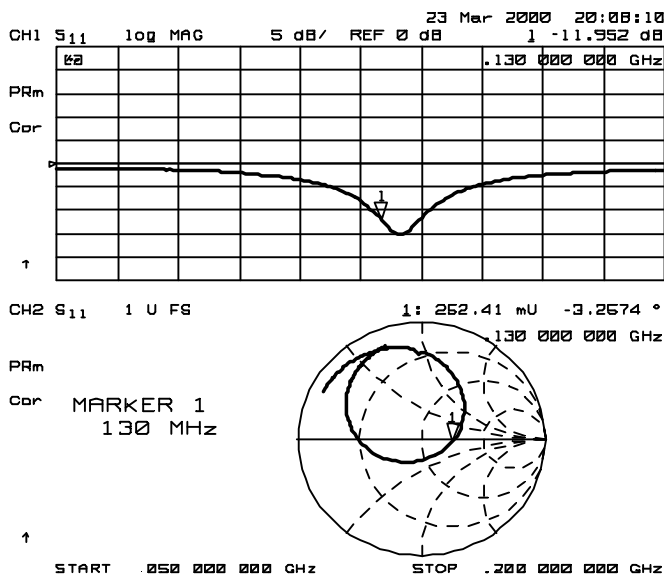

IF OUT Port Impedance
(RF IN Port, LOCAL IN Port: 50Ω term.)

■ TYPICAL CHARACTERISTICS (PCS 1.9GHz BAND)

Conversion Gain , Noise Figure vs. RF Frequency

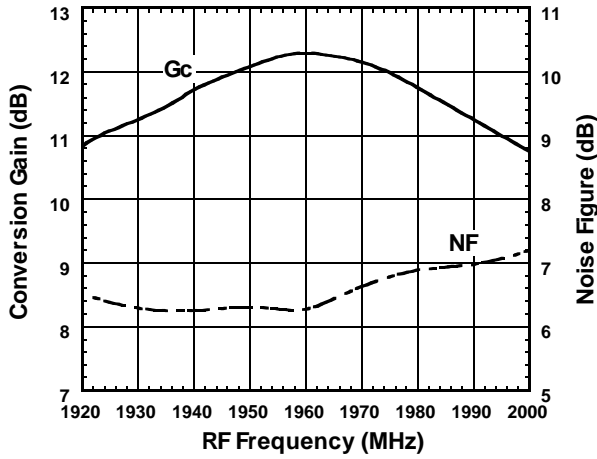

Condition
 $f_{IF}=130\text{MHz}$
 $f_{RF}=1920\sim 2000\text{MHz}, P_{RF}=-30\text{dBm}$
 $f_{LO}=2050\sim 2130\text{MHz}, P_{LO}=-10\text{dBm}$
 $V_{MIX}=V_{LO}=2.7\text{V}$

Conversion Gain , Noise Figure vs. LO Power

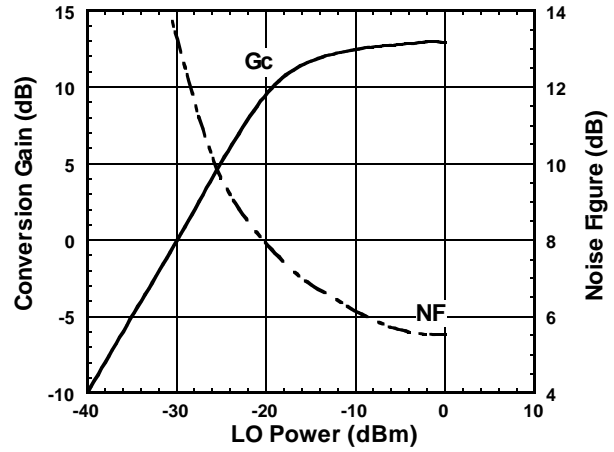

Condition
 $f_{IF}=130\text{MHz}$
 $f_{RF}=1960\text{MHz}, P_{RF}=-30\text{dBm}$
 $f_{LO}=2090\text{MHz}$
 $V_{MIX}=V_{LO}=2.7\text{V}$

Output IP3 , Input IP3 vs. RF Frequency

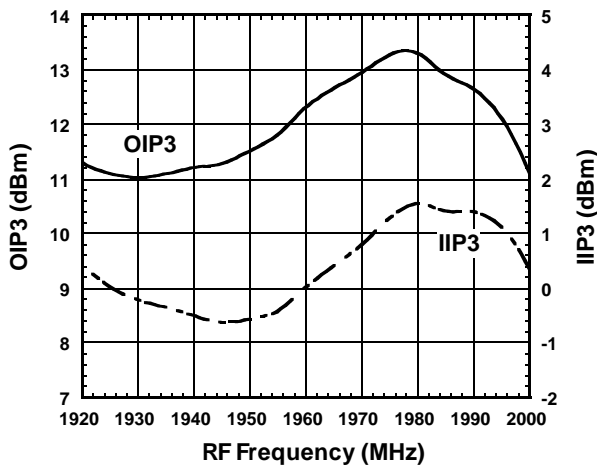

Condition
 $f_{IF}=130\text{MHz}$
 $f_{RF1}=1920\sim 2000\text{MHz}, P_{RF}=-30\text{dBm}$
 $f_{RF2}=f_{RF1}+100\text{kHz}$
 $f_{LO}=2050\sim 2130\text{MHz}, P_{LO}=-10\text{dBm}$
 $V_{MIX}=V_{LO}=2.7\text{V}$

Output IP3 , Input IP3 vs. LO Power

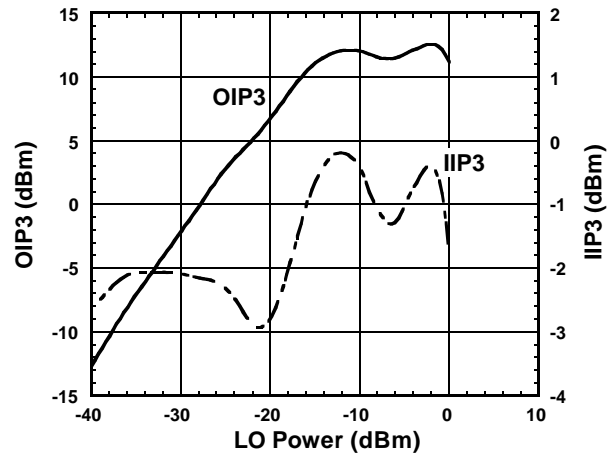

Condition
 $f_{IF}=130\text{MHz}$
 $f_{RF}=1960.0+1960.1\text{MHz}$
 $P_{RF}=-30\text{dBm}$
 $f_{LO}=2090\text{MHz}$
 $V_{MIX}=V_{LO}=2.7\text{V}$

$$OIP3 = \frac{3XIF - IM3}{2}$$

$$IIP3 = OIP3 - Gc$$

NJG1556KB2

■ TYPICAL CHARACTERISTICS (Continued)

Conversion Gain, Noise Figure
vs. V_{MIX} , V_{LO}

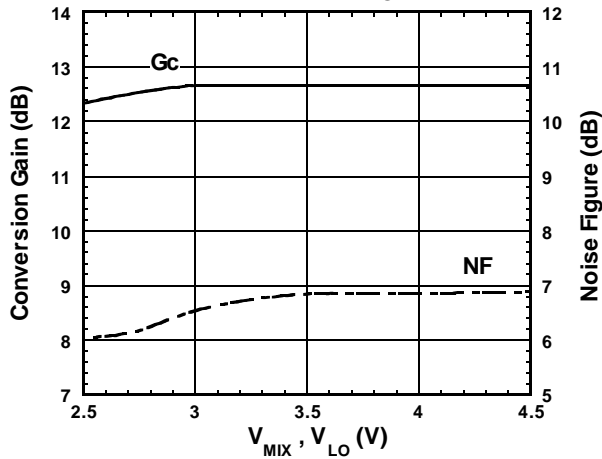

Condition
 $f_{IF}=130\text{MHz}$
 $f_{RF}=1960\text{MHz}$, $P_{RF}=-30\text{dBm}$
 $f_{LO}=2090\text{MHz}$, $P_{LO}=-10\text{dBm}$

Output IP3, Input IP3
vs. V_{MIX} , V_{LO}

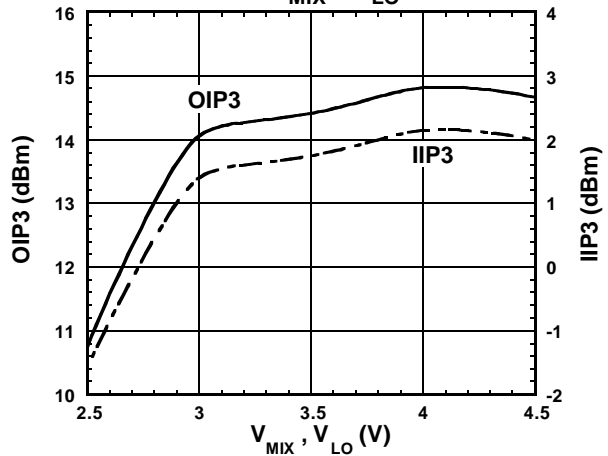

Condition
 $f_{IF}=130\text{MHz}$
 $f_{RF}=1960.0+1960.1\text{MHz}$, $P_{RF}=-30\text{dBm}$
 $f_{LO}=2090\text{MHz}$, $P_{LO}=-10\text{dBm}$
 $OIP3 = \frac{3 \times IIP3 - IM3}{2}$
 $IIP3 = OIP3 - Gc$

IF Output Power vs. RF Power

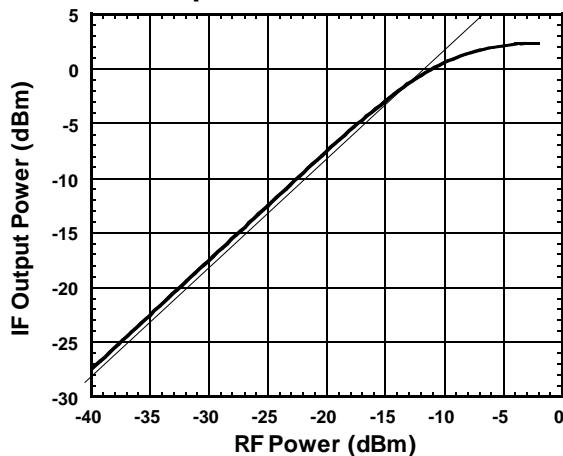

Condition
 $f_{IF}=130\text{MHz}$
 $f_{RF}=1960\text{MHz}$
 $f_{LO}=2090\text{MHz}$, $P_{LO}=-10\text{dBm}$
 $V_{MIX}=V_{LO}=2.7\text{V}$

IF, IM3 vs. RF Power

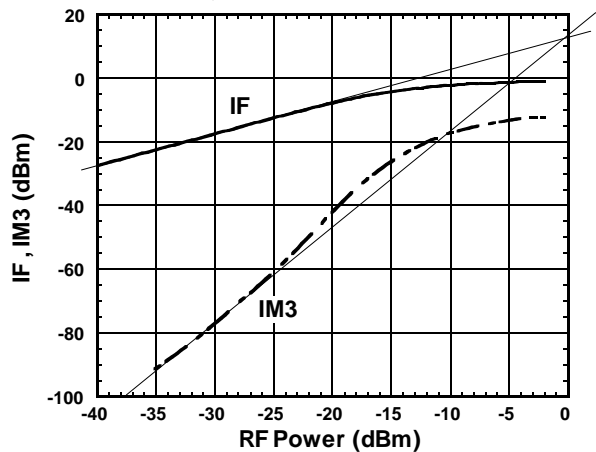

Condition
 $f_{IF}=130\text{MHz}$
 $f_{RF}=1960.0+1960.1\text{MHz}$
 $f_{LO}=2090\text{MHz}$, $P_{LO}=-10\text{dBm}$
 $V_{MIX}=V_{LO}=2.7\text{V}$

■ TYPICAL CHARACTERISTICS (Continued)

LO to RF Isolation vs. LO Frequency

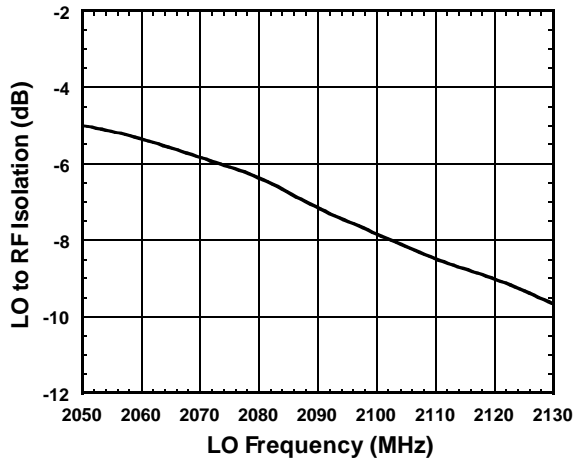

Condition
 $f_{LO}=2050\sim 2130\text{MHz}$
 $P_{LO}=-10\text{dBm}$
 $V_{MIX}=V_{LO}=2.7\text{V}$
 IF OUT Port: 50Ω term.

LO to IF Isolation vs. LO Frequency

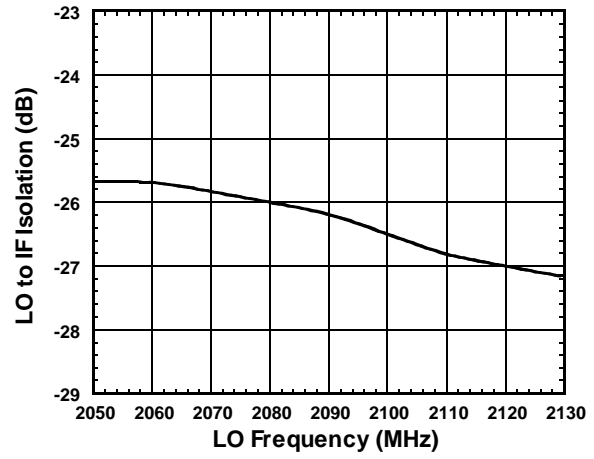

Condition
 $f_{LO}=2050\sim 2130\text{MHz}$
 $P_{LO}=-10\text{dBm}$
 $V_{MIX}=V_{LO}=2.7\text{V}$
 RF IN Port: 50Ω term.

NJG1556KB2

■ TYPICAL CHARACTERISTICS (Continued)

Conversion Gain , Noise Figure vs. Temperature

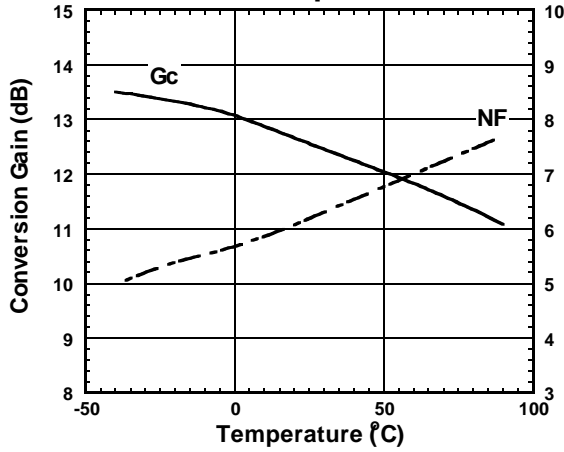

Condition
 $f_{IF}=130\text{MHz}$
 $f_{RF}=1960\text{MHz}$, $P_{RF}=-30\text{dBm}$
 $f_{LO}=2090\text{MHz}$, $P_{LO}=-10\text{dBm}$
 $V_{MIX}=V_{LO}=2.7\text{V}$

Output IP3 , Input IP3 vs. Temperature

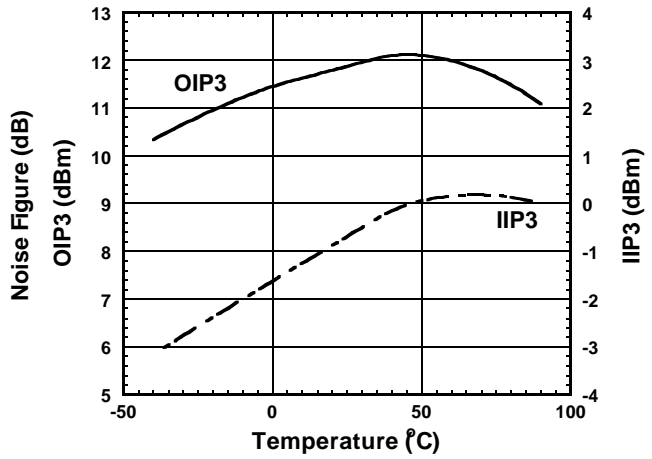

Condition
 $f_{IF}=130\text{MHz}$
 $f_{RF}=1960.0+1960.1\text{MHz}$ $OIP3=\frac{3XIF-IM3}{2}$
 $P_{RF}=-30\text{dBm}$
 $f_{LO}=2090\text{MHz}$, $P_{LO}=-10\text{dBm}$ $IIP3=OIP3-Gc$
 $V_{MIX}=V_{LO}=2.7\text{V}$

LO to RF Isolation vs. Temperature

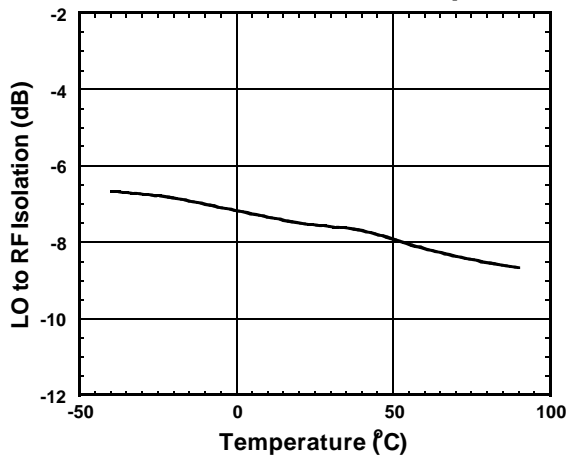

Condition
 $f_{LO}=2090\text{MHz}$
 $P_{LO}=-10\text{dBm}$
 $V_{MIX}=V_{LO}=2.7\text{V}$
 IF OUT Port: 50Ωterm.

LO to IF Isolation vs. Temperature

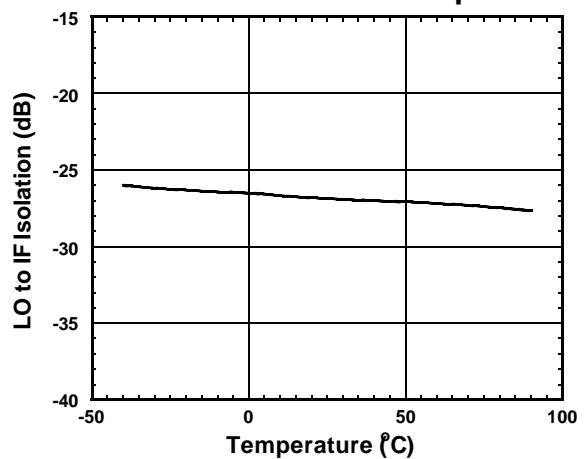

Condition
 $f_{LO}=2090\text{MHz}$
 $P_{LO}=-10\text{dBm}$
 $V_{MIX}=V_{LO}=2.7\text{V}$
 RF IN Port: 50Ωterm.

TYPICAL CHARACTERISTICS (Continued)

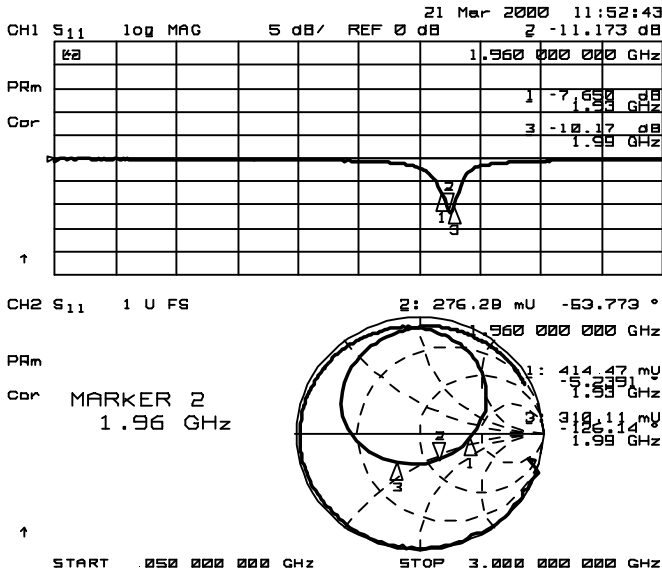

RF IN Port Impedance
(LOCAL IN Port, IF OUT Port : 50Ω term.)

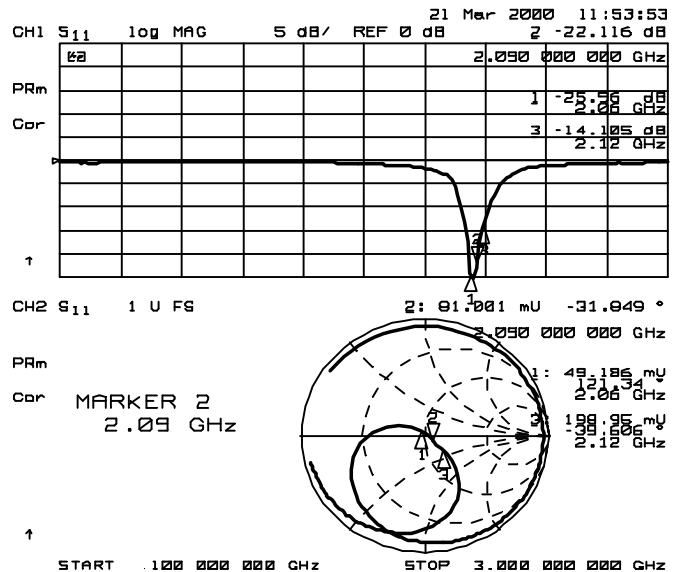

LOCAL IN Port Impedance
(RF IN Port, IF OUT Port : 50Ω term.)

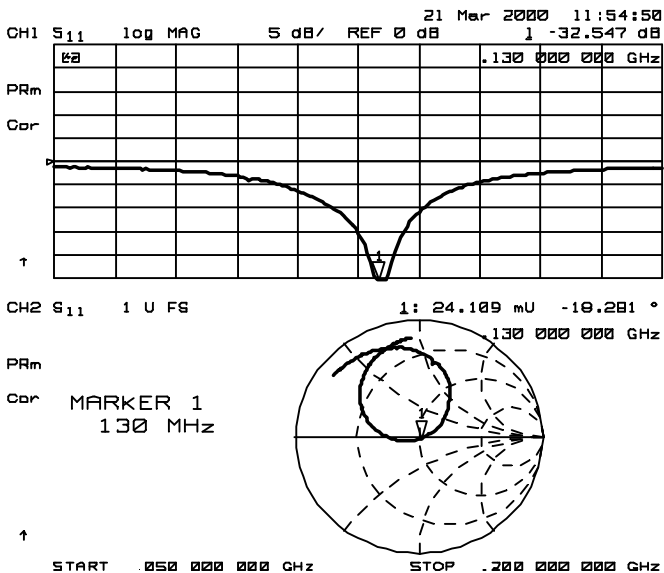

IF OUT Port Impedance
(RF IN Port, LOCAL IN Port : 50Ω term.)

NJG1556KB2

APPLICATION CIRCUIT 1 (PDC 1.5GHz BAND)

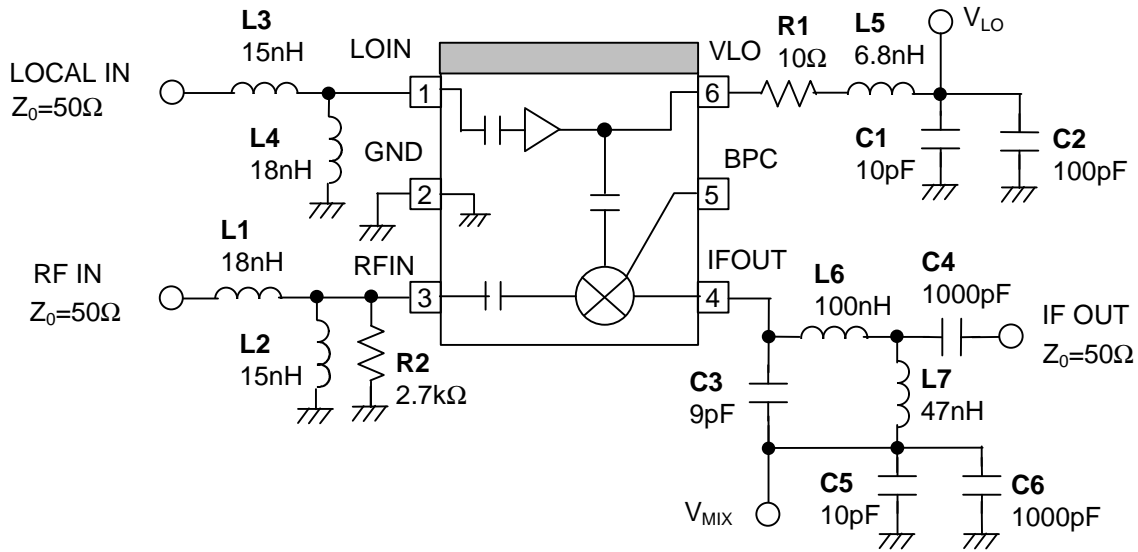

RECOMMENDED PCB DESIGN 1 (PDC 1.5GHz BAND)

(Top View)

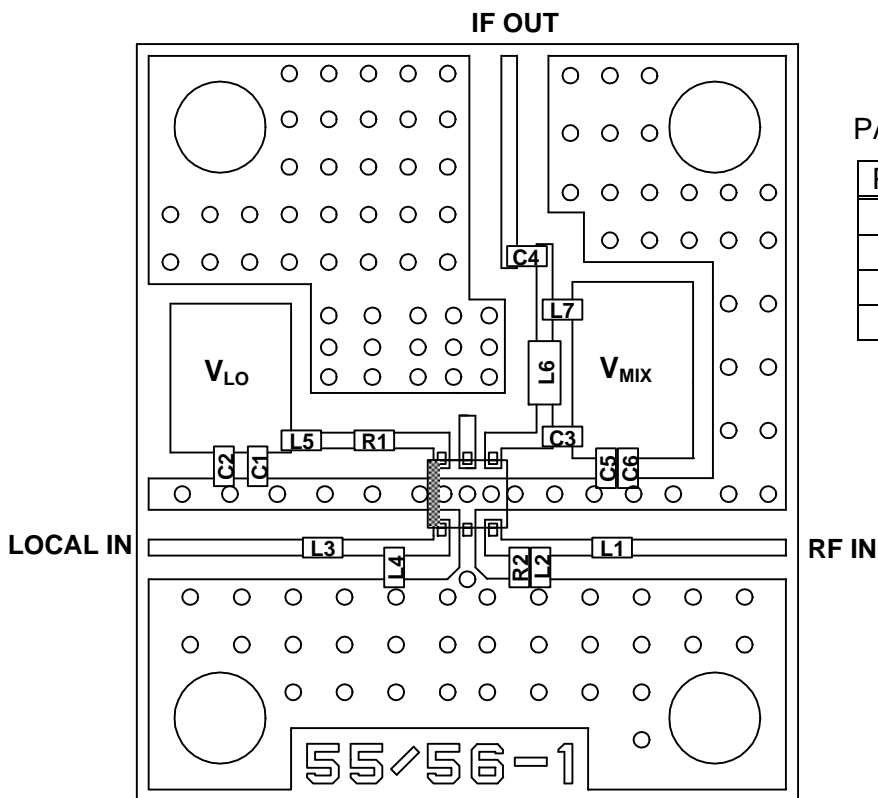

PARTS LIST

PARTS ID	COMMENT
L1~L5,L7	TAIYO-YUDEN(HK1005)
L6	TAIYO-YUDEN(HK1608)
C1~C6	MURATA(GRM36)
R1,R2	1005 Size

PCB (FR-4), t=0.2mm
 STRIP LINE WIDTH
 =0.4mm ($Z_0=50\Omega$)
 PCB SIZE
 =16.7X19.1mm

PRECAUTIONS

- [1] Please locate L5 and R1 close to VLO terminal (6).
- [2] Please locate C1 and C2 close to L5.
- [3] Please locate C5 and C6 close to C3.

APPLICATION CIRCUIT 2 (PCS 1.9GHz BAND)

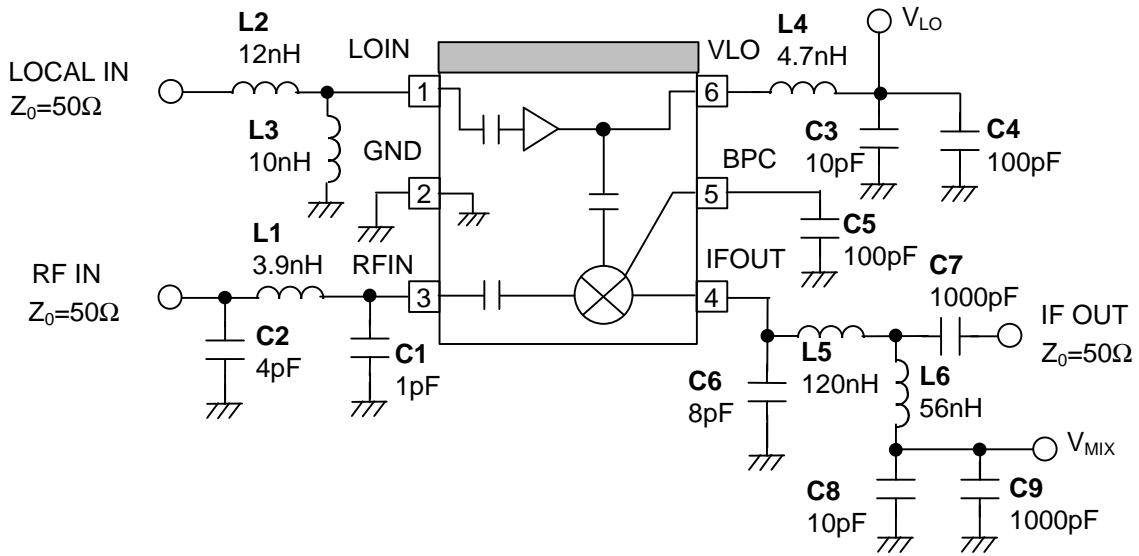

RECOMMENDED PCB DESIGN 2 (PCS 1.9GHz BAND)

(Top View)

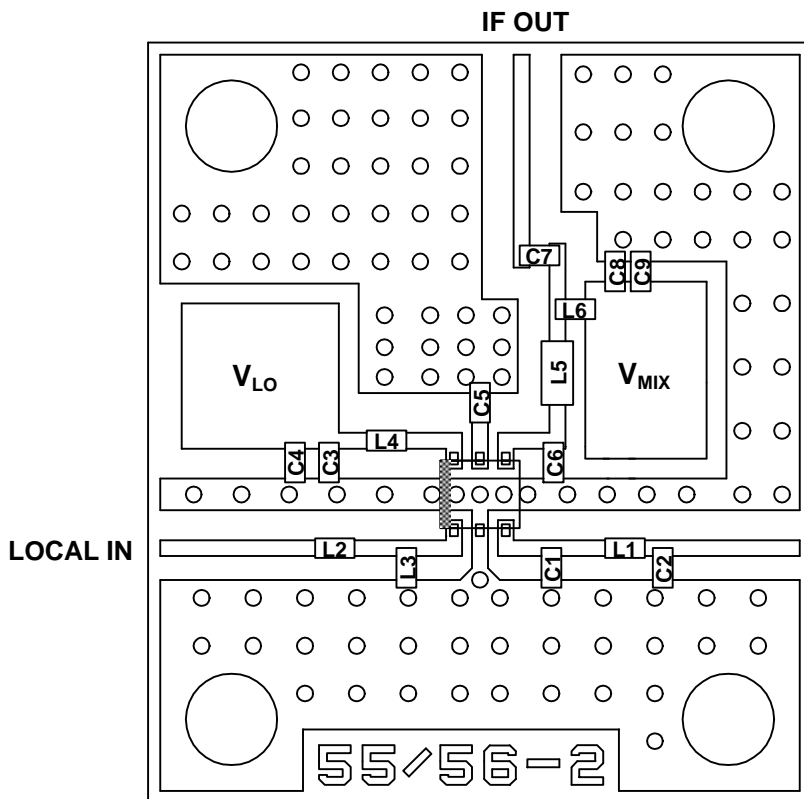

PARTS LIST

PARTS ID	COMMENT
L1~L4,L6	TAIYO-YUDEN(HK1005)
L5	TAIYO-YUDEN(HK1608)
C1~C9	MURATA(GRM36)

PCB (FR-4), t=0.2mm
 STRIP LINE WIDTH
 =0.4mm ($Z_0=50\Omega$)
 PCB SIZE
 =16.7X19.1mm

PRECAUTIONS

- [1] Please locate L4 close to VLO terminal (6).
- [2] Please locate C5 close to BPC terminal (5).
- [3] Please locate C3 and C4 close to L4.
- [4] Please locate C8 and C9 close to L6.

MEASURING BLOCK DIAGRAM

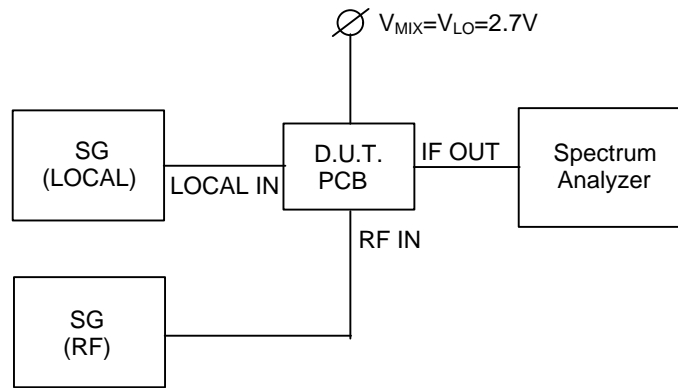

Conversion Gain Measuring Block Diagram

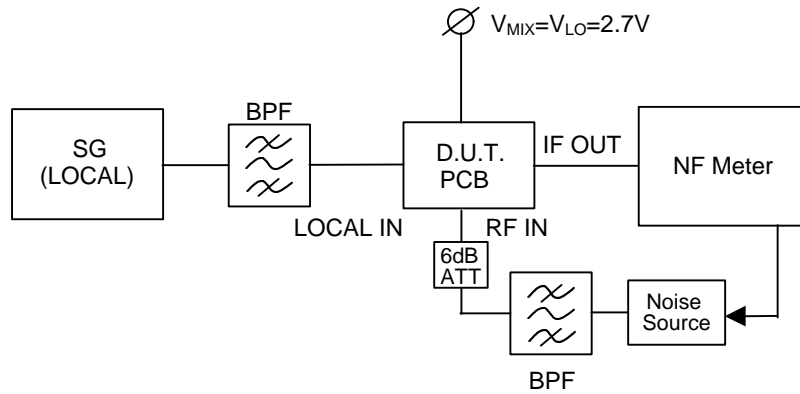

Noise Figure Measuring Block Diagram

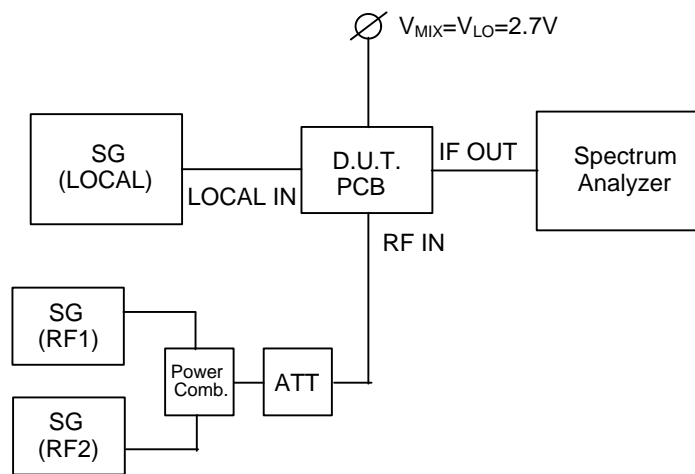

OIP3, IIP3 Measuring Block Diagram

PACKAGE OUTLINE (FLP6-B2)

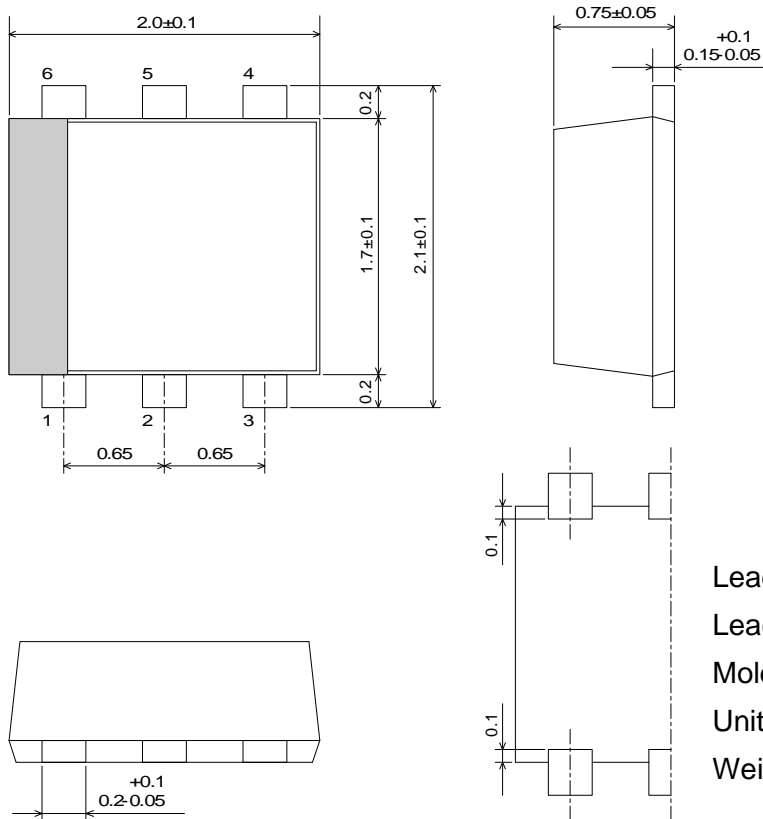

Lead material	: Copper
Lead surface finish	: Solder plating
Molding material	: Epoxy resin
Unit	: mm
Weight	: 6.5mg

Cautions on using this product

This product contains Gallium-Arsenide (GaAs) which is a harmful material.

- Do NOT eat or put into mouth.
- Do NOT dispose in fire or break up this product.
- Do NOT chemically make gas or powder with this product.
- To waste this product, please obey the relating law of your country.

[CAUTION]

The specifications on this databook are only given for information, without any guarantee as regards either mistakes or omissions. The application circuits in this databook are described only to show representative usages of the product and not intended for the guarantee or permission of any right including the industrial rights.

This product may be damaged with electric static discharge (ESD) or spike voltage. Please handle with care to avoid these damages.

Компания «Life Electronics» занимается поставками электронных компонентов импортного и отечественного производства от производителей и со складов крупных дистрибьюторов Европы, Америки и Азии.

С конца 2013 года компания активно расширяет линейку поставок компонентов по направлению коаксиальный кабель, кварцевые генераторы и конденсаторы (керамические, пленочные, электролитические), за счёт заключения дистрибьюторских договоров

Мы предлагаем:

- Конкурентоспособные цены и скидки постоянным клиентам.
- Специальные условия для постоянных клиентов.
- Подбор аналогов.
- Поставку компонентов в любых объемах, удовлетворяющих вашим потребностям.
- Приемлемые сроки поставки, возможна ускоренная поставка.
- Доставку товара в любую точку России и стран СНГ.
- Комплексную поставку.
- Работу по проектам и поставку образцов.
- Формирование склада под заказчика.
- Сертификаты соответствия на поставляемую продукцию (по желанию клиента).
- Тестирование поставляемой продукции.
- Поставку компонентов, требующих военную и космическую приемку.
- Входной контроль качества.
- Наличие сертификата ISO.

В составе нашей компании организован Конструкторский отдел, призванный помогать разработчикам, и инженерам.

Конструкторский отдел помогает осуществить:

- Регистрацию проекта у производителя компонентов.
- Техническую поддержку проекта.
- Защиту от снятия компонента с производства.
- Оценку стоимости проекта по компонентам.
- Изготовление тестовой платы монтаж и пусконаладочные работы.



Тел: +7 (812) 336 43 04 (многоканальный)
Email: org@lifeelectronics.ru