

### FEATURES

#### 8 channels of LNA, VGA, AAF, and ADC

#### Low noise preamplifier (LNA)

Input-referred noise = 1.1 nV/√Hz @ 5 MHz typical,  
gain = 18 dB

SPI-programmable gain = 14 dB/15.6 dB/18 dB

Single-ended input;  $V_{IN}$  maximum = 400 mV p-p/  
333 mV p-p/250 mV p-p

Dual-mode active input impedance matching

Bandwidth (BW) > 70 MHz

Full-scale (FS) output = 2 V p-p differential

#### Variable gain amplifier (VGA)

Gain range = -6 dB to +24 dB

Linear-in-dB gain control

#### Antialiasing filter (AAF)

3<sup>rd</sup>-order Butterworth cutoff

Programmable from 8 MHz to 18 MHz

#### Analog-to-digital converter (ADC)

12 bits at 10 MSPS to 50 MSPS

SNR = 70 dB

SFDR = 80 dB

Serial LVDS (ANSI-644, IEEE 1596.3 reduced range link)

Data and frame clock outputs

#### Includes crosspoint switch to support continuous wave (CW) Doppler

Low power, 150 mW per channel at 12 bits/40 MSPS (TGC)

90 mW per channel in CW Doppler

Single 1.8 V supply (3.3 V supply for CW Doppler output bias)

Flexible power-down modes

Overload recovery in < 10 ns

Fast recovery from low power standby mode, < 2 μs

100-lead TQFP

### APPLICATIONS

Medical imaging/ultrasound

Automotive radar

### GENERAL DESCRIPTION

The AD9271 is designed for low cost, low power, small size, and ease of use. It contains eight channels of a variable gain amplifier (VGA) with low noise preamplifier (LNA); an antialiasing filter (AAF); and a 12-bit, 10 MSPS to 50 MSPS analog-to-digital converter (ADC).

Each channel features a variable gain range of 30 dB, a fully differential signal path, an active input preamplifier termination, a maximum gain of up to 40 dB, and an ADC with a conversion rate of up to 50 MSPS. The channel is optimized for dynamic performance and low power in applications where a small package size is critical.

### FUNCTIONAL BLOCK DIAGRAM

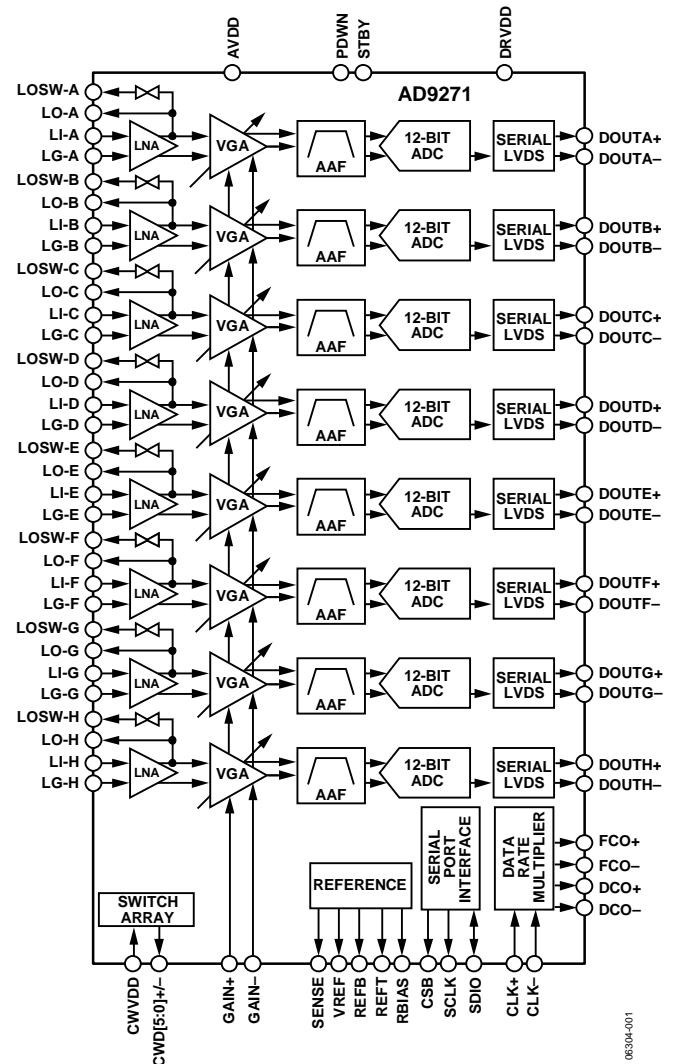

Figure 1.

The LNA has a single-ended-to-differential gain that is selectable through the SPI. The LNA input noise is typically 1.2 nV/√Hz, and the combined input-referred noise of the entire channel is 1.4 nV/√Hz at maximum gain. Assuming a 15 MHz noise bandwidth (NBW) and a 15.6 dB LNA gain, the input SNR is roughly 86 dB. In CW Doppler mode, the LNA output drives a transconductance amp that is switched through an 8 × 6 differential crosspoint switch. The switch is programmable through the SPI.

#### Rev. B

Information furnished by Analog Devices is believed to be accurate and reliable. However, no responsibility is assumed by Analog Devices for its use, nor for any infringements of patents or other rights of third parties that may result from its use. Specifications subject to change without notice. No license is granted by implication or otherwise under any patent or patent rights of Analog Devices. Trademarks and registered trademarks are the property of their respective owners.

## TABLE OF CONTENTS

Features .....	1	TGC Operation.....	25
Applications.....	1	ADC .....	27
General Description .....	1	Clock Input Considerations.....	28
Functional Block Diagram .....	1	Serial Port Interface (SPI).....	35
Revision History .....	2	Hardware Interface.....	35
Product Highlights .....	3	Memory Map .....	37
Specifications.....	4	Reading the Memory Map Table.....	37
AC Specifications.....	4	Reserved Locations .....	37
Digital Specifications .....	7	Default Values .....	37
Switching Specifications .....	8	Logic Levels.....	37
ADC Timing Diagrams .....	9	Applications Information .....	41
Absolute Maximum Ratings.....	10	Design Guidelines .....	41
Thermal Impedance .....	10	Evaluation Board .....	42
ESD Caution.....	10	Power Supplies.....	42
Pin Configuration and Function Descriptions.....	11	Input Signals.....	42
Equivalent Circuits .....	14	Output Signals .....	42
Typical Performance Characteristics .....	16	Default Operation and Jumper Selection Settings.....	43
Theory of Operation .....	20	Quick Start Procedure .....	44
Ultrasound.....	20	Schematics and Artwork .....	45
Channel Overview.....	21	Outline Dimensions .....	58
Input Overdrive .....	23	Ordering Guide .....	58
CW Doppler Operation.....	24		

## REVISION HISTORY

### 5/09—Rev. A to Rev. B

Changes to Figure 27.....	17
Changes to Figure 40 and Figure 41.....	21
Changes to Ordering Guide .....	58

### 12/07—Rev. 0 to Rev. A

Change to AC Specifications Text .....	4
Added Input Noise Current .....	4
Added Noise Figure.....	4
Changes to Signal-to-Noise Ratio Units.....	4
Changes to Harmonic Distortion Units .....	5
Added Endnote 3.....	6
Changes to Table 6.....	11
Inserted Figure 19 and Figure 21.....	16
Changes to Figure 20.....	16
Changes to Theory of Operation Section.....	20
Changes to Figure 40 and Figure 41 .....	21
Change to Active Impedance Matching Section .....	22

Changes to LNA Noise Section .....	22
Changes to Figure 43.....	22
Change to Input Overload Protection Section .....	23
Changes to TGC Operation Section .....	25
Changes to Gain Control Section.....	26
Changes to Figure 52.....	26
Change to Table 11 .....	33
Changes to Serial Interface Port (SPI) Section .....	35
Changes to Hardware Interface Section .....	35
Changes to Reading the Memory Map Table Section .....	37
Added Applications Information and Design Guidelines Sections.....	41
Change to Input Signals Section.....	42
Changes to Figure 73.....	42
Changes to Table 16 .....	55

### 6/07—Revision 0: Initial Version

The AD9271 requires a LVPECL-/CMOS-/LVDS-compatible sample rate clock for full performance operation. No external reference or driver components are required for many applications.

The ADC automatically multiplies the sample rate clock for the appropriate LVDS serial data rate. A data clock ( $DCO\pm$ ) for capturing data on the output and a frame clock ( $FCO\pm$ ) trigger for signaling a new output byte are provided.

Powering down individual channels is supported to increase battery life for portable applications. There is also a standby mode option that allows quick power-up for power cycling. In CW Doppler operation, the VGA, AAF, and ADC are powered down. The power of the TGC path scales with selectable speed grades.

The ADC contains several features designed to maximize flexibility and minimize system cost, such as a programmable clock, data alignment, and programmable digital test pattern generation. The digital test patterns include built-in fixed patterns, built-in pseudorandom patterns, and custom user-defined test patterns entered via the serial port interface.

Fabricated in an advanced CMOS process, the AD9271 is available in a 16 mm × 16 mm, RoHS compliant, 100-lead TQFP. It is specified over the industrial temperature range of  $-40^{\circ}\text{C}$  to  $+85^{\circ}\text{C}$ .

### **PRODUCT HIGHLIGHTS**

1. Small Footprint. Eight channels are contained in a small, space-saving package. Full TGC path, ADC, and crosspoint switch contained within a 100-lead, 16 mm × 16 mm TQFP.
2. Low Power of 150 mW per Channel at 40 MSPS.
3. Integrated Crosspoint Switch. This switch allows numerous multichannel configuration options to enable the CW Doppler mode.
4. Ease of Use. A data clock output ( $DCO\pm$ ) operates up to 300 MHz and supports double data rate (DDR) operation.
5. User Flexibility. Serial port interface (SPI) control offers a wide range of flexible features to meet specific system requirements.
6. Integrated Third-Order Antialiasing Filter. This filter is placed between the TGC path and the ADC and is programmable from 8 MHz to 18 MHz.

## SPECIFICATIONS

## AC SPECIFICATIONS

AVDD = 1.8 V, DRVDD = 1.8 V, CWVDD = 3.3 V, 1.0 V internal ADC reference,  $f_{IN} = 5$  MHz,  $R_S = 50 \Omega$ , LNA gain = 15.6 dB (6), AAF LPF cutoff =  $1/3 \times f_S$ , HPF cutoff = 700 kHz, full temperature, unless otherwise noted.

Table 1.

Parameter <sup>1</sup>	Conditions	AD9271-25			AD9271-40			AD9271-50			Unit	
		Min	Typ	Max	Min	Typ	Max	Min	Typ	Max		
LNA CHARACTERISTICS												
Gain = 5/6/8	Single-ended input to differential output	14/15.6/18			14/15.6/18			14/15.6/18			dB	
	Single-ended input to single-ended output	8/9.6/12			8/9.6/12			8/9.6/12			dB	
Input Voltage Range, Gain = 5/6/8	LNA output limited to 2 V p-p differential output	400/333/250			400/333/250			400/333/250			mV p-p SE <sup>2</sup>	
Input Common Mode		1.4			1.4			1.4			V	
Input Resistance	RFB = 200 $\Omega$	50			50			50			$\Omega$	
	RFB = 400 $\Omega$	100			100			100			$\Omega$	
	RFB = $\infty$	15			15			15			k $\Omega$	
Input Capacitance	LI-x	15			15			15			pF	
-3 dB Bandwidth		40			60			70			MHz	
Input Noise Current, Gain = 5/6/8		1.1			1.1			1.1			pA/ $\sqrt{\text{Hz}}$	
Input Noise Voltage, Gain = 5/6/8	$R_S = 0 \Omega$ , RFB = $\infty$	1.4/1.4/1.3			1.3/1.2/1.1			1.3/1.2/1.1			nV/ $\sqrt{\text{Hz}}$	
1 dB Input Compression Point, Gain = 5/6/8	$V_{\text{GAIN}} = 0$ V	770/650/495			770/650/495			770/650/495			mV p-p	
Noise Figure	Active Termination Match	$R_S = 50 \Omega$ , RFB = 200 $\Omega$	6.7			6.7			6.7			dB
			4.9			4.4			4.2			dB
FULL-CHANNEL (TGC) CHARACTERISTICS												
AAF High-Pass Cutoff	-3 dB	DC/350/700			DC/350/700			DC/350/700			kHz	
AAF Low-Pass Cutoff	-3 dB, programmable	$1/3 \times f_{\text{SAMPLE}}$ (8 to 18)			$1/3 \times f_{\text{SAMPLE}}$ (8 to 18)			$1/3 \times f_{\text{SAMPLE}}$ (8 to 18)			MHz	
Bandwidth Tolerance		$\pm 15$			$\pm 15$			$\pm 15$			%	
Group Delay Variation	$f = 1$ to 18 MHz, gain = 0 V to 1 V	$\pm 2$			$\pm 2$			$\pm 2$			ns	
Input-Referred Noise Voltage	LNA gain = 5/6/8, RFB = $\infty$	1.7/1.6/1.5			1.6/1.4/1.3			1.6/1.4/1.2			nV/ $\sqrt{\text{Hz}}$	
Correlated Noise Ratio	No signal, correlated/uncorrelated	-30			-30			-30			dB	
Output Offset	AAF high pass = 700 kHz	-50		+50	-35		+35	-35		+35	LSB	
Signal-to-Noise Ratio (SNR)	$V_{\text{GAIN}} = 0$ V	65.8			64.4			63.7			dBFS	
		62			59.7			59			dBFS	

Parameter <sup>1</sup>	Conditions	AD9271-25			AD9271-40			AD9271-50			Unit
		Min	Typ	Max	Min	Typ	Max	Min	Typ	Max	
Harmonic Distortion											
Second Harmonic $f_{IN} = 5$ MHz at $-7$ dBFS	$V_{GAIN} = 0$ V		-73			-71			-71		dBFS
Second Harmonic $f_{IN} = 5$ MHz at $-1$ dBFS	$V_{GAIN} = 1$ V		-80			-72			-68		dBFS
Third Harmonic $f_{IN} = 5$ MHz at $-7$ dBFS	$V_{GAIN} = 0$ V		-81			-77			-74		dBFS
Third Harmonic $f_{IN} = 5$ MHz at $-1$ dBFS	$V_{GAIN} = 1$ V		-65			-63			-66		dBFS
Two-Tone IMD3 ( $2 \times F1 - F2$ ) Distortion $f_{IN1} = 5.0$ MHz at $-7$ dBFS, $f_{IN2} = 6.0$ MHz at $-7$ dBFS	$V_{GAIN} = 1$ V		-54.6			-63.4			-68.5		dBc
Channel-to-Channel Crosstalk			-70			-70			-70		dB
Channel-to-Channel Crosstalk (Over- range Condition) <sup>3</sup>			-70			-70			-70		dB
Overload Recovery	Full TGC path, $f_{IN} = 1$ MHz to 10 MHz, gain = 0 V to 1 V		5			5			5		Degrees
<b>GAIN ACCURACY</b>	25°C										
Gain Law Confor- mance Error	$0 < V_{GAIN} < 0.1$ V		+0.8			+0.8			+0.8		dB
	$0.1$ V $< V_{GAIN} < 0.9$ V	-1.2		+1.2	-1.2		+1.2	-1.2		+1.2	dB
	$0.9$ V $< V_{GAIN} < 1$ V		-1.2			-1.2			-1.2		dB
Linear Gain Error	$V_{GAIN} = 0.5$ V, normalized for ideal AAF loss	-1.3		+1.3	-1.3		+1.3	-1.3		+1.3	dB
Channel-to-Channel Matching	$0.1$ V $< V_{GAIN} < 0.9$ V		0.2			0.2			0.2		dB
<b>GAIN CONTROL INTERFACE</b>											
Normal Operating Range		0		1	0		1	0		1	V
Gain Range	0 V to 1 V, normalized for ideal AAF loss		10 to 40			10 to 40			10 to 40		dB
Scale Factor			31.6			31.6			31.6		dB/V
Response Time	30 dB change		350			350			350		ns
<b>CW DOPPLER MODE</b>											
Transconductance Common Mode	LNA gain = 5/6/8 CW Doppler output pins	1.5	10/12/16	3.6	1.5	10/12/16	3.6	1.5	10/12/16	3.6	mA/V V
Input-Referred Noise Voltage	LNA gain = 5/6/8, $R_S = 0 \Omega$ , $R_{FB} = \infty$		1.8 / 1.7 / 1.5			1.7 / 1.5 / 1.4			1.7 / 1.5 / 1.3		nV/ $\sqrt{\text{Hz}}$
Output DC Bias	Per channel		2.4			2.4			2.4		mA
Maximum Output Swing	Per channel		$\pm 2$			$\pm 2$			$\pm 2$		mA p-p

# AD9271

Parameter <sup>1</sup>	Conditions	AD9271-25			AD9271-40			AD9271-50			Unit
		Min	Typ	Max	Min	Typ	Max	Min	Typ	Max	
POWER SUPPLY											
AVDD		1.7	1.8	1.9	1.7	1.8	1.9	1.7	1.8	1.9	V
DRVDD		1.7	1.8	1.9	1.7	1.8	1.9	1.7	1.8	1.9	V
CWVDD		3.0	3.3	3.6	3.0	3.3	3.6	3.0	3.3	3.6	
I <sub>AVDD</sub>	Full-channel mode		505			613			742		mA
	CW Doppler mode with four channels enabled		136			160			170		mA
I <sub>DRVDD</sub>			46.7			48.7			50		mA
Total Power Dissipation (Including Output Drivers)	Full-channel mode, no signal		993	1063		1190	1280		1425	1494	mW
	CW Doppler mode with four channels enabled		192			216			224		mW
Power-Down Dissipation				4.5			4.5			4.5	mW
Standby Power Dissipation				101.7			112.5			120.6	mW
Power Supply Rejection Ratio (PSRR)			1			1			1		mV/V
ADC RESOLUTION			12			12			12		Bits
ADC REFERENCE											
Output Voltage Error (V <sub>REF</sub> = 1 V)				±20			±20			±20	mV
Load Regulation @ 1.0 mA (V <sub>REF</sub> = 1 V)			3			3			3		mV
Input Resistance			6			6			6		kΩ

<sup>1</sup> See the AN-835 Application Note, *Understanding High Speed ADC Testing and Evaluation*, for a complete set of definitions and how these tests were completed.

<sup>2</sup> SE = single ended.

<sup>3</sup> The overrange condition is specified as being 6 dB more than the full-scale input range.

**DIGITAL SPECIFICATIONS**

AVDD = 1.8 V, DRVDD = 1.8 V, CWVDD = 3.3 V, 400 mV p-p differential input, 1.0 V internal ADC reference, AIN = -0.5 dBFS, unless otherwise noted.

**Table 2.**

Parameter <sup>1</sup>	Temperature	Min	Typ	Max	Unit
CLOCK INPUTS (CLK+, CLK-)					
Logic Compliance			CMOS/LVDS/LVPECL		
Differential Input Voltage <sup>2</sup>	Full	250			mV p-p
Input Common-Mode Voltage	Full		1.2		V
Input Resistance (Differential)	25°C		20		kΩ
Input Capacitance	25°C		1.5		pF
LOGIC INPUTS (PDWN, STBY, SCLK)					
Logic 1 Voltage	Full	1.2		3.6	V
Logic 0 Voltage	Full			0.3	V
Input Resistance	25°C		30		kΩ
Input Capacitance	25°C		0.5		pF
LOGIC INPUT (CSB)					
Logic 1 Voltage	Full	1.2		3.6	V
Logic 0 Voltage	Full			0.3	V
Input Resistance	25°C		70		kΩ
Input Capacitance	25°C		0.5		pF
LOGIC INPUT (SDIO)					
Logic 1 Voltage	Full	1.2		DRVDD + 0.3	V
Logic 0 Voltage	Full	0		0.3	V
Input Resistance	25°C		30		kΩ
Input Capacitance	25°C		2		pF
LOGIC OUTPUT (SDIO) <sup>3</sup>					
Logic 1 Voltage (I <sub>OH</sub> = 800 μA)	Full		1.79		V
Logic 0 Voltage (I <sub>OL</sub> = 50 μA)	Full			0.05	V
DIGITAL OUTPUTS (D+, D-), (ANSI-644) <sup>1</sup>					
Logic Compliance			LVDS		
Differential Output Voltage (V <sub>OD</sub> )	Full	247		454	mV
Output Offset Voltage (V <sub>OS</sub> )	Full	1.125		1.375	V
Output Coding (Default)			Offset binary		
DIGITAL OUTPUTS (D+, D-), (LOW POWER, REDUCED SIGNAL OPTION) <sup>1</sup>					
Logic Compliance			LVDS		
Differential Output Voltage (V <sub>OD</sub> )	Full	150		250	mV
Output Offset Voltage (V <sub>OS</sub> )	Full	1.10		1.30	V
Output Coding (Default)			Offset binary		

<sup>1</sup> See the AN-835 Application Note, *Understanding High Speed ADC Testing and Evaluation*, for a complete set of definitions and how these tests were completed.

<sup>2</sup> Specified for LVDS and LVPECL only.

<sup>3</sup> Specified for 13 SDIO pins sharing the same connection.

# AD9271

## SWITCHING SPECIFICATIONS

AVDD = 1.8 V, DRVDD = 1.8 V, CWVDD = 3.3 V, 400 mV p-p differential input, 1.0 V internal ADC reference, AIN = -0.5 dBFS, unless otherwise noted.

Table 3.

Parameter <sup>1</sup>	Temp	Min	Typ	Max	Unit
<b>CLOCK<sup>2</sup></b>					
Maximum Clock Rate	Full	50			MSPS
Minimum Clock Rate	Full			10	MSPS
Clock Pulse Width High ( $t_{EH}$ )	Full		10.0		ns
Clock Pulse Width Low ( $t_{EL}$ )	Full		10.0		ns
<b>OUTPUT PARAMETERS<sup>2, 3</sup></b>					
Propagation Delay ( $t_{PD}$ )	Full	1.5	2.3	3.1	ns
Rise Time ( $t_R$ ) (20% to 80%)	Full		300		ps
Fall Time ( $t_F$ ) (20% to 80%)	Full		300		ps
FCO Propagation Delay ( $t_{FCO}$ )	Full	1.5	2.3	3.1	ns
DCO Propagation Delay ( $t_{CPD}$ ) <sup>4</sup>	Full		$t_{FCO} + (t_{SAMPLE}/24)$		ns
DCO to Data Delay ( $t_{DATA}$ ) <sup>4</sup>	Full	$(t_{SAMPLE}/24) - 300$	$(t_{SAMPLE}/24)$	$(t_{SAMPLE}/24) + 300$	ps
DCO to FCO Delay ( $t_{FRAME}$ ) <sup>4</sup>	Full	$(t_{SAMPLE}/24) - 300$	$(t_{SAMPLE}/24)$	$(t_{SAMPLE}/24) + 300$	ps
Data-to-Data Skew ( $t_{DATA-MAX} - t_{DATA-MIN}$ )	Full		$\pm 50$	$\pm 200$	ps
Wake-Up Time (Standby), $V_{GAIN} = 0.5 V$	25°C		1		$\mu s$
Wake-Up Time (Power-Down)	25°C		1		ms
Pipeline Latency	Full		8		Clock cycles
<b>APERTURE</b>					
Aperture Uncertainty (Jitter)	25°C		<1		ps rms

<sup>1</sup> See the AN-835 Application Note, *Understanding High Speed ADC Testing and Evaluation*, for a complete set of definitions and how these tests were completed.

<sup>2</sup> Can be adjusted via the SPI interface.

<sup>3</sup> Measurements were made using a part soldered to FR-4 material.

<sup>4</sup>  $t_{SAMPLE}/24$  is based on the number of bits divided by 2, because the delays are based on half duty cycles.

ADC TIMING DIAGRAMS

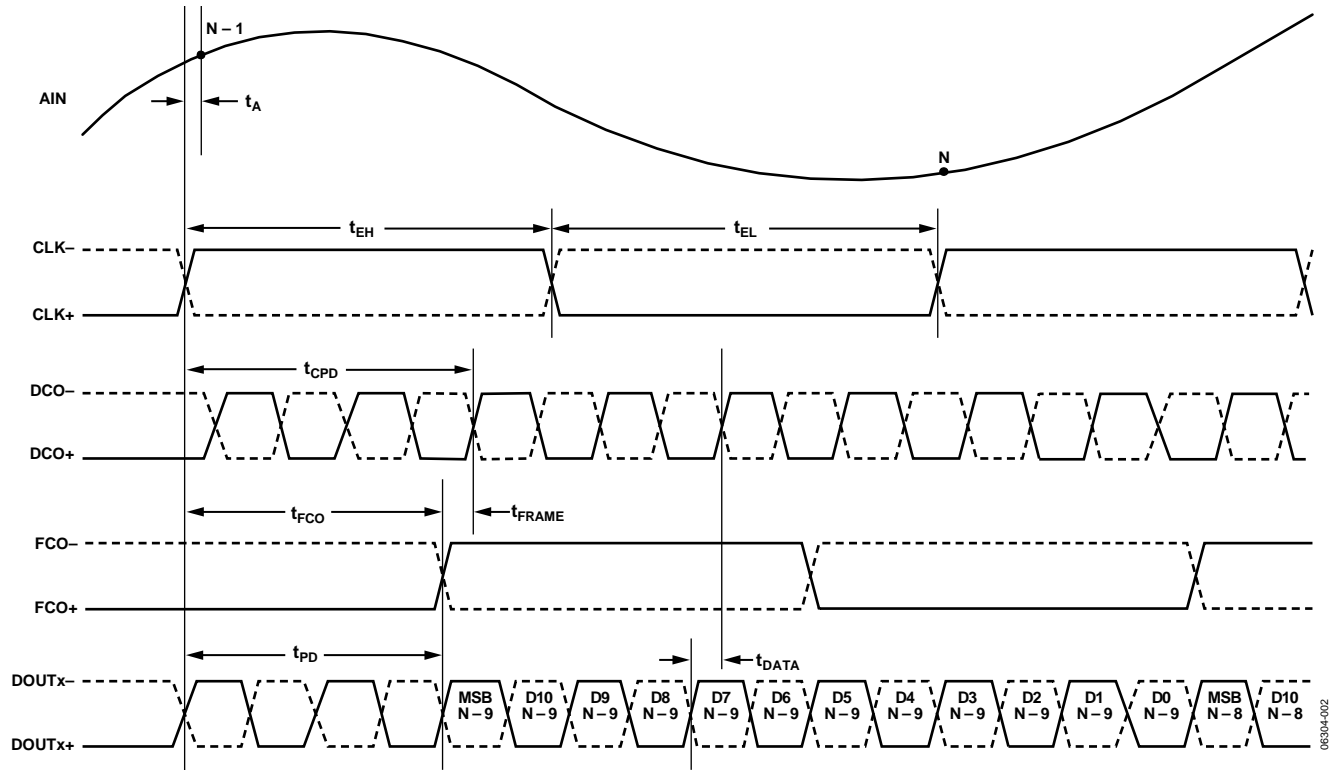

Figure 2. 12-Bit Data Serial Stream (Default)

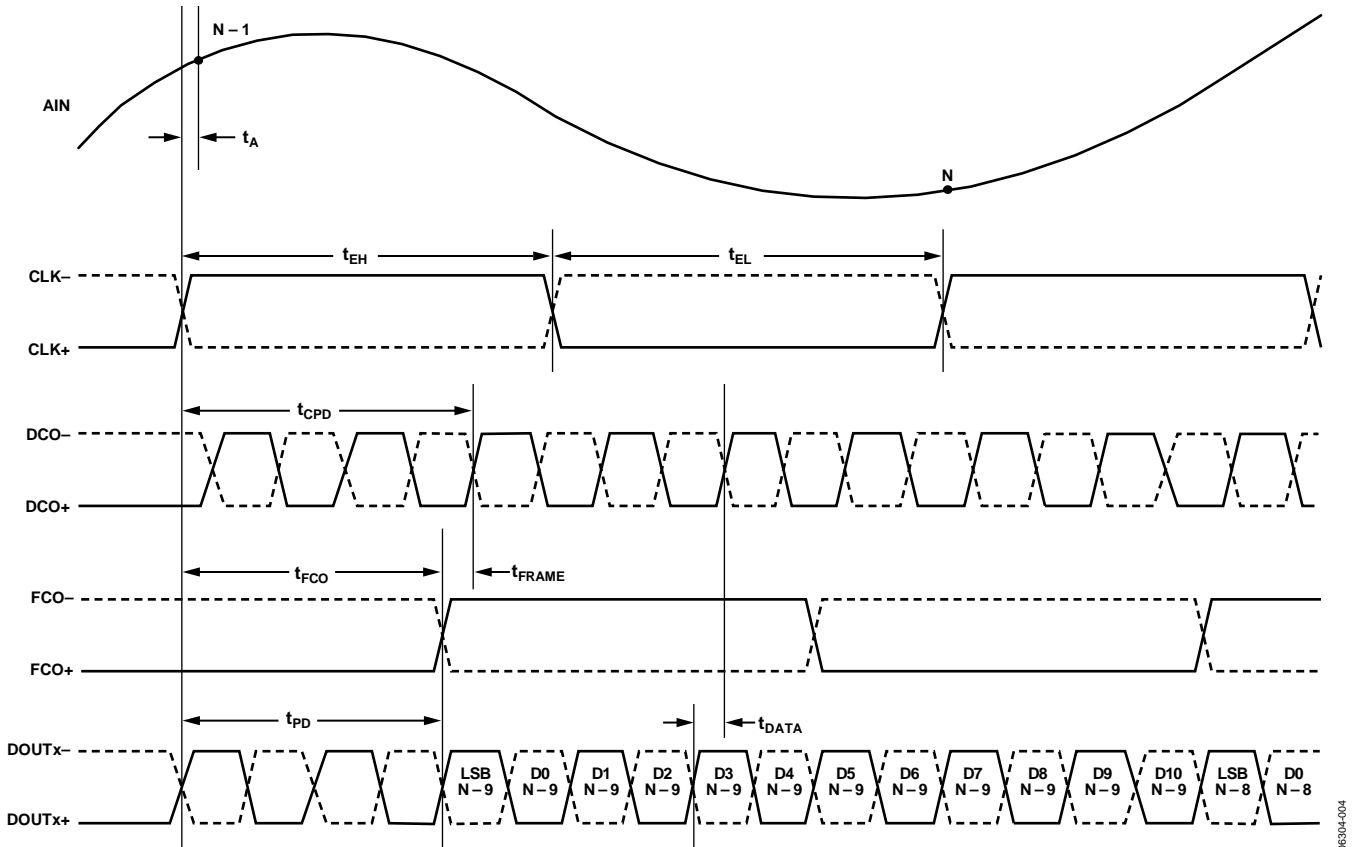

Figure 3. 12-Bit Data Serial Stream, LSB First

## ABSOLUTE MAXIMUM RATINGS

Table 4.

Parameter	With Respect To	Rating
<b>ELECTRICAL</b>		
AVDD	GND	-0.3 V to +2.0 V
DRVDD	GND	-0.3 V to +2.0 V
CWVDD	GND	-0.3 V to +3.9 V
GND	GND	-0.3 V to +0.3 V
AVDD	DRVDD	-2.0 V to +2.0 V
Digital Outputs (DOU <sub>Tx+</sub> , DOU <sub>Tx-</sub> , DCO <sub>+</sub> , DCO <sub>-</sub> , FCO <sub>+</sub> , FCO <sub>-</sub> )	GND	-0.3 V to +2.0 V
CLK <sub>+</sub> , CLK <sub>-</sub>	GND	-0.3 V to +3.9 V
LI-x	LG-x	-0.3 V to +2.0 V
LO-x	LG-x	-0.3 V to +2.0 V
LOSW-x	LG-x	-0.3 V to +2.0 V
CWD <sub>x-</sub> , CWD <sub>x+</sub>	GND	-0.3 V to +3.9 V
SDIO, GAIN <sub>+</sub> , GAIN <sub>-</sub>	GND	-0.3 V to +2.0 V
PDWN, STBY, SCLK, CSB	GND	-0.3 V to +3.9 V
REFT, REFB, RBIAS	GND	-0.3 V to +2.0 V
VREF, SENSE	GND	-0.3 V to +2.0 V
<b>ENVIRONMENTAL</b>		
Operating Temperature Range (Ambient)		-40°C to +85°C
Storage Temperature Range (Ambient)		-65°C to +150°C
Maximum Junction Temperature		150°C
Lead Temperature (Soldering, 10 sec)		300°C

Stresses above those listed under Absolute Maximum Ratings may cause permanent damage to the device. This is a stress rating only; functional operation of the device at these or any other conditions above those indicated in the operational section of this specification is not implied. Exposure to absolute maximum rating conditions for extended periods may affect device reliability.

### THERMAL IMPEDANCE

Table 5.

Air Flow Velocity (m/s)	$\theta_{JA}$ <sup>1</sup>	$\theta_{JB}$	$\theta_{JC}$	Unit
0.0	20.3			°C/W
1.0	14.4	7.6	4.7	°C/W
2.5	12.9			°C/W

<sup>1</sup>  $\theta_{JA}$  for a 4-layer PCB with solid ground plane (simulated). Exposed pad soldered to PCB.

### ESD CAUTION



**ESD (electrostatic discharge) sensitive device.** Charged devices and circuit boards can discharge without detection. Although this product features patented or proprietary protection circuitry, damage may occur on devices subjected to high energy ESD. Therefore, proper ESD precautions should be taken to avoid performance degradation or loss of functionality.

# PIN CONFIGURATION AND FUNCTION DESCRIPTIONS

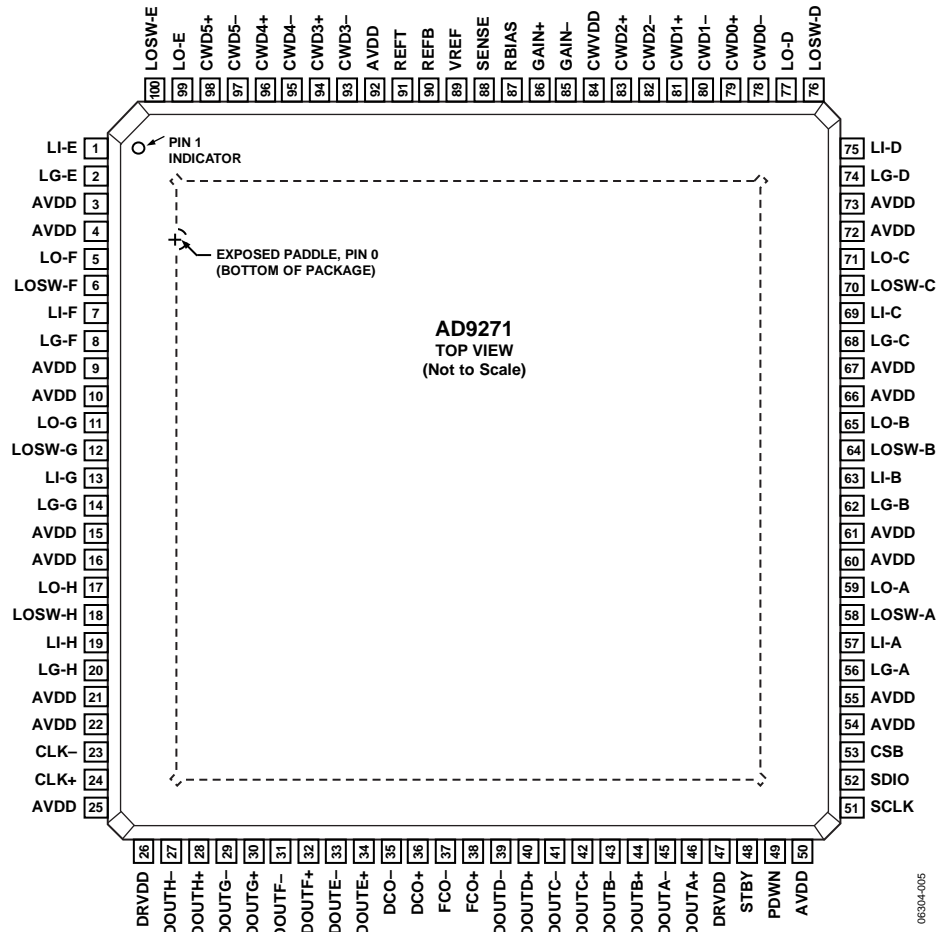

Figure 4. 100-Lead TQFP Pin Configuration

Table 6. Pin Function Descriptions

Pin No.	Name	Description
0	GND	Ground (exposed paddle should be tied to a quiet analog ground)
3, 4, 9, 10, 15, 16, 21, 22, 25, 50, 54, 55, 60, 61, 66, 67, 72, 73, 92	AVDD	1.8 V Analog Supply
26, 47	DRVDD	1.8 V Digital Output Driver Supply
84	CWVDD	3.3 V Analog Supply
1	LI-E	LNA Analog Input for Channel E
2	LG-E	LNA Ground for Channel E
5	LO-F	LNA Analog Output for Channel F
6	LOSW-F	LNA Analog Output Complement for Channel F
7	LI-F	LNA Analog Input for Channel F
8	LG-F	LNA Ground for Channel F
11	LO-G	LNA Analog Output for Channel G
12	LOSW-G	LNA Analog Output Complement for Channel G
13	LI-G	LNA Analog Input for Channel G
14	LG-G	LNA Ground for Channel G
17	LO-H	LNA Analog Output for Channel H

# AD9271

Pin No.	Name	Description
18	LOSW-H	LNA Analog Output Complement for Channel H
19	LI-H	LNA Analog Input for Channel H
20	LG-H	LNA Ground for Channel H
23	CLK-	Clock Input Complement
24	CLK+	Clock Input True
27	DOUTH-	ADC H Digital Output Complement
28	DOUTH+	ADC H Digital Output True
29	DOUTG-	ADC G Digital Output Complement
30	DOUTG+	ADC G Digital Output True
31	DOUTF-	ADC F Digital Output Complement
32	DOUTF+	ADC F Digital Output True
33	DOUTE-	ADC E Digital Output Complement
34	DOUTE+	ADC E Digital Output True
35	DCO-	Data Clock Digital Output Complement
36	DCO+	Data Clock Digital Output True
37	FCO-	Frame Clock Digital Output Complement
38	FCO+	Frame Clock Digital Output True
39	DOUTD-	ADC D Digital Output Complement
40	DOUTD+	ADC D Digital Output True
41	DOUTC-	ADC C Digital Output Complement
42	DOUTC+	ADC C Digital Output True
43	DOUTB-	ADC B Digital Output Complement
44	DOUTB+	ADC B Digital Output True
45	DOUTA-	ADC A Digital Output Complement
46	DOUTA+	ADC A Digital Output True
48	STBY	Standby Power-Down
49	PDWN	Full Power-Down
51	SCLK	Serial Clock
52	SDIO	Serial Data Input/Output
53	CSB	Chip Select Bar
56	LG-A	LNA Ground for Channel A
57	LI-A	LNA Analog Input for Channel A
58	LOSW-A	LNA Analog Output Complement for Channel A
59	LO-A	LNA Analog Output for Channel A
62	LG-B	LNA Ground for Channel B
63	LI-B	LNA Analog Input for Channel B
64	LOSW-B	LNA Analog Output Complement for Channel B
65	LO-B	LNA Analog Output for Channel B
68	LG-C	LNA Ground for Channel C
69	LI-C	LNA Analog Input for Channel C
70	LOSW-C	LNA Analog Output Complement for Channel C
71	LO-C	LNA Analog Output for Channel C
74	LG-D	LNA Ground for Channel D
75	LI-D	LNA Analog Input for Channel D
76	LOSW-D	LNA Analog Output Complement for Channel D
77	LO-D	LNA Analog Output for Channel D
78	CWD0-	CW Doppler Output Complement for Channel 0
79	CWD0+	CW Doppler Output True for Channel 0
80	CWD1-	CW Doppler Output Complement for Channel 1
81	CWD1+	CW Doppler Output True for Channel 1
82	CWD2-	CW Doppler Output Complement for Channel 2
83	CWD2+	CW Doppler Output True for Channel 2
85	GAIN-	Gain Control Voltage Input Complement

Pin No.	Name	Description
86	GAIN+	Gain Control Voltage Input True
87	RBIAS	External Resistor to Set the Internal ADC Core Bias Current
88	SENSE	Reference Mode Selection
89	VREF	Voltage Reference Input/Output
90	REFB	Differential Reference (Negative)
91	REFT	Differential Reference (Positive)
93	CWD3-	CW Doppler Output Complement for Channel 3
94	CWD3+	CW Doppler Output True for Channel 3
95	CWD4-	CW Doppler Output Complement for Channel 4
96	CWD4+	CW Doppler Output True for Channel 4
97	CWD5-	CW Doppler Output Complement for Channel 5
98	CWD5+	CW Doppler Output True for Channel 5
99	LO-E	LNA Analog Output for Channel E
100	LOSW-E	LNA Analog Output Complement for Channel E

EQUIVALENT CIRCUITS

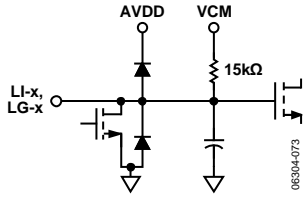

Figure 5. Equivalent LNA Input Circuit

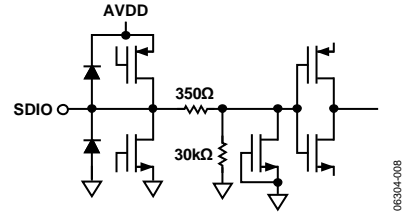

Figure 8. Equivalent SDIO Input Circuit

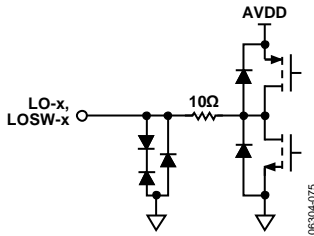

Figure 6. Equivalent LNA Output Circuit

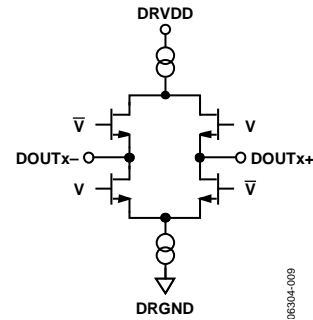

Figure 9. Equivalent Digital Output Circuit

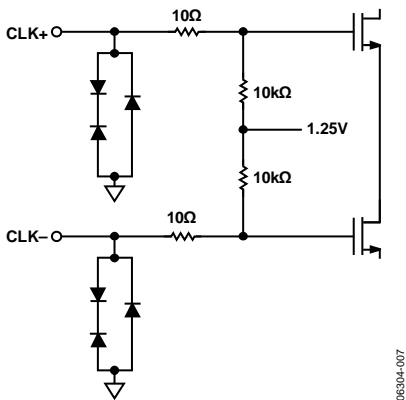

Figure 7. Equivalent Clock Input Circuit

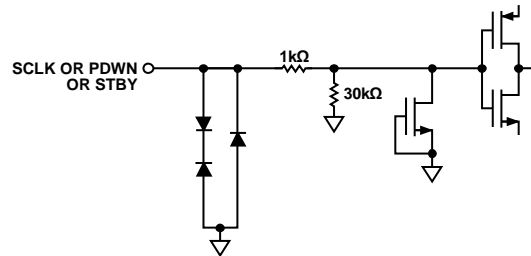

Figure 10. Equivalent SCLK Input Circuit

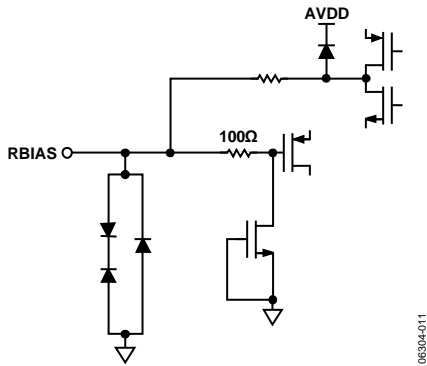

Figure 11. Equivalent RBIAS Circuit

06304-011

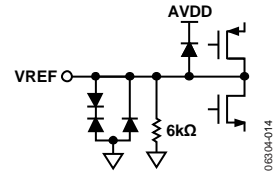

Figure 14. Equivalent VREF Circuit

06304-014

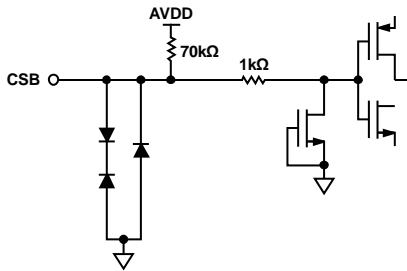

Figure 12. Equivalent CSB Input Circuit

06304-012

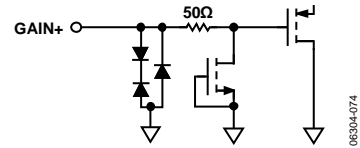

Figure 15. Equivalent GAIN+ Input Circuit

06304-074

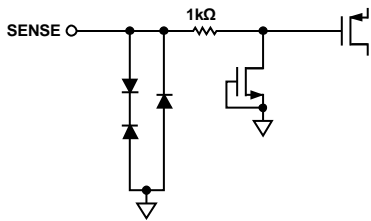

Figure 13. Equivalent SENSE Circuit

06304-013

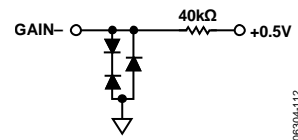

Figure 16. Equivalent GAIN- Input Circuit

06304-112

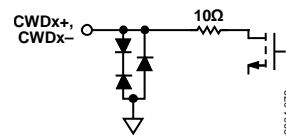

Figure 17. Equivalent CWDx± Output Circuit

06304-076

# TYPICAL PERFORMANCE CHARACTERISTICS

$f_{\text{SAMPLE}} = 50 \text{ MSPS}$ ,  $f_{\text{IN}} = 5 \text{ MHz}$ ,  $\text{LPF} = 1/3 \times f_{\text{SAMPLE}}$ ,  $\text{HPF} = 700 \text{ kHz}$ ,  $\text{LNA gain} = 6\times$ .

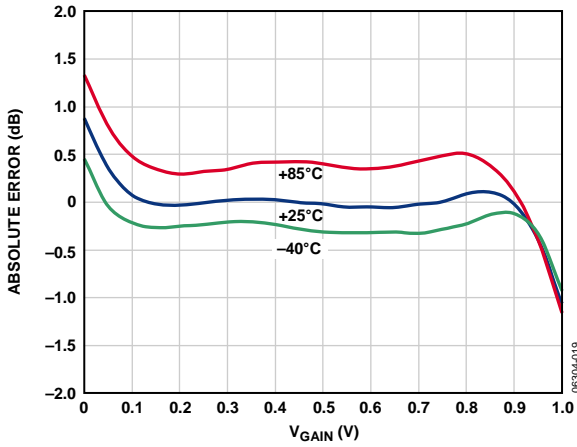

Figure 18. Gain Error vs.  $V_{\text{GAIN}}$  at Three Temperatures

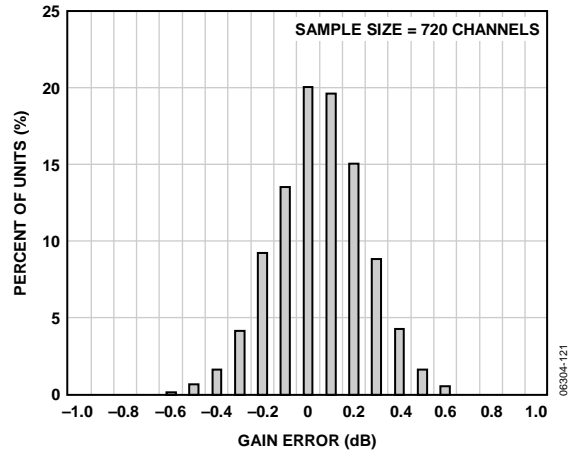

Figure 21. Gain Error Histogram with  $V_{\text{GAIN}} = 0.9 \text{ V}$

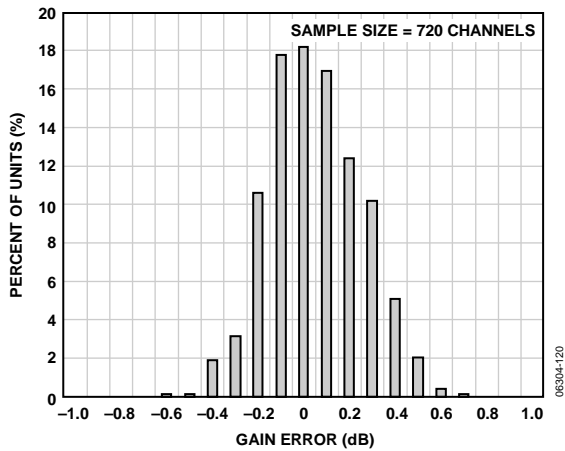

Figure 19. Gain Error Histogram with  $V_{\text{GAIN}} = 0.1 \text{ V}$

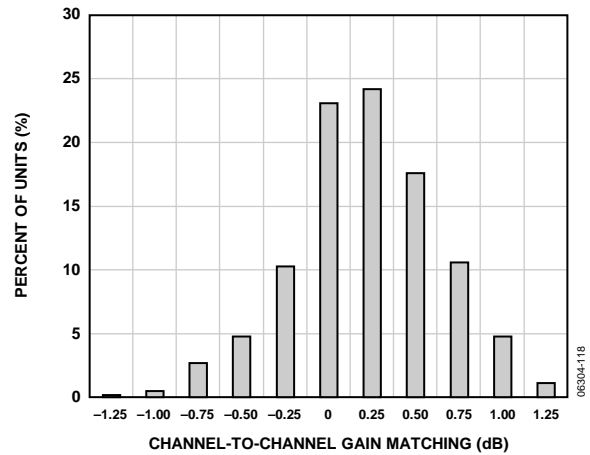

Figure 22. Gain Match Histogram for  $V_{\text{GAIN}} = 0.2 \text{ V}$

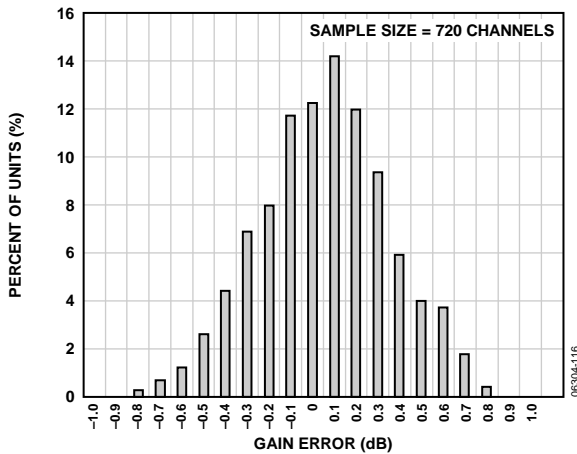

Figure 20. Gain Error Histogram with  $V_{\text{GAIN}} = 0.5 \text{ V}$

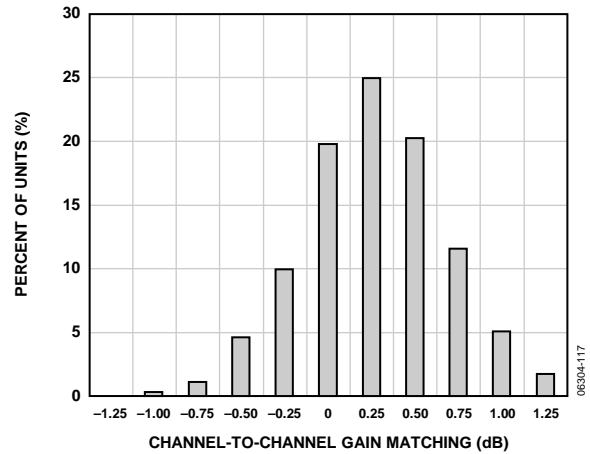

Figure 23. Gain Match Histogram for  $V_{\text{GAIN}} = 0.8 \text{ V}$

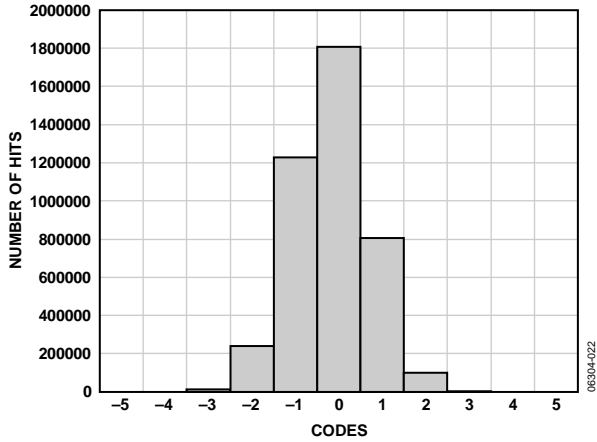

Figure 24. Output-Referred Noise Histogram with  $V_{GAIN} = 0.0 V$

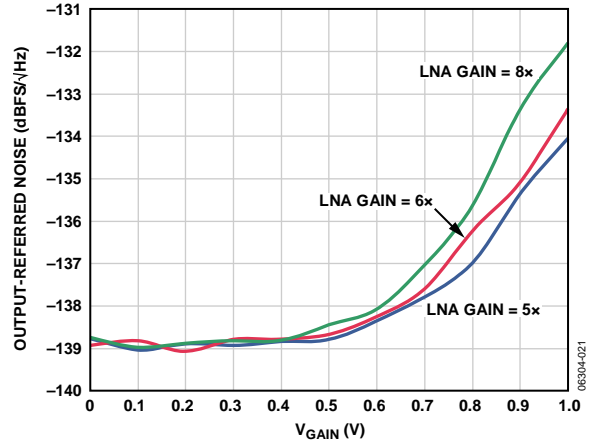

Figure 27. Short-Circuit, Output-Referred Noise vs.  $V_{GAIN}$

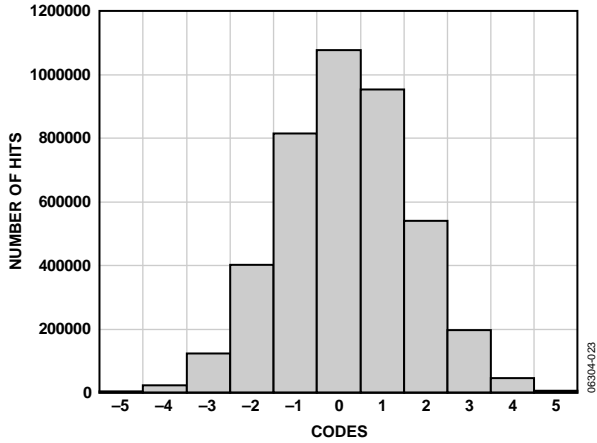

Figure 25. Output-Referred Noise Histogram with  $V_{GAIN} = 1.0 V$

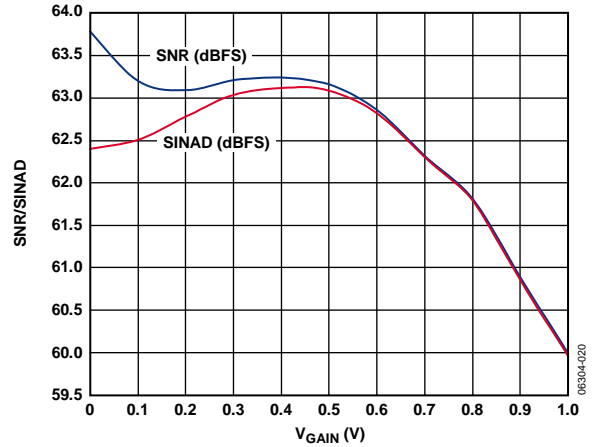

Figure 28. SNR/SINAD vs.  $V_{GAIN}$ ,  $A_{IN} = -6.5 \text{ dBFS}$

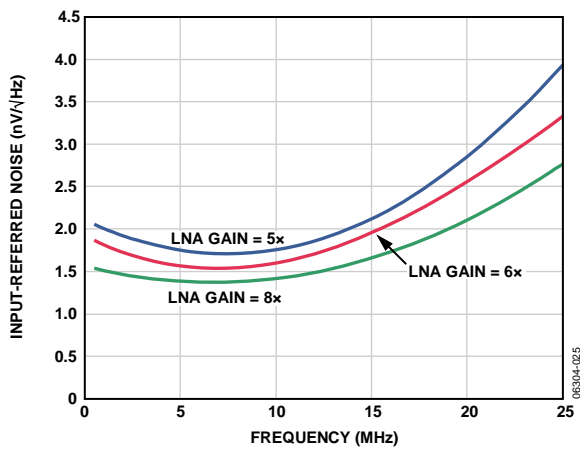

Figure 26. Short-Circuit, Input-Referred Noise vs. Frequency

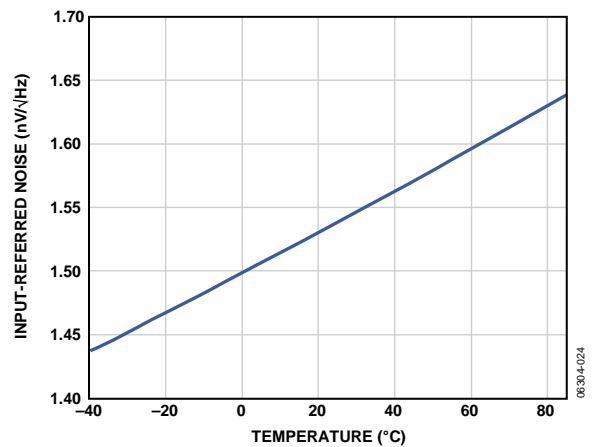

Figure 29. Short-Circuit, Input-Referred Noise vs. Temperature

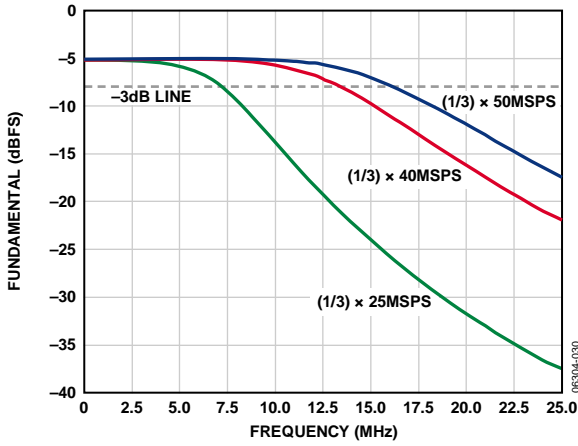

Figure 30. Antialiasing Filter (AAF) Pass-Band Response, No HPF Applied

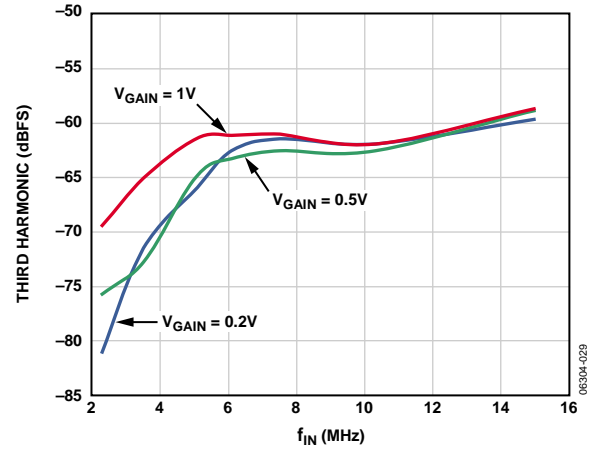

Figure 33. Third-Order Harmonic Distortion vs. Frequency, AIN = -0.5 dBFS

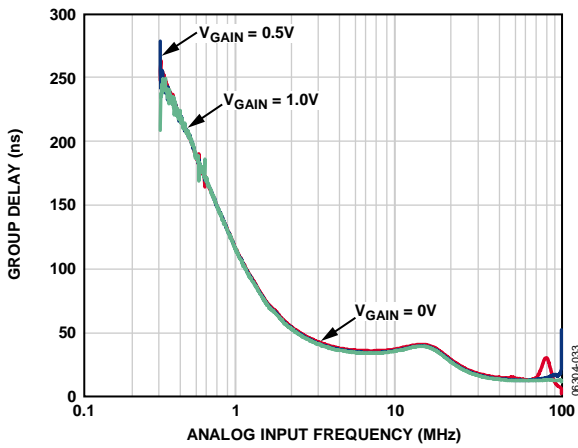

Figure 31. Antialiasing Filter (AAF) Group Delay Response

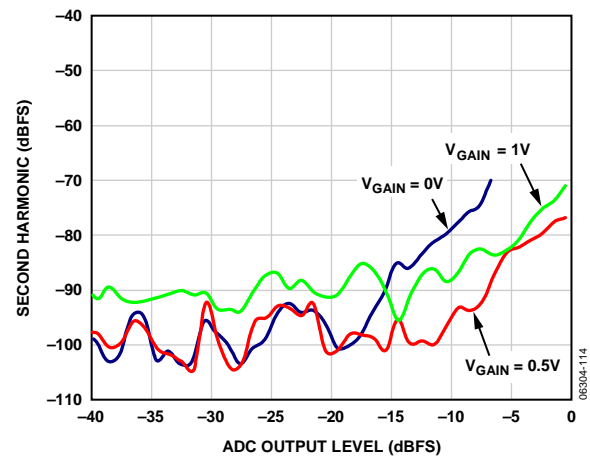

Figure 34. Second-Order Harmonic Distortion vs. ADC Output Level

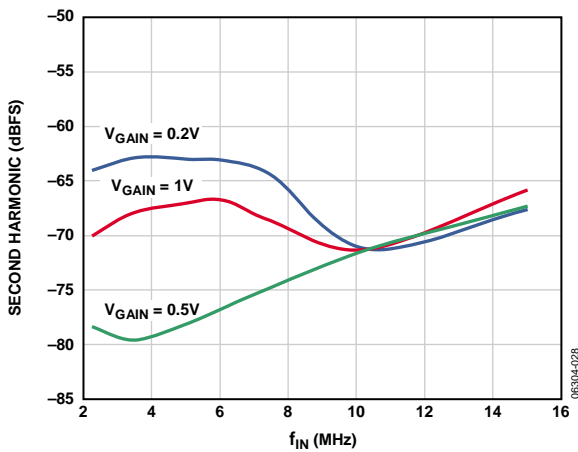

Figure 32. Second-Order Harmonic Distortion vs. Frequency, AIN = -0.5 dBFS

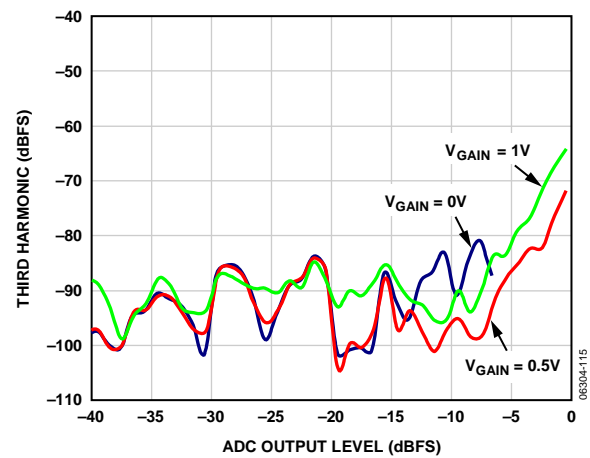

Figure 35. Third-Order Harmonic Distortion vs. ADC Output Level

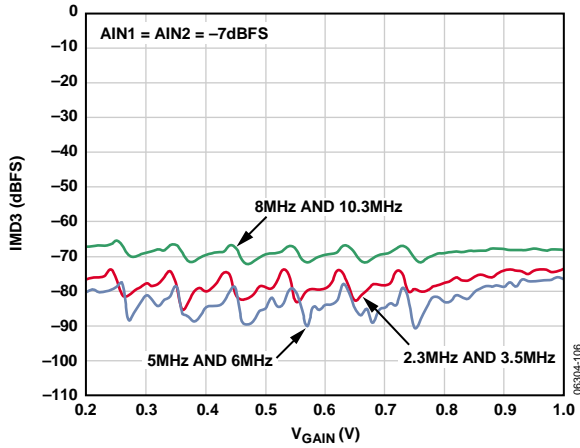

Figure 36. IMD3 vs.  $V_{GAIN}$

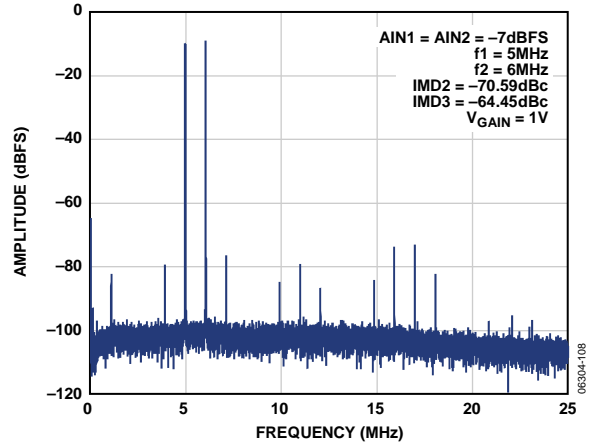

Figure 38. Typical IMD3 and IMD2 Performance

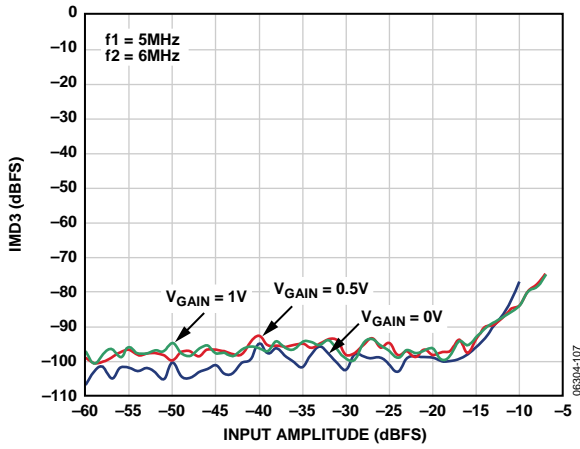

Figure 37. IMD3 vs. Amplitude

## THEORY OF OPERATION

### ULTRASOUND

The primary application for the AD9271 is medical ultrasound. Figure 39 shows a simplified block diagram of an ultrasound system. A critical function of an ultrasound system is the time gain control (TGC) compensation for physiological signal attenuation. Because the attenuation of ultrasound signals is exponential with respect to distance (time), a linear-in-dB VGA is the optimal solution.

Key requirements in an ultrasound signal chain are very low noise, active input termination, fast overload recovery, low power, and differential drive to an ADC. Because ultrasound machines use beam-forming techniques requiring large binary-weighted numbers (for example, 32 to 512) of channels, the lowest power at the lowest possible noise is of key importance.

Most modern machines use digital beam forming. In this technique, the signal is converted to digital format immediately

following the TGC amplifier, and then beam forming is accomplished digitally.

The ADC resolution of 12 bits with up to 50 MSPS sampling satisfies the requirements of both general-purpose and high-end systems.

Power consumption and low cost are of primary importance in low-end and portable ultrasound machines, and the AD9271 is designed for these criteria.

For additional information regarding ultrasound systems, refer to “How Ultrasound System Considerations Influence Front-End Component Choice,” *Analog Dialogue*, Volume 36, Number 3, May–July 2002, and “The AD9271—A Revolutionary Solution for Portable Ultrasound,” *Analog Dialogue*, Volume 41, Number 7, July 2007.

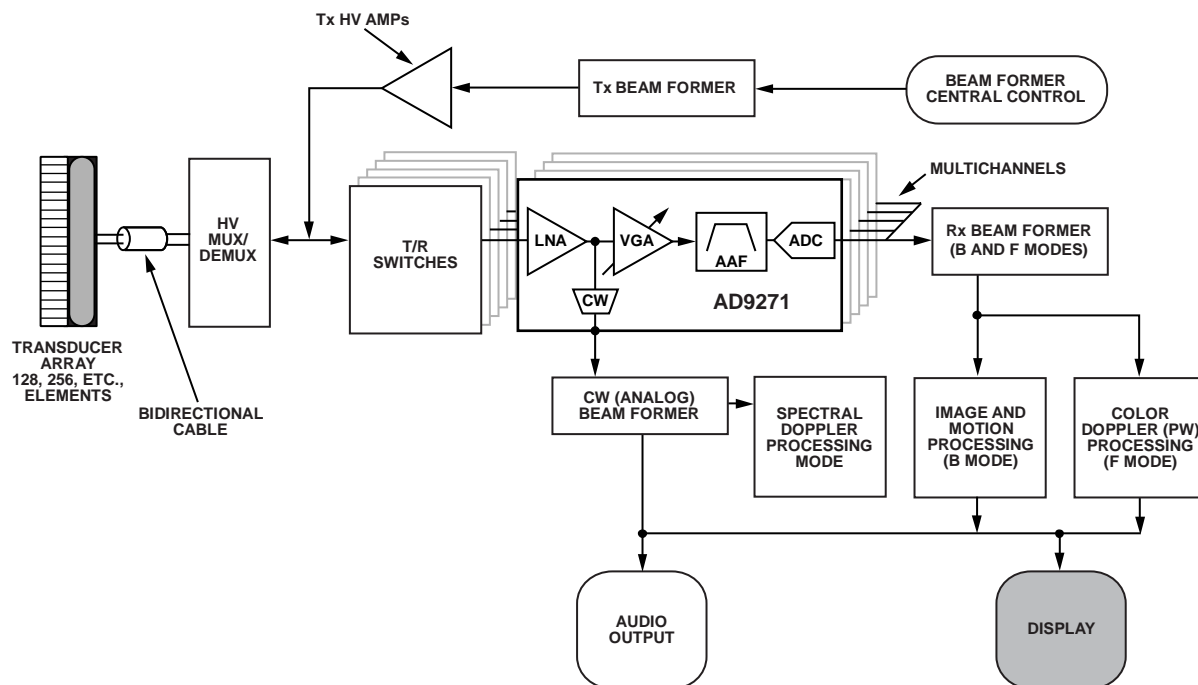

Figure 39. Simplified Ultrasound System Block Diagram

08304-077

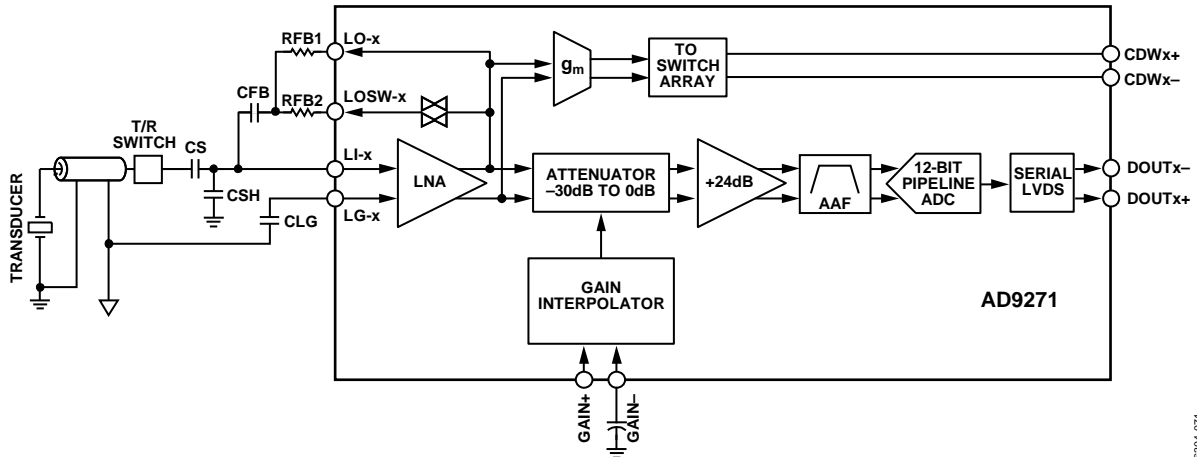

Figure 40. Simplified Block Diagram of a Single Channel

06304-071

## CHANNEL OVERVIEW

Each channel contains both a TGC signal path and a CW Doppler signal path. Common to both signal paths, the LNA provides user-adjustable input impedance termination. The CW Doppler path includes a transconductance amplifier and a crosspoint switch. The TGC path includes a differential X-AMP<sup>®</sup> VGA, an antialiasing filter, and an ADC. Figure 40 shows a simplified block diagram with external components.

The signal path is fully differential throughout to maximize signal swing and reduce even-order distortion; however, the LNA is designed to be driven from a single-ended signal source.

### Low Noise Amplifier (LNA)

Good noise performance relies on a proprietary ultralow noise LNA at the beginning of the signal chain, which minimizes the noise contribution in the following VGA. Active impedance control optimizes noise performance for applications that benefit from input impedance matching.

A simplified schematic of the LNA is shown in Figure 41. LI-x is capacitively coupled to the source. An on-chip bias generator establishes dc input bias voltages of around 1.4 V and centers the output common-mode levels at 0.9 V ( $V_{DD}/2$ ). A capacitor, CLG, of the same value as the input coupling capacitor, CS, is connected from the LG-x pin to ground.

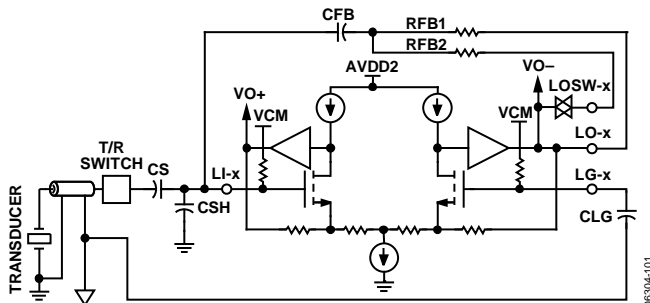

Figure 41. Simplified LNA Schematic

06304-101

The LNA supports differential output voltages as high as 2 V p-p with positive and negative excursions of  $\pm 0.5$  V from a common-mode voltage of 0.9 V. The LNA differential gain sets the maximum input signal before saturation. One of three gains is set through the SPI. The corresponding input full scale for the gain settings of 5, 6, or 8 is 400 mV p-p, 333 mV p-p, and 250 mV p-p, respectively. Overload protection ensures quick recovery time from large input voltages. Because the inputs are capacitively coupled to a bias voltage near midsupply, very large inputs can be handled without interacting with the ESD protection.

Low value feedback resistors and the current-driving capability of the output stage allow the LNA to achieve a low input-referred noise voltage of 1.2 nV/ $\sqrt{\text{Hz}}$ . This is achieved with a current consumption of only 16 mA per channel (30 mW). On-chip resistor matching results in precise single-ended gains, which are critical for accurate impedance control. The use of a fully differential topology and negative feedback minimizes distortion. Low HD2 is particularly important in second-harmonic ultrasound imaging applications. Differential signaling enables smaller swings at each output, further reducing third-order distortion.

### Active Impedance Matching

The LNA consists of a single-ended voltage gain amplifier with differential outputs and the negative output externally available. For example, with a fixed gain of  $6\times$  (15.6 dB), an active input termination is synthesized by connecting a feedback resistor between the negative output pin, LO-x, and the positive input pin, LI-x. This technique is well known and results in the input resistance shown in Equation 1:

$$R_{IN} = \frac{R_{FB}}{(1 + A/2)} \quad (1)$$

where  $A/2$  is the single-ended gain or the gain from the LI-x inputs to the LO-x outputs.

Because the amplifier has a gain of  $6\times$  from its input to its differential output, it is important to note that the gain  $A/2$  is the gain from Pin LI-x to Pin LO-x, and it is 6 dB less than the gain of the amplifier, or 9.6 dB ( $3\times$ ). The input resistance is reduced by an internal bias resistor of 15 k $\Omega$  in parallel with the source resistance connected to Pin LI-x, with Pin LG-x ac grounded. Equation 2 can be used to calculate the needed  $R_{FB}$  for a desired  $R_{IN}$ , even for higher values of  $R_{IN}$ .

$$R_{IN} = \frac{R_{FB}}{(1+3)} \parallel 15\text{ k}\Omega \quad (2)$$

For example, to set  $R_{IN}$  to 200  $\Omega$ , the value of  $R_{FB}$  is 845  $\Omega$ . If the simplified equation (Equation 2) is used to calculate  $R_{IN}$ , the value is 190  $\Omega$ , resulting in a gain error less than 0.5 dB. Some factors, such as the presence of a dynamic source resistance, might influence the absolute gain accuracy more significantly. At higher frequencies, the input capacitance of the LNA needs to be considered. The user must determine the level of matching accuracy and adjust  $R_{FB}$  accordingly.

The bandwidth (BW) of the LNA is about 70 MHz. Ultimately the BW of the LNA limits the accuracy of the synthesized  $R_{IN}$ . For  $R_{IN} = R_s$  up to about 200  $\Omega$ , the best match is between 100 kHz and 10 MHz, where the lower frequency limit is determined by the size of the ac-coupling capacitors, and the upper limit is determined by the LNA BW. Furthermore, the input capacitance and  $R_s$  limit the BW at higher frequencies. Figure 42 shows  $R_{IN}$  vs. frequency for various values of  $R_{FB}$ .

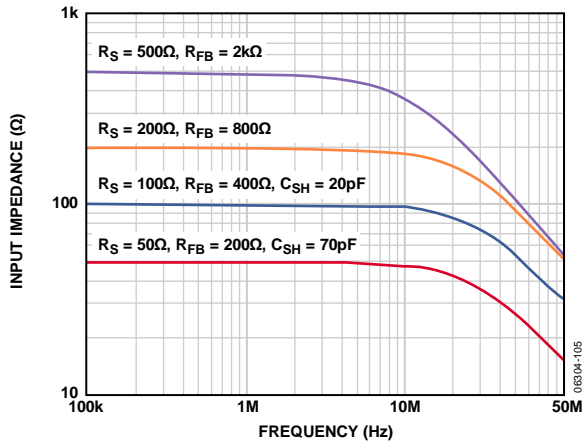

Figure 42.  $R_{IN}$  vs. Frequency for Various Values of  $R_{FB}$  (Effects of  $R_{SH}$  and  $C_{SH}$  Are Also Shown)

Note that at the lowest value, 50  $\Omega$ , in Figure 42,  $R_{IN}$  peaks at frequencies greater than 10 MHz. This is due to the BW roll-off of the LNA, as mentioned previously.

However, as can be seen for larger  $R_{IN}$  values, parasitic capacitance starts rolling off the signal BW before the LNA can produce peaking.  $C_{SH}$  further degrades the match; therefore,  $C_{SH}$  should not be used for values of  $R_{IN}$  that are greater than 100  $\Omega$ . Table 7 lists the recommended values for  $R_{FB}$  and  $C_{SH}$  in terms of  $R_{IN}$ .

$C_{FB}$  is needed in series with  $R_{FB}$  because the dc levels at Pin LO-x and Pin LI-x are unequal.

Table 7. Active Termination External Component Values

LNA Gain	$R_{IN}$ ( $\Omega$ )	$R_{FB}$ ( $\Omega$ )	Minimum $C_{SH}$ (pF)	BW (MHz)
5 $\times$	50	175	90	49
6 $\times$	50	200	70	59
8 $\times$	50	250	50	73
5 $\times$	100	350	30	49
6 $\times$	100	400	20	59
8 $\times$	100	500	10	73
5 $\times$	200	700	N/A	49
6 $\times$	200	800	N/A	49
8 $\times$	200	1000	N/A	49

### LNA Noise

The short-circuit noise voltage (input-referred noise) is an important limit on system performance. The short-circuit noise voltage for the LNA is 1.2 nV/ $\sqrt{\text{Hz}}$  or 1.4 nV/ $\sqrt{\text{Hz}}$  (at 15.6 dB LNA gain), including the VGA noise. These measurements, which were taken without a feedback resistor, provide the basis for calculating the input noise and noise figure (NF) performance of the configurations shown in Figure 43. Figure 44 and Figure 45 are simulations of noise figure vs.  $R_s$  results using these configurations and an input-referred noise voltage of 4 nV/ $\sqrt{\text{Hz}}$  for the VGA. Underterminated ( $R_{FB} = \infty$ ) operation exhibits the lowest equivalent input noise and noise figure. Figure 45 shows the noise figure vs. source resistance rising at low  $R_s$ —where the LNA voltage noise is large compared with the source noise—and at high  $R_s$  due to the noise contribution from  $R_{FB}$ . The lowest NF is achieved when  $R_s$  matches  $R_{IN}$ .

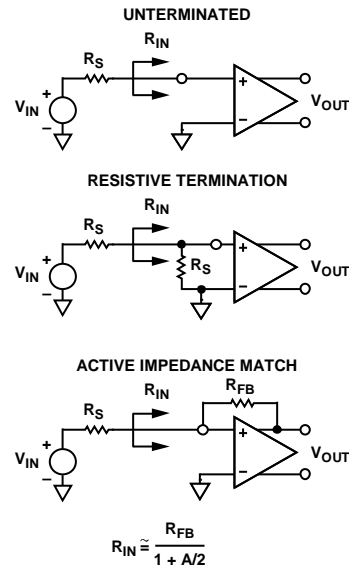

Figure 43. Input Configurations

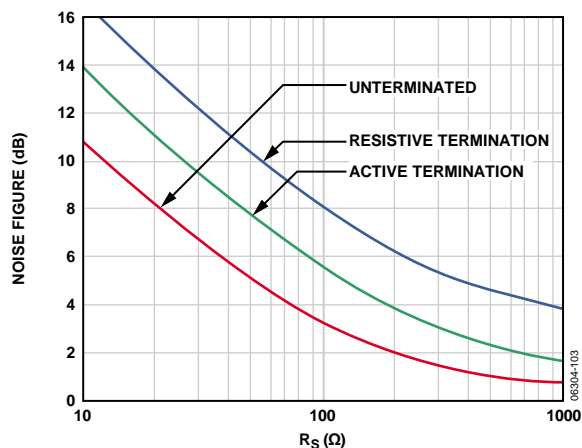

Figure 44. Noise Figure vs.  $R_S$  for Resistive Termination, Active Termination Matched, and Unterminated Inputs,  $V_{Gain} = 1\text{ V}$ , 15.6 dB LNA Gain

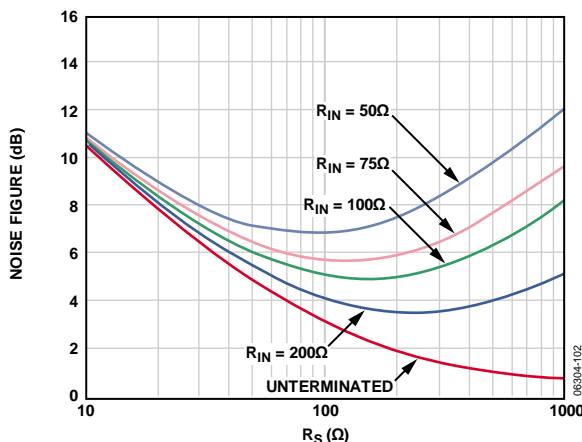

Figure 45. Noise Figure vs.  $R_S$  for Various Fixed Values of  $R_{IN}$ , Active Termination Matched Inputs,  $V_{Gain} = 1\text{ V}$ , 15.6 dB LNA Gain

The primary purpose of input impedance matching is to improve the transient response of the system. With resistive termination, the input noise increases due to the thermal noise of the matching resistor and the increased contribution of the LNA's input voltage noise generator. With active impedance matching, however, the contributions of both are smaller (by a factor of  $1/(1 + \text{LNA Gain})$ ) than they would be for resistive termination. Figure 44 shows the relative noise figure performance. In this graph, the input impedance was swept with  $R_S$  to preserve the match at each point. The noise figures for a source impedance of 50  $\Omega$  are 7.1 dB, 4.1 dB, and 2.5 dB for the resistive termination, active termination, and unterminated configurations, respectively. The noise figures for 200  $\Omega$  are 4.6 dB, 2.0 dB, and 1.0 dB, respectively.

Figure 45 shows the noise figure as it relates to  $R_S$  for various values of  $R_{IN}$ , which is helpful for design purposes.

## INPUT OVERDRIVE

Excellent overload behavior is of primary importance in ultrasound. Both the LNA and VGA have built-in overload protection and quickly recover after an overload event.

### Input Overload Protection

As with any amplifier, voltage clamping prior to the inputs is highly recommended if the application is subject to high transient voltages.

A block diagram of a simplified ultrasound transducer interface is shown in Figure 46. A common transducer element serves the dual functions of transmitting and receiving ultrasound energy. During the transmitting phase, high voltage pulses are applied to the ceramic elements. A typical transmit/receive (T/R) switch can consist of four high voltage diodes in a bridge configuration. Although the diodes ideally block transmit pulses from the sensitive receiver input, diode characteristics are not ideal, and resulting leakage transients imposed on the LI-x inputs can be problematic.

Because ultrasound is a pulse system and time-of-flight is used to determine depth, quick recovery from input overloads is essential. Overload can occur in the preamp and the VGA. Immediately following a transmit pulse, the typical VGA gains are low, and the LNA is subject to overload from T/R switch leakage. With increasing gain, the VGA can become overloaded due to strong echoes that occur near field echoes and acoustically dense materials, such as bone.

Figure 46 illustrates an external overload protection scheme. A pair of back-to-back Schottky diodes is installed prior to installing the ac-coupling capacitors. Although the BAS40 diodes are shown, any diode is prone to exhibiting some amount of shot noise. Many types of diodes are available for achieving the desired noise performance. The configuration shown in Figure 46 tends to add  $2\text{ nV}/\sqrt{\text{Hz}}$  of input-referred noise. Decreasing the 5 k $\Omega$  resistor and increasing the 2 k $\Omega$  resistor may improve noise contribution, depending on the application. With the diodes shown in Figure 46, clamping levels of  $\pm 0.5\text{ V}$  or less significantly enhance the overload performance of the system.

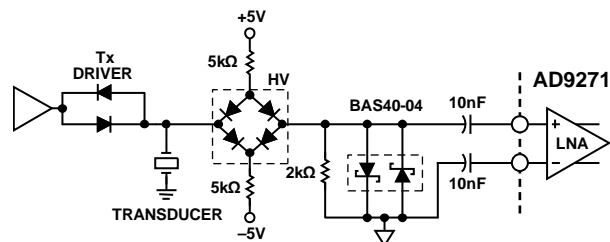

Figure 46. Input Overload Protection

# AD9271

## CW DOPPLER OPERATION

Modern ultrasound machines used for medical applications employ a  $2^N$  binary array of receivers for beam forming, with typical array sizes of 16 or 32 receiver channels phase-shifted and summed together to extract coherent information. When used in multiples, the desired signals from each channel can be summed to yield a larger signal (increased by a factor N, where N is the number of channels), and the noise is increased by the square root of the number of channels. This technique enhances the signal-to-noise performance of the machine. The critical elements in a beam-former design are the means to align the incoming signals in the time domain and the means to sum the individual signals into a composite whole.

Beam forming, as applied to medical ultrasound, is defined as the phase alignment and summation of signals that are generated from a common source but received at different times by a multielement ultrasound transducer. Beam forming has two functions: it imparts directivity to the transducer, enhancing its

gain, and it defines a focal point within the body from which the location of the returning echo is derived.

The AD9271 includes the front-end components needed to implement analog beam forming for CW Doppler operation. These components allow CW channels with similar phases to be coherently combined before phase alignment and down mixing, thus reducing the number of delay lines or adjustable phase shifters/down mixers (AD8333 or AD8339) required. Next, if delay lines are used, the phase alignment is performed and then the channels are coherently summed and down converted by a dynamic range I/Q demodulator. Alternatively, if phase shifters/down mixers, such as the AD8333 and AD8339, are used, phase alignment and downconversion are done before coherently summing all channels into I/Q signals. In either case, the resultant I and Q signals are filtered and sampled by two high resolution ADCs, and the sampled signals are processed to extract the relevant Doppler information.

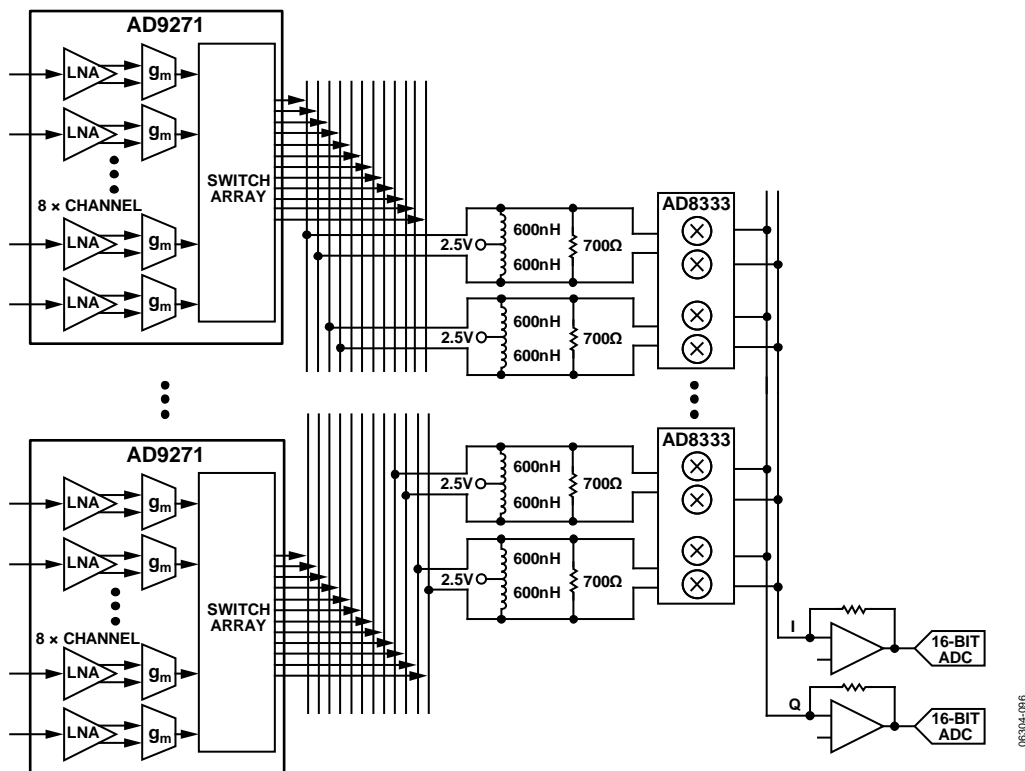

Figure 47. Typical CW Doppler System Using the AD9271 and AD8333 or AD8339

### Crosspoint Switch

Each LNA is followed by a transconductance amp for V/I conversion. Currents can be routed to one of six pairs of differential outputs or to 12 single-ended outputs for summing. Each CWD output pin sinks 2.4 mA dc current, and the signal has a full-scale current of  $\pm 2$  mA for each channel selected by the crosspoint switch. For example, if four channels were to be summed on one CWD output, the output would sink 9.6 mA dc and have a full-scale current output of  $\pm 8$  mA. The maximum number of channels combined must be considered when setting the load impedance for I/V conversion to ensure that the full-scale swing and common-mode voltage are within the operating limits of the AD9271. When interfacing to the AD8339, a common-mode voltage of 2.5 V and a full-scale swing of 2.8 V p-p are desired. This can be accomplished by connecting an inductor between each CWD output and a 2.5 V supply, and then connecting either a single-ended or differential load resistance to the CWD $\pm$  outputs. The value of resistance should be calculated based on the maximum number of channels that can be combined.

CWD $\pm$  outputs are required under full-scale swing to be greater than 1.5 V and less than CWVDD (3.3 V supply).

### TGC OPERATION

The TGC signal path is fully differential throughout to maximize signal swing and reduce even-order distortion; however, the LNAs are designed to be driven from a single-ended signal source. Gain values are referenced from the single-ended LNA input to the differential ADC input. A simple exercise in understanding the maximum and minimum gain requirements is shown in Figure 48.

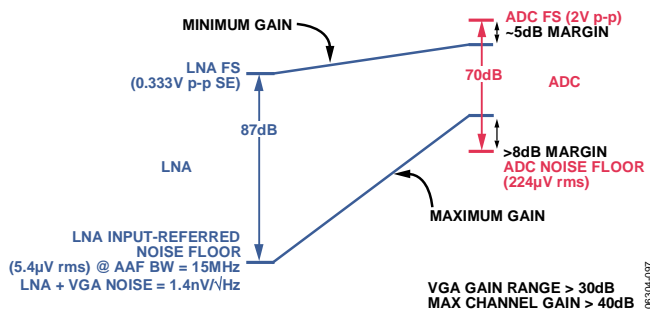

Figure 48. Gain Requirements of TGC for a 12-Bit, 40 MSPS ADC

In summary, the maximum gain required is determined by

$$(ADC\ Noise\ Floor/VGA\ Input\ Noise\ Floor) + Margin = 20 \log(224/5.4) + 8\ dB = 40.3\ dB$$

The minimum gain required is determined by

$$(ADC\ Input\ FS/VGA\ Input\ FS) + Margin = 20 \log(2/0.333) - 5\ dB = 10.6\ dB$$

Therefore, a 12-bit, 40 MSPS ADC with 15 MHz of bandwidth should suffice in achieving the dynamic range required for most of today's ultrasound systems.

The system gain is distributed as listed in Table 8.

Table 8. Channel Gain Distribution

Section	Nominal Gain (dB)
LNA	14/15.6/18
Attenuator	0 to -30
VGA Amp	24
Filter	0
ADC	0
Total	8.4 to 38.4/10 to 40/12.4 to 42.4

The linear-in-dB gain (law conformance) range of the TGC path is 30 dB, extending from 10 dB to 40 dB. The slope of the gain control interface is 31.6 dB/V, and the gain control range is 0 V to 1 V as specified in Equation 3. Equation 4 is the expression for channel gain.

$$V_{GAIN}(V) = (GAIN+) - (GAIN-) + 0.5 \quad (3)$$

$$Gain(dB) = 31.6 \frac{dB}{V} V_{GAIN} + ICPT \quad (4)$$

where  $ICPT$  is the intercept point of the TGC gain.

In its default condition, the LNA has a gain of 15.6 dB (6 $\times$ ) and the VGA gain is -6 dB if the voltage on the GAIN $\pm$  pins is 0 V. This gives rise to a total gain (or  $ICPT$ ) of 10 dB through the TGC path if the LNA input is unmatched, or of 4 dB if the LNA is matched to 50  $\Omega$  ( $R_{FB} = 200\ \Omega$ ). If the voltage on the GAIN $\pm$  pins is 1 V, however, the VGA gain is 24 dB. This gives rise to a total gain of 40 dB through the TGC path if the LNA input is unmatched, or of 34 dB if the LNA input is matched.

Each LNA output is dc-coupled to a VGA input. The VGA consists of an attenuator with a range of 30 dB followed by an amplifier with 24 dB of gain for a net gain range of -6 dB to +24 dB. The X-AMP gain-interpolation technique results in low gain error and uniform bandwidth, and differential signal paths minimize distortion.

At low gains, the VGA should limit the system noise performance (SNR); at high gains, the noise is defined by the source and LNA. The maximum voltage swing is bound by the full-scale peak-to-peak ADC input voltage (2 V p-p).

Both the LNA and VGA have limitations within each section of the TGC path, depending on the voltage applied to the GAIN+ and GAIN- pins. The LNA has three limitations, or full-scale settings, depending on the gain selection applied through the SPI interface. When a voltage of 0.2 V or less is applied to the GAIN $\pm$  pins, the LNA operates near the full-scale input range to maximize the dynamic range of the ADC without clipping the signal. When more than 0.2 V is applied to the GAIN $\pm$  pins, the input signal to the LNA must be lowered to keep it within the full-scale range of the ADC (see Figure 49).

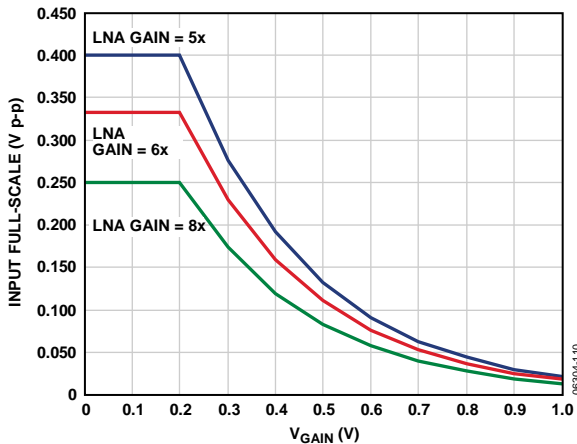

Figure 49. LNA/VGA Full-Scale Limitations

## Variable Gain Amplifier

The differential X-AMP VGA provides precise input attenuation and interpolation. It has a low input-referred noise of 4 nV/ $\sqrt{\text{Hz}}$  and excellent gain linearity. A simplified block diagram is shown in Figure 50.

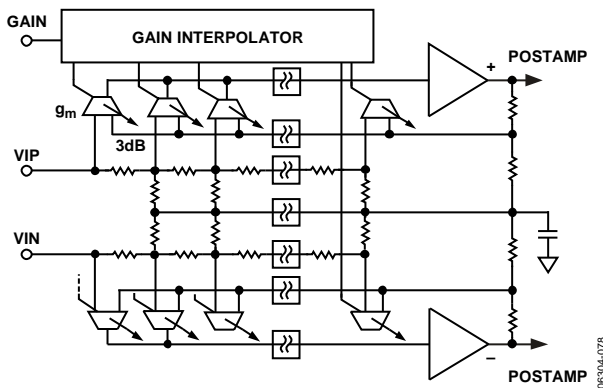

Figure 50. Simplified VGA Schematic

The input of the VGA is a 12-stage differential resistor ladder with 3.01 dB per tap. The resulting total gain range is 30 dB, which allows for range loss at the endpoints. The effective input resistance per side is 180  $\Omega$  nominally for a total differential resistance of 360  $\Omega$ . The ladder is driven by a fully differential input signal from the LNA. LNA outputs are dc-coupled to avoid external decoupling capacitors. The common-mode voltage of the attenuator and the VGA is controlled by an amplifier that uses the same midsupply voltage derived in the LNA, permitting dc coupling of the LNA to the VGA without introducing large offsets due to common-mode differences. However, any offset from the LNA will be amplified as the gain is increased, producing an exponentially increasing VGA output offset.

The input stages of the X-AMP are distributed along the ladder, and a biasing interpolator, controlled by the gain interface, determines the input tap point. With overlapping bias currents, signals from successive taps merge to provide a smooth attenuation range from 0 dB to -30 dB. This circuit technique results in linear-in-dB gain law conformance and low distortion levels—only deviating  $\pm 0.5$  dB or less from the ideal. The gain

slope is monotonic with respect to the control voltage and is stable with variations in process, temperature, and supply.

The X-AMP inputs are part of a 24 dB gain feedback amplifier that completes the VGA. Its bandwidth is about 70 MHz. The input stage is designed to reduce feedthrough to the output and to ensure excellent frequency response uniformity across the gain setting.

## Gain Control

The gain control interface, GAIN $\pm$ , is a differential input. The VGA gain, V<sub>GAIN</sub>, is shown in Equation 3. V<sub>GAIN</sub> varies the gain of all VGAs through the interpolator by selecting the appropriate input stages connected to the input attenuator. The nominal V<sub>GAIN</sub> range for 30 dB/V is 0 V to 1 V, with the best gain linearity from about 0.1 V to 0.9 V, where the error is typically less than  $\pm 0.5$  dB. For V<sub>GAIN</sub> voltages greater than 0.9 V and less than 0.1 V, the error increases. The value of V<sub>GAIN</sub> can exceed the supply voltage by 1 V without gain foldover.

Gain control response time is less than 750 ns to settle within 10% of the final value for a change from minimum to maximum gain.

There are two ways in which the GAIN+ and GAIN- pins can be interfaced. Using a single-ended method, a Kelvin type of connection to ground can be used as shown in Figure 51. For driving multiple devices, it is preferable to use a differential method, as shown in Figure 52. In either method, the GAIN+ and GAIN- pins should be dc-coupled and driven to accommodate a 1 V full-scale input.

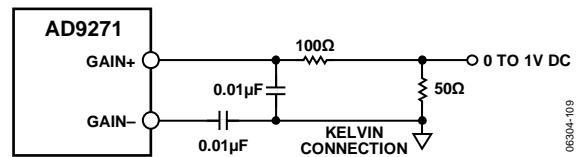

Figure 51. Single-Ended GAIN $\pm$  Pins Configuration

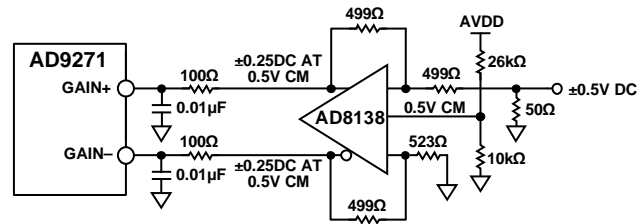

Figure 52. Differential GAIN $\pm$  Pins Configuration

## VGA Noise

In a typical application, a VGA compresses a wide dynamic range input signal to within the input span of an ADC. The input-referred noise of the LNA limits the minimum resolvable input signal, whereas the output-referred noise, which depends primarily on the VGA, limits the maximum instantaneous dynamic range that can be processed at any one particular gain control voltage. This latter limit is set in accordance with the total noise floor of the ADC.

Output-referred noise as a function of V<sub>GAIN</sub> is shown in Figure 24 and Figure 25 for the short-circuit input conditions. The input

noise voltage is simply equal to the output noise divided by the measured gain at each point in the control range.

The output-referred noise is a flat  $63 \text{ nV}/\sqrt{\text{Hz}}$  over most of the gain range, because it is dominated by the fixed output-referred noise of the VGA. At the high end of the gain control range, the noise of the LNA and source prevail. The input-referred noise reaches its minimum value near the maximum gain control voltage, where the input-referred contribution of the VGA is miniscule.

At lower gains, the input-referred noise and, therefore, the noise figure increases as the gain decreases. The instantaneous dynamic range of the system is not lost, however, because the input capacity increases as the input-referred noise increases. The contribution of the ADC noise floor has the same dependence. The important relationship is the magnitude of the VGA output noise floor relative to that of the ADC.

Gain control noise is a concern in very low noise applications. Thermal noise in the gain control interface can modulate the channel gain. The resultant noise is proportional to the output signal level and is usually evident only when a large signal is present. The gain interface includes an on-chip noise filter, which significantly reduces this effect at frequencies above 5 MHz. Care should be taken to minimize noise impinging at the  $\text{GAIN}\pm$  input. An external RC filter can be used to remove  $V_{\text{GAIN}}$  source noise. The filter bandwidth should be sufficient to accommodate the desired control bandwidth.

### Antialiasing Filter

The filter that the signal reaches prior to the ADC is used to reject dc signals and to band limit the signal for antialiasing. Figure 53 shows the architecture of the filter.

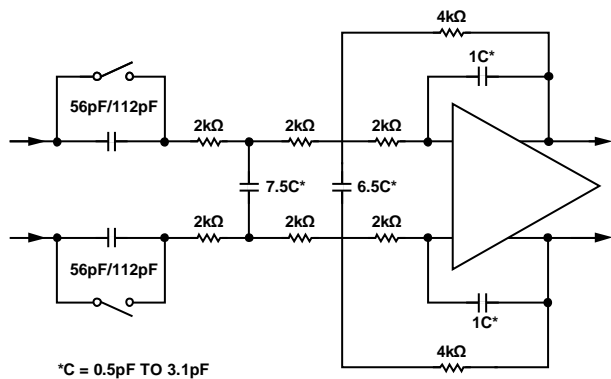

Figure 53. Simplified Filter Schematic

The filter can be configured for dc coupling or to have a single pole for high-pass filtering at either 700 kHz or 350 kHz (programmed through the SPI). The high-pass pole, however, is not tuned and can vary by  $\pm 30\%$ .

A third-order Butterworth low-pass filter is used to reduce noise bandwidth and provide antialiasing for the ADC. The filter uses on-chip tuning to trim the capacitors and in turn set the desired cutoff frequency and reduce variations. The default  $-3 \text{ dB}$  cutoff is  $1/3$  the ADC sample clock rate. The cutoff can be scaled to 0.7, 0.8, 0.9, 1, 1.1, 1.2, or 1.3 times this frequency through the SPI. The cutoff can be set from 8 MHz to 18 MHz.

Tuning is normally off to avoid changing the capacitor settings during critical times. The tuning circuit is enabled and disabled through the SPI. Initializing the tuning of the filter must be done after initial power-up and after reprogramming the filter cutoff scaling or ADC sample rate. Occasional retuning during an idle time is recommended to compensate for temperature drift.

### ADC

The AD9271 architecture consists of a pipelined ADC divided into three sections: a 4-bit first stage followed by eight 1.5-bit stages and a 3-bit flash. Each stage provides sufficient overlap to correct for flash errors in the preceding stages. The quantized outputs from each stage are combined into a 12-bit result in the digital correction logic. The pipelined architecture permits the first stage to operate on a new input sample and the remaining stages to operate on preceding samples. Sampling occurs on the rising edge of the clock.

Each stage of the pipeline except for the last consists of a low resolution flash ADC connected to a switched-capacitor DAC and interstage residue amplifier (for example, a multiplying digital-to-analog converter (MDAC)). The residue amplifier magnifies the difference between the reconstructed DAC output and the flash input for the next stage in the pipeline. One bit of redundancy is used in each stage to facilitate digital correction of flash errors. The last stage consists of a flash ADC.

The output staging block aligns the data, carries out error correction, and passes the data to the output buffers. The data is then serialized and aligned to the frame and output clock.

# AD9271

## CLOCK INPUT CONSIDERATIONS

For optimum performance, the AD9271 sample clock inputs (CLK+ and CLK-) should be clocked with a differential signal. This signal is typically ac-coupled into the CLK+ and CLK- pins via a transformer or capacitors. These pins are biased internally and require no additional bias.

Figure 54 shows the preferred method for clocking the AD9271. A low jitter clock source, such as the Valpey Fisher oscillator VFAC3-BHL-50MHz, is converted from single-ended to differential using an RF transformer. The back-to-back Schottky diodes across the secondary transformer limit clock excursions into the AD9271 to approximately 0.8 V p-p differential. This helps prevent the large voltage swings of the clock from feeding through to other portions of the AD9271, and it preserves the fast rise and fall times of the signal, which are critical to low jitter performance.

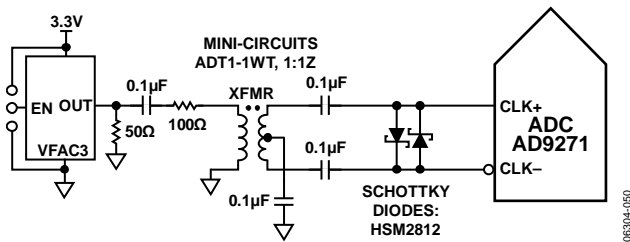
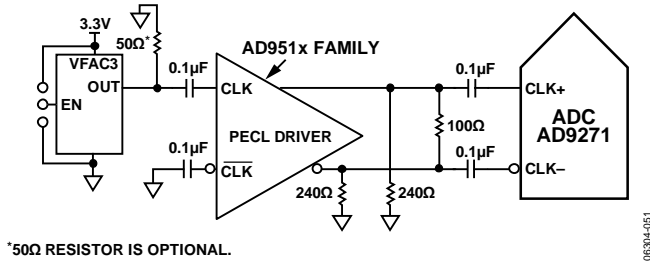

Figure 54. Transformer-Coupled Differential Clock

If a low jitter clock is available, another option is to ac-couple a differential PECL signal to the sample clock input pins as shown in Figure 55. The AD951x family of clock drivers offers excellent jitter performance.



\*50Ω RESISTOR IS OPTIONAL.

Figure 55. Differential PECL Sample Clock

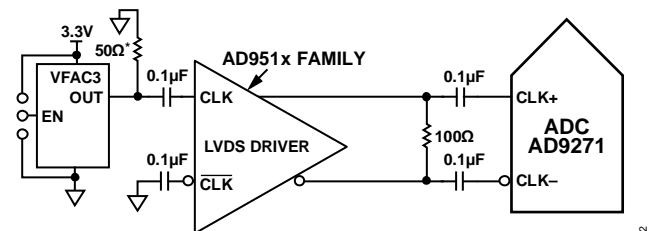

\*50Ω RESISTOR IS OPTIONAL.

Figure 56. Differential LVDS Sample Clock

In some applications, it is acceptable to drive the sample clock inputs with a single-ended CMOS signal. In such applications, CLK+ should be driven directly from a CMOS gate, and the CLK- pin should be bypassed to ground with a 0.1 μF capacitor in parallel with a 39 kΩ resistor (see Figure 57). Although the CLK+ input circuit supply is AVDD (1.8 V), this input is designed to withstand input voltages of up to 3.3 V, making the selection of the drive logic voltage very flexible.

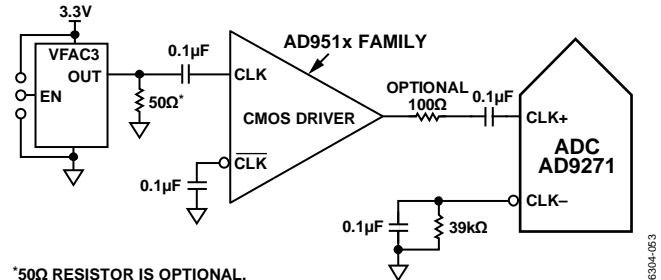

\*50Ω RESISTOR IS OPTIONAL.

Figure 57. Single-Ended 1.8 V CMOS Sample Clock

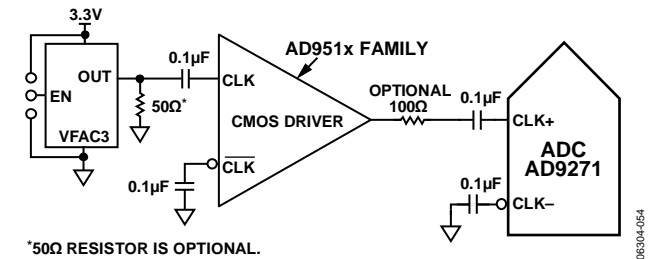

\*50Ω RESISTOR IS OPTIONAL.

Figure 58. Single-Ended 3.3 V CMOS Sample Clock

## Clock Duty Cycle Considerations

Typical high speed ADCs use both clock edges to generate a variety of internal timing signals. As a result, these ADCs may be sensitive to the clock duty cycle. Commonly, a 5% tolerance is required on the clock duty cycle to maintain dynamic performance characteristics. The AD9271 contains a duty cycle stabilizer (DCS) that retimes the nonsampling edge, providing an internal clock signal with a nominal 50% duty cycle. This allows a wide range of clock input duty cycles without affecting the performance of the AD9271. When the DCS is on, noise and distortion performance are nearly flat for a wide range of duty cycles. However, some applications may require the DCS function to be off. If so, keep in mind that the dynamic range performance can be affected when operated in this mode. See the Memory Map section for more details on using this feature.

The duty cycle stabilizer uses a delay-locked loop (DLL) to create the nonsampling edge. As a result, any changes to the sampling frequency require approximately eight clock cycles to allow the DLL to acquire and lock to the new rate.

## Clock Jitter Considerations

High speed, high resolution ADCs are sensitive to the quality of the clock input. The degradation in SNR at a given input frequency ( $f_A$ ) due only to aperture jitter ( $t_j$ ) can be calculated by

$$\text{SNR Degradation} = 20 \times \log [1/2 \times \pi \times f_A \times t_j]$$

In this equation, the rms aperture jitter represents the root mean square of all jitter sources, including the clock input, analog input signal, and ADC aperture jitter. IF undersampling applications are particularly sensitive to jitter (see Figure 59).

The clock input should be treated as an analog signal in cases where aperture jitter may affect the dynamic range of the AD9271. Power supplies for clock drivers should be separated from the ADC output driver supplies to avoid modulating the clock signal with digital noise. Low jitter, crystal-controlled oscillators make the best clock sources, such as the Valpey Fisher VFAC3 series. If the clock is generated from another type of source (by gating, dividing, or other methods), it should be retimed by the original clock during the last step.

Refer to the AN-501 Application Note and the AN-756 Application Note for more in-depth information about how jitter performance relates to ADCs (visit [www.analog.com](http://www.analog.com)).

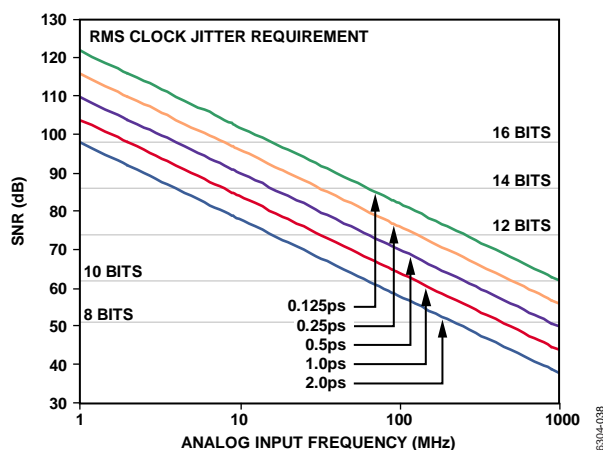

Figure 59. Ideal SNR vs. Input Frequency and Jitter

### Power Dissipation and Power-Down Mode

As shown in Figure 61, the power dissipated by the AD9271 is proportional to its sample rate. The digital power dissipation does not vary much because it is determined primarily by the DRVDD supply and bias current of the LVDS output drivers (Figure 60).

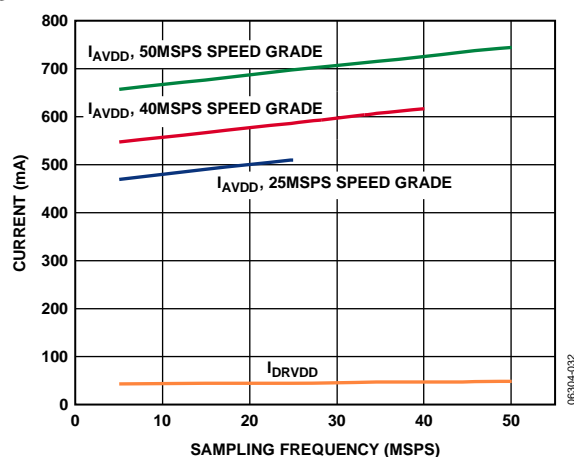

Figure 60. Supply Current vs.  $f_{SAMPLE}$  for  $f_{IN} = 7.5$  MHz

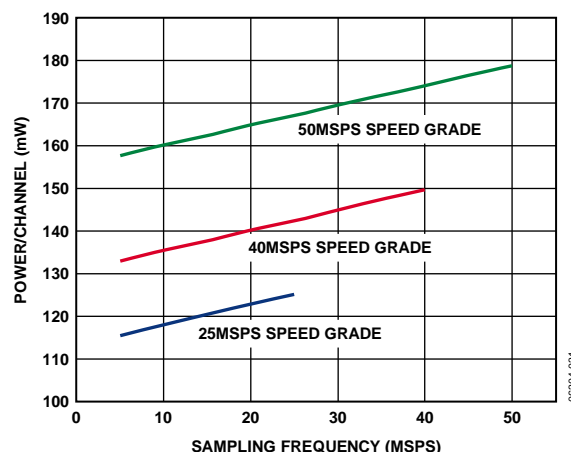

Figure 61. Power per Channel vs.  $f_{SAMPLE}$  for  $f_{IN} = 7.5$  MHz

By asserting the PDWN pin high, the AD9271 is placed into power-down mode. In this state, the device typically dissipates 2 mW. During power-down, the LVDS output drivers are placed into a high impedance state. The AD9271 returns to normal operating mode when the PDWN pin is pulled low. This pin is both 1.8 V and 3.3 V tolerant.

By asserting the STBY pin high, the AD9271 is placed into a standby mode. In this state, the device typically dissipates 65 mW. During standby, the entire part is powered down except the internal references. The LVDS output drivers are placed into a high impedance state. This mode is well suited for applications that require power savings because it allows the device to be powered down when not in use and then quickly powered up. The time to power the device back up is also greatly reduced. The AD9271 returns to normal operating mode when the STBY pin is pulled low. This pin is both 1.8 V and 3.3 V tolerant.

In power-down mode, low power dissipation is achieved by shutting down the reference, reference buffer, PLL, and biasing networks. The decoupling capacitors on REFT and REFB are discharged when entering power-down mode and must be recharged when returning to normal operation. As a result, the wake-up time is related to the time spent in the power-down mode: shorter cycles result in proportionally shorter wake-up times. To restore the device to full operation, approximately 1 ms is required when using the recommended 0.1  $\mu$ F and 4.7  $\mu$ F decoupling capacitors on the REFT and REFB pins and the 0.01  $\mu$ F decoupling capacitors on the GAIN $\pm$  pins. Most of this time is dependent on the gain decoupling; higher value decoupling capacitors on the GAIN $\pm$  pins result in longer wake-up times.

There are a number of other power-down options available when using the SPI port interface. The user can individually power down each channel or put the entire device into standby mode. This allows the user to keep the internal PLL powered up when fast wake-up times are required. The wake-up time is slightly dependent on gain. To achieve a 1  $\mu$ s wake-up time when the device is in standby mode, 0.5 V must be applied to the GAIN $\pm$  pins. See the Memory Map section for more details on using these features.

## Digital Outputs and Timing

The AD9271 differential outputs conform to the ANSI-644 LVDS standard on default power-up. This can be changed to a low power, reduced signal option similar to the IEEE 1596.3 standard by using the SDIO pin or via the SPI. This LVDS standard can further reduce the overall power dissipation of the device by approximately 36 mW. See the SDIO Pin section or Table 15 for more information.

The LVDS driver current is derived on chip and sets the output current at each output equal to a nominal 3.5 mA. A 100 Ω differential termination resistor placed at the LVDS receiver inputs results in a nominal 350 mV swing at the receiver.

The AD9271 LVDS outputs facilitate interfacing with LVDS receivers in custom ASICs and FPGAs that have LVDS capability for superior switching performance in noisy environments. Single point-to-point net topologies are recommended with a 100 Ω termination resistor placed as close to the receiver as possible. No far-end receiver termination and poor differential trace routing may result in timing errors. It is recommended that the trace length be no longer than 24 inches and that the differential output traces be kept close together and at equal lengths. An example of the FCO, DCO, and data stream with proper trace length and position can be found in Figure 62.

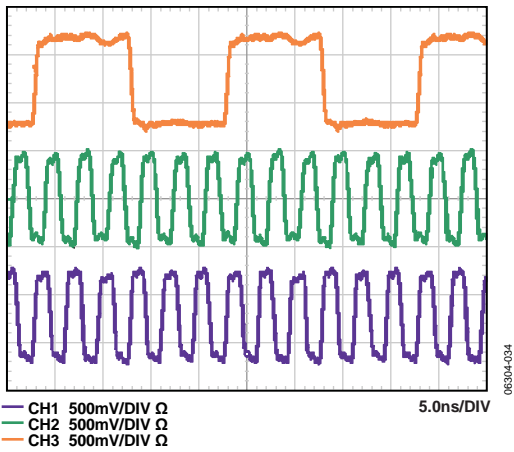

Figure 62. LVDS Output Timing Example in ANSI-644 Mode (Default)

An example of the LVDS output using the ANSI-644 standard (default) data eye and a time interval error (TIE) jitter histogram with trace lengths of less than 24 inches on regular FR-4 material is shown in Figure 63. Figure 64 shows an example of the trace lengths exceeding 24 inches on regular FR-4 material. Notice that the TIE jitter histogram reflects the decrease of the data eye opening as the edge deviates from the ideal position; therefore, the user must determine if the waveforms meet the timing budget of the design when the trace lengths exceed 24 inches.

Additional SPI options allow the user to further increase the internal termination (and therefore increase the current) of all eight outputs in order to drive longer trace lengths (see Figure 65). Even though this produces sharper rise and fall times on the data edges, is less prone to bit errors, and improves frequency distribution (see Figure 65), the power dissipation of the DRVDD supply increases when this option is used.

In cases that require increased driver strength to the DCO± and FCO± outputs because of load mismatch, Register 0x15 allows the user to double the drive strength. To do this, first set the appropriate bit in Register 0x05. Note that this feature cannot be used with Bit 4 and Bit 5 in Register 0x15 because these bits take precedence over this feature. See the Memory Map section for more details.

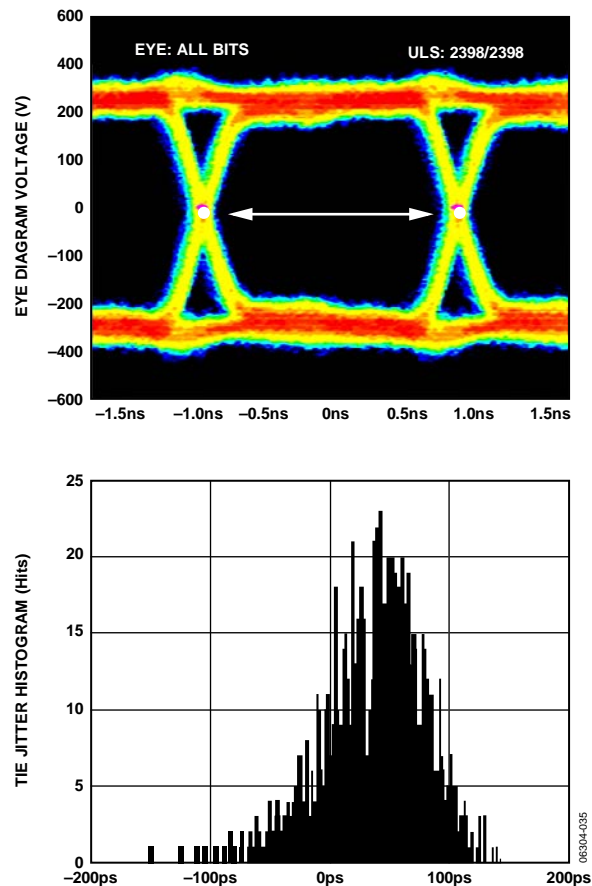

Figure 63. Data Eye for LVDS Outputs in ANSI-644 Mode with Trace Lengths of Less Than 24 Inches on Standard FR-4

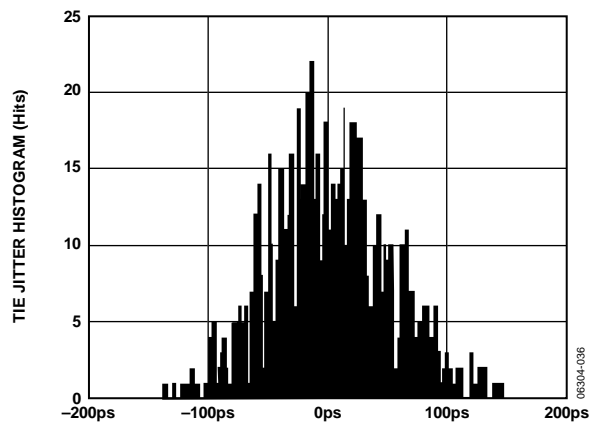
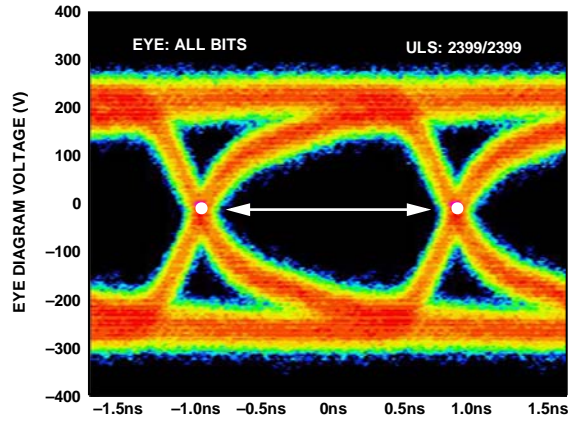

Figure 64. Data Eye for LVDS Outputs in ANSI-644 Mode with Trace Lengths of Greater Than 24 Inches on Standard FR-4

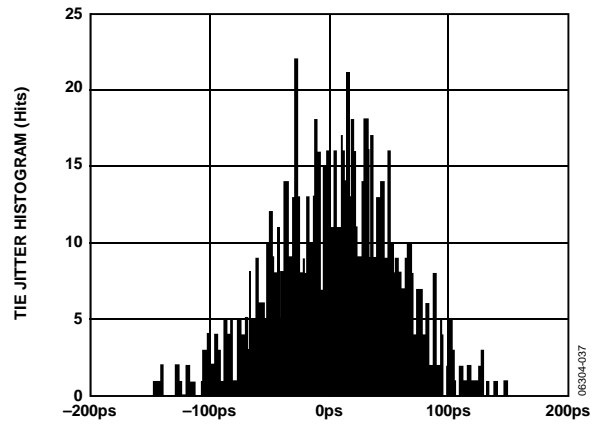
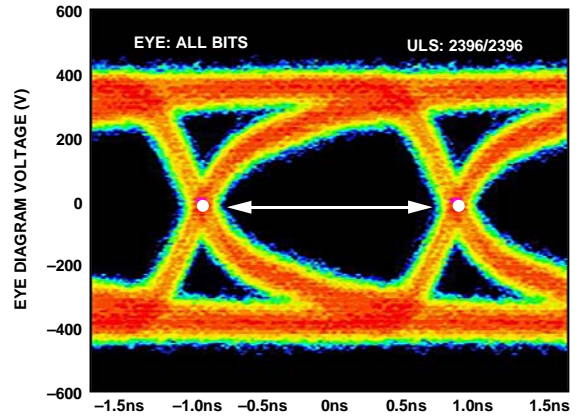

Figure 65. Data Eye for LVDS Outputs in ANSI-644 Mode with 100  $\Omega$  Termination On and Trace Lengths of Greater Than 24 Inches on Standard FR-4

# AD9271

The format of the output data is offset binary by default. An example of the output coding format can be found in Table 9. To change the output data format to twos complement, see the Memory Map section.

**Table 9. Digital Output Coding**

Code	(VIN+) – (VIN–), Input Span = 2V p-p (V)	Digital Output Offset Binary (D11 ... D0)
4095	+1.00	1111 1111 1111
2048	0.00	1000 0000 0000
2047	–0.000488	0111 1111 1111
0	–1.00	0000 0000 0000

Data from each ADC is serialized and provided on a separate channel. The data rate for each serial stream is equal to 12 bits

**Table 10. Flexible Output Test Modes**

Output Test Mode Bit Sequence	Pattern Name	Digital Output Word 1	Digital Output Word 2	Subject to Data Format Select
0000	Off (default)	N/A	N/A	N/A
0001	Midscale short	1000 0000 (8 bits) 10 0000 0000 (10 bits) 1000 0000 0000 (12 bits) 10 0000 0000 0000 (14 bits)	Same	Yes
0010	+Full-scale short	1111 1111 (8 bits) 11 1111 1111 (10 bits) 1111 1111 1111 (12 bits) 11 1111 1111 1111 (14 bits)	Same	Yes
0011	–Full-scale short	0000 0000 (8 bits) 00 0000 0000 (10 bits) 0000 0000 0000 (12 bits) 00 0000 0000 0000 (14 bits)	Same	Yes
0100	Checkerboard	1010 1010 (8 bits) 10 1010 1010 (10 bits) 1010 1010 1010 (12 bits) 10 1010 1010 1010 (14 bits)	0101 0101 (8 bits) 01 0101 0101 (10 bits) 0101 0101 0101 (12 bits) 01 0101 0101 0101 (14 bits)	No
0101	PN sequence long <sup>1</sup>	N/A	N/A	Yes
0110	PN sequence short <sup>1</sup>	N/A	N/A	Yes
0111	One-/zero-word toggle	1111 1111 (8 bits) 11 1111 1111 (10 bits) 1111 1111 1111 (12 bits) 11 1111 1111 1111 (14 bits)	0000 0000 (8 bits) 00 0000 0000 (10 bits) 0000 0000 0000 (12 bits) 00 0000 0000 0000 (14 bits)	No
1000	User input	Register 0x19 and Register 0x1A	Register 0x1B and Register 0x1C	No
1001	1-/0-bit toggle	1010 1010 (8 bits) 10 1010 1010 (10 bits) 1010 1010 1010 (12 bits) 10 1010 1010 1010 (14 bits)	N/A	No
1010	1x sync	0000 1111 (8 bits) 00 0001 1111 (10 bits) 0000 0011 1111 (12 bits) 00 0000 0111 1111 (14 bits)	N/A	No
1011	One bit high	1000 0000 (8 bits) 10 0000 0000 (10 bits) 1000 0000 0000 (12 bits) 10 0000 0000 0000 (14 bits)	N/A	No
1100	Mixed bit frequency	1010 0011 (8 bits) 10 0110 0011 (10 bits) 1010 0011 0011 (12 bits) 10 1000 0110 0111 (14 bits)	N/A	No

<sup>1</sup> All test mode options except PN sequence short and PN sequence long can support 8- to 14-bit word lengths in order to verify data capture to the receiver.

times the sample clock rate, with a maximum of 600 Mbps (12 bits × 50 MSPS = 600 Mbps). The lowest typical conversion rate is 10 MSPS, but the PLL can be set up for encode rates as low as 5 MSPS via the SPI if lower sample rates are required for a specific application. See the Memory Map section for details on enabling this feature.

Two output clocks are provided to assist in capturing data from the AD9271. DCO± is used to clock the output data and is equal to six times the sampling clock rate. Data is clocked out of the AD9271 and must be captured on the rising and falling edges of the DCO± that supports double data rate (DDR) capturing. The frame clock output (FCO±) is used to signal the start of a new output byte and is equal to the sampling clock rate. See the timing diagram shown in Figure 2 for more information.

When using the serial port interface (SPI), the  $DCO_{\pm}$  phase can be adjusted in  $60^{\circ}$  increments relative to the data edge. This enables the user to refine system timing margins if required. The default  $DCO_{\pm}$  timing, as shown in Figure 2, is  $90^{\circ}$  relative to the output data edge.

An 8-, 10-, and 14-bit serial stream can also be initiated from the SPI. This allows the user to implement different serial streams to test the device's compatibility with lower and higher resolution systems. When changing the resolution to an 8- or 10-bit serial stream, the data stream is shortened. When using the 14-bit option, the data stream stuffs two 0s at the end of the normal 14-bit serial data.

When using the SPI, all of the data outputs can also be inverted from their nominal state. This is not to be confused with inverting the serial stream to an LSB-first mode. In default mode, as shown in Figure 2, the MSB is represented first in the data output serial stream. However, this can be inverted so that the LSB is represented first in the data output serial stream (see Figure 3).

There are 12 digital output test pattern options available that can be initiated through the SPI. This feature is useful when validating receiver capture and timing. Refer to Table 10 for the output bit sequencing options available. Some test patterns have two serial sequential words and can be alternated in various ways, depending on the test pattern chosen. It should be noted that some patterns may not adhere to the data format select option. In addition, customer user patterns can be assigned in the 0x19, 0x1A, 0x1B, and 0x1C register addresses. All test mode options except PN sequence short and PN sequence long can support 8- to 14-bit word lengths in order to verify data capture to the receiver.

The PN sequence short pattern produces a pseudorandom bit sequence that repeats itself every  $2^9 - 1$  bits, or 511 bits. A description of the PN sequence and how it is generated can be found in Section 5.1 of the ITU-T 0.150 (05/96) standard. The only difference is that the starting value is a specific value instead of all 1s (see Table 11 for the initial values).

The PN sequence long pattern produces a pseudorandom bit sequence that repeats itself every  $2^{23} - 1$  bits, or 8,388,607 bits. A description of the PN sequence and how it is generated can be found in Section 5.6 of the ITU-T 0.150 (05/96) standard. The only differences are that the starting value is a specific value instead of all 1s and the AD9271 inverts the bit stream with relation to the ITU standard (see Table 11 for the initial values).

**Table 11. PN Sequence**

Sequence	Initial Value	First Three Output Samples (MSB First)
PN Sequence Short	0x0df	0xdf9, 0x353, 0x301
PN Sequence Long	0x29b80a	0x591, 0xfd7, 0xa3

Consult the Memory Map section for information on how to change these additional digital output timing features through the SPI.

### **SDIO Pin**

This pin is required to operate the SPI. It has an internal 30 k $\Omega$  pull-down resistor that pulls this pin low and is only 1.8 V tolerant. If applications require that this pin be driven from a 3.3 V logic level, insert a 1 k $\Omega$  resistor in series with this pin to limit the current.

### **SCLK Pin**

This pin is required to operate the SPI port interface. It has an internal 30 k $\Omega$  pull-down resistor that pulls this pin low and is both 1.8 V and 3.3 V tolerant.

### **CSB Pin**

This pin is required to operate the SPI port interface. It has an internal 70 k $\Omega$  pull-down resistor that pulls this pin low and is both 1.8 V and 3.3 V tolerant.

### **RBIAS Pin**

To set the internal core bias current of the ADC, place a resistor that is nominally equal to 10.0 k $\Omega$  between the RBIAS pin and ground. Using a resistor of another value degrades the performance of the device. Therefore, it is imperative that at least a 1% tolerance on this resistor be used to achieve consistent performance.

### **Voltage Reference**

A stable and accurate 0.5 V voltage reference is built into the AD9271. This is gained up internally by a factor of 2, setting VREF to 1.0 V, which results in a full-scale differential input span of 2.0 V p-p for the ADC. VREF is set internally by default, but the VREF pin can be driven externally with a 1.0 V reference to achieve more accuracy. However, full-scale ranges below 2.0 V p-p are not supported by this device.

When applying the decoupling capacitors to the VREF, REFT, and REFB pins, use ceramic low ESR capacitors. These capacitors should be close to reference pins and on the same layer of the PCB as the AD9271. The recommended capacitor values and configurations for the AD9271 reference pin can be found in Figure 66.

**Table 12. Reference Settings**

Selected Mode	SENSE Voltage	Resulting VREF (V)	Resulting Differential Span (V p-p)
External Reference	AVDD	N/A	$2 \times$ external reference
Internal, 2 V p-p FSR	AGND to 0.2 V	1.0	2.0

## Internal Reference Operation

A comparator within the AD9271 detects the potential at the SENSE pin and configures the reference. If SENSE is grounded, the reference amplifier switch is connected to the internal resistor divider (see Figure 66), setting VREF to 1 V.

The REFT and REFB pins establish their input span of the ADC core from the reference configuration. The analog input full-scale range of the ADC equals twice the voltage at the reference pin for either an internal or an external reference configuration.

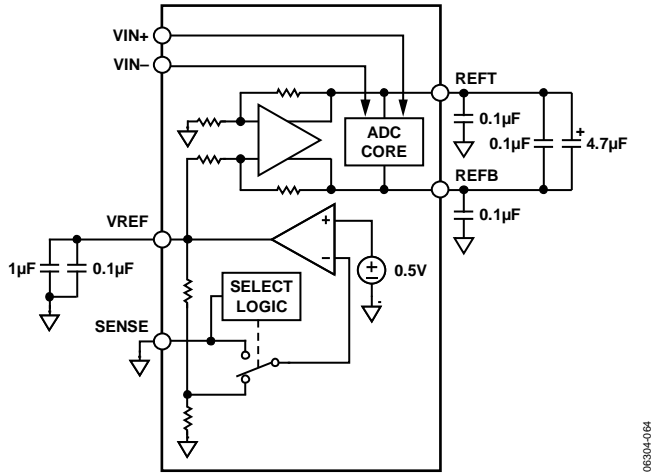
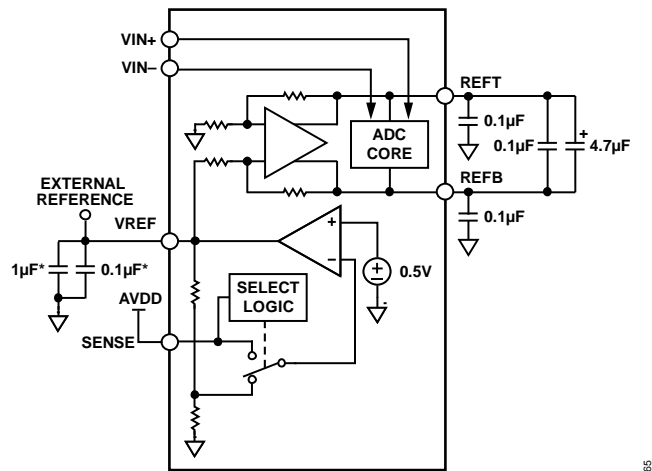

Figure 66. Internal Reference Configuration



\*OPTIONAL.

Figure 67. External Reference Operation

## External Reference Operation

The use of an external reference may be necessary to enhance the gain accuracy of the ADC or to improve thermal drift characteristics. Figure 69 shows the typical drift characteristics of the internal reference in 1 V mode.

When the SENSE pin is tied to AVDD, the internal reference is disabled, allowing the use of an external reference. The external reference is loaded with an equivalent 6 kΩ load. An internal reference buffer generates the positive and negative full-scale references, REFT and REFB, for the ADC core. Therefore, the external reference must be limited to a nominal voltage of 1.0 V.

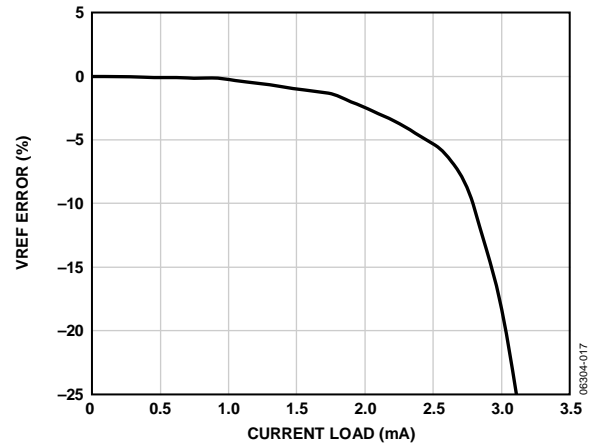

Figure 68. VREF Accuracy vs. Load, AD9271-50

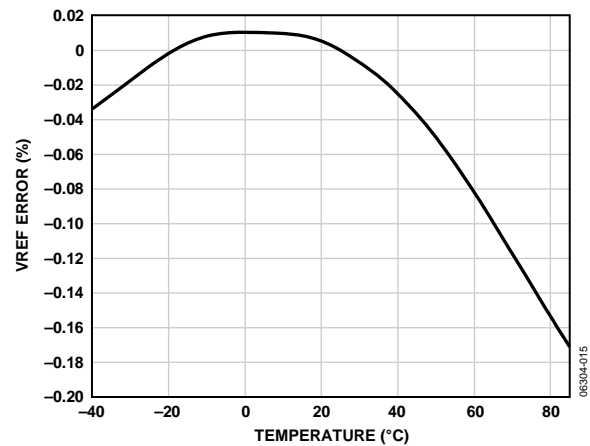

Figure 69. Typical VREF Drift, AD9271-50

## SERIAL PORT INTERFACE (SPI)

The AD9271 serial port interface allows the user to configure the signal chain for specific functions or operations through a structured register space provided inside the chip. This offers the user added flexibility and customization depending on the application. Addresses are accessed via the serial port and can be written to or read from via the port. Memory is organized into bytes that can be further divided into fields, as documented in the Memory Map section. Detailed operational information can be found in the Analog Devices, Inc., AN-877 Application Note, *Interfacing to High Speed ADCs via SPI*.

Three pins define the serial port interface, or SPI: the SCLK, SDIO, and CSB pins. The SCLK (serial clock) is used to synchronize the read and write data presented to the device. The SDIO (serial data input/output) is a dual-purpose pin that allows data to be sent to and read from the device's internal memory map registers. The CSB (chip select bar) is an active low control that enables or disables the read and write cycles (see Table 13).

**Table 13. Serial Port Pins**

Pin	Function
SCLK	Serial Clock. The serial shift clock input. SCLK is used to synchronize serial interface reads and writes.
SDIO	Serial Data Input/Output. A dual-purpose pin. The typical role for this pin is as an input or output, depending on the instruction sent and the relative position in the timing frame.
CSB	Chip Select Bar (Active Low). This control gates the read and write cycles.

The falling edge of the CSB in conjunction with the rising edge of the SCLK determines the start of the framing sequence. During an instruction phase, a 16-bit instruction is transmitted, followed by one or more data bytes, which is determined by Bit Field W0 and Bit Field W1. An example of the serial timing and its definitions can be found in Figure 71 and Table 14.

In normal operation, CSB is used to signal to the device that SPI commands are to be received and processed. When CSB is brought low, the device processes SCLK and SDIO to process instructions. Normally, CSB remains low until the communication cycle is complete. However, if connected to a slow device, CSB can be brought high between bytes, allowing older microcontrollers enough time to transfer data into shift registers. CSB can be stalled when transferring one, two, or three bytes of data. When W0 and W1 are set to 11, the device enters streaming mode and continues to process data, either reading or writing, until the CSB is taken high to end the communication cycle. This allows complete memory transfers without having to provide additional instructions. Regardless of the mode, if CSB is taken high in the middle of any byte transfer, the SPI state machine is reset and the device waits for a new instruction.

In addition to the operation modes, the SPI port can be configured to operate in different manners. For example, CSB can be tied low to enable 2-wire mode. When CSB is tied low, SCLK and SDIO are the only pins required for communication. Although the device is synchronized during power-up, caution must be exercised when using this mode to ensure that the serial port remains synchronized with the CSB line. When operating in 2-wire mode, it is recommended that a 1-, 2-, or 3-byte transfer be used exclusively. Without an active CSB line, streaming mode can be entered but not exited.

In addition to word length, the instruction phase determines if the serial frame is a read or write operation, allowing the serial port to be used to both program the chip and read the contents of the on-chip memory. If the instruction is a readback operation, performing a readback causes the serial data input/output (SDIO) pin to change direction from an input to an output at the appropriate point in the serial frame.

Data can be sent in MSB- or LSB-first mode. MSB-first mode is the default at power-up and can be changed by adjusting the configuration register. For more information about this and other features, see the AN-877 Application Note, *Interfacing to High Speed ADCs via SPI*.

## HARDWARE INTERFACE

The pins described in Table 13 constitute the physical interface between the user's programming device and the serial port of the AD9271. The SCLK and CSB pins function as inputs when using the SPI interface. The SDIO pin is bidirectional, functioning as an input during write phases and as an output during readback.

In cases where multiple SDIO pins share a common connection, care should be taken to ensure that proper  $V_{OH}$  levels are met. Figure 70 shows the number of SDIO pins that can be connected together, assuming the same load as the AD9271 and the resulting  $V_{OH}$  level.

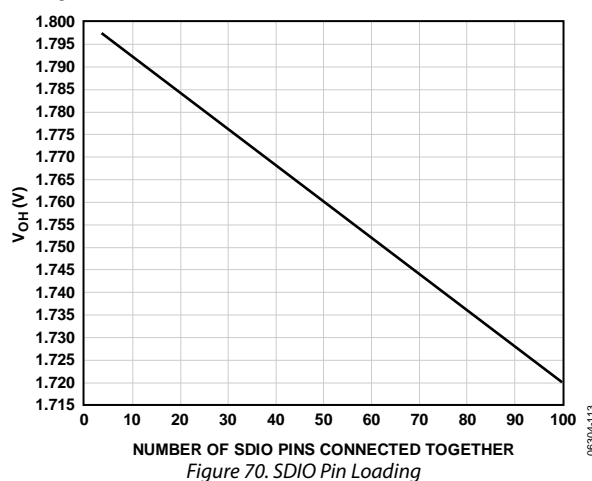

Figure 70. SDIO Pin Loading

# AD9271

This interface is flexible enough to be controlled by either serial PROMs or PIC microcontrollers. This provides the user an alternative method, other than a full SPI controller, to program the device (see the AN-812 Application Note).

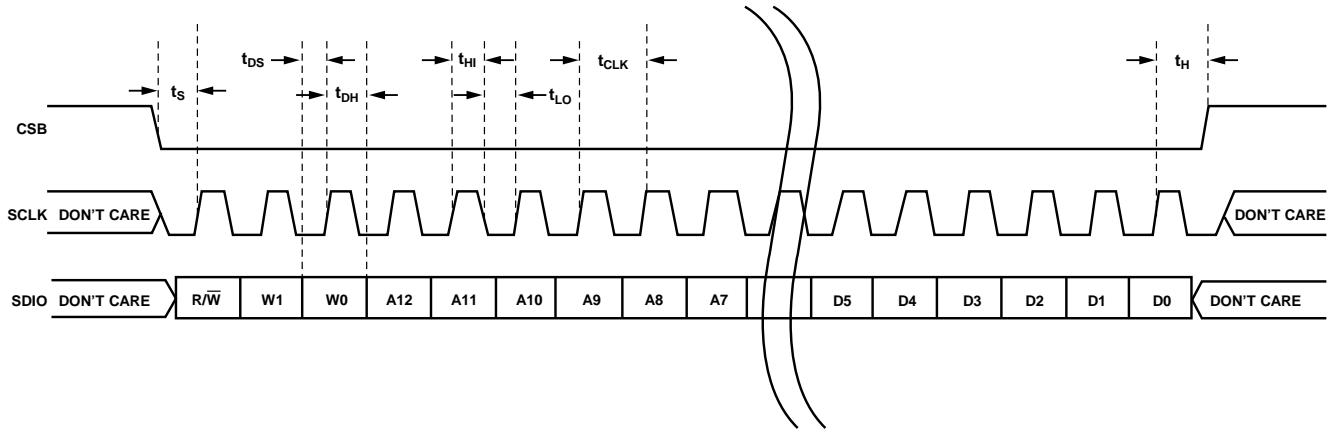

Figure 71. Serial Timing Details

010304-926

Table 14. Serial Timing Definitions

Parameter	Minimum Timing (ns)	Description
$t_{DS}$	5	Setup time between the data and the rising edge of SCLK
$t_{DH}$	2	Hold time between the data and the rising edge of SCLK
$t_{CLK}$	40	Period of the clock
$t_s$	5	Setup time between CSB and SCLK
$t_H$	2	Hold time between CSB and SCLK
$t_{HI}$	16	Minimum period that SCLK should be in a logic high state
$t_{LO}$	16	Minimum period that SCLK should be in a logic low state
$t_{EN\_SDIO}$	10	Minimum time for the SDIO pin to switch from an input to an output relative to the SCLK falling edge (not shown in Figure 71)
$t_{DIS\_SDIO}$	10	Minimum time for the SDIO pin to switch from an output to an input relative to the SCLK rising edge (not shown in Figure 71)

## MEMORY MAP

### READING THE MEMORY MAP TABLE

Each row in the memory map table has eight address locations. The memory map is roughly divided into three sections: the chip configuration register map (Address 0x00 to Address 0x02), the device index and transfer register map (Address 0x04, Address 0x05, and Address 0xFF), and the ADC functions register map (Address 0x08 to Address 0x2D).

The leftmost column of the memory map indicates the register address number; the default value is shown in the second rightmost column. The Bit 7 (MSB) column is the start of the default hexadecimal value given. For example, Address 0x09, the clock register, has a default value of 0x01, meaning that Bit 7 = 0, Bit 6 = 0, Bit 5 = 0, Bit 4 = 0, Bit 3 = 0, Bit 2 = 0, Bit 1 = 0, and Bit 0 = 1, or 0000 0001 in binary. This setting is the default for the duty cycle stabilizer in the on condition. By writing 0 to Bit 0 of this address followed by writing 0x01 in Register 0xFF (transfer bit), the duty cycle stabilizer turns off. It is important to follow each writing sequence with a transfer bit to update the SPI registers. All registers, except Register 0x00, Register 0x02,

Register 0x04, Register 0x05, and Register 0xFF, are buffered with a master-slave latch and require writing to the transfer bit. For more information on this and other functions, consult the AN-877 Application Note, *Interfacing to High Speed ADCs via SPI*.

### RESERVED LOCATIONS

Undefined memory locations should not be written to except when writing the default values suggested in this data sheet. Addresses that have values marked as 0 should be considered reserved and have 0 written into their registers during power-up.

### DEFAULT VALUES

After a reset, critical registers are automatically loaded with default values. These values are indicated in Table 15, where an X refers to an undefined feature.

### LOGIC LEVELS

An explanation of various registers follows: “Bit is set” is synonymous with “bit is set to Logic 1” or “writing Logic 1 for the bit.” Similarly, “clear a bit” is synonymous with “bit is set to Logic 0” or “writing Logic 0 for the bit.”

# AD9271

**Table 15. Memory Map Register<sup>1</sup>**

Addr. (Hex)	Register Name	Bit 7 (MSB)	Bit 6	Bit 5	Bit 4	Bit 3	Bit 2	Bit 1	Bit 0 (LSB)	Default Value	Notes/Comments
<b>Chip Configuration Registers</b>											
00	chip_port_config	0	LSB first 1 = on 0 = off (default)	Soft reset 1 = on 0 = off (default)	1	1	Soft reset 1 = on 0 = off (default)	LSB first 1 = on 0 = off (default)	0	0x18	The nibbles should be mirrored so that LSB- or MSB-first mode is set correctly regardless of shift mode.
01	chip_id	Chip ID Bits [7:0] (AD9271 = 0x13), (default)								Read only	Default is unique chip ID, different for each device. This is a read-only register.
02	chip_grade	X	X	Child ID [5:4] (identify device variants of Chip ID) 00 = 50 MSPS (default) 01 = 40 MSPS 10 = 25 MSPS		X	X	X	X	0x00	Child ID used to differentiate graded devices.
<b>Device Index and Transfer Registers</b>											
04	device_index_2	X	X	X	X	Data Channel H 1 = on (default) 0 = off	Data Channel G 1 = on (default) 0 = off	Data Channel F 1 = on (default) 0 = off	Data Channel E 1 = on (default) 0 = off	0x0F	Bits are set to determine which on-chip device receives the next write command.
05	device_index_1	X	X	Clock Channel DCO± 1 = on 0 = off (default)	Clock Channel FCO± 1 = on 0 = off (default)	Data Channel D 1 = on (default) 0 = off	Data Channel C 1 = on (default) 0 = off	Data Channel B 1 = on (default) 0 = off	Data Channel A 1 = on (default) 0 = off	0x0F	Bits are set to determine which on-chip device receives the next write command.
FF	device_update	X	X	X	X	X	X	X	SW transfer 1 = on 0 = off (default)	0x00	Synchronously transfers data from the master shift register to the slave.
<b>ADC Functions Registers</b>											
08	modes	X	X	X	X	LNA bypass 1 = on 0 = off (default)	Internal power-down mode 000 = chip run (default) 001 = full power-down 010 = standby 011 = reset 100 = CW mode (TGC PDWN)			0x00	Determines various generic modes of chip operation.
09	clock	X	X	X	X	X	X	X	Duty cycle stabilizer 1 = on (default) 0 = off	0x01	Turns the internal duty cycle stabilizer on and off.

Addr. (Hex)	Register Name	Bit 7 (MSB)	Bit 6	Bit 5	Bit 4	Bit 3	Bit 2	Bit 1	Bit 0 (LSB)	Default Value	Notes/Comments
0D	test_io	User test mode 00 = off (default) 01 = on, single alternate 10 = on, single once 11 = on, alternate once		Reset PN long gen 1 = on 0 = off (default)	Reset PN short gen 1 = on 0 = off (default)	Output test mode—see Table 10 0000 = off (default) 0001 = midscale short 0010 = +FS short 0011 = -FS short 0100 = checkerboard output 0101 = PN sequence long 0110 = PN sequence short 0111 = one-/zero-word toggle 1000 = user input 1001 = 1-/0-bit toggle 1010 = 1× sync 1011 = one bit high 1100 = mixed bit frequency (format determined by output_mode)				0x00	When this register is set, the test data is placed on the output pins in place of normal data. (Local, expect for PN sequence.)
0F	flex_channel_input	Filter cutoff frequency control 0000 = $1.3 \times 1/3 \times f_{\text{SAMPLE}}$ 0001 = $1.2 \times 1/3 \times f_{\text{SAMPLE}}$ 0010 = $1.1 \times 1/3 \times f_{\text{SAMPLE}}$ 0011 = $1.0 \times 1/3 \times f_{\text{SAMPLE}}$ 0100 = $0.9 \times 1/3 \times f_{\text{SAMPLE}}$ 0101 = $0.8 \times 1/3 \times f_{\text{SAMPLE}}$ 0110 = $0.7 \times 1/3 \times f_{\text{SAMPLE}}$				X	X	X	X	0x30	Antialiasing filter cutoff (global).
10	flex_offset	X	X	6-bit LNA offset adjustment 011001 = 50 MSPS speed grade 011010 = 40 MSPS speed grade 011111 = 25 MSPS speed grade					0x20	LNA force offset correction (local).	
11	flex_gain	X	X	X	X	X	X	LNA gain 00 = 5× 01 = 6× 10 = 8×	0x01	LNA gain adjustment (global).	
14	output_mode	X	0 = LVDS ANSI-644 (default) 1 = LVDS low power, (IEEE 1596.3 similar)	X	X	X	Output invert 1 = on 0 = off (default)	00 = offset binary (default) 01 = twos complement	0x00	Configures the outputs and the format of the data.	
15	output_adjust	X	X	Output driver termination 00 = none (default) 01 = 200 Ω 10 = 100 Ω 11 = 100 Ω		X	X	X	DCO± and FCO± 2× drive strength 1 = on 0 = off (default)	0x00	Determines LVDS or other output properties. Primarily functions to set the LVDS span and common-mode levels in place of an external resistor.
16	output_phase	X	X	X	X	0011 = output clock phase adjust (0000 through 1010) (Default: 180° relative to data edge) 0000 = 0° relative to data edge 0001 = 60° relative to data edge 0010 = 120° relative to data edge 0011 = 180° relative to data edge 0100 = 240° relative to data edge 0101 = 300° relative to data edge 0110 = 360° relative to data edge 0111 = 420° relative to data edge 1000 = 480° relative to data edge 1001 = 540° relative to data edge 1010 = 600° relative to data edge 1011 to 1111 = 660° relative to data edge			0x03	On devices that utilize global clock divide, determines which phase of the divider output is used to supply the output clock. Internal latching is unaffected.	

# AD9271

Addr. (Hex)	Register Name	Bit 7 (MSB)	Bit 6	Bit 5	Bit 4	Bit 3	Bit 2	Bit 1	Bit 0 (LSB)	Default Value	Notes/Comments
19	user_patt1_lsb	B7	B6	B5	B4	B3	B2	B1	B0	0x00	User-defined pattern, 1 LSB (global).
1A	user_patt1_msb	B15	B14	B13	B12	B11	B10	B9	B8	0x00	User-defined pattern, 1 MSB (global).
1B	user_patt2_lsb	B7	B6	B5	B4	B3	B2	B1	B0	0x00	User-defined pattern, 2 LSB (global).
1C	user_patt2_msb	B15	B14	B13	B12	B11	B10	B9	B8	0x00	User-defined pattern, 2 MSB (global).
21	serial_control	LSB first 1 = on 0 = off (default)	X	X	X	<10 MSPS, low encode rate mode 1 = on 0 = off (default)	000 = 12 bits (default, normal bit stream) 001 = 8 bits 010 = 10 bits 011 = 12 bits 100 = 14 bits			0x00	Serial stream control. Default causes MSB first and the native bit stream (global).
22	serial_ch_stat	X	X	X	X	X	X	Channel output reset 1 = on 0 = off (default)	Channel power-down 1 = on 0 = off (default)	0x00	Used to power down individual sections of a converter (local).
2B	flex_filter	X	Enable automatic low-pass tuning 1 = on 0 = off (default)	X	X	X	X	High-pass filter cutoff 00 = dc (default) 01 = 700 kHz 10 = 350 kHz		0x00	Filter cutoff (global).
2C	analog_input	X	X	X	X	X	X	X	LOSW-x 1 = on 0 = off (default)	0x00	LNA active termination/ input impedance (global).
2D	cross_point_switch	X	X	X	Crosspoint switch enable 0 0000 = CWD0± (differential) 0 0001 = CWD1± (differential) 0 0010 = CWD2± (differential) 0 0011 = CWD3± (differential) 0 0100 = CWD4± (differential) 0 0101 = CWD5± (differential) 0 0111 = power down CW channel 1 0000 = CWD0+ (single ended) 1 0001 = CWD1+ (single ended) 1 0010 = CWD2+ (single ended) 1 0011 = CWD3+ (single ended) 1 0100 = CWD4+ (single ended) 1 0101 = CWD5+ (single ended) 1 0111 = power down CW channel 1 1000 = CWD0- (single ended) 1 1001 = CWD1- (single ended) 1 1010 = CWD2- (single ended) 1 1011 = CWD3- (single ended) 1 1100 = CWD4- (single ended) 1 1101 = CWD5- (single ended) 1 1111 = power down CW channel					0x07	Crosspoint switch enable (local).

<sup>1</sup> X = an undefined feature

## APPLICATIONS INFORMATION

### DESIGN GUIDELINES

Before starting design and layout of the AD9271 as a system, it is recommended that the designer become familiar with these guidelines, which discuss the special circuit connections and layout requirements needed for certain pins.

#### Power and Ground Recommendations

When connecting power to the AD9271, it is recommended that two separate 1.8 V supplies be used: one for analog (AVDD) and one for digital (DRVDD). The AD9271 also requires a 3.3 V supply (CWVDD) for the crosspoint section. If only one 1.8 V supply is available, it should be routed to the AVDD first and then tapped off and isolated with a ferrite bead or a filter choke preceded by decoupling capacitors for the DRVDD. The user should employ several decoupling capacitors on all supplies to cover both high and low frequencies. These capacitors should be located close to the point of entry at the PC board level and close to the parts with minimal trace lengths.

A single PC board ground plane should be sufficient when using the AD9271. With proper decoupling and smart partitioning of the PC board's analog, digital, and clock sections, optimum performance can be easily achieved.

#### Exposed Paddle Thermal Heat Slug Recommendations

It is required that the exposed paddle on the underside of the device be connected to the analog ground (AGND) to achieve the best electrical and thermal performance of the AD9271. An exposed continuous copper plane on the PCB should mate to the AD9271 exposed paddle, Pin 0. The copper plane should have several vias to achieve the lowest possible resistive thermal path for heat dissipation to flow through the bottom of the PCB. These vias should be filled or plugged with nonconductive epoxy.

To maximize the coverage and adhesion between the device and PCB, partition the continuous copper pad by overlaying a silkscreen or solder mask to divide it into several uniform sections. This ensures several tie points between the two during the reflow process. Using one continuous plane with no partitions guarantees only one tie point between the AD9271 and PCB. See Figure 72 for a PCB layout example. For more detailed information on packaging and for more PCB layout examples, see the AN-772 Application Note.

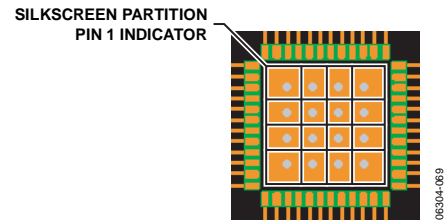

Figure 72. Typical PCB Layout

## EVALUATION BOARD

The AD9271 evaluation board provides all the support circuitry required to operate the AD9271 in its various modes and configurations. The LNA is driven differentially through a transformer. Figure 73 shows the typical bench characterization setup used to evaluate the ac performance of the AD9271. It is critical that the signal sources used for the analog input and clock have very low phase noise (<1 ps rms jitter) to realize the optimum performance of the signal chain. Proper filtering of the analog input signal to remove harmonics and lower the integrated or broadband noise at the input is also necessary to achieve the specified noise performance.

See the Quick Start Procedure section to get started and Figure 75 to Figure 86 for the complete schematics and layout diagrams that demonstrate the routing and grounding techniques that should be applied at the system level.

### POWER SUPPLIES

This evaluation board comes with a wall-mountable switching power supply that provides a 6 V, 2 A maximum output. Connect the supply to the rated 100 V ac to 240 V ac wall outlet at 47 Hz to 63 Hz. The other end is a 2.1 mm inner diameter jack that connects to the PCB at P701. Once on the PC board, the 6 V supply is fused and conditioned before connecting to three low dropout linear regulators that supply the proper bias to each of the various sections on the board.

When operating the evaluation board in a nondefault condition, L702 to L704 can be removed to disconnect the switching power supply. This enables the user to bias each section of the board individually. Use P501 to connect a different supply for each section. At least one 1.8 V supply is needed with a 1 A current capability for AVDD\_DUT and DRVDD\_DUT; however, it is recommended that separate supplies be used for both analog and digital domains. To operate the evaluation board using the

SPI and alternate clock options, a separate 3.3 V analog supply is needed in addition to the other supplies. The 3.3 V supply, or AVDD\_3.3 V, should have a 1 A current capability.

To bias the crosspoint switch circuitry or CW section, separate +5 V and -5 V supplies are required at P511. These should each have 1 A current capability. This section cannot be biased from a 6 V, 2 A wall supply. Separate supplies are required at P511.

### INPUT SIGNALS

When connecting the clock and analog source, use clean signal generators with low phase noise, such as Rohde & Schwarz SMA or HP8644B signal generators or the equivalent. Use a 1 m, shielded, RG-58, 50  $\Omega$  coaxial cable for making connections to the evaluation board. Enter the desired frequency and amplitude from the specifications tables. The evaluation board is set up to be clocked from the crystal oscillator, OSC401. If a different or external clock source is desired, follow the instructions for CLOCK outlined in the Default Operation and Jumper Selection Settings section. Typically, most Analog Devices evaluation boards can accept ~2.8 V p-p or 13 dBm sine wave input for the clock. When connecting the analog input source, it is recommended to use a multipole, narrow-band, band-pass filter with 50  $\Omega$  terminations. Analog Devices uses TTE and K&L Microwave, Inc., band-pass filters. The filter should be connected directly to the evaluation board.

### OUTPUT SIGNALS

The default setup uses the FIFO5 high speed, dual-channel FIFO data capture board (HSC-ADC-EVALCZ). Two of the eight channels can then be evaluated at the same time. For more information on channel settings on these boards and their optional settings, visit [www.analog.com/FIFO](http://www.analog.com/FIFO).

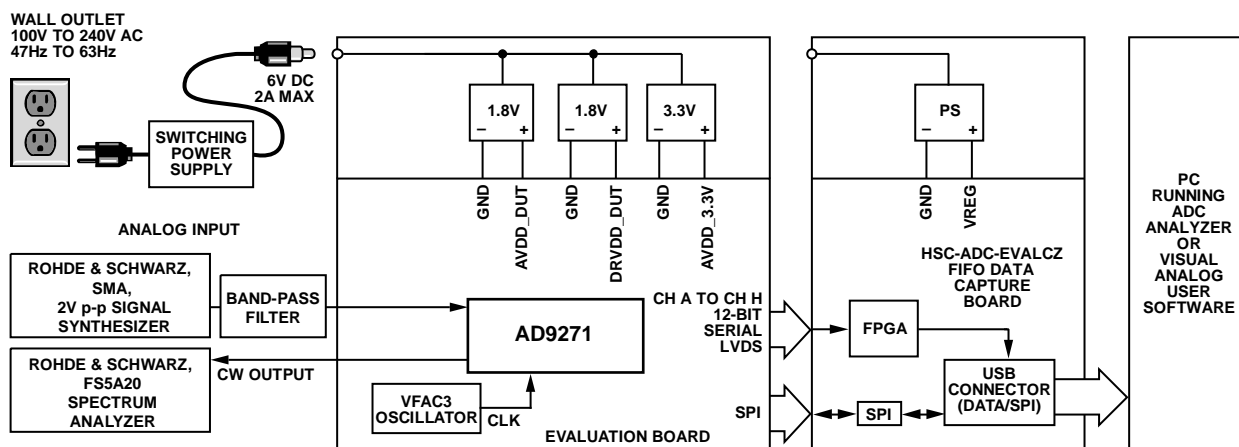

Figure 73. Evaluation Board Connection

## DEFAULT OPERATION AND JUMPER SELECTION SETTINGS

The following is a list of the default and optional settings or modes allowed on the AD9271 Rev. B evaluation board.

- **Power:** Connect the switching power supply that is supplied in the evaluation kit between a rated 100 V ac to 240 V ac wall outlet at 47 Hz to 63 Hz and P701.
- **AIN:** The evaluation board is set up for a transformer-coupled analog input with an optimum 50  $\Omega$  impedance match of 18 MHz of bandwidth. For a different bandwidth response, use the antialiasing filter settings.
- **VREF:** VREF is set to 1.0 V by tying the SENSE pin to ground, R317. This causes the ADC to operate in 2.0 V p-p full-scale range. A separate external reference option using the ADR510 or ADR520 is also included on the evaluation board. Populate R311 and R315 with 0  $\Omega$  resistors and remove C307. Proper use of the VREF options is noted in the Voltage Reference section. Note that ADC full-scale ranges less than 2.0 V p-p are not supported by this device.
- **RBIAS:** RBIAS has a default setting of 10 k $\Omega$  (R301) to ground and is used to set the ADC core bias current. However, note that using other than a 10 k $\Omega$  resistor for RBIAS may degrade the performance of the device, depending on the resistor chosen.
- **Clock:** The default clock input circuitry is derived from a simple transformer-coupled circuit using a high bandwidth 1:1 impedance ratio transformer (T401) that adds a very low amount of jitter to the clock path. The clock input is 50  $\Omega$  terminated and ac-coupled to handle single-ended sine wave types of inputs. The transformer converts the single-ended input to a differential signal that is clipped before entering the ADC clock inputs.

The evaluation board is already set up to be clocked from the crystal oscillator, OSC401. This oscillator is a low phase noise oscillator from Valpey Fisher (VFAC3-BHL-50MHz). If a different clock source is desired, remove R403, set Jumper J401 to disable the oscillator from running, and connect the external clock source to the SMA connector, P401.

A differential LVPECL clock driver can also be used to clock the ADC input using the AD9515 (U401). Populate R406 and R407 with 0  $\Omega$  resistors and remove R415 and R416 to disconnect the default clock path inputs. In addition, populate C405 and C406 with a 0.1  $\mu$ F capacitor and remove C409 and C410 to disconnect the default clock path outputs. The AD9515 has many pin-strappable options that are set to a default mode of operation. Consult the AD9515 data sheet for more information about these and other options.

- **PDWN:** To enable the power-down feature, short P303 to the on position (AVDD) on the PDWN pin.
- **STBY:** To enable the standby feature, short P302 to the on position (AVDD) on the STBY pin.
- **GAIN+, GAIN-:** To change the VGA attenuation, drive the GAIN+ pin from 0 V to 1 V on J301. This changes the VGA gain from 0 dB to 30 dB. This feature can also be driven from the R335 and R336 on-board resistive divider by installing a 0  $\Omega$  resistor in R337.
- **Non-SPI Mode:** For users who wish to operate the DUT without using the SPI, remove the jumpers on J501. This disconnects the CSB, SCLK, and SDIO pins from the control bus, allowing the DUT to operate in its simplest mode. Each of these pins has internal termination and will float to its respective level. Note that the device will only work in its default condition.
- **CWD+, CWD-:** To view the CWD2+/CWD2- and CWD3+/CWD3- outputs, jumper together the appropriate outputs on P403. All outputs are summed together on IOP and ION buses, fed to a 1:4 impedance ratio transformer, and buffered so that the user can view the output on a spectrum analyzer. This can be configured to be viewed in single-ended mode (default) or in differential mode. To set the voltage for the appropriate number of channels to be summed, change the value of R447 and R448 on the primary transformer (T402).

Upon shipment, the CWD0+/CWD0-, CWD1+/CWD1-, CWD4+/CWD4-, and CWD5+/CWD5- outputs are properly biased and ready to use with the AD8339 quad I/Q demodulator and phase shifter. The AD9271 evaluation board simply snaps into place on the AD8339 evaluation board (AD8339-EVALZ). Remove the jumpers connected to P3A and P4A on the AD8339 evaluation board, and snap the standoffs labeled MH502, MH504, and MH505 that are provided with the AD9271 into the AD8339 evaluation board standoff holes in the center of the board. The standoffs automatically lock into place and create a direct connection between the AD9271 CWDx $\pm$  outputs and the AD8339 inputs.

- **DOUTx+, DOUTx-:** If an alternative data capture method to the setup described in Figure 80 is used, optional receiver terminations, R601 to R610, can be installed next to the high speed backplane connector.

## QUICK START PROCEDURE

The following is a list of the default and optional settings when using the AD9271 either on the evaluation board or at the system level design.

If an evaluation board is not being used, follow only the SPI controller steps.

When using the AD9271 evaluation board,

1. Open ADC Analyzer on a PC, click **Configuration**, and select the appropriate product configuration file.  
If the correct product configuration file is not available, choose a similar product configuration file or click **Cancel** and create a new one. See the *ADC Analyzer User Manual* located at [www.analog.com/FIFO](http://www.analog.com/FIFO).
2. From the **Config** menu, choose **Channel Select**. To evaluate Channel A on the ADC evaluation board, ensure that only the Channel B checkbox in ADC Analyzer is selected.  
Channel A through Channel D correspond to Channel B in ADC Analyzer.  
Channel E through Channel H correspond to Channel A in ADC Analyzer.
3. Click **SPI** in ADC Analyzer to open the SPI controller software. If prompted for a configuration file, select the appropriate one. If not, look at the title bar of the window to see which configuration is loaded. If necessary, choose **Cfg Open** from the **File** menu and select the appropriate one. Note that the **CHIP ID(1)** field may be filled in regardless of whether the correct SPI controller configuration file is loaded.

When using the AD9271 evaluation board or system level design,

1. Click **New DUT** () in the SPI Controller software.
2. In the **Global** tab of SPI Controller, find the **CHIP GRADE(2)** box and use the drop-down menu to select the correct speed grade.
3. In the **ADCGlobal 0** tab of SPI Controller, find the **HIGHPASS(2B)** box and select the **Manual Tune** box to calibrate the antialiasing filter.

4. In SPI Controller, select **Controller Dialog** from the **Config** menu. In the **PROGRAM CONTROL** box, ensure that **Enable Auto Channel Update** is selected and click **OK**.
5. In the **Global** tab of SPI Controller, find the **DEVICE INDEX(4/5)** box. In the **ADC** column, click **S** so that the adjustment in the next step applies to all channels.
6. In the **ADC A** tab of SPI Controller, find the **OFFSET(10)** box and use the drop-down menu labeled **Offset Adj** to select the correct LNA offset correction: 25 decimal for the 50 MSPS speed grade, 26 decimal for the 40 MSPS speed grade, or 31 decimal for the 25 MSPS speed grade.
7. Click **FFT** () in Visual Analog.

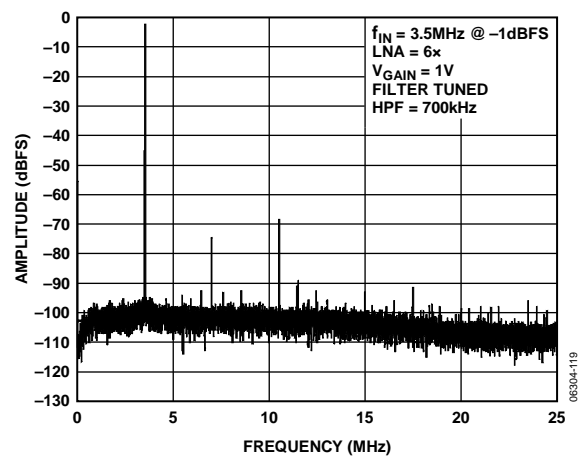

Figure 74. Typical FFT, AD9271-50

8. Adjust the amplitude of the input signal so that the fundamental is at the desired level. (Examine the **Fund:** reading in the left panel of the **ADC Analyzer FFT** window.) If the **GAIN±** pins voltage is low (near 0 V), it may not be possible to reach full scale without distortion. Use a higher gain setting or a lower input level to avoid distortion.
9. Right-click the FFT plot and select **Comments**. Use this box to record information such as the serial number of the board, the channel, the input and clock frequencies, the **GAIN±** pins voltage, and the date. Press the **PRINT SCREEN** key and save the FFT screenshot if desired.

SCHEMATICS AND ARTWORK

980-P0690

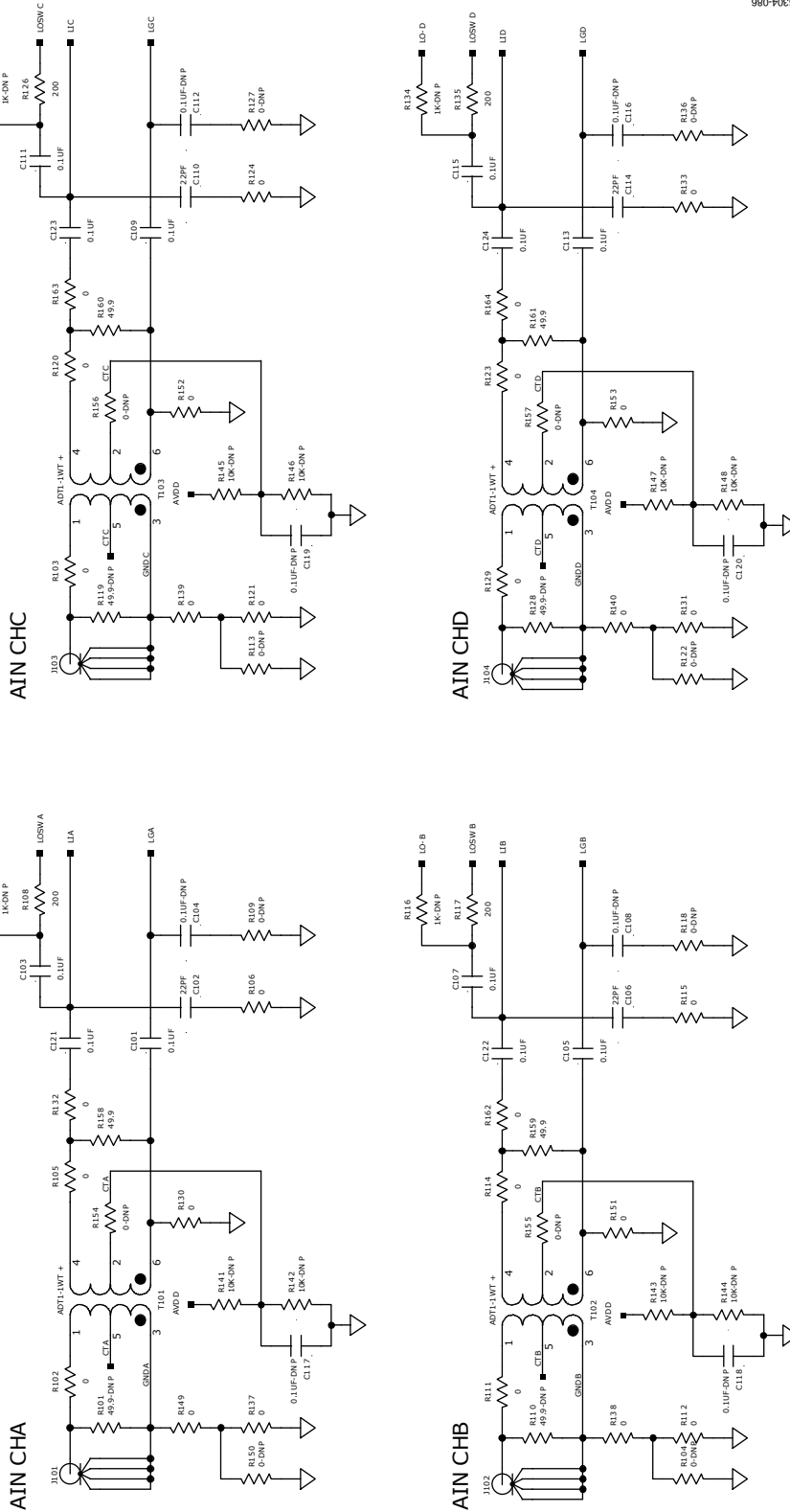

Figure 75. Evaluation Board Schematic, DUT Analog Input Circuits







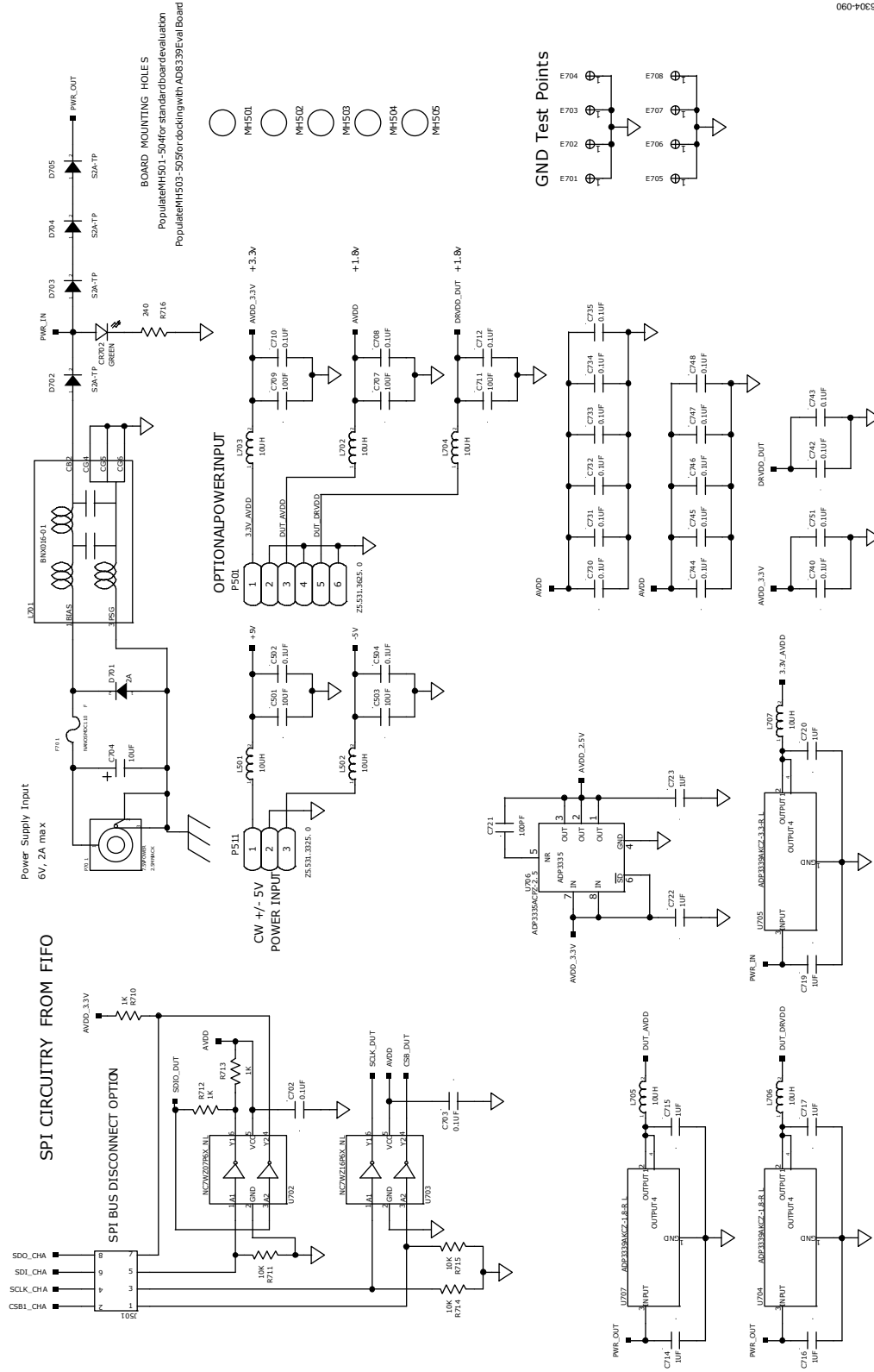

Figure 79. Evaluation Board Schematic, Power Supply and SPI Interface Circuitry

# Digital Outputs

FIFO5: DATA BUS 1 CONNECTOR

FIFO5: HS - SERIAL/SPI/AUX CONNECTOR

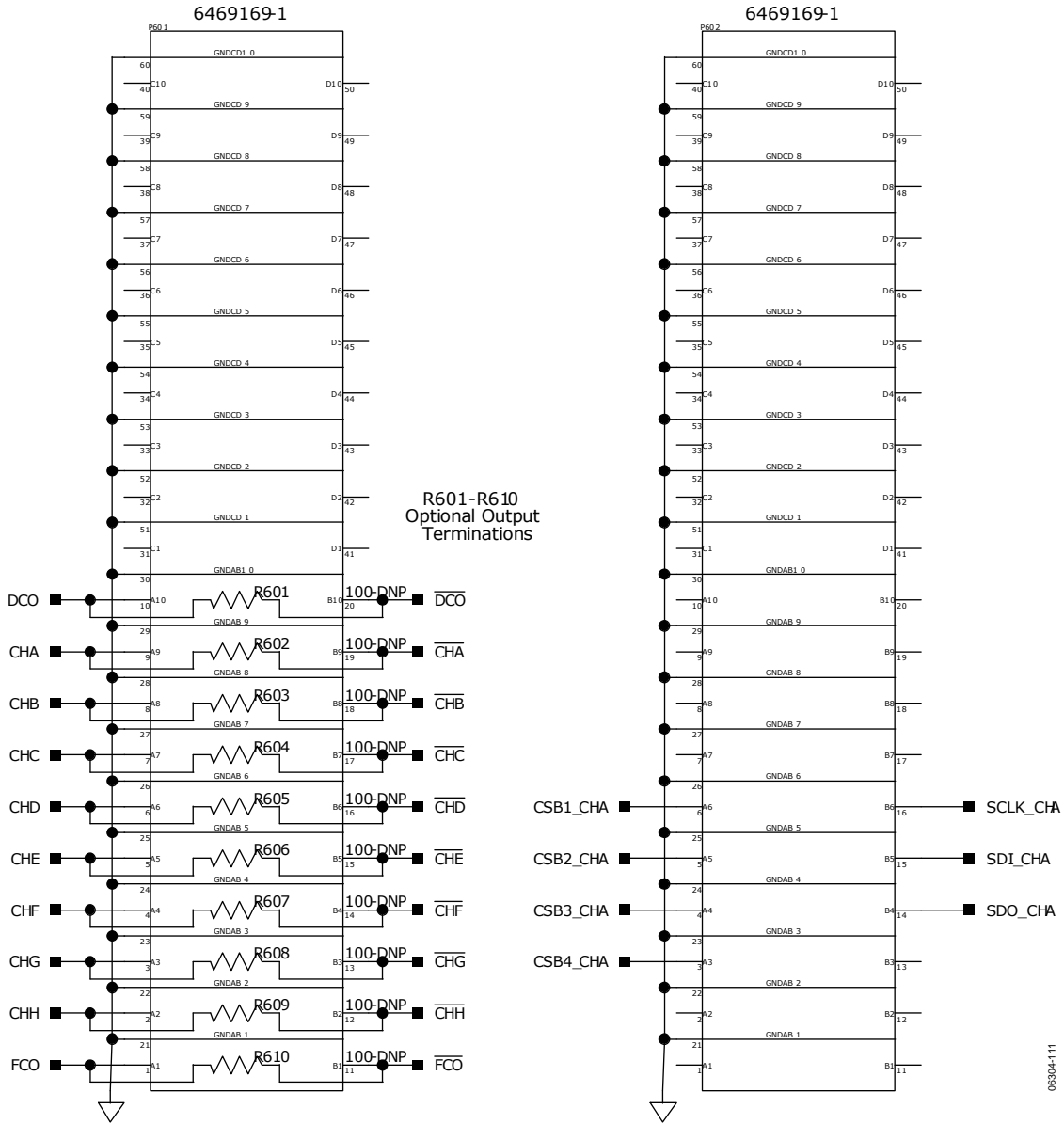

Figure 80. Evaluation Board Schematic, Digital Output Interface

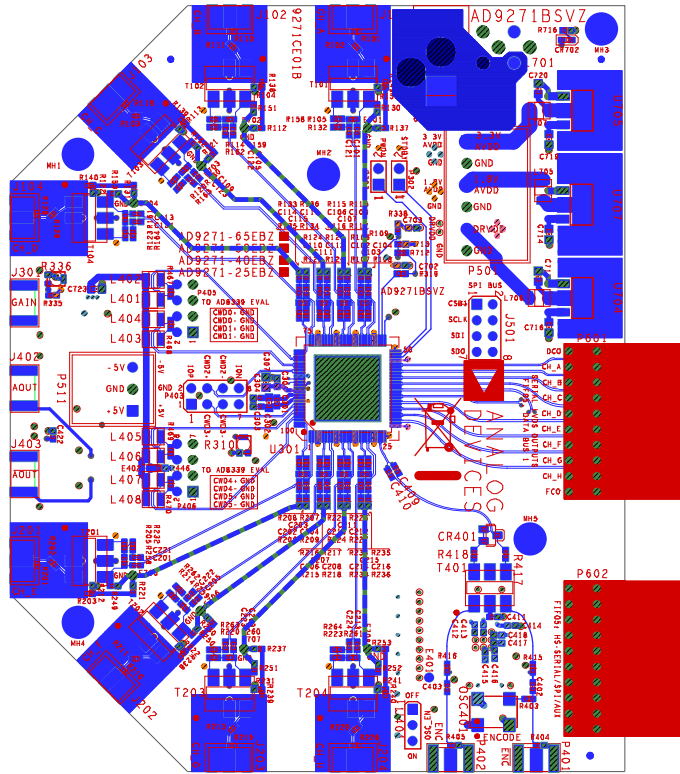

Figure 81. Evaluation Board Layout, Top Side

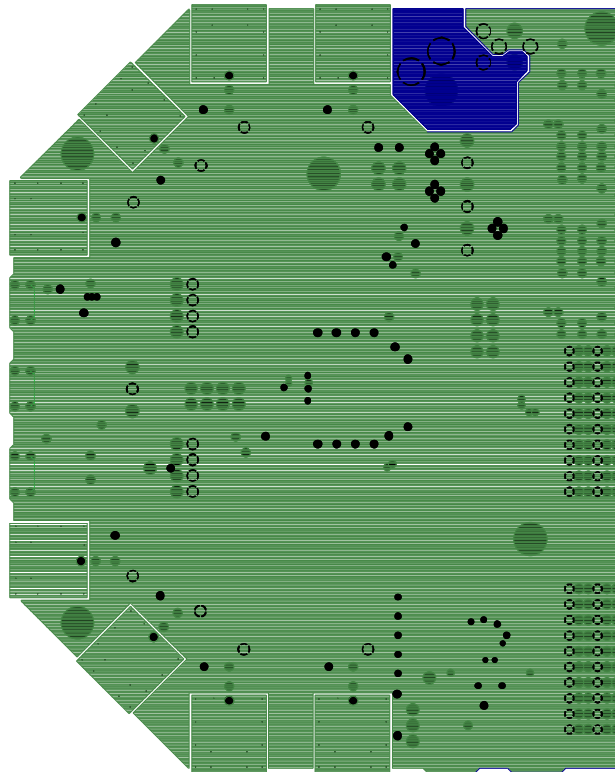

Figure 82. Evaluation Board Layout, Ground Plane (Layer 2)

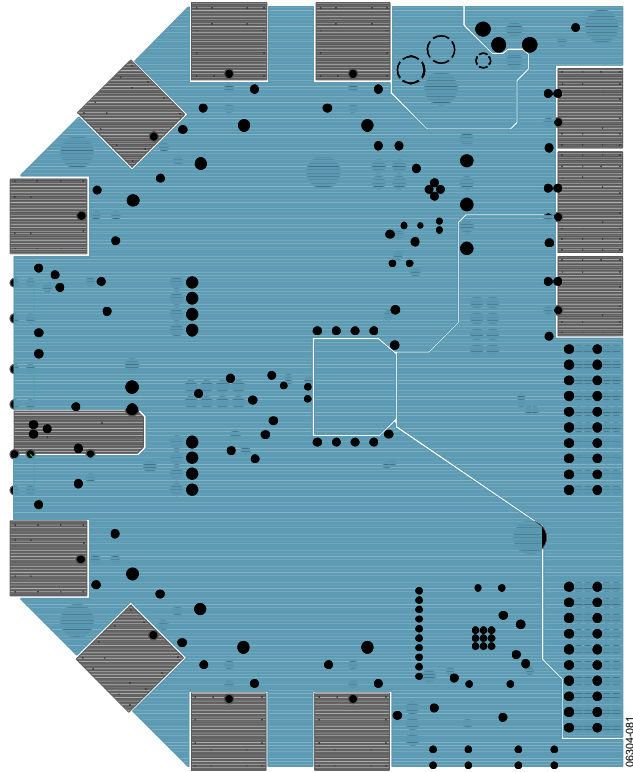

Figure 83. Evaluation Board Layout, Power Plane (Layer 3)

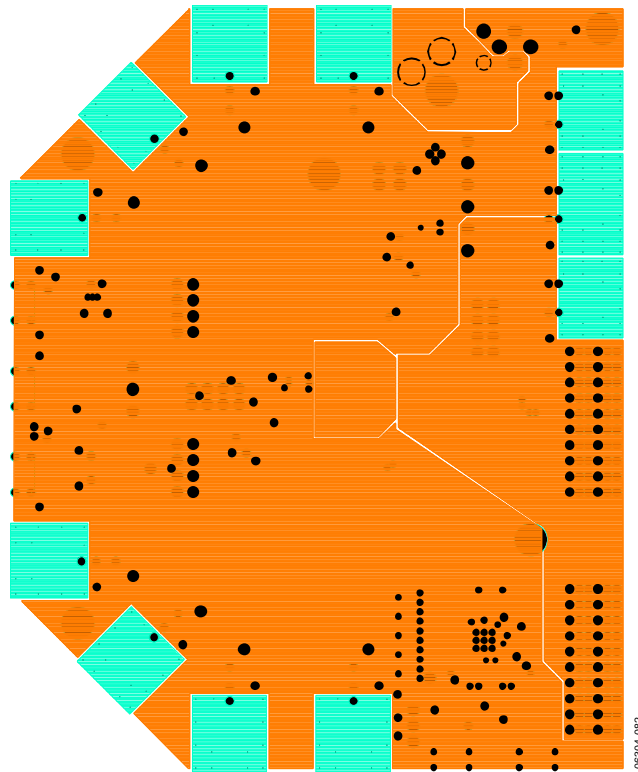

Figure 84. Evaluation Board Layout, Power Plane (Layer 4)

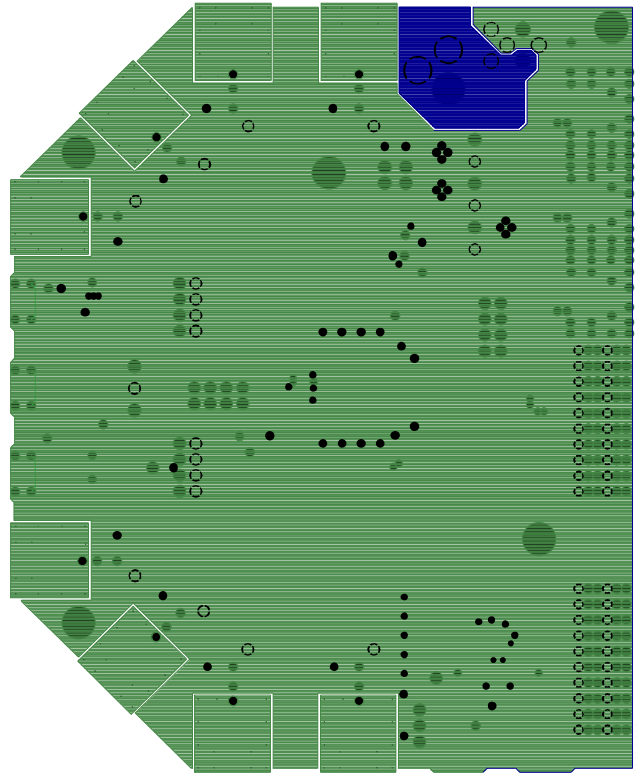

Figure 85. Evaluation Board Layout, Ground Plane (Layer 5)

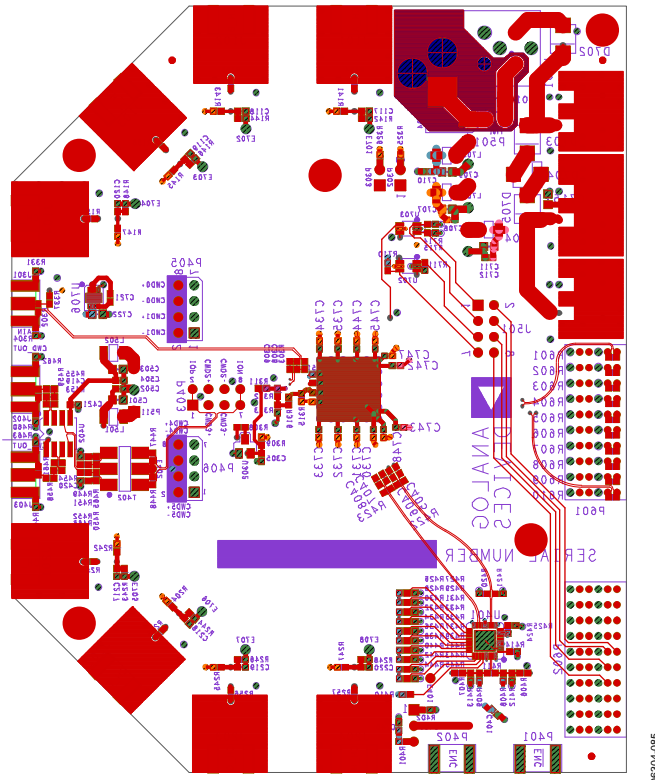

Figure 86. Evaluation Board Layout, Bottom Side

# AD9271

Table 16. Evaluation Board Bill of Materials (BOM)<sup>1</sup>

Item	Qty.	Reference Designator	Device	Package	Description	Manufacturer	RoHS Part Number
1	70	C101, C103, C105, C107, C109, C111, C113, C115, C121, C122, C123, C124, C201, C203, C205, C207, C209, C211, C213, C215, C221, C222, C223, C224, C301, C303, C304, C305, C306, C308, C309, C401, C402, C403, C409, C410, C411, C412, C413, C414, C415, C416, C417, C418, C419, C420, C421, C422, C502, C504, C702, C703, C708, C710, C712, C730, C731, C732, C733, C734, C735, C740, C742, C743, C744, C745, C746, C747, C748, C751	Capacitor	402	0.1 µF, ceramic, X5R, 10 V, 10% tol	Panasonic AVX Murata	ECJ-0EB1A104K <sup>2</sup> 0402YD104KAT2A <sup>2</sup> GRM155R71C104KA88D <sup>2</sup>
2	1	C302	Capacitor	603	4.7 µF, 6.3 V, X5R, 10% tol	AVX Murata	06036D475KAT2A GRM188R60J475KE19D
3	9	C307, C714, C715, C716, C717, C719, C720, C722, C723	Capacitor	603	1 µF, ceramic, X5R, 6.3 V, 10% tol	Panasonic Murata	ECJ-1VB0J105K <sup>2</sup> GRM188R61C105KA93D <sup>2</sup>
4	8	C102, C106, C110, C114, C202, C206, C210, C214	Capacitor	402	22 pF, ceramic, NPO, 5% tol, 50 V	Kemet AVX Murata	C0402C220J5GACTU <sup>2</sup> 04025A220JAT2A <sup>2</sup> GRM1555C1H220JZ01D <sup>2</sup>
5	1	C721	Capacitor	402	100 pF, ceramic, COG, 50 V, 5% tol	Murata	GRM1555C1H101JZ01D <sup>2</sup>
6	1	C704	Capacitor	1812	10 µF, X5S, 50 V, 20% tol	Taiyo Yuden	UMK432C106MM-T <sup>2</sup>
7	5	C501, C503, C707, C709, C711	Capacitor	603	10 µF, ceramic, X5R, 6.3 V, 20% tol	Panasonic Murata	ECJ-1VB0J106M <sup>2</sup> GRM188R60J106M <sup>2</sup>
8	1	CR401	Diode	SOT23	30 V, 20 mA, dual Schottky	Avago Technologies Limited (Agilent)	HSMS-2812-TR1G
9	1	CR702	LED	603	Green, 4 V, 5 m candela	Panasonic	LNJ314G8TRA <sup>2</sup>
10	5	D701, D702, D703, D704, D705	Diode	DO-214AB	3 A, 30 V, SMC	Micro Commercial Co.	S2A-TP <sup>2</sup>
11	1	F701	Fuse	1210	6.0 V, 2.2 A trip current resettable fuse	Tyco/Raychem	NANOSMDC110F-2 <sup>2</sup>
12	8	L401, L402, L403, L404, L405, L406, L407, L408	Inductor	1210	560 µH, test freq 1 kHz, 5% tol, 40 mA	Murata	LQH32MN561J23L <sup>2</sup>
13	8	L501, L502, L702, L703, L704, L705, L706, L707	Ferrite bead	1210	10 µH, test freq 100 MHz, 25% tol, 500 mA	Murata	BLM31PG500SH1L <sup>2</sup>
14	1	L701	Choke coil	5-pin	25 V dc, 15 A, 100 kHz to 1 GHz, 40 dB insertion loss	Murata	BNX016-01

Item	Qty.	Reference Designator	Device	Package	Description	Manufacturer	RoHS Part Number
15	2	J501, P403	Connector	8-pin	100 mil header, male, 2 × 4 double row straight	Samtec	TSW-104-08-T-D <sup>2</sup>
16	2	P302, P303	Connector	2-pin	100 mil header jumper, 1 × 2	Samtec	TSW-102-07-G-S <sup>2</sup>
17	2	P405, P406	Connector	8-pin	100 mil header, female, 2 × 4 double row straight	Samtec	SSW-104-06-G-D <sup>2</sup>
18	1	P511	Connector	3-pin	3.5 mm header strip, male, 1 × 3 single row straight	Wieland	Z5.531.3325.0 <sup>2</sup>
19	1	J401	Connector	3-pin	100 mil header jumper, 1 × 3	Samtec	TSW-103-07-G-S <sup>2</sup>
20	13	J101, J102, J103, J104, J201, J202, J203, J204, J301, J402, J403, P401, P402	Connector	SMA	Side mount SMA for 0.063 in. board thickness	Samtec	SMA-J-P-H-ST-EM1 <sup>2</sup>
21	2	P601, P602	Connector	HEADER	1469169-1, right angle 2-pair, 25 mm, header assembly	Tyco/AMP	1469169-1 NEW 6469169-1
22	1	P701	Connector	0.08", PCMT	RAPC722, power supply connector	Switchcraft	RAPC722X <sup>2</sup>
23	85	R102, R103, R105, R106, R111, R112, R114, R115, R120, R121, R123, R124, R129, R130, R131, R132, R133, R137, R138, R139, R140, R149, R151, R152, R153, R162, R163, R164, R202, R203, R205, R206, R211, R213, R214, R215, R220, R221, R223, R224, R229, R230, R232, R233, R237, R238, R239, R240, R249, R250, R251, R252, R253, R262, R263, R264, R304, R317, R331, R403, R405, R415, R416, R417, R418, R425, R427, R429, R431, R433, R435, R436, R439, R441, R443, R445, R446, R450, R451, R452, R460, R462, R463, R464, R466	Resistor	402	0 Ω, 1/16 W, 5% tol	Panasonic KOA Yageo NIC Components	ERJ-2GE0R00X <sup>2</sup> RK73Z1ETTP <sup>2</sup> RC0402JR-070RL <sup>2</sup> NRC04Z0TRF <sup>2</sup>
24	8	R108, R117, R126, R135, R208, R217, R226, R235	Resistor	402	200 Ω, 1/16 W, 5% tol	NIC Components	NRC04J201TRF <sup>2</sup>
25	12	R158, R159, R160, R161, R258, R259, R260, R261, R302, R404, R455, R458	Resistor	402	49.9 Ω, 1/16 W, 0.5% tol	Susumu Co.	RR0510R-49R9-D <sup>2</sup>
26	9	R301, R338, R401, R402, R410, R413, R711, R714, R715	Resistor	402	10 kΩ, 1/16 W, 5% tol	Panasonic KOA Yageo NIC Components	ERJ-2GEJ103X <sup>2</sup> RK73B1ETTP103J <sup>2</sup> RC0402JR-0710KL <sup>2</sup> NRC04J103TRF <sup>2</sup>

# AD9271

Item	Qty.	Reference Designator	Device	Package	Description	Manufacturer	RoHS Part Number
27	3	R303, R422, R423	Resistor	402	100 Ω, 1/16 W, 1% tol	Panasonic KOA Yageo	ERJ-2RKF1000X <sup>2</sup> RK73H1ETTP1000F <sup>2</sup> RC0402FR-07100RL <sup>2</sup> NRC04F1000TRF <sup>2</sup>
28	7	R309, R319, R325, R326, R710, R712, R713	Resistor	402	1 kΩ, 1/16 W, 1% tol	Panasonic KOA Yageo NIC Components	ERJ-2RKF1001X <sup>2</sup> RK73H1ETTP1001F <sup>2</sup> RC0402FR-071KL <sup>2</sup> NRC04F1001TRF <sup>2</sup>
29	1	R308	Resistor	402	470 kΩ, 1/16 W, 5% tol	Panasonic KOA Yageo NIC Components	ERJ-2GEJ474X <sup>2</sup> RK73B1ETTP474J <sup>2</sup> RC0402JR-07470KL <sup>2</sup> NRC04J474TRF <sup>2</sup>
30	2	R310, R336	Potentiometer	3-lead	10 kΩ, cermet trimmer potentiometer, 18-turn top adjust, 10%, 1/2 W	Murata	PVA2A103A01R00 <sup>2</sup>
31	1	R414	Resistor	402	4.12 kΩ, 1/16 W, 1% tol	Panasonic NIC Components	ERJ-2RKF4121X <sup>2</sup> NRC04F4121TRF <sup>2</sup>
32	3	R420, R421, R716	Resistor	402	240 Ω, 1/16 W, 5% tol	Yageo NIC Components	RC0402JR-07240RL <sup>2</sup> NRC04J241TRF <sup>2</sup>
33	1	R335	Resistor	402	8.06 kΩ, 1/16 W, 1% tol	NIC Components	NRC04F8061TRF <sup>2</sup>
34	2	R447, R448	Resistor	402	127 Ω, 1/16 W, 1% tol	NIC Components	NRC04F1270TRF <sup>2</sup>
35	6	R453, R454, R467, R468, R469, R470	Resistor	402	750 Ω, 1/16 W, 5% tol	NIC Components	NRC04J751TRF <sup>2</sup>
36	1	OSC401	Oscillator	Surface mount	Osc clock 50.000 MHz SMD	Valpey Fisher CTS	VFAC3-BHL-50MHz CB3LV-3C-50M0000-T
37	9	T101, T102, T103, T104, T201, T202, T203, T204, T401	Transformer	CD542	75 Ω, 1:1 impedance ratio transformer, 0.4 MHz to 800 MHz	Mini-Circuits®	ADT1-1WT+
38	1	T402	Transformer	CD637	50 Ω, 1:4 impedance ratio transformer, 0.2 MHz to 120 MHz	Mini-Circuits	ADTT4-1+
39	1	U301	IC	SV-100-3	Octal LNA/VGA/AAF/ADC and crosspoint switch	Analog Devices	AD9271BSVZ-50
40	1	U302	IC	SOT23	1.0 V precision low noise shunt voltage reference	Analog Devices	ADR510ARTZ
41	1	U401	IC	LFCSP32-5X5	Clock dist.	Analog Devices	AD9515BCPZ

Item	Qty.	Reference Designator	Device	Package	Description	Manufacturer	RoHS Part Number
42	1	U402	IC	SO8	Dual current feedback op amp, SO8	Analog Devices	AD812ARZ
43	1	U706	IC	CP-8	500 mA, low noise, low dropout reg	Analog Devices	ADP3335ACPZ-2.5
44	2	U704, U707	IC	SOT223-2	Regulator	Analog Devices	ADP3339AKCZ-1.8
45	1	U705	IC	SOT223-2	Regulator	Analog Devices	ADP3339AKCZ-3.3
46	1	U702	IC	SC88	NC7WZ07, dual buffer, SC88	Fairchild	NC7WZ07P6X_NL <sup>2</sup>
47	1	U703	IC	SC88	NC7WZ16P6X, UHS dual buffer, SC88	Fairchild	NC7WZ16P6X_NL <sup>2</sup>

<sup>1</sup> This BOM is RoHS compliant.

<sup>2</sup> May use suitable alternative.

OUTLINE DIMENSIONS

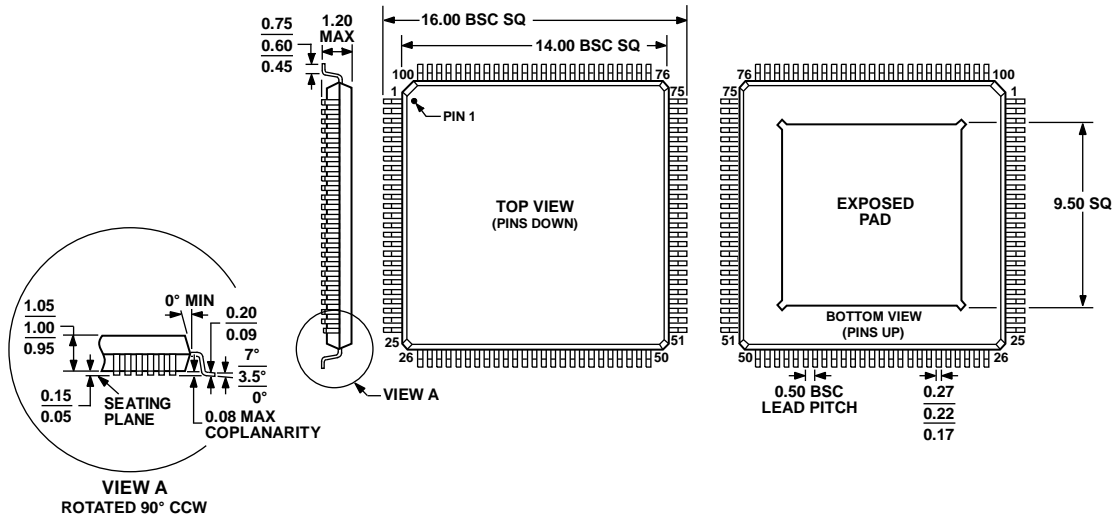

COMPLIANT TO JEDEC STANDARDS MS-026-AED-HD

NOTES:  
 THE PACKAGE HAS A CONDUCTIVE HEAT SLUG TO HELP DISSIPATE HEAT AND ENSURE RELIABLE OPERATION OF THE DEVICE OVER THE FULL INDUSTRIAL TEMPERATURE RANGE. THE SLUG IS EXPOSED ON THE BOTTOM OF THE PACKAGE AND ELECTRICALLY CONNECTED TO CHIP GROUND. IT IS RECOMMENDED THAT NO PCB SIGNAL TRACES OR VIAS BE LOCATED UNDER THE PACKAGE THAT COULD COME IN CONTACT WITH THE CONDUCTIVE SLUG. ATTACHING THE SLUG TO A GROUND PLANE WILL REDUCE THE JUNCTION TEMPERATURE OF THE DEVICE WHICH MAY BE BENEFICIAL IN HIGH TEMPERATURE ENVIRONMENTS.

Figure 87. 100-Lead Thin Quad Flat Package, Exposed Pad [TQFP\_EP] (SV-100-3)  
 Dimensions shown in millimeters

ORDERING GUIDE

Model	Temperature Range	Package Description	Package Option
AD9271BSVZ-50 <sup>1</sup>	-40°C to +85°C	100-Lead Thin Quad Flat Package, Exposed Pad [TQFP_EP]	SV-100-3
AD9271BSVZRL-50 <sup>1</sup>	-40°C to +85°C	100-Lead Thin Quad Flat Package, Exposed Pad [TQFP_EP] Tape and Reel	SV-100-3
AD9271BSVZ-40 <sup>1</sup>	-40°C to +85°C	100-Lead Thin Quad Flat Package, Exposed Pad [TQFP_EP]	SV-100-3
AD9271BSVZRL-40 <sup>1</sup>	-40°C to +85°C	100-Lead Thin Quad Flat Package, Exposed Pad [TQFP_EP] Tape and Reel	SV-100-3
AD9271BSVZ-25 <sup>1</sup>	-40°C to +85°C	100-Lead Thin Quad Flat Package, Exposed Pad [TQFP_EP]	SV-100-3
AD9271BSVZRL-25 <sup>1</sup>	-40°C to +85°C	100-Lead Thin Quad Flat Package, Exposed Pad [TQFP_EP] Tape and Reel	SV-100-3

<sup>1</sup> Z = RoHS Compliant Part.

**NOTES**

**AD9271**

**NOTES**

Компания «Life Electronics» занимается поставками электронных компонентов импортного и отечественного производства от производителей и со складов крупных дистрибьюторов Европы, Америки и Азии.

С конца 2013 года компания активно расширяет линейку поставок компонентов по направлению коаксиальный кабель, кварцевые генераторы и конденсаторы (керамические, пленочные, электролитические), за счёт заключения дистрибьюторских договоров

Мы предлагаем:

- Конкурентоспособные цены и скидки постоянным клиентам.
- Специальные условия для постоянных клиентов.
- Подбор аналогов.
- Поставку компонентов в любых объемах, удовлетворяющих вашим потребностям.
- Приемлемые сроки поставки, возможна ускоренная поставка.
- Доставку товара в любую точку России и стран СНГ.
- Комплексную поставку.
- Работу по проектам и поставку образцов.
- Формирование склада под заказчика.
- Сертификаты соответствия на поставляемую продукцию (по желанию клиента).
- Тестирование поставляемой продукции.
- Поставку компонентов, требующих военную и космическую приемку.
- Входной контроль качества.
- Наличие сертификата ISO.

В составе нашей компании организован Конструкторский отдел, призванный помогать разработчикам, и инженерам.

Конструкторский отдел помогает осуществить:

- Регистрацию проекта у производителя компонентов.
- Техническую поддержку проекта.
- Защиту от снятия компонента с производства.
- Оценку стоимости проекта по компонентам.
- Изготовление тестовой платы монтаж и пусконаладочные работы.



Тел: +7 (812) 336 43 04 (многоканальный)

Email: [org@lifeelectronics.ru](mailto:org@lifeelectronics.ru)