

## Brief Description

The ZSPM1000 is a configurable true-digital single-phase PWM controller for high-current, non-isolated DC/DC supplies. It operates as a synchronous step-down converter in a single-rail and single-phase configuration.

The ZSPM1000 integrates a digital control loop, optimized for maximum flexibility and stability, as well as load step and steady-state performance. In addition, a rich set of protection and monitoring functions is provided. On-chip, non-volatile memory (NVM) and an I<sup>2</sup>C™ interface facilitate configuration.

The PC-based IDT's Pink Power Designer™ provides a user-friendly and easy-to-use interface to the device for communication and configuration. It can guide the user through the design of the digital compensator and offers intuitive configuration methods for additional features, such as protection and sequencing.

## Features

- Programmable digital control loop
- Advanced digital control techniques
  - Tru-sample Technology™
  - State-Law Control™ (SLC)
  - Sub-cycle Response™ (SCR)
- Improved transient response and noise immunity
- Protection features
  - Over-current protection
  - Over-voltage protection (VIN, VOUT)
  - Under-voltage protection (VIN, VOUT)
  - Overloaded startup
  - Restart and delay
- Support for SMOD and ZCD drivers
- Fuse-based NVM for improved reliability
- Operation from a single 5V or 3.3V supply
- Optional PMBus™ address selection without external resistors

## Benefits

- Fast configurability and design flexibility
- Simplified design and integration
- Reduced component count through system level integration
- Simplified monitoring for system power and thermal management
- Higher energy efficiency across all output loading conditions

## Available Support

- Evaluation Kit
- PC-based Pink Power Designer™

## Physical Characteristics

- Operation temperature: -40°C to +125°C\*\*
- V<sub>OUT</sub> max: 5V
- Lead free (RoHS compliant) 24-pin QFN package (4 mm x 4 mm)

## ZSPM1000 Typical Application Diagram

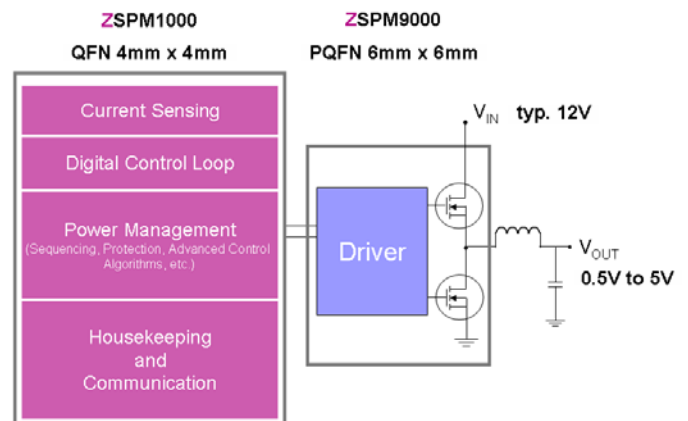

™ I<sup>2</sup>C™ is a registered trademark of NXP.

\*\* Subject to product type.

## ZSPM1000 Block Diagram

- Typical Applications**
- ❖ Telecom Switches
  - ❖ Servers and Storage
  - ❖ Base Stations
  - ❖ Network Routers
  - ❖ Industrial Applications
  - ❖ Single-Rail/Single-Phase Supplies for Processors, ASICs, FPGAs, DSPs



## Ordering Information

Sales Code	Description	Package
ZSPM1000ZI1R 1	ZSPM1000 Lead-free QFN24 — Temperature range: -40°C to +85°C *	Reel
ZSPM1000ZA1R 1	ZSPM1000 Lead-free QFN24 — Temperature range: -40°C to +125°C *	Reel
ZSPM8000-KIT	Evaluation Kit for ZSPM1000 with PMBus™ Communication Interface	Kit

\* This product is sold under a limited license from PowerOne, Inc. related to digital power technology as set forth in U.S. Patent 7000125 and other related patents owned by PowerOne, Inc. This license does not extend to stand-alone power supply products.



Corporate Headquarters  
6024 Silver Creek Valley Road  
San Jose, CA 95138  
[www.IDT.com](http://www.IDT.com)

Sales  
1-800-345-7015 or 408-284-8200  
Fax: 408-284-2775  
[www.IDT.com/go/sales](http://www.IDT.com/go/sales)

Tech Support  
[www.IDT.com/go/support](http://www.IDT.com/go/support)

DISCLAIMER Integrated Device Technology, Inc. (IDT) reserves the right to modify the products and/or specifications described herein at any time, without notice, at IDT's sole discretion. Performance specifications and operating parameters of the described products are determined in an independent state and are not guaranteed to perform the same way when installed in customer products. The information contained herein is provided without representation or warranty of any kind, whether express or implied, including, but not limited to, the suitability of IDT's products for any particular purpose, an implied warranty of merchantability, or non-infringement of the intellectual property rights of others. This document is presented only as a guide and does not convey any license under intellectual property rights of IDT or any third parties.

IDT's products are not intended for use in applications involving extreme environmental conditions or in life support systems or similar devices where the failure or malfunction of an IDT product can be reasonably expected to significantly affect the health or safety of users. Anyone using an IDT product in such a manner does so at their own risk, absent an express, written agreement by IDT.

Integrated Device Technology, IDT and the IDT logo are trademarks or registered trademarks of IDT and its subsidiaries in the United States and other countries. Other trademarks used herein are the property of IDT or their respective third party owners. For datasheet type definitions and a glossary of common terms, visit [www.idt.com/go/glossary](http://www.idt.com/go/glossary). All contents of this document are copyright of Integrated Device Technology, Inc. All rights reserved.

Компания «Life Electronics» занимается поставками электронных компонентов импортного и отечественного производства от производителей и со складов крупных дистрибьюторов Европы, Америки и Азии.

С конца 2013 года компания активно расширяет линейку поставок компонентов по направлению коаксиальный кабель, кварцевые генераторы и конденсаторы (керамические, пленочные, электролитические), за счёт заключения дистрибьюторских договоров

Мы предлагаем:

- Конкурентоспособные цены и скидки постоянным клиентам.
- Специальные условия для постоянных клиентов.
- Подбор аналогов.
- Поставку компонентов в любых объемах, удовлетворяющих вашим потребностям.
- Приемлемые сроки поставки, возможна ускоренная поставка.
- Доставку товара в любую точку России и стран СНГ.
- Комплексную поставку.
- Работу по проектам и поставку образцов.
- Формирование склада под заказчика.
- Сертификаты соответствия на поставляемую продукцию (по желанию клиента).
- Тестирование поставляемой продукции.
- Поставку компонентов, требующих военную и космическую приемку.
- Входной контроль качества.
- Наличие сертификата ISO.

В составе нашей компании организован Конструкторский отдел, призванный помогать разработчикам, и инженерам.

Конструкторский отдел помогает осуществить:

- Регистрацию проекта у производителя компонентов.
- Техническую поддержку проекта.
- Защиту от снятия компонента с производства.
- Оценку стоимости проекта по компонентам.
- Изготовление тестовой платы монтаж и пусконаладочные работы.



Тел: +7 (812) 336 43 04 (многоканальный)  
Email: [org@lifeelectronics.ru](mailto:org@lifeelectronics.ru)