



Features

- For Use in Both 50Ω and 75Ω Systems
- 5 MHz to 1500MHz Operation
- Internally Matched Input and Output
- 20dB Small Signal Gain
- 1.2dB Noise Figure
- +24dBm Output Power
- Single 5V to 9V Positive Power Supply

Applications

- Linear LNA/Driver
- CATV Distribution Amplifiers
- Cable Modems
- Broadband Gain Blocks
- Laser Diode Driver
- Return Channel Amplifier
- Base Stations

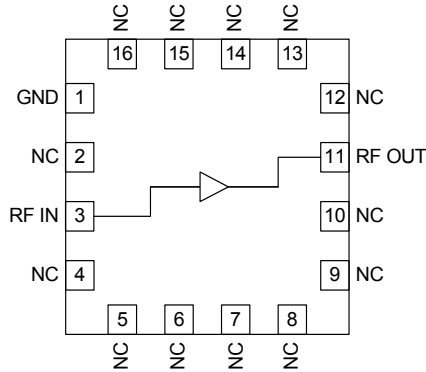

Functional Block Diagram

Product Description

The RF3827 is a general purpose, low-cost, high-linearity RF amplifier IC. The device is manufactured on a Gallium Arsenide process and is featured in a 3mm x 3mm, 16-pin, QFN package. It is ideally suited for use as a linear/low noise amplifier, with OIP3 equal to 38dBm and noise figure less than 1.5dB.

Ordering Information

RF3827SQ	Sample bag with 25 pieces
RF3827SR	7" Sample reel with 100 pieces
RF3827TR7	7" Reel with 2500 pieces
RF3827PCK-410	5MHz to 1500MHz PCBA with 5-piece sample bag

Optimum Technology Matching® Applied

- | | | | |
|---|--------------------------------------|-------------------------------------|-----------------------------------|
| <input type="checkbox"/> GaAs HBT | <input type="checkbox"/> SiGe BiCMOS | <input type="checkbox"/> GaAs pHEMT | <input type="checkbox"/> GaN HEMT |
| <input checked="" type="checkbox"/> GaAs MESFET | <input type="checkbox"/> Si BiCMOS | <input type="checkbox"/> Si CMOS | <input type="checkbox"/> RF MEMS |
| <input type="checkbox"/> InGaP HBT | <input type="checkbox"/> SiGe HBT | <input type="checkbox"/> Si BJT | <input type="checkbox"/> LDMOS |

RF MICRO DEVICES®, RFMD®, Optimum Technology Matching®, Enabling Wireless Connectivity™, PowerStar®, POLARIS™ TOTAL RADIO™ and UltimateBlue™ are trademarks of RFMD, LLC. BLUETOOTH is a trademark owned by Bluetooth SIG, Inc., U.S.A. and licensed for use by RFMD. All other trade names, trademarks and registered trademarks are the property of their respective owners. ©2006, RF Micro Devices, Inc.

Absolute Maximum Ratings

Parameter	Rating	Unit
Device Current	175	mA
Device Voltage	9	V
Input RF Power	+13	dBm
Output Load VSWR	20:1	
Ambient Operating Temperature	-40 to +85	°C
Storage Temperature	-40 to +150	°C



Caution! ESD sensitive device.

Exceeding any one or a combination of the Absolute Maximum Rating conditions may cause permanent damage to the device. Extended application of Absolute Maximum Rating conditions to the device may reduce device reliability. Specified typical performance or functional operation of the device under Absolute Maximum Rating conditions is not implied.

RoHS status based on EU Directive 2011/65/EU (at time of this document revision).

The information in this publication is believed to be accurate and reliable. However, no responsibility is assumed by RF Micro Devices, Inc. ("RFMD") for its use, nor for any infringement of patents, or other rights of third parties, resulting from its use. No license is granted by implication or otherwise under any patent or patent rights of RFMD. RFMD reserves the right to change component circuitry, recommended application circuitry and specifications at any time without prior notice.



RFMD Green: RoHS compliant per EU Directive 2011/65/EU, halogen free per IEC 61249-2-21, < 1000 ppm each of antimony trioxide in polymeric materials and red phosphorus as a flame retardant, and <2% antimony in solder.

Parameter	Specification			Unit	Condition
	Min.	Typ.	Max.		
Overall (50Ω)					T = 25 °C, V _{DD} = 8V, 50Ω Evaluation Board
Frequency Range	50		1000	MHz	
Gain		20.5		dB	At 500MHz
Gain Flatness		+/-1.0		dB	50MHz to 1000MHz
Noise Figure		1.3		dB	50MHz to 1000MHz
Output IP ₃		38		dBm	50MHz to 1000MHz
Output P _{1dB}		25±1.0		dBm	50MHz to 1000MHz
Reverse Isolation		24		dB	50MHz to 1000MHz

Parameter	Specification			Unit	Condition
	Min.	Typ.	Max.		
Thermal					
Theta JC		40		°C/W	Referenced to the GND via of Pin 1
Maximum Junction Temperature			150	°C	
Power Supply					
Supply Voltage (V _{DD})	5	7	9	V	
Operating Current Range	115	120	130	mA	

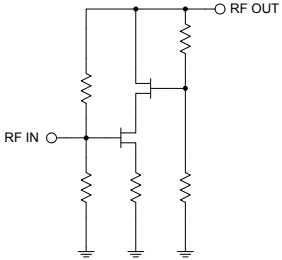
Pin	Function	Description	Interface Schematic
1	GND	Keep traces physically short. Connect this pin to the ground plane with a via.	
2	NC	No internal connection. Externally connected to RF input trace.	
3	RF IN	RF input pin. This pin is internally DC blocked. An external DC blocking capacitor is not required.	
4	NC	No connection. This pin should be connected to the ground plane.	
5	NC	No connection. This pin should be connected to the ground plane.	
6	NC	No connection. This pin should be connected to the ground plane.	
7	NC	No connection. This pin should be connected to the ground plane.	
8	NC	No connection. This pin should be connected to the ground plane.	
9	NC	No connection. This pin should be connected to the ground plane.	
10	NC	No internal connection. Externally connected to RF output trace.	
11	RF OUT	RF output and bias pin. Because DC is present on this pin, a DC blocking capacitor, suitable for the frequency of operation, should be used in most applications. For biasing, only an RF choke is needed.	
12	NC	No connection. This pin should be connected to the ground plane.	
13	NC	No connection. This pin should be connected to the ground plane.	
14	NC	No connection. This pin should be connected to the ground plane.	
15	NC	No connection. This pin should be connected to the ground plane.	
16	NC	No connection. This pin should be connected to the ground plane.	
Pkg Base	GND		

Package Drawing

Package Style: QFN, 16-Pin, 3mmx3mm

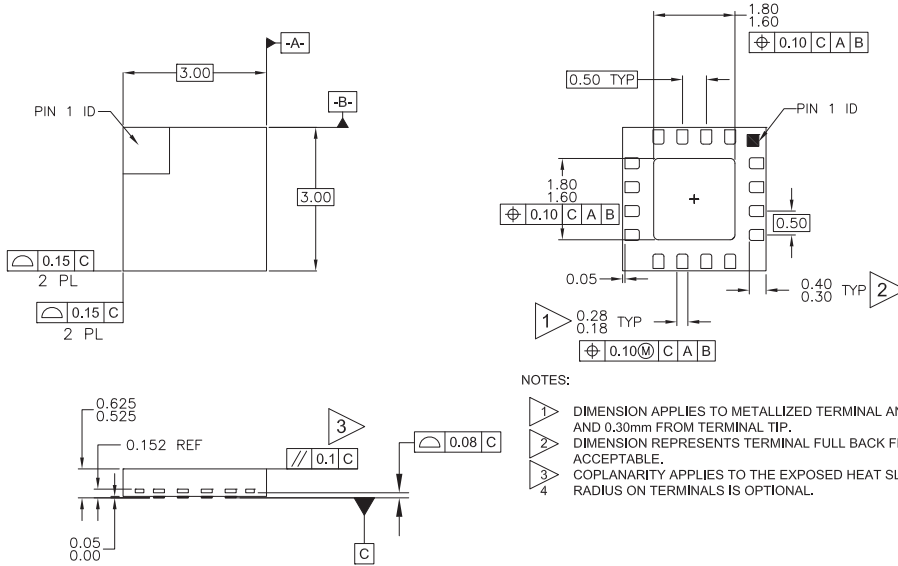

Application Schematic - 50Ω 5 MHz to 200 MHz Linear Driver

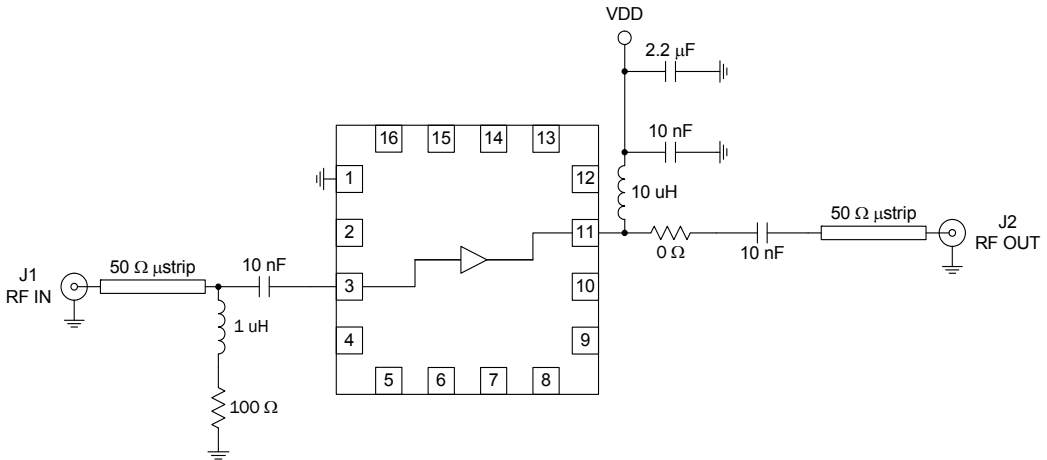

VCC (V)	Frequency MHz	ICC mA	Gain dB	OIP3 dBm	OP1dB dBm
8	5	99.945	18.92	33.7	21.69
8	10	100.437	18.63	37.75	22.86
8	100	101.093	19.53	38.47	25.21
8	200	101.221	19.8	38.6	25.45

Evaluation Board Schematic - 50Ω 50 MHz to 1000 MHz

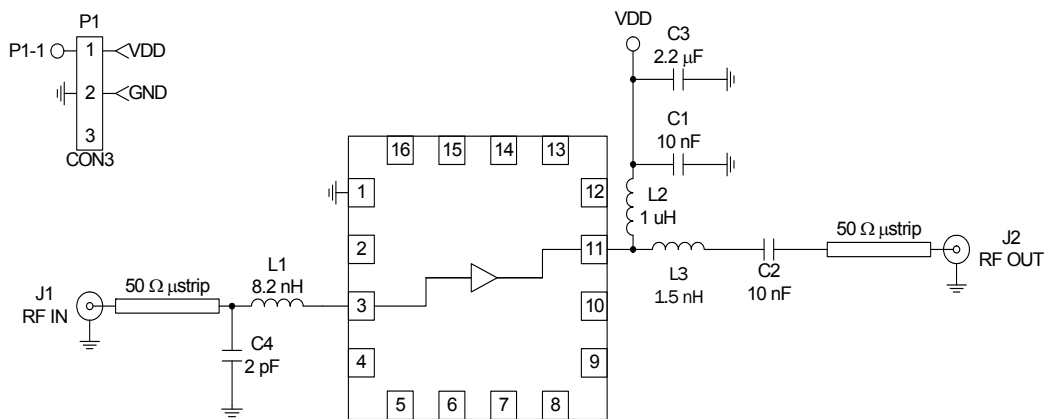

3827400, r.1

Evaluation Board Layout - 50Ω
Board Size 1.0" x 1.5"
Board Thickness 0.031", Board Material FR-4

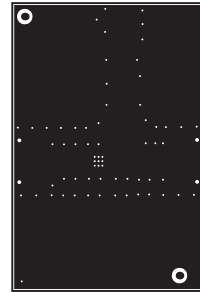
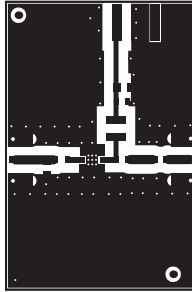
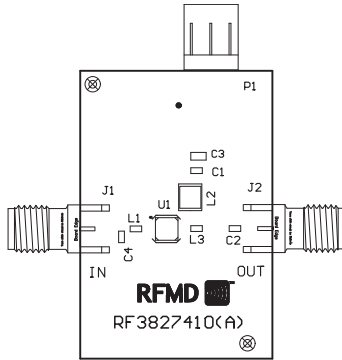

50 Ohm Evaluation Board
50MHz to 1000MHz, $V_{CC}=8V$

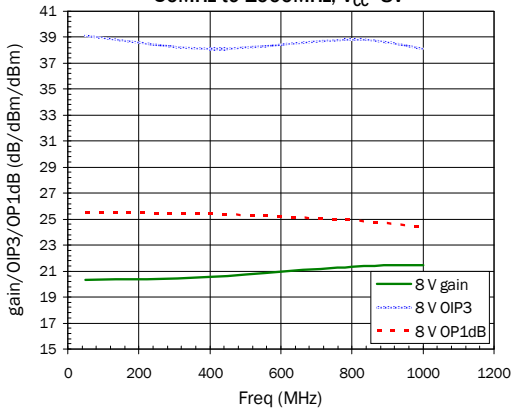

50 Ohm Evaluation Board
50MHz to 1000MHz, $V_{CC}=5V$

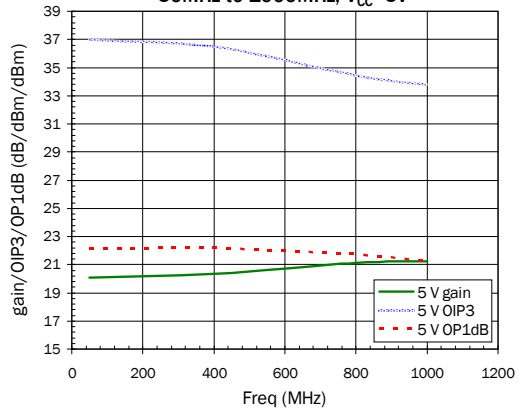

50 Ohm Evaluation Board
50MHz to 1000MHz, $V_{CC}=8V$
Noise Figure

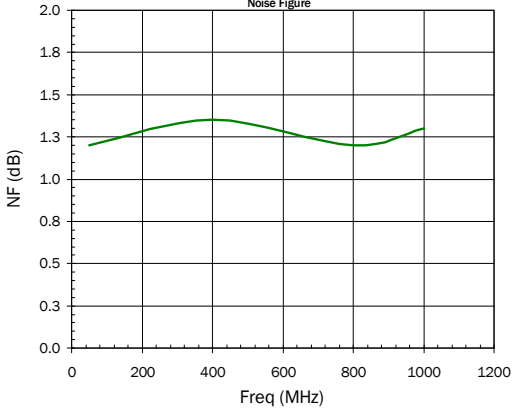

Theory of Operation

RF3827 can be used as both low noise amplifier and linear transmit driver. Internal matching is such that the part can be used effectively in both 50Ω and 75Ω systems. The standard evaluation board is 50Ω , as are the corresponding specifications shown within the data sheet. Perhaps more convenient for the 75Ω designer, would be alternate products RF2360 and CXE-2089Z. These two devices see very similar performance to RF3827, and standard 75Ω evaluation boards are available.

An important note concerning RF3827 layout would apply to package pins 2 and 10. These two pins have no internal connection. They are, however, connected externally to RF input and output traces on the standard evaluation board. Given their close proximity to the actual input and output pins, this is simply a matter of convenience.

The standard RF3827 evaluation board is matched to provide excellent performance from 50MHz to 1000MHz. An application schematic is also shown for 5MHz to 200MHz, in the event lower frequency operation is desired. Specifications are shown in the tabular sections for the condition $V_{DD}=8V$. Note that graphs are also provided herein for the common design case where $V_{DD}=5V$.

Компания «Life Electronics» занимается поставками электронных компонентов импортного и отечественного производства от производителей и со складов крупных дистрибьюторов Европы, Америки и Азии.

С конца 2013 года компания активно расширяет линейку поставок компонентов по направлению коаксиальный кабель, кварцевые генераторы и конденсаторы (керамические, пленочные, электролитические), за счёт заключения дистрибьюторских договоров

Мы предлагаем:

- Конкурентоспособные цены и скидки постоянным клиентам.
- Специальные условия для постоянных клиентов.
- Подбор аналогов.
- Поставку компонентов в любых объемах, удовлетворяющих вашим потребностям.
- Приемлемые сроки поставки, возможна ускоренная поставка.
- Доставку товара в любую точку России и стран СНГ.
- Комплексную поставку.
- Работу по проектам и поставку образцов.
- Формирование склада под заказчика.
- Сертификаты соответствия на поставляемую продукцию (по желанию клиента).
- Тестирование поставляемой продукции.
- Поставку компонентов, требующих военную и космическую приемку.
- Входной контроль качества.
- Наличие сертификата ISO.

В составе нашей компании организован Конструкторский отдел, призванный помогать разработчикам, и инженерам.

Конструкторский отдел помогает осуществить:

- Регистрацию проекта у производителя компонентов.
- Техническую поддержку проекта.
- Защиту от снятия компонента с производства.
- Оценку стоимости проекта по компонентам.
- Изготовление тестовой платы монтаж и пусконаладочные работы.



Тел: +7 (812) 336 43 04 (многоканальный)

Email: org@lifeelectronics.ru