

**Specification**  
**Quad Small Form-factor Pluggable**  
**Optical Transceiver Module**  
**100GBASE-PSM4**

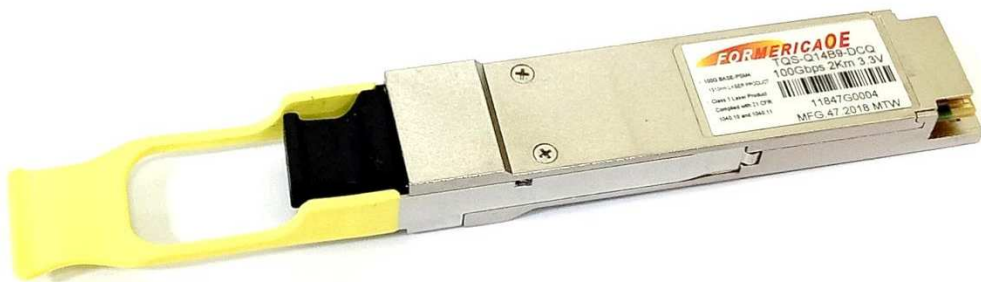

**Ordering Information**

**TQS-Q14B9-DCQ**

Model Name	Voltage	Category	Device type	Temperature	Distance
TQS-Q14B9-DCQ	3.3V	With DDMI	1310 nm DFB / PIN	0°C~+70°C	2km ( SMF)

## Features

- Compliant with 100G Ethernet IEEE 802.3bm
- Compliant to SFF-8665 (QSFP28 Solution)
- Supports 103.1Gb/s aggregate bit rate
- Low power consumption of max 3.5W
- Hot pluggable electrical interface
- Using standard 12-lane optical fiber with MPO pluggable optical connector
- 0 to 70°C case temperature operating range
- RoHS compliant

## Applications

- 100GBASE Ethernet links up to 2km over SMF.
- Infiniband QDR and DDR.

## Absolute Maximum Rating

Not necessarily applied together. Exceeding these values may cause permanent damage. Functional operation under these conditions is not implied.

Parameter	Symbol	Min	Typ.	Max	Unit	Note
Storage Temperature	Ts	-40		85	°C	
3.3V Power Supply Voltage	Vcc	-0.5		3.6	V	
Relative Humidity	RH	0		85	%	
Damage Threshold, each Lane	DT	3			dBm	

## Recommended Operating Conditions

Parameter	Min	Typical	Max	Unit	Note
Case Operating Temperature	0		70	°C	
Power Supply Voltage	3.135	3.3	3.465	V	
Date Rate per Channel		25.78125		Gbps	
Bit Error Ratio		10 <sup>-12</sup>			
Control Input Voltage High	2		Vcc	V	
Control Input Voltage Low	0		0.8	V	
Link Reach			2000	M	

## Electrical Characteristics

Parameter	Symbol	Min	Typ.	Max	Unit	Note
<b>Transceiver Electrical Characteristics</b>						
TRx Power Consumption				3.5	W	
Supply Current				1.06	A	
<b>Transmitter Electrical Characteristics</b>						
Data Input Differential Peak-to-Peak Voltage Swing	$\Delta V_{DI}$ PP	900			mVp p	
Common Mode Voltage (Vcm)		-350		2850	mV	1
Differential Input Return Loss		See CEI- 28G-VSR Equation 13-19			dB	
Differential to Common-mode Input Return Loss		See CEI- 28G-VSR Equation 13-20			dB	
<b>Receiver Electrical Characteristics</b>						
Differential Output Return Loss		See CEI- 28G-VSR Equation 13-19			dB	
Common Mode Output Return Loss		See CEI- 28G-VSR Equation 13-21			dB	
Differential Output Voltage				900	mV	
Eye Width		0.57			UI	
Eye Height, Differential		228			mV	

**Notes:**

1. Vcm is generated by the host. Specification includes effects of ground offset voltage.

## Optical Characteristics

Parameter	Symbol	Min	Typ.	Max	Unit	Note
<b>Transmitter Optical Characteristics</b>						
Center Wavelength	$\lambda$	1295	1310	1325	nm	
Side-Mode Suppression Ratio	SMSR	30			dB	
Average Output Optical Power	PO AVE	-5.5		2	dBm	
Output Optical Modulation Amplitude, per lane	OMA	-3.5		2.2	dBm	1
Extinction Ratio	ER	3.5			dB	
Optical Return Loss Tolerance	TOL			20	dB	
Transmitter Reflectance	RT			-12	dB	
Transmitter Eye Mask {X1, X2, X3, Y1, Y2, Y3}		{0.31, 0.4, 0.45, 0.34, 0.38, 0.4}				
<b>Receiver Optical Characteristics</b>						
Center wavelength, each lane	$\lambda$	1295	1310	1325	nm	
Damage Threshold		3			dBm	2
Average power at receiver input, each lane		-10.2		2	dBm	
Optical Modulation Amplitude (OMA)				2.2	dBm	
Receiver Sensitivity (OMA), each Lane	SEN1			-9	dBm	BER=1x10 <sup>-12</sup>
Stressed Receiver Sensitivity (OMA), each Lane				-6.44	dBm	BER=1x10 <sup>-12</sup>
Receiver Sensitivity (OMA), each Lane	SEN2			-11.35	dBm	BER=5x10 <sup>-5</sup>
Stressed Receiver Sensitivity (OMA), each Lane				-8.79	dBm	BER=5x10 <sup>-5</sup>
Receiver Reflectance				-26	dBm	
LOS Assert	LOSA	-30			dBm	
LOS Deassert	LOSD			-15	dBm	
LOS Hysteresis	LOSH	0.5			dB	

Notes:

1. Even if the TDP < 0.8 dB, the OMA min must exceed the minimum value specified here.
2. The receiver shall be able to tolerate, without damage, continuous exposure to a modulated optical input signal having this power level on one lane. The receiver does not have to operate correctly at this input power.
3. Measured with conformance test signal at TP3 for BER =  $5 \times 10^{-5}$

### QSFP28 Module Pad Assignments and Descriptions

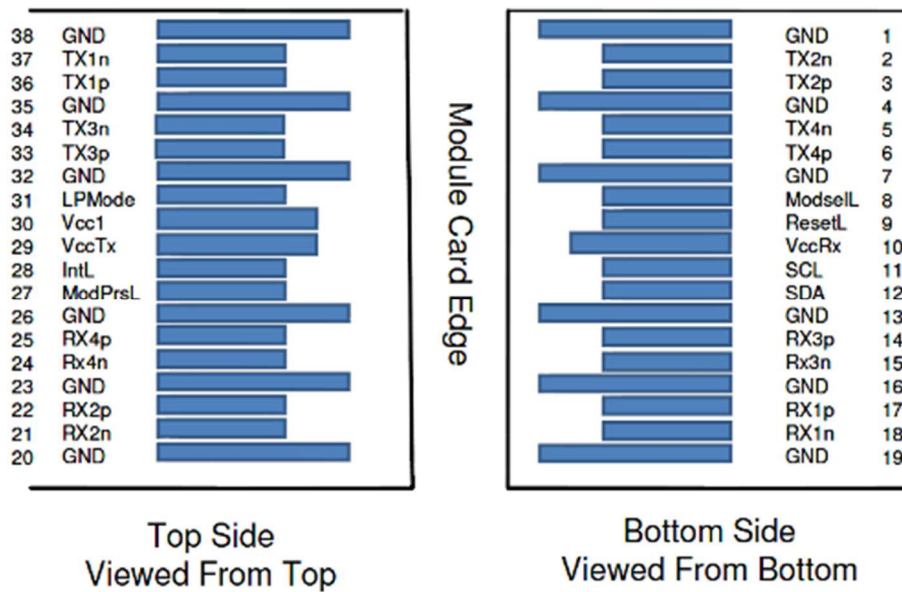

Pin	Logic	Symbol	Description	Plug Sequence	Notes
1		GND	Ground	1	
2	CML-I	Tx2n	Transmitter Inverted Data Input	3	
3	CML-I	Tx2p	Transmitter Non-Inverted Data Input	3	
4		GND	Ground	1	
5	CML-I	Tx4n	Transmitter Inverted Data Input	3	
6	CML-I	Tx4p	Transmitter Non-Inverted Data Input	3	
7		GND	Ground	1	
8	LVTTL-I	ModSelL	Module Select	3	
9	LVTTL-I	ResetL	Module Reset	3	
10		Vcc Rx	+3.3V Power Supply Receiver	2	
11	LVC MOS-I/O	SCL	2-wire serial interface clock	3	
12	LVC MOS-I/O	SDA	2-wire serial interface data	3	
13		GND	Ground	1	
14	CML-O	Rx3p	Receiver Non-Inverted Data Output	3	
15	CML-O	Rx3n	Receiver Inverted Data Output	3	
16		GND	Ground	1	
17	CML-O	Rx1p	Receiver Non-Inverted Data Output	3	
18	CML-O	Rx1n	Receiver Inverted Data Output	3	
19		GND	Ground	1	
20		GND	Ground	1	
21	CML-O	Rx2n	Receiver Inverted Data Output	3	
22	CML-O	Rx2p	Receiver Non-Inverted Data Output	3	
23		GND	Ground	1	
24	CML-O	Rx4n	Receiver Inverted Data Output	3	
25	CML-O	Rx4p	Receiver Non-Inverted Data Output	3	
26		GND	Ground	1	
27	LVTTL-O	ModPrsL	Module Present	3	
28	LVTTL-O	IntL	Interrupt	3	
29		Vcc Tx	+3.3V Power supply transmitter	2	
30		Vcc1	+3.3V Power supply	2	
31	LVTTL-I	LPMode	Low Power Mode	3	
32		GND	Ground	1	
33	CML-I	Tx3p	Transmitter Non-Inverted Data Input	3	
34	CML-I	Tx3n	Transmitter Inverted Data Input	3	
35		GND	Ground	1	

36	CML-I	Tx1p	Transmitter Non-Inverted Data Input	3	
37	CML-I	Tx1n	Transmitter Inverted Data Input	3	
38		GND	Ground	1	

**Recommended Host Board Power Supply Circuit**

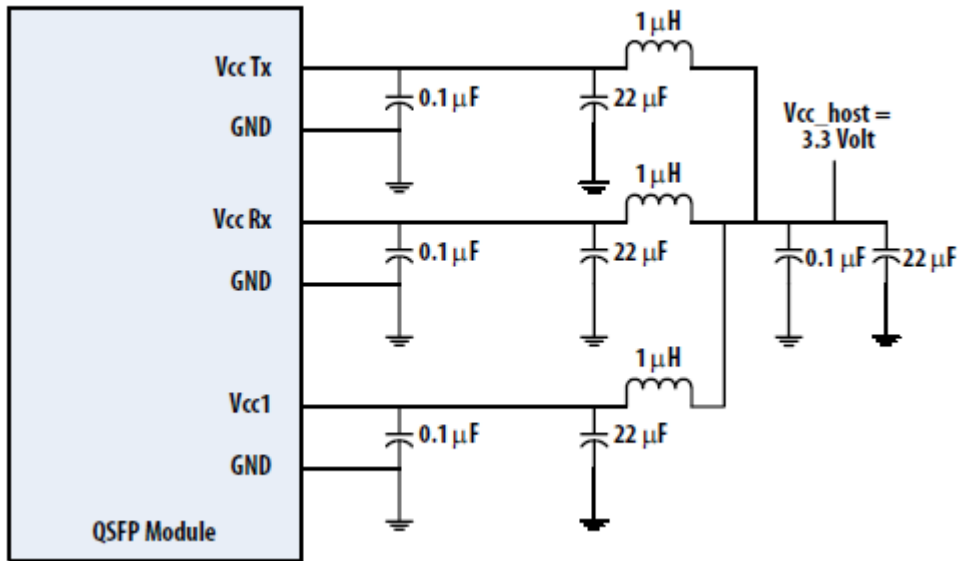

Recommended Interface Circuit

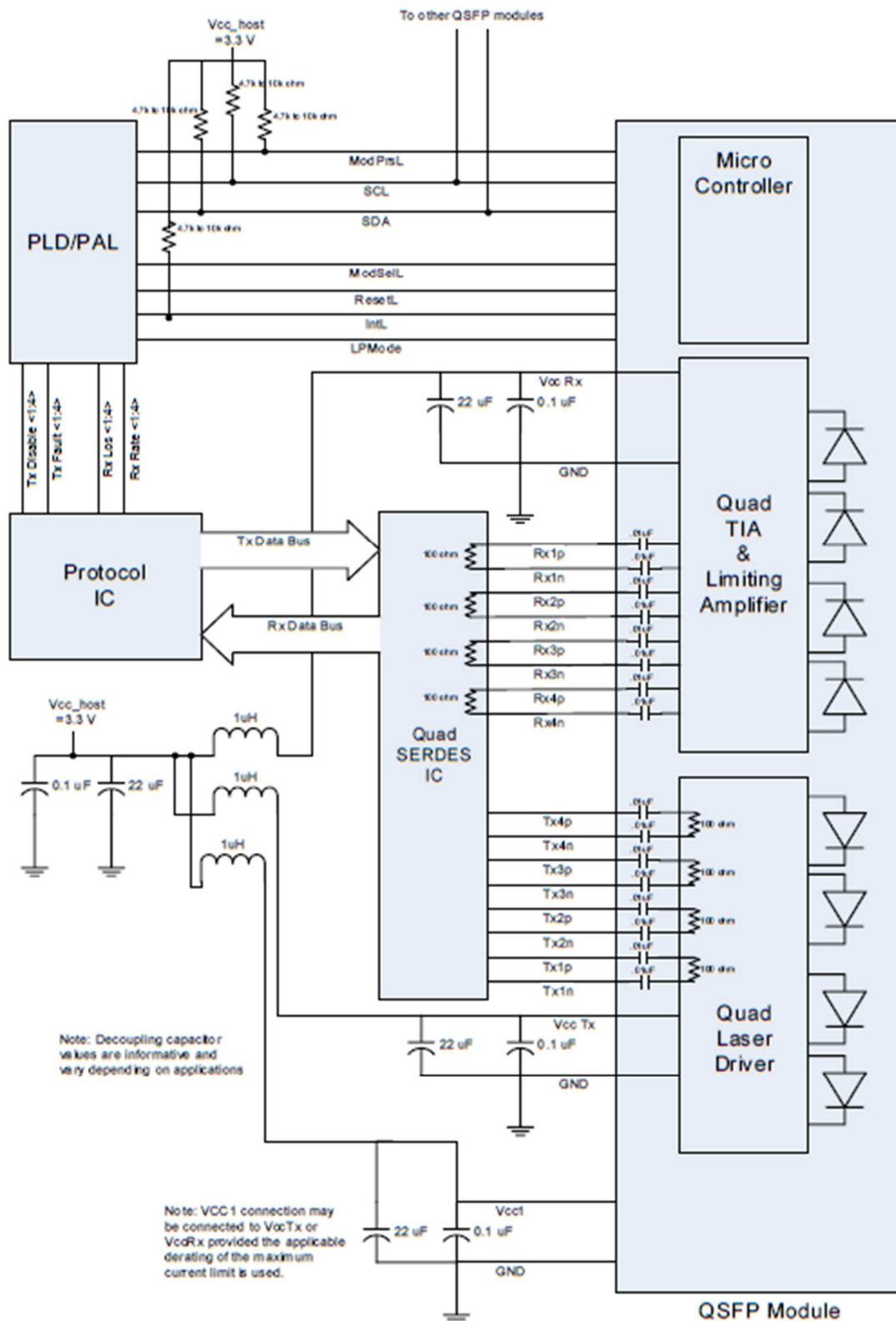



## Memory Map

The memory map is structured as a single address and multiple page approaches, according to the QSFP28 SFF-8636 MSA specification as shown in the below. For more detailed description of this memory map or lower pages, please see our Memory Map document with flexible customization settings.

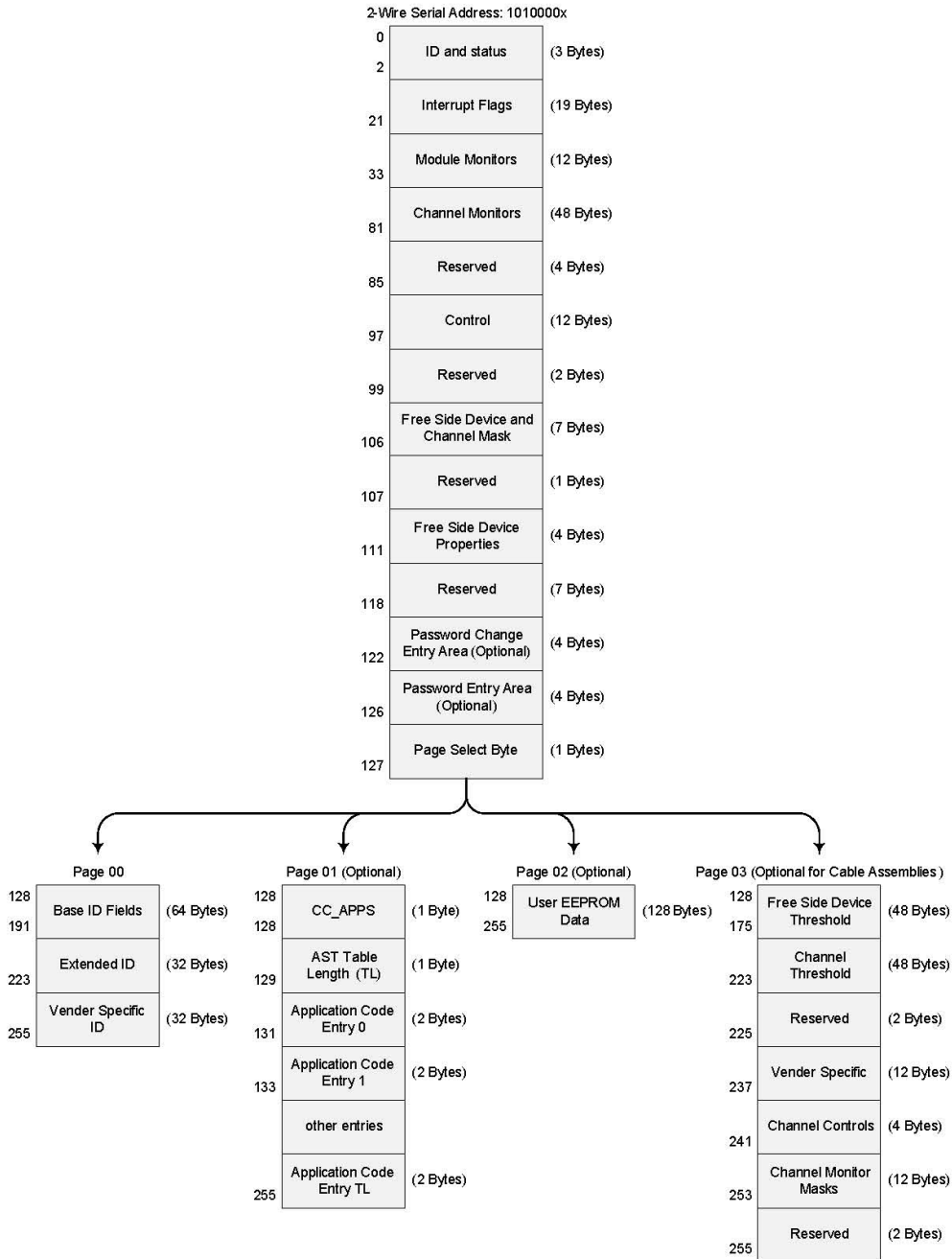

## Mechanical Design Diagram

Unit: mm

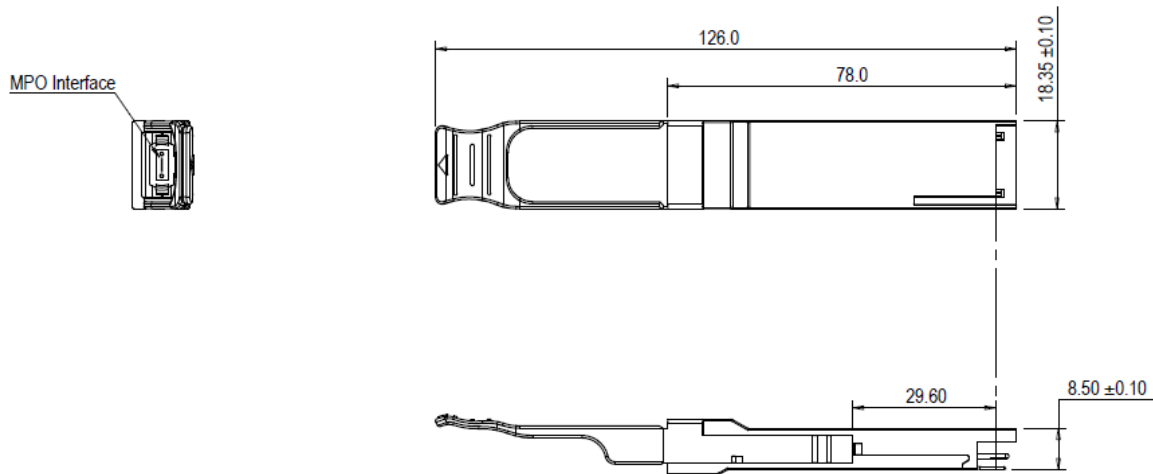

## ESD

Normal ESD precautions are required during the handling of this module. This transceiver is shipped in ESD protective packaging. It should be removed from the packaging and handled only in an ESD protected environment.

## Laser Safety

This is a Class 1 Laser Product according to IEC / EN 60825-1: 2014 (Third Edition). This product complies with 21 CFR 1040.10 and 1040.11 except for deviations pursuant to Laser Notice No. 50, dated (June 24, 2007).

## Contact Information

### Formerica OptoElectronics Inc.

5F-11, No.38, Taiyuan St., Zhubei City,

Hsinchu County 30265, Taiwan

Tel: +886-3-5600286

Fax: +886-3-5600239

### San Diego, CA

Tel: 1-949-466-8069

[inquiry@formericaoe.com](mailto:inquiry@formericaoe.com)

[www.formericaoe.com](http://www.formericaoe.com)

Компания «Life Electronics» занимается поставками электронных компонентов импортного и отечественного производства от производителей и со складов крупных дистрибьюторов Европы, Америки и Азии.

С конца 2013 года компания активно расширяет линейку поставок компонентов по направлению коаксиальный кабель, кварцевые генераторы и конденсаторы (керамические, пленочные, электролитические), за счёт заключения дистрибьюторских договоров

Мы предлагаем:

- Конкурентоспособные цены и скидки постоянным клиентам.
- Специальные условия для постоянных клиентов.
- Подбор аналогов.
- Поставку компонентов в любых объемах, удовлетворяющих вашим потребностям.
- Приемлемые сроки поставки, возможна ускоренная поставка.
- Доставку товара в любую точку России и стран СНГ.
- Комплексную поставку.
- Работу по проектам и поставку образцов.
- Формирование склада под заказчика.
- Сертификаты соответствия на поставляемую продукцию (по желанию клиента).
- Тестирование поставляемой продукции.
- Поставку компонентов, требующих военную и космическую приемку.
- Входной контроль качества.
- Наличие сертификата ISO.

В составе нашей компании организован Конструкторский отдел, призванный помогать разработчикам, и инженерам.

Конструкторский отдел помогает осуществить:

- Регистрацию проекта у производителя компонентов.
- Техническую поддержку проекта.
- Защиту от снятия компонента с производства.
- Оценку стоимости проекта по компонентам.
- Изготовление тестовой платы монтаж и пусконаладочные работы.



Тел: +7 (812) 336 43 04 (многоканальный)

Email: [org@lifeelectronics.ru](mailto:org@lifeelectronics.ru)