

Power Supply IC Series for TFT-LCD Panels

Gamma voltage generated IC with built-in DAC



BD8149MUV

No.12035EAT17

●Description

The feature of gamma voltage generated IC BD8149MUV provides a single-chip solution with a high-precision 10-bit DAC setting controlled by I2C serial communications interface and a Buffer AMP (12ch). EEPROM auto-read function is also incorporated.

●Features

- 1) Single-chip design realizes fewer components
- 2) Built in 10bit DAC
- 3) Built in DAC output buffer amplifier (12ch)
- 4) Double Register synchronous switching function (SEL)
- 5) I²C interface (SDA, SCL)
STANDARD-MODE, FAST-MODE changeable
- 6) EEPROM auto-read function
- 7) Thermal Shut Down circuit
- 8) Under Voltage Lock Out circuit
- 9) Power ON Reset circuit
- 10) Input tolerant (SDA, SCL, EN, EN_AR, SEL)
- 11) VQFN032V5050 package

●Applications

It may be used with TFT-LCD panels, such as big screen and high resolution LCD televisions.

●Absolute Maximum Ratings (Ta=25°C)

PARAMETER	SYMBOL	RATING	UNIT
Power supply voltage1	VDD	4.5	V
Power supply voltage2	VCC	19	V
REFIN voltage	VREFIN	5	V
DAC reference voltage	VDAC	7	V
Functional pin voltage	SEL, A0, A1, A2 EN, SLAVE/AR EN_AR	4.5	V
2-lines serial pin voltage	SDA, SCL	4.5	V
Junction voltage	Tjmax	150	°C
Power dissipation	Pd	4560* ¹	mW
Operating temperature range	Topr	-25~+85	°C
Storage temperature range	Tstg	-55~+150	°C

*1 To use the IC at temperature over 25°C, derate power rating by 19.52mW /°C.

When mounted on a 4-layer glass epoxy board measuring 74.2 x 74.2 x 1.6mm.

● Operating conditions (Ta=-25°C~85°C)

PARAMETER	SYMBOL	MIN	MAX	UNIT	CONDITION
Power supply voltage1	VDD	2.1	3.6	V	
Power supply voltage2	VCC	10	18	V	
REFIN voltage	VREFIN	2	3.5	V	VCC=10V
		2	3.56	V	VCC=11V
		2	3.62	V	VCC=12V
		2	3.68	V	VCC=13V
DAC reference voltage	VDAC	2.1	4.5	V	
Functional pin voltage 1	SEL, EN, EN_AR	-0.1	3.6	V	
Functional pin voltage 2	A0, A1, A2 SLAVE/AR	-0.1	VDD	V	
2-line serial pin voltage	SDA, SCL	-0.1	3.6	V	
AMP0 output current capability	I _{OA}	-40	-	mA	
AMP1~10 output current capability	I _{OB}	-20	20	mA	
AMP6 output current capability	I _{OC}	-40	40	mA	
AMP11 output current capability	I _{OD}	-	40	mA	
2-line serial frequency	FCLK	-	400	kHz	

●Electrical Characteristics (Unless otherwise specified, Ta=25°C, VDD=3.3V, VCC=15V, REFIN=3.5V)

PARAMETER	SYMB OL	LIMITS			UNIT	CONDITION
		MIN	TYP	MAX		
[Gamma Amplifier]						
Sink current capability (AMP0)	looA	-	-	-10	mA	REG0=3FFh, OUT0=15V
Sink current capability (AMP1~5, 7~10)	looB	-	-	-30	mA	REG1~5, 7~10=1B5h OUT1~5, 7~10=15V
Sink current capability (AMP6)	looC	-	-	-60	mA	REG6=1B5h, OUT6=15V
Sink current capability (AMP11)	looD	-	-	-60	mA	REG11=048h, OUT11=2V
Source current capability (AMP0)	loiA	60	-	-	mA	REG0=3FFh, OUT0=13V
Source current capability (AMP1~5, 7~10)	loiB	30	-	-	mA	REG1~5, 7~10=1B5h OUT1~5, 7~10=0V
Source current capability (AMP6)	loiC	60	-	-	mA	REG6=1B5h, OUT6=0V
Source current capability (AMP11)	loiD	10	-	-	mA	REG11=048h, OUT11=0V
Load stability (OUT0)	ΔV -A	-	10	70	mV	Io=0mA~30mA OUT0=6V
Load stability (OUT1~5, 7~10)	ΔV -B	-	10	70	mV	Io=-15mA~15mA OUTx=6V
Load stability (OUT6)	ΔV -C	-	10	70	mV	Io=-15mA~15mA OUT6=6V
Load stability (OUT11)	ΔV -D	-	10	70	mV	Io=0mA~30mA OUT11=6V
OUT MAX. output voltage (OUT0)	VOH-A	VCC-0.2	VCC-0.1	-	V	Io=-30mA
OUT MAX. output voltage (OUT1~5, 7~10)	VOH-B	VCC-1.2	VCC-0.75	-	V	Io=-15mA
OUT MAX. output voltage (OUT6)	VOH-C	VCC-0.5	VCC-0.1	-	V	Io=-30mA
OUT MAX. output voltage (OUT11)	VOH-D	VCC-1.2	VCC-0.75	-	V	Io=-15mA
OUT MIN. output voltage (OUT0)	VOL-A	-	0.75	1.2	V	Io=15mA
OUT MIN. output voltage (OUT1~5, 7~10)	VOL-B	-	0.75	1.2	V	Io=15mA
OUT MIN. output voltage (OUT6)	VOL-C	-	0.1	0.5	V	Io=30mA
OUT MIN. output voltage (OUT11)	VOL-D	-	0.1	0.2	V	Io=30mA

● Electrical Characteristics (Unless otherwise specified, Ta=25°C, VDD=3.3V, VCC=15V, REFIN=3.5V)

PARAMETER	SYMBOL	LIMITS			UNIT	CONDITION
		MIN	TYP	MAX		
[VDAC]						
FB voltage	Vfb	1.237	1.25	1.263	V	
Input bias current	I _{fb}	1.2	0.1	1.2	μA	Vfb=1.3V
Current capability	I _o	10	50	-	mA	
[Gamma Amplifier]						
Slew rate (AMP0)	SR0	1	4	-	V/μsec	OUT0=No load
Slew rate (AMP1~5, 7~10)	SRX	1	4	-	V/μsec	OUT1~5, 7~10=No load
Slew rate (AMP6)	SR6	1	4	-	V/μsec	OUT6=No load
Slew rate (AMP11)	SR11	1	4	-	V/μsec	OUT11=No load
[DAC]						
Integral Non-linearity Error (INL)	LE	-2	-	2	LSB	00A ~ 3F5 is the allowance margin of error against the ideal linear.
Differential Non-linearity Error (DNL)	DLE	-2	-	2	LSB	00A ~ 3F5 is the allowance margin of error against the ideal increase of 1LSB.
Output voltage precision Thermal Characteristics 1	Vt1	-200	50	200	mV	Ta=-25°C~85°C
Output voltage precision Thermal Characteristics 2	Vt2	-100	30	100	mV	Ta=0°C~75°C
[Control Signal 1 SEL, EN, A0, A1, A2, SLAVE/AR, EN_AR]						
Inrush current	I _{ctl}	7	16.5	33	μA	V _{IN} =3.3V
Threshold voltage 1A	V _{TH1A}	0.8	-	1.7	V	
Threshold voltage 1B	V _{TH1B}	0.6	-	1.7	V	VDD=2.5V
[Control Signal 2 SDA, SCL]						
Threshold voltage 2A	V _{TH2A}	0.8	-	1.7	V	
Threshold voltage 2B	V _{TH2B}	0.6	-	1.7	V	VDD=2.5V
MIN. output voltage	V _{CL}	-	-	0.4	V	ISDA=3mA, ISCL=3mA
[Whole Device]						
VDD Power ON Reset Start-up voltage	V _{det1}	1.75	1.9	2.05	V	
REFIN UVLO voltage	V _{det2}	1.75	1.9	2.05	V	
SEL switching time *1	t _{SEL}	-	0.3	1.0	μsec	
Circuit current	ICC	-	6	-	mA	

○ This product is not designed for protection against radio active rays.

*1 SEL switching time timing is shown below.

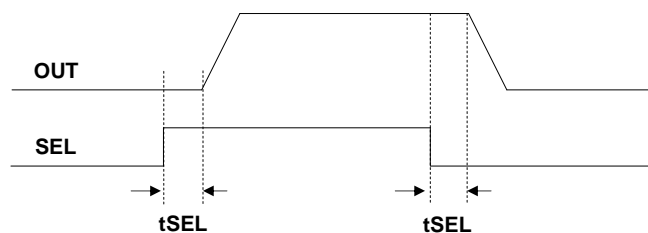
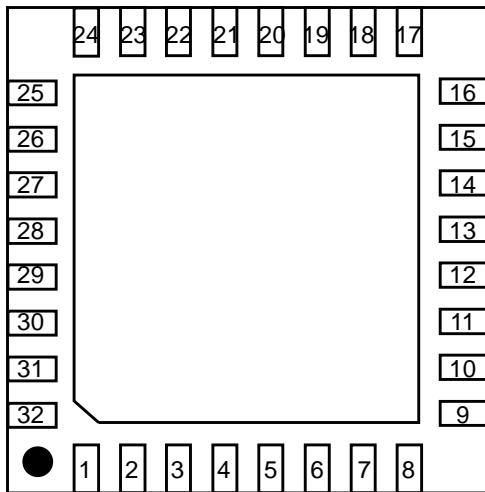

Fig.1 SEL switching time timing

● Pin Configuration (Top View)



● Block Diagram

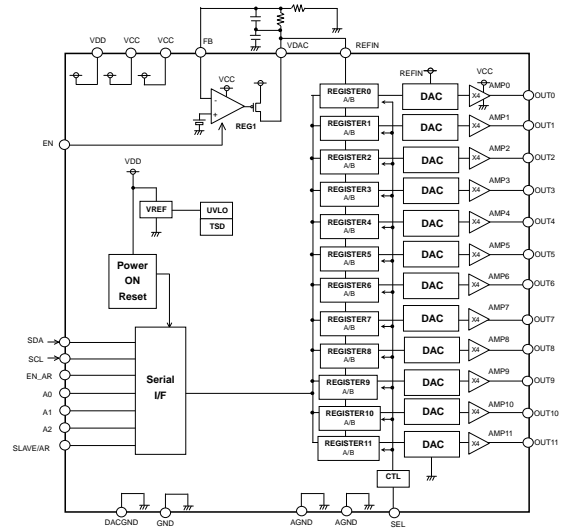

Fig.2 Pin Configuration & Block Diagram

● Pin Location and Function

PIN No.	PIN NAME	FUNCTION	PIN No.	PIN NAME	FUNCTION
1	GND	GND input	17	OUT9	Gamma output pin
2	A0	Device address switching pin	18	OUT8	Gamma output pin
3	A1	Word address switching pin	19	OUT7	Gamma output pin
4	A2	Word address switching pin	20	OUT6	Gamma output pin
5	SDA	Serial data input pin	21	OUT5	Gamma output pin
6	SCL	Serial clock input pin	22	OUT4	Gamma output pin
7	EN	VDAC enable pin	23	OUT3	Gamma output pin
8	EN_AR	Auto-read enable pin	24	OUT2	Gamma output pin
9	VDD	Logic power supply input	25	OUT1	Gamma output pin
10	SLAVE/AR	Slave / Auto-read switching pin	26	OUT0	Gamma output pin
11	SEL	REGISTER A/B select pin	27	N.C.	-
12	TEST	Pin for test mode	28	VCC	Power supply input
13	DACGND	GND input for DAC	29	N.C.	-
14	AGND	Buffer AMP GND input	30	REFIN	DAC reference voltage input pin
15	OUT11	Gamma output pin	31	VDAC	DAC voltage output
16	OUT10	Gamma output pin	32	FB	Feedback pin

*In normal use, please connect 12pin TEST pin to OPEN or GND.

● Operation of each block

• REG

This is a regulator block for setting a reference voltage of DAC.

VDAC has enable function so that if EN=Low, shut down is performed, or EN=High, settable VDAC voltage by FB voltage and external resistor. At this time, VDAC voltage < 4.5[V] (MAX. operating voltage) should be configured.

*With the VDAC pin is shorted to REFIN pin, please set VDAC voltage to meet the REFIN operating condition.

• DAC Control

The DAC LOGIC converts the 10bit digital signal read to the register to a voltage.

• Amp

Amp amplifies the voltage output from the DAC LOGIC by 4 times.

While Under Voltage Lock-Out (UVLO) circuit or Thermal Shut Down (TSD) circuit is operating, output goes into Hi-z.

• Power On Reset

When the digital power supply DVCC is activated, each IC generates a reset signal to initialize the serial I/F and each registers.

• VREF

This is a block to generate an inner reference voltage.

• TSD(Thermal Shut Down)

The TSD circuit turns output off when the chip temperature reaches or exceeds approximately 175°C in order to prevent thermal destruction or thermal runaway. When the chip returns to a specified temperature, the circuit resets.

The TSD circuit is designed only to protect the IC itself. Application thermal design should ensure operation of the IC below the junction temperature of approximately 150°C.

• Register

A serial signal (consisting of 10-bit gamma correction voltage values) input using the serial interface is held for each register address. Data is initialized by a reset signal generated during a Power On Reset.

Register is selectable by SEL pin.

When SEL=Low, REGISTER A is connected to DAC, and when SEL=High, REGISTER B is connected to DAC.

• Serial I/F

This is a 2-line serial (SDA, SCL) type I/F. It can set a gamma voltage and a Register address.

● Reference data

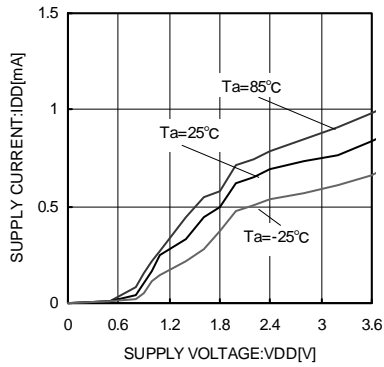

Fig.3 VDD circuit current

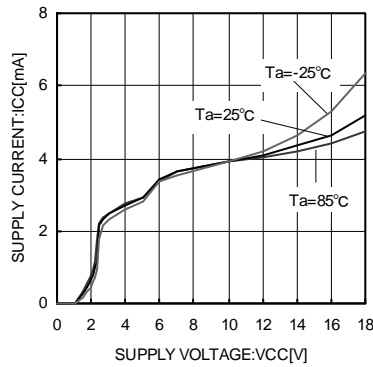

Fig.4 VCC circuit current

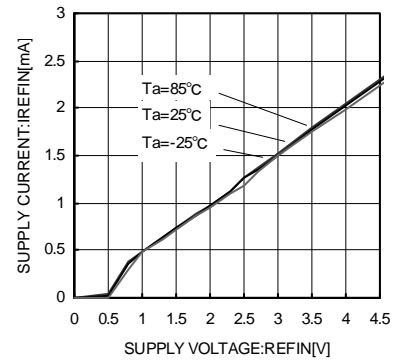

Fig.5 REFIN circuit current

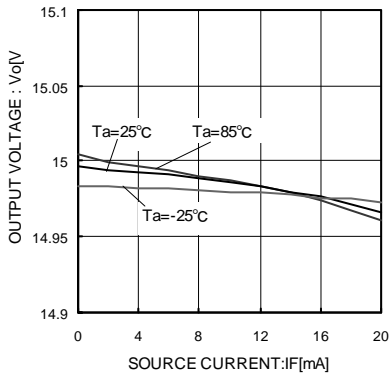

Fig.6 Output HIGH voltage (OUT0)

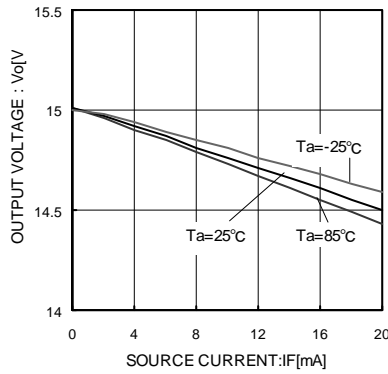

Fig.7 Output HIGH voltage (OUT1)

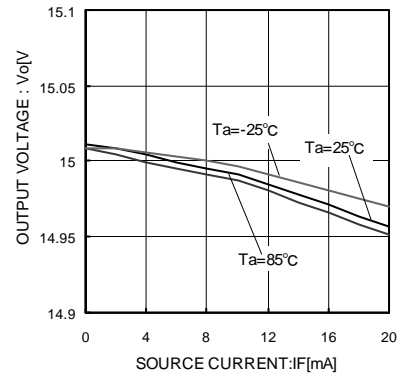

Fig.8 Output HIGH voltage (OUT6)

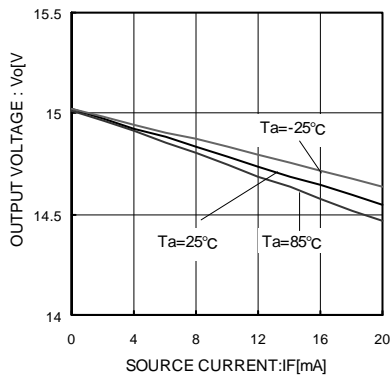

Fig.9 Output HIGH voltage (OUT11)

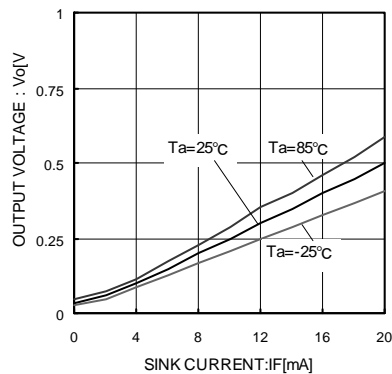

Fig.10 Output LOW voltage (OUT0)

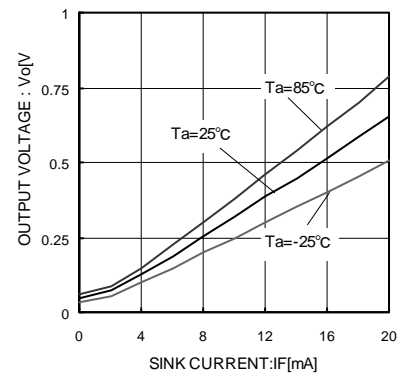

Fig.11 Output LOW voltage (OUT1)

●Reference data

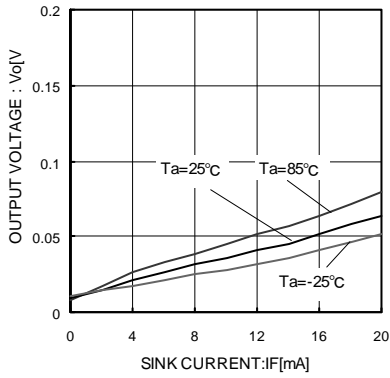

Fig.12 Output LOW voltage (OUT6)

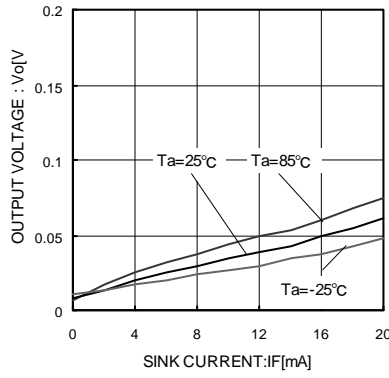

Fig.13 Output LOW voltage (OUT11)

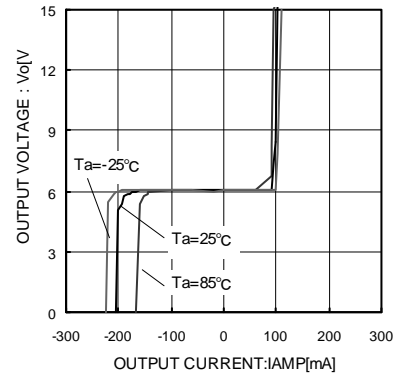

Fig.14 Output current capability (OUT0)

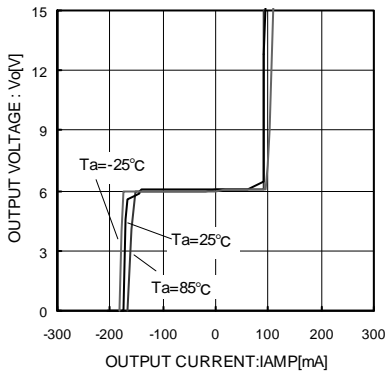

Fig.15 Output current capability (OUT1)

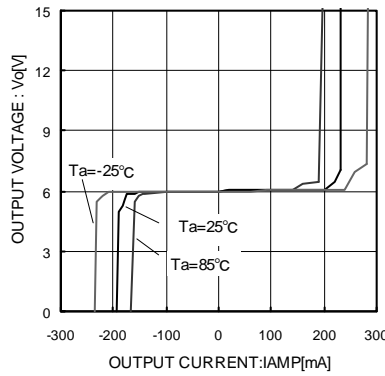

Fig.16 Output current capability (OUT6)

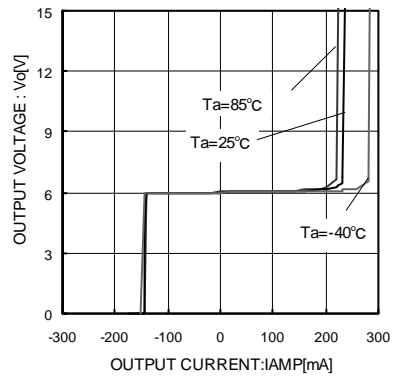

Fig.17 Output current capability (OUT11)

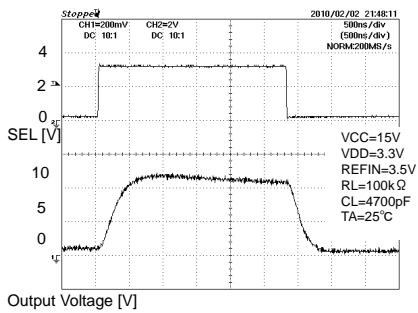

Fig.18 Slew rate waveform (High-Amplitude)

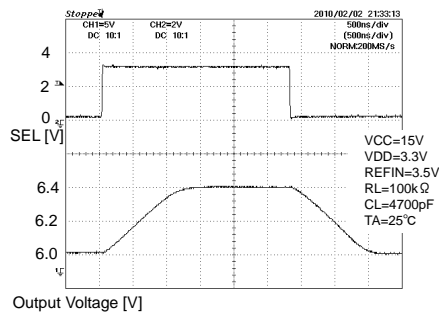

Fig.19 Slew rate waveform (Small signal)

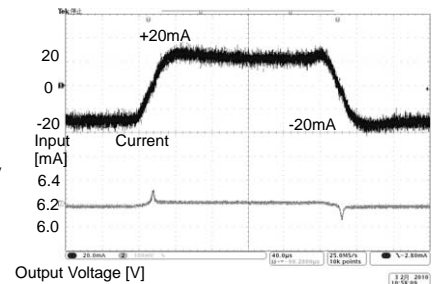
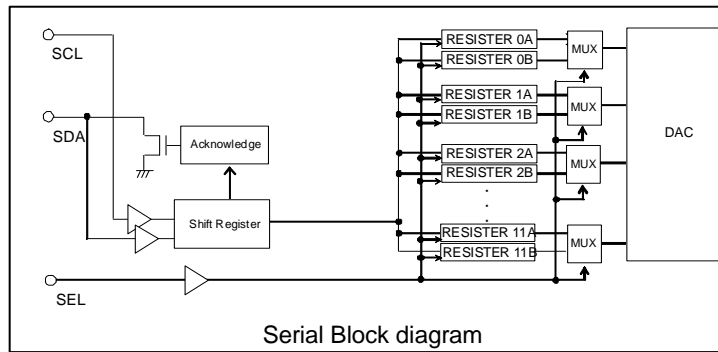

Fig.20 Load transient

●Serial communications

The serial data control block consists of a register that stores data from SDA and SCL, and a DAC circuit that receives the output from this register and provides adjusted voltages to other IC blocks.



●Output voltage setting mode

①Auto Read MODE

The auto-read function enables the I²C BUS I/F external EEPROM to be automatically read.

Automatic read from EEPROM will start when auto-read trigger signal is inputted.

I²C BUS timing is FAST-MODE of specified timing (P13).

EEPROM device address is 1010_00A. (A is a word address bit.)

A1 and A2 serves as the EEPROM word address setting pins.

When A1 and A2 are both set to Low, read access is available for word addresses 0 through 47 in EEPROM.

After data read to all Register, each output starts outputting synchronously. Until output start from VCC input, it outputs 0V.

A2	A1	RESISTER A		RESISTER B	
		READ START WORD ADDRESS	READ START WORD ADDRESS	READ END WORD ADDRESS	READ END WORD ADDRESS
L	L	0(000h)	23(017h)	24(018h)	47(02Fh)
L	H	128(080h)	151(094h)	152(095h)	175(0AFh)
H	L	256(100h)	279(117h)	280(118h)	303(12Fh)
H	H	361(169h)	384(180h)	405(195h)	428(1ACh)

MODE SETTING

- SLAVE/AR = High

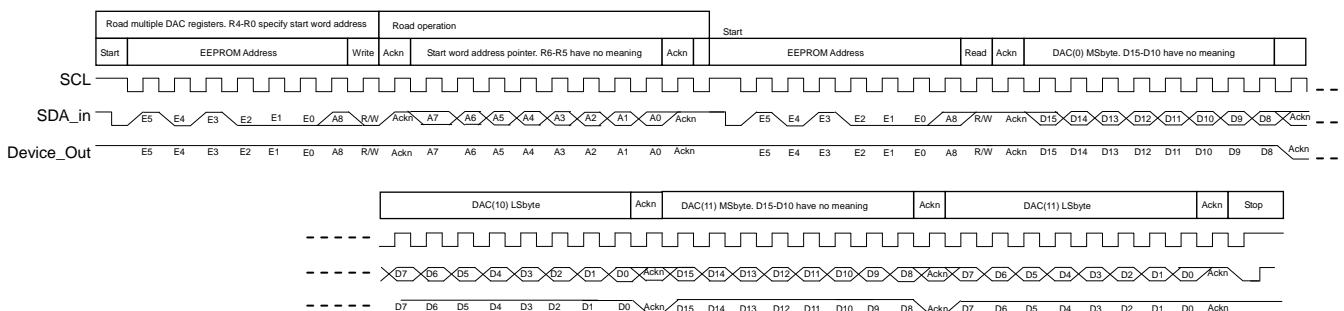

*1 Data writing to a Register is operated in order: Register0A~11A, 0B~11B.

*2 SLAVE/AR = High setting activates auto-read mode.

SLAVE signal is not accepted during auto-read waiting mode after VDD input.

After data reading completion by auto-read, it switches to SLAVE mode.

*3 Other command is rejected in auto-read operation.

*4 Auto-read mode is corresponded to EEPROM with 1Kbit, 2Kbit, 4Kbit.

< Explanation of Auto-read trigger signal >

(1) In case auto-read starts by VDD power supply input

Auto-read will start after Power ON Reset clearance.

Gamma output voltage outputs a voltage matching the register setting synchronously after VCC voltage and REFIN voltage input. (※)

The data reading time by auto-read is 3msec. Should maintain EN_AR=High during that time.

SETTING

- SLAVE/AR = High
- VDD input with the EN_AR pin is shorted to VDD pin

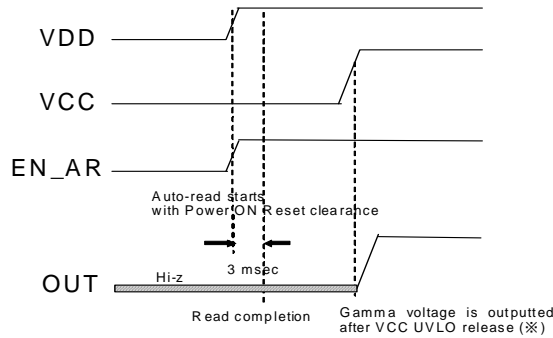

(※) The case VCC is inputted after read completion

(2) In case auto-read starts by EN_AR

Auto-read will start with EN_AR=High.

Auto-read timing can be set optionally at the timing with EN_AR=High.

Gamma output voltage outputs a voltage matching a Register setting synchronously after VCC voltage and REFIN voltage input

Data reading time by auto-read is 3msec. Should maintain EN_AR=High during that time.

SETTING

- SLAVE/AR = High
- EN_AR = Low ⇒ High

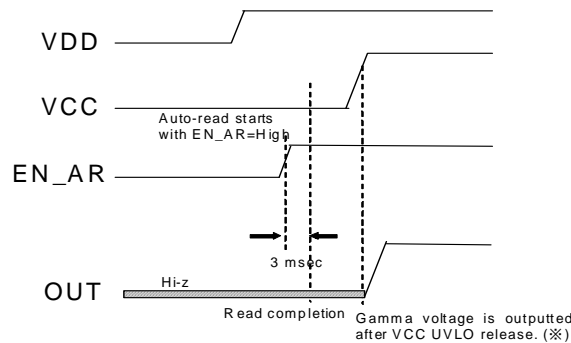

(※) The case VCC is inputted after read completion

- (3) In case auto-read starts by VCC power supply input
 Auto-read will start at the timing with Under Voltage Lock-Out release.
 Gamma output voltage outputs a voltage matching the register setting synchronously after auto-read completion.

SETTING

- SLAVE/AR = High
- EN_AR = Low

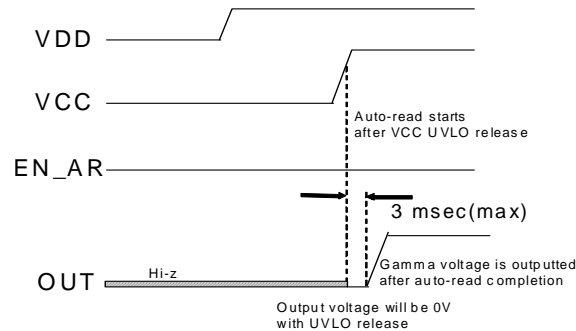

*Data reading time by auto-read is 3 msec(max).

*The auto-read starts by the VCC voltage input becomes effective only in the case of 1st auto-read operation after the VDD voltage input.

< About Data Refresh >

To perform reloading data "Data Refresh", having EN_AR switches Low to High enables auto-read operation again from EEPROM, and re-read the data. 10usec holding time is needed to determine EN_AR logic. Data reading time by auto-read is 3 msec. Should maintain EN_AR=High during that time.

<In case inputting EN_AR=Low during auto-read operation>

If inputting EN_AR=Low during auto-read operation, input from D15 to D0 is completed and write the inputted data to a register taken back ACK. When EN_AR=Low is determined, the half-way and the following reading data will be invalid. 10usec holding time is needed to determine EN_AR logic.

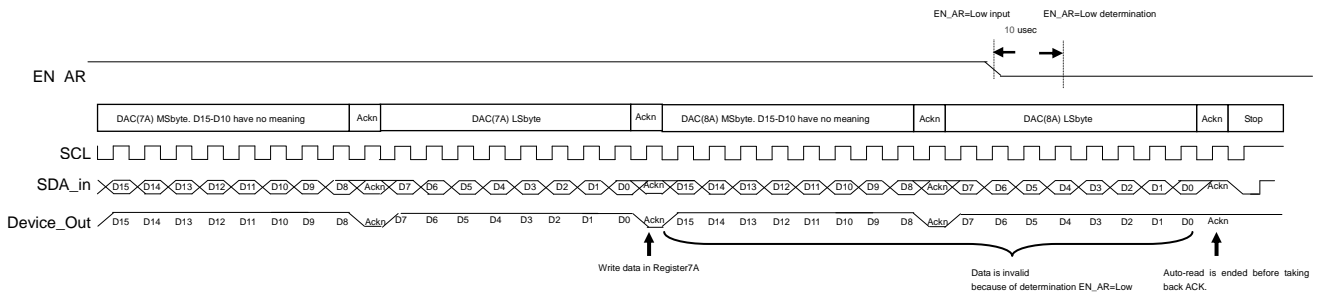

②SLAVE MODE

Write data in a specified register address through I²C BUS.

There are two writing modes from I²C BUS to Register: (i) Single mode (ii) Multi mode .

In Single mode, write data in one specified register.

In Multi mode, inputting multiple data from start address as specified register at 2nd Byte enables to write data in a row. Single mode or Multi mode can be set by having or not having STOP bit.

MODE SETTING

- SLAVE/AR = Low
- R/W = Low(1byte, 8th bit)

(i) Single mode timing chart

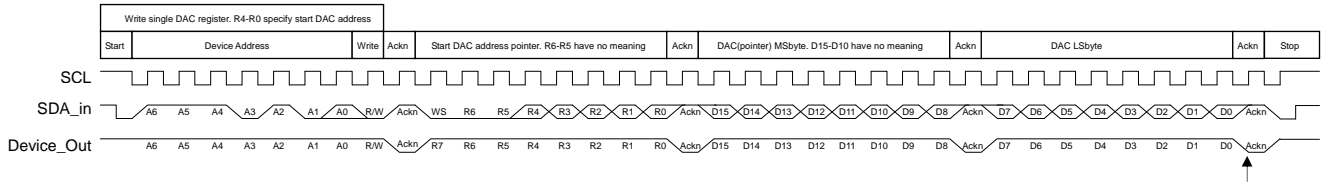

(ii) Multi mode timing chart

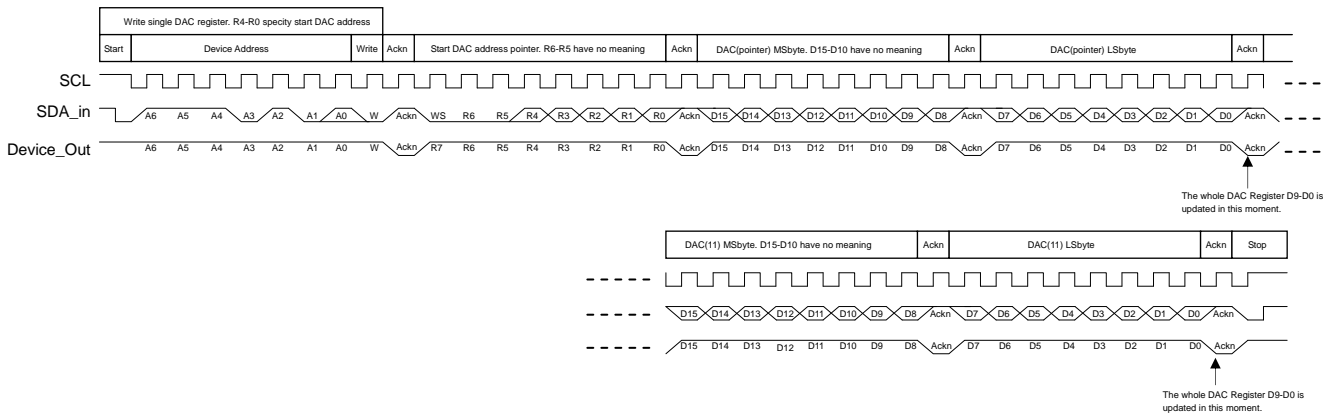

*Writing data to a Register is operating in order: Register0A~11A, 0B~11B.

●Double Register switching function

Switching High/Low by SEL pin enables switch to REGISTER A or REGISTER B.
At that time, 2.0usec (max) takes from SEL pin switching to output (OUT) change start.
When SEL=Low, REGISTER A is connected to DAC.
When SEL=High, REGISTER B is connected to DAC.

●REGISTER ADDRESS

Device address A6~A1 is specific to the IC. (A6~A0) =111010(A0).
A0 can be set externally. It is pulled down inside so that in open state, it is"0". If setting to "1", please connect to VDD.

REGISTER NAME	REGISTER ADDRESS					INITIAL VALUE	REGISTER NAME	REGISTER ADDRESS					INITIAL VALUE
	R4	R3	R2	R1	R0			R4	R3	R2	R1	R0	
Resister 0 A	0	0	0	0	0	000h	Resister 0 B	1	0	0	0	0	000h
Resister 1 A	0	0	0	0	1	000h	Resister 1 B	1	0	0	0	1	000h
Resister 2 A	0	0	0	1	0	000h	Resister 2 B	1	0	0	1	0	000h
Resister 3 A	0	0	0	1	1	000h	Resister 3 B	1	0	0	1	1	000h
Resister 4 A	0	0	1	0	0	000h	Resister 4 B	1	0	1	0	0	000h
Resister 5 A	0	0	1	0	1	000h	Resister 5 B	1	0	1	0	1	000h
Resister 6 A	0	0	1	1	0	000h	Resister 6 B	1	0	1	1	0	000h
Resister 7 A	0	0	1	1	1	000h	Resister 7 B	1	0	1	1	1	000h
Resister 8 A	0	1	0	0	0	000h	Resister 8 B	1	1	0	0	0	000h
Resister 9 A	0	1	0	0	1	000h	Resister 9 B	1	1	0	0	1	000h
Resister 10 A	0	1	0	1	0	000h	Resister 10 B	1	1	0	1	0	000h
Resister 11 A	0	1	0	1	1	000h	Resister 11 B	1	1	0	1	1	000h

As register address, use lower 5 bit(R4~R0) at 2nd byte. R6~R5 should be set to 0 as usual.

●Gamma output setting

Relation between gamma output voltage (OUT0~OUT11) and DAC setting value is shown in formula below (1). .

$$\text{Output voltage (OUT0~OUT11)} = \{(\text{DAC setting value}+1)/1024\} \times \text{REFIN} \times 4 \quad \cdot \cdot \cdot (1)$$

Output voltage characteristics are the electrical characteristics shown in Page.2 regardless the setting voltage.

●Power supply sequence

Activate the logic power supply VDD before the power supply VCC to prevent IC malfunctions due to undefined logic in the logic circuit. Input serial data after canceling the Power on Reset. When turning off the IC's power supplies, turn off VCC first and then VDD.

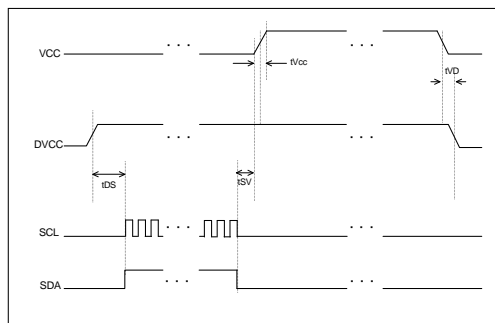

Power supply sequence diagram

●Power supply sequence specific value

Parameter	Symbol	LIMIT			Unit	Condition
		Min.	Typ.	Max.		
Serial input timing	tDS	100	-	-	us	
VCC input timing	tSV	-	10	-	us	
Power supply OFF timing	tVD	0	10	-	us	
VCC(REFIN) rising time	tVCC	3	-	-	ms	

● I2C timing

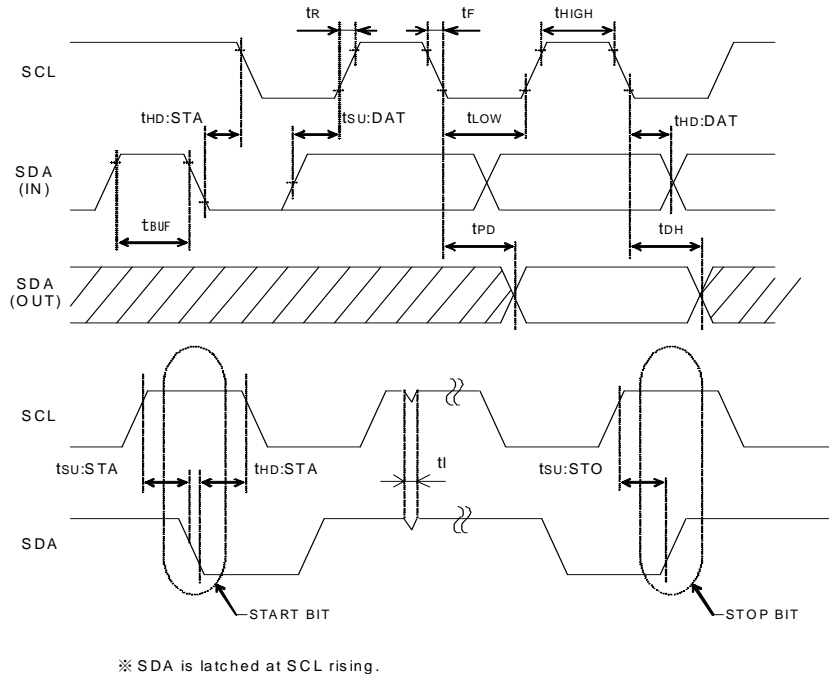
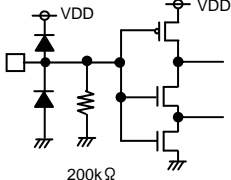
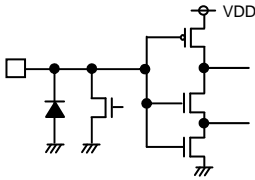
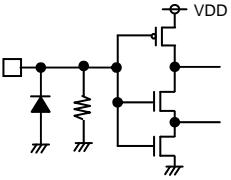
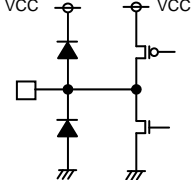
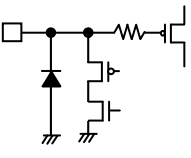
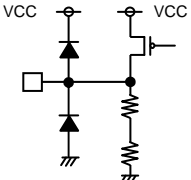
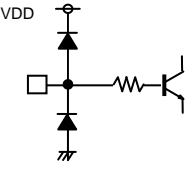

Fig.21 I2C timing

● Timing specification

Parameter	Symbol	STANDARD-MODE			FAST-MODE			Unit
		Min.	Typ.	Max.	Min.	Typ.	Max.	
Auto Read SCL frequency	fASCL	—	—	-	150	275	400	kHz
SCL frequency	fSCL	—	—	100	—	—	400	kHz
SCL "H" time	tHIGH	4.0	—	—	0.6	—	—	us
SCL "L" time	tLOW	4.7	—	—	1.2	—	—	us
Rising time	tR	—	—	1.0	—	—	0.3	us
Falling time	tF	—	—	0.3	—	—	0.3	us
Start condition Holding time	tHD:STA	4.0	—	—	0.6	—	—	us
Start condition Setting up time	tSU:STA	4.7	—	—	0.6	—	—	us
SDA holding time	tHD:DAT	200	—	—	100	—	—	ns
SDA set-up time	tSU:DAT	200	—	—	100	—	—	ns
Acknowledge delay time	tPD	—	—	0.9	—	—	0.9	us
Acknowledge hold time	tDH	—	0.1	—	—	0.1	—	us
Stop condition Setting up time	tSU:STO	4.7	—	—	0.6	—	—	us
BUS discharge time	tBUF	4.7	—	—	1.2	—	—	us
Noise spike width	tI	—	0.1	—	—	0.1	—	us

● I/O equivalent circuit

<p>2.A0, 3.A1, 4.A2, 10.SLAVE/AR, 12.TEST</p>	<p>5.SDA, 6.SCL</p>	<p>7.EN, 8.EN_AR, 11.SEL</p>
		
<p>15.OUT11, 16.OUT10, 17.OUT9, 18.OUT8 19.OUT7, 20.OUT6, 21.OUT5, 22.OUT4 23.OUT3, 24.OUT2, 25.OUT1, 26.OUT0</p>	<p>30.REFIN</p>	<p>31.VDAC</p>
		
<p>32.FB</p>		
		

●Operation Notes

1) Absolute maximum ratings

Use of the IC in excess of absolute maximum ratings such as the applied voltage or operating temperature range may result in IC damage. Assumptions should not be made regarding the state of the IC (short mode or open mode) when such damage is suffered. A physical safety measure such as a fuse should be implemented when use of the IC in a special mode where the absolute maximum ratings may be exceeded is anticipated.

2) GND potential

Ensure a minimum GND pin potential in all operating conditions.

3) Thermal design

Use a thermal design that allows for a sufficient margin in light of the power dissipation (P_d) in actual operating conditions.

4) Pin short and mistake fitting

Use caution when orienting and positioning the IC for mounting on printed circuit boards. Improper mounting may result in damage to the IC. Shorts between output pins or between output pins and the power supply and GND pins caused by the presence of a foreign object may result in damage to the IC.

5) Actions in strong magnetic field

Use caution when using the IC in the presence of a strong magnetic field as doing so may cause the IC to malfunction.

6) Testing on application boards

When testing the IC on an application board, connecting a capacitor to a pin with low impedance subjects the IC to stress. Always discharge capacitors after each process or step. Ground the IC during assembly steps as an antistatic measure, and use similar caution when transporting or storing the IC. Always turn the IC's power supply off before connecting it to or removing it from a jig or fixture during the inspection process.

7) Ground wiring patterns

When using both small signal and large current GND patterns, it is recommended to isolate the two ground patterns, placing a single ground point at the application's reference point so that the pattern wiring resistance and voltage variations caused by large currents do not cause variations in the small signal ground voltage. Be careful not to change the GND wiring patterns of any external components.

8) Regarding input pin of the IC

This monolithic IC contains P+ isolation and P substrate layers between adjacent elements in order to keep them isolated. P/N junctions are formed at the intersection of these P layers with the N layers of other elements to create a variety of parasitic elements.

For example, when the resistors and transistors are connected to the pins as shown below, a parasitic diode or a transistor operates by inverting the pin voltage and GND voltage.

The formation of parasitic elements as a result of the relationships of the potentials of different pins is an inevitable result of the IC's architecture. The operation of parasitic elements can cause interference with circuit operation as well as IC malfunction and damage. For these reasons, it is necessary to use caution so that the IC is not used in a way that will trigger the operation of parasitic elements, such as the application of voltages lower than the GND (P substrate) voltage to input and output pins.

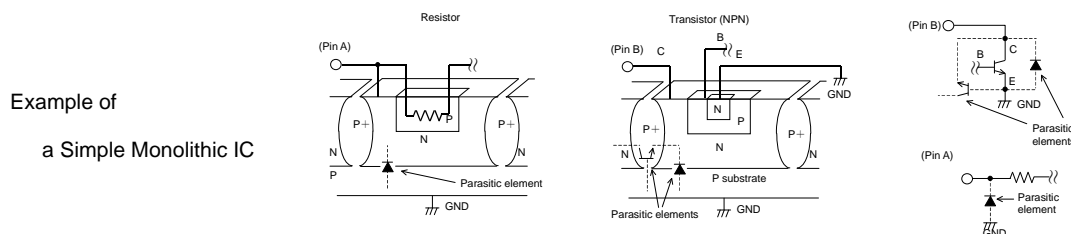

9) Steep change in VDD, VCC voltage, load

If the quite steep input voltage change happens, high current may rush in because of MOS at output transistor. In that case, please check and demonstrate on application boards to make variable slew rate keep the maximum rating $t_r \geq 1$ ms. Testing fully on application boards including transient change is recommended to decide the external component value.

10) TSD (Thermal shutdown) circuit

This IC incorporates a built-in TSD circuit for the protection from thermal destruction. The IC should be used within the specified power dissipation range. However, in the event that the IC continues to be operated in excess of its power dissipation limits, the attendant rise in the chip's junction temperature T_j will trigger the TSD circuit to turn off all output power elements. The circuit automatically resets once the junction temperature T_j drops.

Operation of the TSD circuit presumes that the IC's absolute maximum ratings have been exceeded. Application designs should never make use of the TSD circuit.

11) Testing on application boards

When testing the IC on an application board, connecting a capacitor to a pin with low impedance subjects the IC to stress. Always discharge capacitors after each process or step. Ground the IC during assembly steps as an antistatic measure, and use similar caution when transporting or storing the IC. Always turn the IC's power supply off before connecting it to or removing it from a jig or fixture during the inspection process.

12) Rush current

Because there are times when rush current flows instantaneously due to the lag in an order of power source putting on with IC where it has plural power sources, please pay attention to power source coupling capacity and power source and width of GND pattern wiring, winding.

Notice

Precaution on using ROHM Products

- Our Products are designed and manufactured for application in ordinary electronic equipments (such as AV equipment, OA equipment, telecommunication equipment, home electronic appliances, amusement equipment, etc.). If you intend to use our Products in devices requiring extremely high reliability (such as medical equipment ^(Note 1), transport equipment, traffic equipment, aircraft/spacecraft, nuclear power controllers, fuel controllers, car equipment including car accessories, safety devices, etc.) and whose malfunction or failure may cause loss of human life, bodily injury or serious damage to property ("Specific Applications"), please consult with the ROHM sales representative in advance. Unless otherwise agreed in writing by ROHM in advance, ROHM shall not be in any way responsible or liable for any damages, expenses or losses incurred by you or third parties arising from the use of any ROHM's Products for Specific Applications.

(Note1) Medical Equipment Classification of the Specific Applications

JAPAN	USA	EU	CHINA
CLASS III	CLASS III	CLASS II b	CLASS III
CLASS IV		CLASS III	

- ROHM designs and manufactures its Products subject to strict quality control system. However, semiconductor products can fail or malfunction at a certain rate. Please be sure to implement, at your own responsibilities, adequate safety measures including but not limited to fail-safe design against the physical injury, damage to any property, which a failure or malfunction of our Products may cause. The following are examples of safety measures:
 - Installation of protection circuits or other protective devices to improve system safety
 - Installation of redundant circuits to reduce the impact of single or multiple circuit failure
- Our Products are designed and manufactured for use under standard conditions and not under any special or extraordinary environments or conditions, as exemplified below. Accordingly, ROHM shall not be in any way responsible or liable for any damages, expenses or losses arising from the use of any ROHM's Products under any special or extraordinary environments or conditions. If you intend to use our Products under any special or extraordinary environments or conditions (as exemplified below), your independent verification and confirmation of product performance, reliability, etc. prior to use, must be necessary:
 - Use of our Products in any types of liquid, including water, oils, chemicals, and organic solvents
 - Use of our Products outdoors or in places where the Products are exposed to direct sunlight or dust
 - Use of our Products in places where the Products are exposed to sea wind or corrosive gases, including Cl₂, H₂S, NH₃, SO₂, and NO₂
 - Use of our Products in places where the Products are exposed to static electricity or electromagnetic waves
 - Use of our Products in proximity to heat-producing components, plastic cords, or other flammable items
 - Sealing or coating our Products with resin or other coating materials
 - Use of our Products without cleaning residue of flux (even if you use no-clean type fluxes, cleaning residue of flux is recommended); or Washing our Products by using water or water-soluble cleaning agents for cleaning residue after soldering
 - Use of the Products in places subject to dew condensation
- The Products are not subject to radiation-proof design.
- Please verify and confirm characteristics of the final or mounted products in using the Products.
- In particular, if a transient load (a large amount of load applied in a short period of time, such as pulse. is applied, confirmation of performance characteristics after on-board mounting is strongly recommended. Avoid applying power exceeding normal rated power; exceeding the power rating under steady-state loading condition may negatively affect product performance and reliability.
- De-rate Power Dissipation (Pd) depending on Ambient temperature (Ta). When used in sealed area, confirm the actual ambient temperature.
- Confirm that operation temperature is within the specified range described in the product specification.
- ROHM shall not be in any way responsible or liable for failure induced under deviant condition from what is defined in this document.

Precaution for Mounting / Circuit board design

- When a highly active halogenous (chlorine, bromine, etc.) flux is used, the residue of flux may negatively affect product performance and reliability.
- In principle, the reflow soldering method must be used; if flow soldering method is preferred, please consult with the ROHM representative in advance.

For details, please refer to ROHM Mounting specification

Precautions Regarding Application Examples and External Circuits

1. If change is made to the constant of an external circuit, please allow a sufficient margin considering variations of the characteristics of the Products and external components, including transient characteristics, as well as static characteristics.
2. You agree that application notes, reference designs, and associated data and information contained in this document are presented only as guidance for Products use. Therefore, in case you use such information, you are solely responsible for it and you must exercise your own independent verification and judgment in the use of such information contained in this document. ROHM shall not be in any way responsible or liable for any damages, expenses or losses incurred by you or third parties arising from the use of such information.

Precaution for Electrostatic

This Product is electrostatic sensitive product, which may be damaged due to electrostatic discharge. Please take proper caution in your manufacturing process and storage so that voltage exceeding the Products maximum rating will not be applied to Products. Please take special care under dry condition (e.g. Grounding of human body / equipment / solder iron, isolation from charged objects, setting of Ionizer, friction prevention and temperature / humidity control).

Precaution for Storage / Transportation

1. Product performance and soldered connections may deteriorate if the Products are stored in the places where:
 - [a] the Products are exposed to sea winds or corrosive gases, including Cl₂, H₂S, NH₃, SO₂, and NO₂
 - [b] the temperature or humidity exceeds those recommended by ROHM
 - [c] the Products are exposed to direct sunshine or condensation
 - [d] the Products are exposed to high Electrostatic
2. Even under ROHM recommended storage condition, solderability of products out of recommended storage time period may be degraded. It is strongly recommended to confirm solderability before using Products of which storage time is exceeding the recommended storage time period.
3. Store / transport cartons in the correct direction, which is indicated on a carton with a symbol. Otherwise bent leads may occur due to excessive stress applied when dropping of a carton.
4. Use Products within the specified time after opening a humidity barrier bag. Baking is required before using Products of which storage time is exceeding the recommended storage time period.

Precaution for Product Label

QR code printed on ROHM Products label is for ROHM's internal use only.

Precaution for Disposition

When disposing Products please dispose them properly using an authorized industry waste company.

Precaution for Foreign Exchange and Foreign Trade act

Since our Products might fall under controlled goods prescribed by the applicable foreign exchange and foreign trade act, please consult with ROHM representative in case of export.

Precaution Regarding Intellectual Property Rights

1. All information and data including but not limited to application example contained in this document is for reference only. ROHM does not warrant that foregoing information or data will not infringe any intellectual property rights or any other rights of any third party regarding such information or data. ROHM shall not be in any way responsible or liable for infringement of any intellectual property rights or other damages arising from use of such information or data.:
2. No license, expressly or implied, is granted hereby under any intellectual property rights or other rights of ROHM or any third parties with respect to the information contained in this document.

Other Precaution

1. This document may not be reprinted or reproduced, in whole or in part, without prior written consent of ROHM.
2. The Products may not be disassembled, converted, modified, reproduced or otherwise changed without prior written consent of ROHM.
3. In no event shall you use in any way whatsoever the Products and the related technical information contained in the Products or this document for any military purposes, including but not limited to, the development of mass-destruction weapons.
4. The proper names of companies or products described in this document are trademarks or registered trademarks of ROHM, its affiliated companies or third parties.

General Precaution

1. Before you use our Products, you are requested to carefully read this document and fully understand its contents. ROHM shall not be in any way responsible or liable for failure, malfunction or accident arising from the use of any ROHM's Products against warning, caution or note contained in this document.
2. All information contained in this document is current as of the issuing date and subject to change without any prior notice. Before purchasing or using ROHM's Products, please confirm the latest information with a ROHM sales representative.
3. The information contained in this document is provided on an "as is" basis and ROHM does not warrant that all information contained in this document is accurate and/or error-free. ROHM shall not be in any way responsible or liable for any damages, expenses or losses incurred by you or third parties resulting from inaccuracy or errors of or concerning such information.

Компания «Life Electronics» занимается поставками электронных компонентов импортного и отечественного производства от производителей и со складов крупных дистрибьюторов Европы, Америки и Азии.

С конца 2013 года компания активно расширяет линейку поставок компонентов по направлению коаксиальный кабель, кварцевые генераторы и конденсаторы (керамические, пленочные, электролитические), за счёт заключения дистрибьюторских договоров

Мы предлагаем:

- Конкурентоспособные цены и скидки постоянным клиентам.
- Специальные условия для постоянных клиентов.
- Подбор аналогов.
- Поставку компонентов в любых объемах, удовлетворяющих вашим потребностям.
- Приемлемые сроки поставки, возможна ускоренная поставка.
- Доставку товара в любую точку России и стран СНГ.
- Комплексную поставку.
- Работу по проектам и поставку образцов.
- Формирование склада под заказчика.
- Сертификаты соответствия на поставляемую продукцию (по желанию клиента).
- Тестирование поставляемой продукции.
- Поставку компонентов, требующих военную и космическую приемку.
- Входной контроль качества.
- Наличие сертификата ISO.

В составе нашей компании организован Конструкторский отдел, призванный помогать разработчикам, и инженерам.

Конструкторский отдел помогает осуществить:

- Регистрацию проекта у производителя компонентов.
- Техническую поддержку проекта.
- Защиту от снятия компонента с производства.
- Оценку стоимости проекта по компонентам.
- Изготовление тестовой платы монтаж и пусконаладочные работы.



Тел: +7 (812) 336 43 04 (многоканальный)

Email: org@lifeelectronics.ru