

# MAXIM

## Thermistor-to-Digital Converter

MAX6682

### General Description

The MAX6682 converts an external thermistor's temperature-dependent resistance directly into digital form. The thermistor and an external fixed resistor form a voltage-divider that is driven by the MAX6682's internal voltage reference. The MAX6682 measures the voltage across the external resistor and produces a 10-bit + sign output code dependent on that voltage.

The MAX6682 does not linearize the highly nonlinear transfer function of a typical negative temperature coefficient (NTC) thermistor, but it does provide linear output data over limited temperature ranges when used with an external resistor of the correct value. Over the 0° to +50°C temperature range, the MAX6682 produces output data that is scaled to 8LSBs/°C (for 0.125°C resolution), provided that the correct thermistor and external resistor values are used. Other temperature ranges can be easily accommodated, but do not necessarily yield data scaled to an even number of LSBs per degree.

The 3-wire SPI™-compatible interface can be readily connected to a variety of microcontrollers.

The MAX6682 is a read-only device, simplifying use in systems where only temperature data is required.

Power-management circuitry reduces the average thermistor current, minimizing self-heating. Between conversions, supply current is reduced to 21µA (typ). The internal voltage reference is shut down between measurements.

The MAX6682 is available in a small, 8-pin µMAX package and is specified over the -55°C to +125°C temperature range.

### Applications

HVAC  
Medical Devices  
Battery Packs/Chargers  
Home Appliances

**Pin Configuration appears at end of data sheet.**

*SPI is a trademark of Motorola, Inc.*

### Features

- ◆ Converts Thermistor Temperature to Digital Data
- ◆ Low Average Thermistor Current Minimizes Self-Heating Errors
- ◆ Low Supply Current, 21µA (typ) Including 10kΩ Thermistor Current
- ◆ Internal Voltage Reference Isolates Thermistor from Power-Supply Noise
- ◆ 10-Bit Resolution
- ◆ Accommodates Any Thermistor Temperature Range
- ◆ Output Data Scaled for Direct Temperature Readings from 0°C to +50°C
- ◆ Simple SPI-Compatible Interface
- ◆ Small, 8-Pin µMAX Package

### Ordering Information

PART	TEMP RANGE	PIN-PACKAGE
MAX6682MUA	-55°C to +125°C	8 µMAX

### Typical Operating Circuit

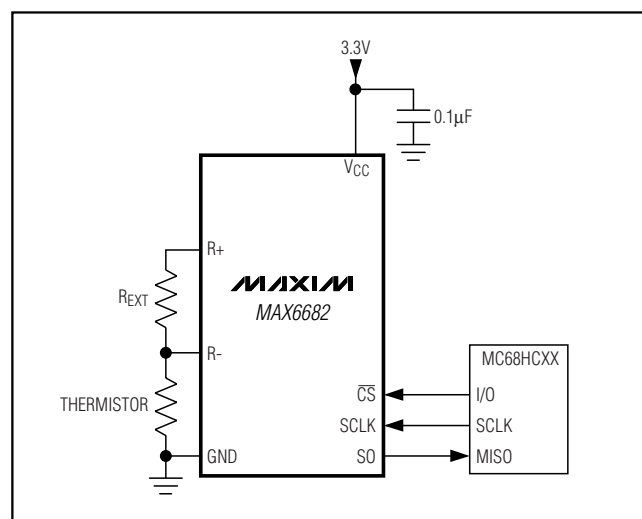

MAXIM

Maxim Integrated Products 1

**For pricing, delivery, and ordering information, please contact Maxim/Dallas Direct! at 1-888-629-4642, or visit Maxim's website at [www.maxim-ic.com](http://www.maxim-ic.com).**

# Thermistor-to-Digital Converter

## ABSOLUTE MAXIMUM RATINGS

Supply Voltage (V <sub>CC</sub> to GND)	-0.3V to +6V	Continuous Power Dissipation (T <sub>A</sub> = +70°C)	
SO, SCK, $\overline{\text{CS}}$ , R-, R+ to GND	-0.3V to (V <sub>CC</sub> + 0.3V)	8-Pin $\mu$ MAX (derate 4.1mW/°C above +70°C)	328mW
R+ Current	$\pm 20\text{mA}$	Operating Temperature Range	
R- Current	$\pm 1\text{mA}$	(T <sub>MIN</sub> to T <sub>MAX</sub> )	-55°C to +125°C
SCK, $\overline{\text{CS}}$ , SO Current	-1mA to +50mA	Storage Temperature Range	-65°C to +150°C
ESD Protection (Human Body Model)	$\pm 2000\text{V}$	Junction Temperature	+150°C

Stresses beyond those listed under "Absolute Maximum Ratings" may cause permanent damage to the device. These are stress ratings only, and functional operation of the device at these or any other conditions beyond those indicated in the operational sections of the specifications is not implied. Exposure to absolute maximum rating conditions for extended periods may affect device reliability.

## ELECTRICAL CHARACTERISTICS

(V<sub>CC</sub> = 3V to 5.5V, T<sub>A</sub> = -55°C to +125°C, unless otherwise noted. Typical values are specified at V<sub>CC</sub> = 3.3V and T<sub>A</sub> = +25°C.) (Note 1)

PARAMETER	SYMBOL	CONDITIONS	MIN	TYP	MAX	UNITS
Supply Voltage	V <sub>CC</sub>		3.0		5.5	V
ADC Total Unadjusted Error	TUE	DOUT = $768.935 \times (V_{\text{REXT}}/V_{\text{R+}}) - 134.0923$ ; V <sub>IN</sub> > 0.1V <sub>REF</sub>	-3		+3	LSB
ADC Conversion Time	t <sub>CONV</sub>			64	80	ms
R- Input Impedance	Z <sub>IN</sub>		1			M $\Omega$
R- Leakage Current				1	50	nA
Conversion Rate				0.5		Hz
Reference Voltage Output	V <sub>REF</sub>	I <sub>LOAD</sub> = 1mA	1.10	1.22	1.40	V
Reference Load Regulation		0 < I <sub>LOAD</sub> < 2mA	0		0.1	%/mA
Reference Supply Regulation				0.7		mV/V
Conversion Supply Current	I <sub>C</sub>	During conversion, no load		220	300	$\mu\text{A}$
Average Supply Current	I <sub>A</sub>	0.5 conversions/s, no load		17	29	$\mu\text{A}$
Standby Current	I <sub>S</sub>	$\overline{\text{CS}}$ low, SCK inactive		3	7	$\mu\text{A}$
Idle Current	I <sub>ID</sub>	$\overline{\text{CS}}$ high, analog circuits off		10	17	$\mu\text{A}$
<b>SERIAL INTERFACE</b>						
Input Low Voltage	V <sub>IL</sub>				0.2 x V <sub>CC</sub>	V
Input High Voltage	V <sub>IH</sub>		0.8 x V <sub>CC</sub>			V
Input Leakage Current	I <sub>LEAK</sub>	V <sub>IN</sub> = GND or V <sub>CC</sub>			1	$\mu\text{A}$
Output High Voltage	V <sub>OH</sub>	I <sub>SOURCE</sub> = 1.6mA	V <sub>CC</sub> - 0.4			V
Output Low Voltage	V <sub>OL</sub>	I <sub>SINK</sub> = 1.6mA			0.4	V

# Thermistor-to-Digital Converter

## TIMING CHARACTERISTICS

( $V_{CC} = 3V$  to  $5.5V$ ,  $T_A = T_{MIN}$  to  $T_{MAX}$ , unless otherwise noted. Typical values are specified at  $V_{CC} = 3.3V$  and  $T_A = +25^\circ C$ .) (Note 2)

PARAMETER	SYMBOL	CONDITIONS	MIN	TYP	MAX	UNITS
<b>SERIAL INTERFACE TIMING</b> (Figures 5 and 6)						
Serial Clock Frequency	fSCL				5	MHz
SCK Pulse High Width	tCH		50			ns
SCK Pulse Low Width	tCL		50			ns
CS Fall to SCK Rise	tCSS		35			ns
CS Fall to Output Data Valid	tDV	$C_L = 10pF$			35	ns
SCK Fall to Output Data Valid	tDO	$C_L = 10pF$			35	ns
CS Rise to Output High-Z	tTR	$C_L = 10pF$			25	ns
SCK Fall to Output High-Z	tHIZ	$C_L = 10pF$			35	ns
CS Pulse Width	tCSW		75			ns

**Note 1:** All specifications are 100% tested at  $T_A = +25^\circ C$ . Specification limits over temperature are guaranteed by design, not production tested.

**Note 2:** Guaranteed by design.

## Typical Operating Characteristics

( $V_{CC} = 5V$ , thermistor = 10k nominal,  $R_{EXT} = 7680\Omega$ ,  $T_A = +25^\circ C$ , unless otherwise noted.)

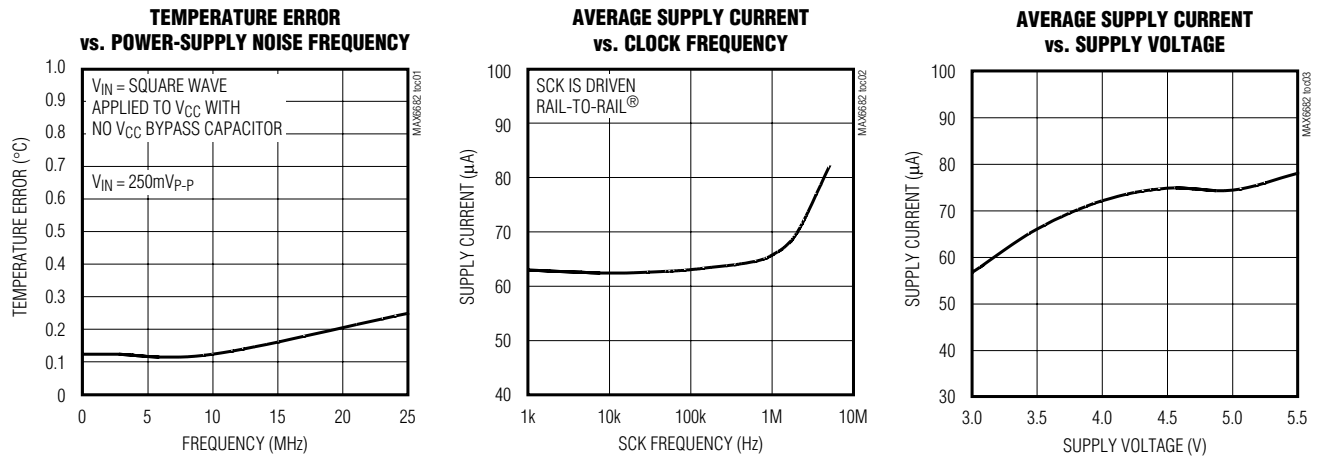

Rail-to-Rail is a registered trademark of Nippon Motorola, Ltd.

# Thermistor-to-Digital Converter

## Pin Description

PIN	NAME	FUNCTION
1	I.C.	Internally Connected. Connect to GND or leave unconnected.
2	R+	Reference Voltage Output. External resistor positive input.
3	R-	External Resistor Negative Input. Connect R- to the junction of the external resistor and the thermistor.
4	GND	Ground. Ground connection for MAX6682 and ground return for external thermistor.
5	$\overline{CS}$	Chip Select. Drive $\overline{CS}$ low to enable the serial interface.
6	SO	Serial Data Output
7	SCK	Serial Clock Input
8	V <sub>CC</sub>	Positive Supply. Bypass V <sub>CC</sub> to GND with a 0.1μF capacitor.

## Detailed Description

The MAX6682 is a sophisticated interface circuit that energizes a low-cost thermistor and converts its temperature-dependent resistance to 10-bit digital data. The MAX6682 powers the thermistor only when a measurement is being made; the power dissipated in the thermistor is minimized. This virtually eliminates self-heating, a major component of thermistor error. The simple serial interface is compatible with common microcontrollers.

### Temperature Conversion

The MAX6682 converts the voltage drop across the resistor R<sub>EXT</sub> to a digital output using an internal 10-bit ADC. By measuring the voltage across R<sub>EXT</sub>, the output code is directly related to temperature when using an NTC thermistor.

Although the relationship between a thermistor's resistance and its temperature is very nonlinear, the voltage across R<sub>EXT</sub> is reasonably linear over a limited temperature range, provided that R<sub>EXT</sub> is chosen properly. For example, over a +10°C to +40°C range, the relationship between the voltage across R<sub>EXT</sub> and temperature is linear to within approximately 0.2°C. Wider temperature ranges result in larger errors.

The digital output is available as a 10-bit + sign word. The relationship between the 11-bit digital word and the voltage across R<sub>EXT</sub> (normalized to V<sub>R+</sub>) is given by:

$$D_{OUT} = \frac{\left( \frac{V_{REXT}}{V_{R+}} - 0.174387 \right) \times 8}{0.010404}$$

where V<sub>REXT</sub>/V<sub>R+</sub> is the voltage across R<sub>EXT</sub> normalized to the value of V<sub>R+</sub>.

Table 1 shows the relationship between the voltage across R<sub>EXT</sub> and the MAX6682's digital output code. It also shows the temperature that would produce the listed value of V<sub>REXT</sub> when a standard thermistor is used in conjunction with R<sub>EXT</sub> = 7680Ω. The MAX6682 produces output codes scaled to the actual temperature when used with the standard thermistor and R<sub>EXT</sub> = 7680Ω over the +10°C to +40°C temperature range. Under these conditions, the nominal accuracy is about 0.2°C between +10° and +40°C, and about 1.5°C from 0°C to +50°C. In Table 1, the 3LSBs of the output code represent fractional temperatures. The LSB has a value of 0.125°C.

All table entries assume no errors in the values of R<sub>EXT</sub> or the thermistor resistance. Table 1 also assumes the use of one of the following standard thermistors: Betatherm 10K3A1, Dale 1M1002, or Thermometrics C100Y103J. These thermistors have a nominal resistance of 10kΩ at +25°C and very similar temperature-to-resistance functions. They give the results shown in Table 1.

Different temperature ranges can be accommodated as well using different values of R<sub>EXT</sub> (see *Choosing the External Resistor*). The MAX6682 works with thermistors other than the ones listed above, but the transfer functions vary somewhat.

## Applications Information

### Thermistors and Thermistor Selection

NTC thermistors are resistive temperature sensors whose resistance decreases with increasing temperature. They are available in a wide variety of packages that are useful in difficult applications such as measurement of air or liquid temperature. Some can operate over temperature ranges beyond that of most ICs. The relationship between temperature and resistance in an

# Thermistor-to-Digital Converter

**MAX6682**

**Table 1. Temperature vs. Digital Output for Standard Thermistor with  $R_{EXT} = 7680\Omega$**

THERMISTOR TEMPERATURE (°C)	$V_{R_{EXT}}$ (mV) WITH STANDARD THERMISTOR AND $R_{EXT} = 7680\Omega^*$	DECIMAL VALUE OF $D_{OUT}$ (1LSB = $0.125^\circ\text{C}$ )	$D_{OUT}$
+60.000	921.6	+55.875	001 1011 1111
+50.000	830.6	+48.625	001 1000 0101
+40.000	720.5	+40.000	001 0100 0000
+30.000	595.4	+30.125	000 1111 0001
+25.000	530.1	+25.000	000 1100 1000
+20.000	464.4	+19.875	000 1001 1111
+10.000	339.7	+10.000	000 0101 0000
0	232.3	+1.500	000 0000 1100
-0.725	225.5	+1.000	000 0000 1000
-2.000	213.6	0.125	000 0000 0001
-5.000	187.4	-2.000	111 1111 0000

\*Assumes  $V_{R+} = 1.220V$ .

NTC thermistor is very nonlinear and can be described by the following approximation:

$$1/T = A + B \ln R + C(\ln R)^3$$

where T is absolute temperature, R is the thermistor's resistance, and A, B, and C are coefficients that vary with manufacturer and material characteristics. The general shape of the curve is shown in Figure 1.

The highly nonlinear relationship between temperature and resistance in an NTC thermistor makes it somewhat more difficult to use than a digital-output temperature

sensor IC, for example. However, by connecting the thermistor in series with a properly chosen resistor and using the MAX6682 to measure the voltage across the resistor, a reasonably linear transfer function can be obtained over a limited temperature range. Errors decrease for smaller temperature ranges.

Figures 2 and 3 show typical thermistor nonlinearity curves for a standard thermistor in conjunction with series resistors chosen to optimize linearity over two different temperature ranges:  $+10^\circ\text{C}$  to  $+40^\circ\text{C}$  and  $0^\circ\text{C}$  to  $+70^\circ\text{C}$ .

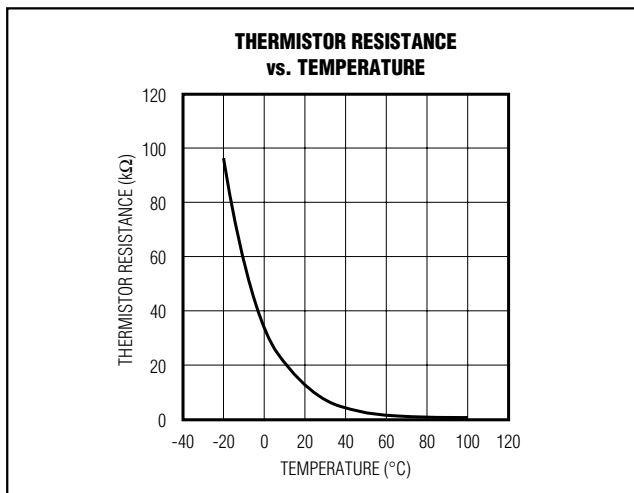

Figure 1. Thermistor Resistance vs. Temperature

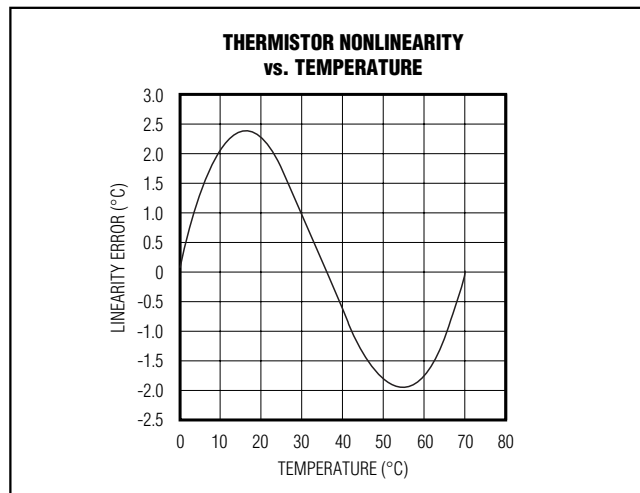

Figure 2. Thermistor Nonlinearity vs. Temperature for a Standard Thermistor from  $0^\circ\text{C}$  to  $+70^\circ\text{C}$

# Thermistor-to-Digital Converter

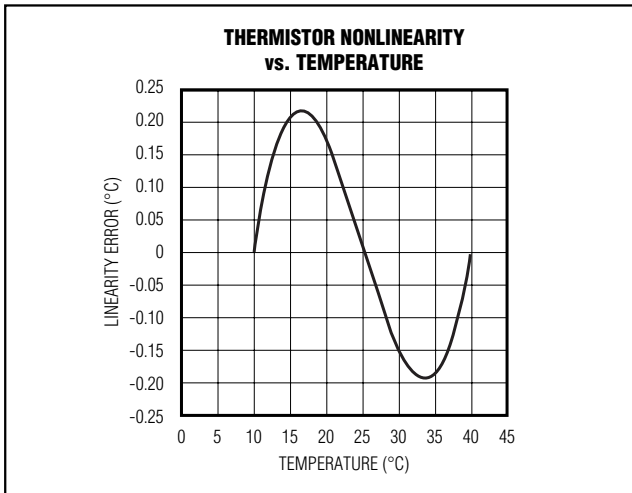

Figure 3. Thermistor Nonlinearity vs. Temperature for a Standard Thermistor from +10°C to +40°C

10-BIT TEMPERATURE READING											
Bit	10	9	8	7	6	5	4	3	2	1	0
	MSB (Sign)										LSB

Figure 4. SO Output

NTC thermistors are often described by the resistance at +25°C. Therefore, a 10kΩ thermistor has a resistance of 10kΩ at +25°C. When choosing a thermistor, ensure that the thermistor's minimum resistance (which occurs at the maximum expected operating temperature) in series with R<sub>EXT</sub> does not cause the voltage reference output current to exceed about 1mA. Some standard 10kΩ thermistors with similar characteristics are listed in Table 2. When used with one of these thermistors and the recommended series resistor, the MAX6682 provides output data scaled in °C over the +10°C to +40°C temperature range.

### Choosing the External Resistor

Choose R<sub>EXT</sub> to minimize nonlinearity errors from the thermistor:

- 1) Decide on the temperature range of interest (for example 0°C to +70°C).
- 2) Find the thermistor values at the limits of the temperature range. R<sub>MIN</sub> is the minimum thermistor value (at the maximum temperature) and R<sub>MAX</sub> is the maximum thermistor value (at the minimum temperature). Also find R<sub>MID</sub>, the thermistor resistance

in the middle of the temperature range (+35°C for the 0°C to +70°C range).

- 3) Find R<sub>EXT</sub> using the equation below:

$$R_{EXT} = \frac{R_{MID}(R_{MIN} + R_{MAX}) - 2R_{MIN}R_{MAX}}{R_{MIN} + R_{MAX} - 2R_{MID}}$$

Table 3 shows nominal output data for several temperatures when R<sub>EXT</sub> has been chosen according to the equation above for a temperature range of 0°C to +70°C. The output data is not conveniently scaled to the actual temperature over this range, but the linearity is better than 2.4°C over the 0°C to +70°C range (Figure 2). The temperature weighting over this range is 0.14925°C/LSB.

### Serial Interface

The *Typical Application Circuit* shows the MAX6682 interfaced with a microcontroller. In this example, the MAX6682 processes the reading from R<sub>EXT</sub> and transmits the data through an SPI-compatible interface. Force  $\overline{CS}$  low and apply a clock signal at SCK to read the results at SO. Forcing  $\overline{CS}$  low immediately stops any conversion in process. Initiate a new conversion by forcing  $\overline{CS}$  high.

Force  $\overline{CS}$  low to output the first bit on the SO pin. A complete read requires 11 clock cycles. Read the 11 output bits on the rising edge of the clock, if the first bit D10 is the sign bit. Bits D10–D0 contain the converted temperature in the order of MSB to LSB.

After the 11th clock cycle, SO goes to a high-impedance state. SO remains high impedance until  $\overline{CS}$  is pulsed high and brought back low. Figure 4 is the SO output.

### Power-Supply Considerations

The MAX6682 accuracy is relatively unaffected by power-supply coupled noise. In most applications, bypass V<sub>CC</sub> to GND by placing a 0.1μF ceramic bypass capacitor close to the supply pin of the devices.

### Thermal Considerations

Self-heating degrades the temperature measurement accuracy of thermistors. The amount of self-heating depends on the power dissipated in the thermistor and the dissipation constant of the thermistor. Dissipation constants depend on the thermistor's package and can vary considerably.

A typical thermistor might have a dissipation constant equal to 1mW/°C. For every mW the thermistor dissipates, its temperature rises by 1°C. For example, con-

# Thermistor-to-Digital Converter

**MAX6682**

sider a 10kΩ (at +25°C) NTC thermistor in series with a 5110Ω resistor operating at +40°C with a constant 5V bias. If it is one of the standard thermistors in Table 2, its resistance is 5325Ω at this temperature. The power dissipated in the thermistor is:

$$(5)^2(5325) / (5325 + 5110)^2 = 1.22\text{mW}$$

This thermistor would therefore have a self-heating error at +40°C of 1.22°C. Because the MAX6682 uses a small reference voltage and energizes the thermistor less than 2% of the time, the self-heating of the thermistor under the same conditions when used with the MAX6682 is only:

$$(1.22)^2(5325)(0.02) / (5325 + 5110)^2 \\ = 1.46\mu\text{W}, \text{ or only about } 0.0015^\circ \text{ (self-heating error)}$$

**Table 2. Standard Thermistors**

MANUFACTURER	PART	WEBSITE
Betatherm	10K3A1	www.betatherm.com
Dale	1M1002	www.vishay.com/brands/dale/main.html
Thermometrics	C100Y103J	www.thermometrics.com

**Table 3. Temperature vs. Digital Output for Standard Thermistor with R<sub>EXT</sub> = 5110Ω**

THERMISTOR TEMPERATURE (°C)	V <sub>R<sub>EXT</sub></sub> (mV) WITH STANDARD THERMISTOR AND R <sub>EXT</sub> = 5110Ω*	DECIMAL VALUE OF D <sub>OUT</sub> (USING 1LSB = 0.125°C)	D <sub>OUT</sub>
+75.000	946.0	57.75	001 1100 1110
+70.000	908.6	54.875	001 1011 0111
+60.000	820.6	47.875	001 0111 1111
+50.000	715.7	39.625	001 0011 1101
+40.000	597.4	30.25	000 1111 0010
+30.000	473.5	20.5	000 1010 0100
+25.000	412.6	15.750	000 0111 1110
+20.000	354.1	11.125	000 0101 1001
+10.000	249.2	2.875	000 0001 0111
0	165.1	-3.750	111 1110 0010
-5.000	131.5	-6.375	111 1100 1101

\*Assumes V<sub>R+</sub> = 1.220V.

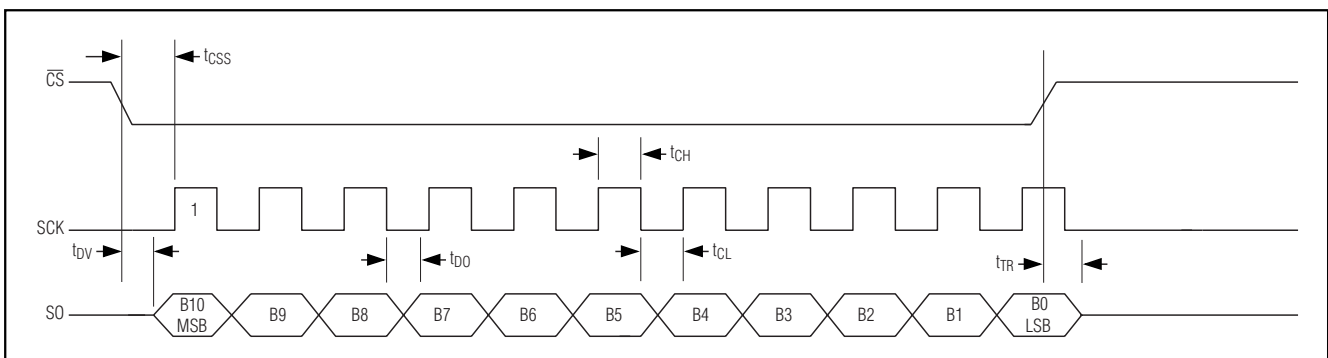

Figure 5. Serial Interface Timing

# Thermistor-to-Digital Converter

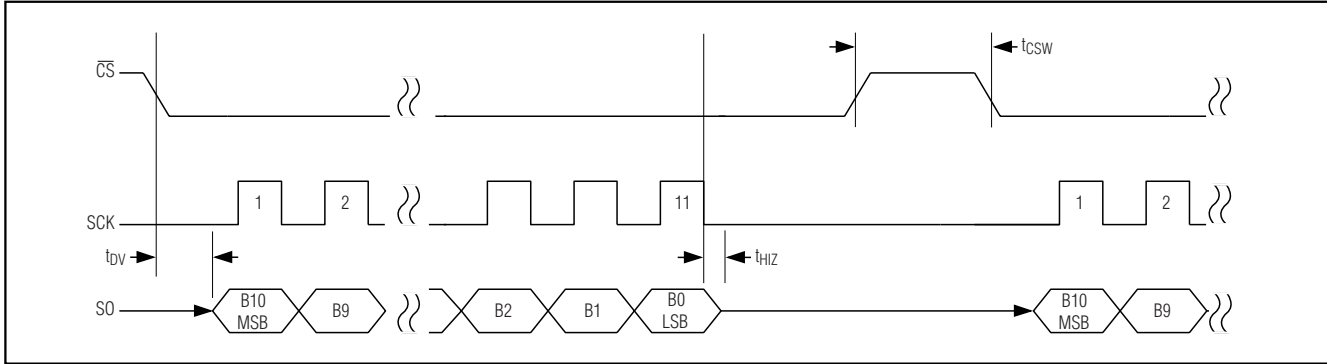
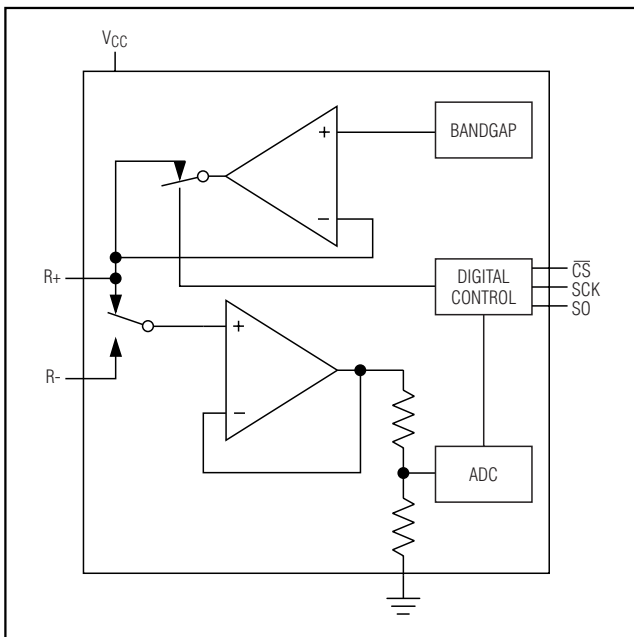
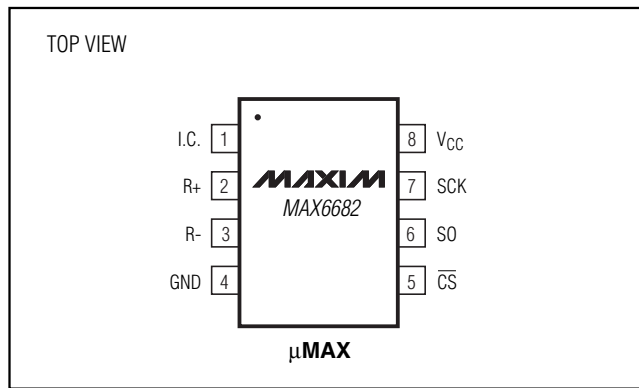

Figure 6. Serial Interface Timing 2

## Functional Diagram



## Pin Configuration



## Chip Information

TRANSISTOR COUNT: 4909  
PROCESS: BiCMOS



# Thermistor-to-Digital Converter

## Package Information

**MAX6682**

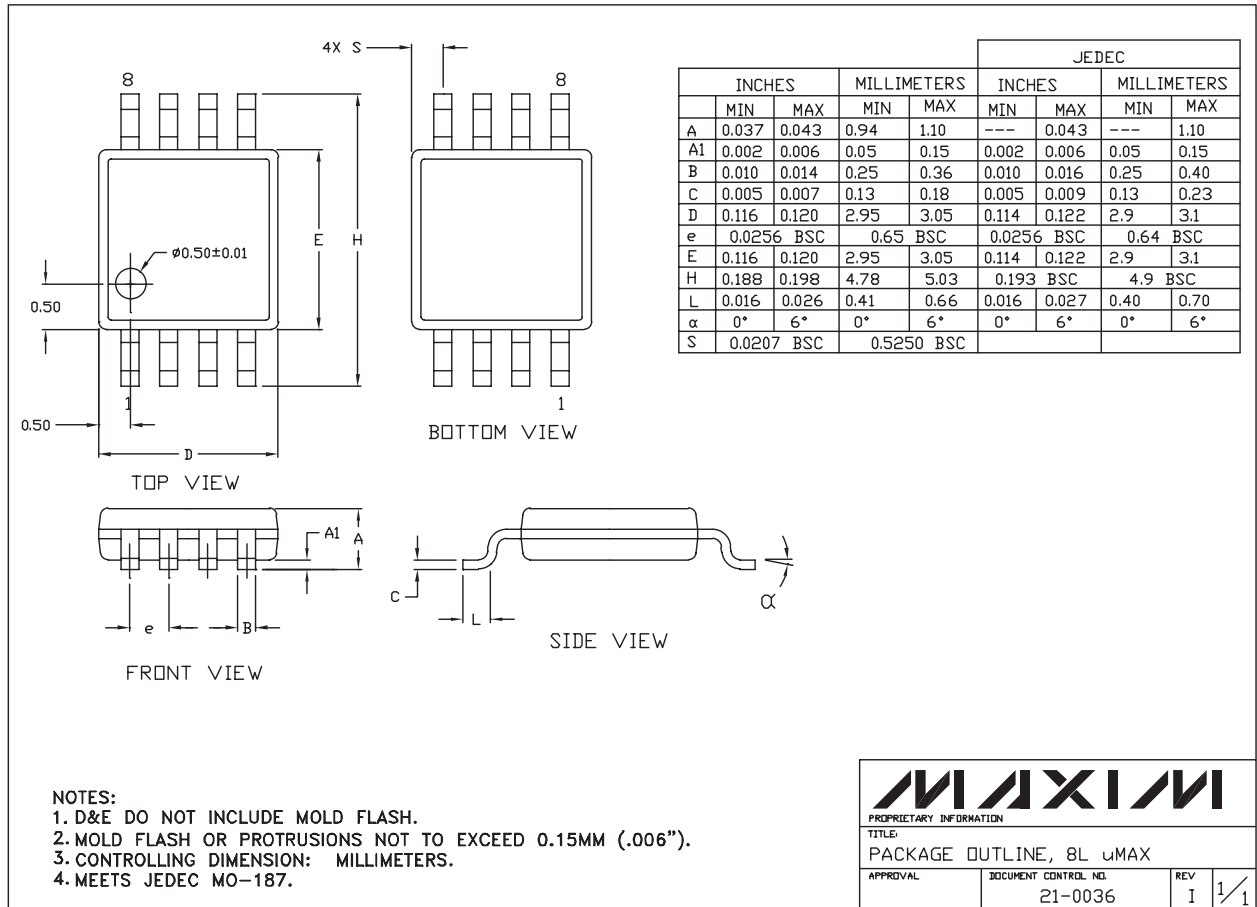

8LUMAXDLEFS

**MAXIM**  
 PREPROPRIETARY INFORMATION  
 TITLE:  
 PACKAGE OUTLINE, 8L uMAX  
 APPROVAL: \_\_\_\_\_ DOCUMENT CONTROL NO: 21-0036 REV: I 1/1

Maxim cannot assume responsibility for use of any circuitry other than circuitry entirely embodied in a Maxim product. No circuit patent licenses are implied. Maxim reserves the right to change the circuitry and specifications without notice at any time.

**Maxim Integrated Products, 120 San Gabriel Drive, Sunnyvale, CA 94086 408-737-7600 \_\_\_\_\_ 9**

Компания «Life Electronics» занимается поставками электронных компонентов импортного и отечественного производства от производителей и со складов крупных дистрибьюторов Европы, Америки и Азии.

С конца 2013 года компания активно расширяет линейку поставок компонентов по направлению коаксиальный кабель, кварцевые генераторы и конденсаторы (керамические, пленочные, электролитические), за счёт заключения дистрибьюторских договоров

Мы предлагаем:

- Конкурентоспособные цены и скидки постоянным клиентам.
- Специальные условия для постоянных клиентов.
- Подбор аналогов.
- Поставку компонентов в любых объемах, удовлетворяющих вашим потребностям.
- Приемлемые сроки поставки, возможна ускоренная поставка.
- Доставку товара в любую точку России и стран СНГ.
- Комплексную поставку.
- Работу по проектам и поставку образцов.
- Формирование склада под заказчика.
- Сертификаты соответствия на поставляемую продукцию (по желанию клиента).
- Тестирование поставляемой продукции.
- Поставку компонентов, требующих военную и космическую приемку.
- Входной контроль качества.
- Наличие сертификата ISO.

В составе нашей компании организован Конструкторский отдел, призванный помогать разработчикам, и инженерам.

Конструкторский отдел помогает осуществить:

- Регистрацию проекта у производителя компонентов.
- Техническую поддержку проекта.
- Защиту от снятия компонента с производства.
- Оценку стоимости проекта по компонентам.
- Изготовление тестовой платы монтаж и пусконаладочные работы.



Тел: +7 (812) 336 43 04 (многоканальный)

Email: [org@lifeelectronics.ru](mailto:org@lifeelectronics.ru)