

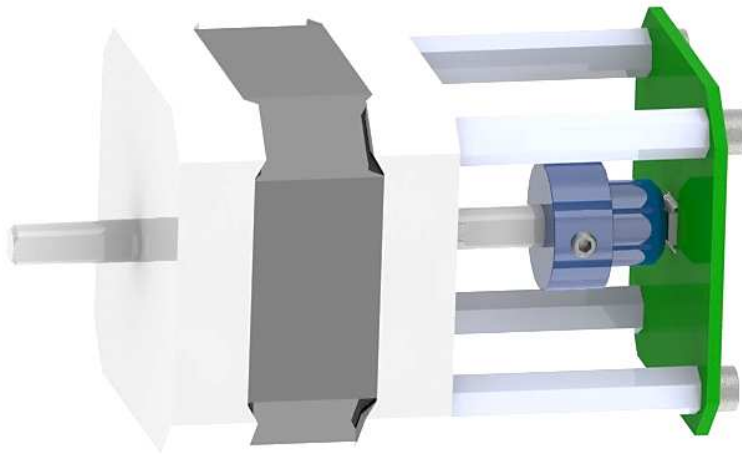

Operation Manual: AS5048-EK-AB-STM1.0



AS5048 Eval-Kit Stepper Motor



Table of Contents

1. General Description	2
2. Package and Board Description	2
3. How to get the EVK running	4
4. Mechanical Design Considerations	5
5. Schematics, Layout	6
Copyright.....	9
Disclaimer	9

1. General Description

The AS5048 Eval-Kit is designed to adapt standard size stepper motors with a contactless rotary position sensor. Rotation of the magnet holders is sensed by the rotary position sensor, soldered on the PCB board.

2. Package and Board Description

Content of the Eval-Kit:

- AS5048 board

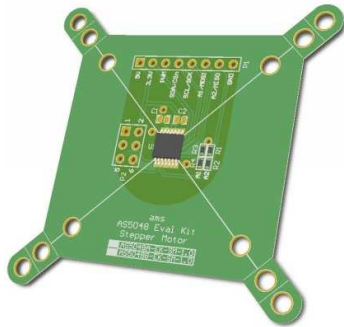

- 4 magnet holders



Ø 5mm



Ø 6mm



Ø 8mm



Ø 10mm

- 1 allen key (1.5mm)



- 1 quick start user guide

Figure 1:
Connector

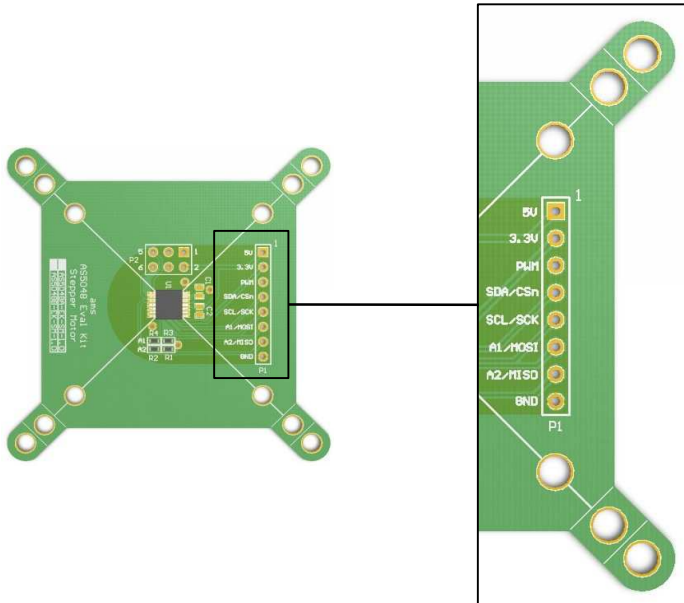

Table 1:
Connector pinout

Pin	Description	Info
1	GND	Ground
2	A2/MISO	SPI master in/slave out; shared with I2C address selection A2
3	A1/MOSI	SPI master out/slave in; shared with I2C address selection A1
4	SCL/SCK	SPI clock input; shared with I2C clock input
5	SDA/CSn	SPI chip select - active low; shared with I2C data pin
6	PWM	Pulse Width Modulation output
7	3V3	3.3V-Regulator Output.
8	5V	Positive Supply Voltage.

3. How to get the Eval-Kit running

Figure 2:
5V Power Option

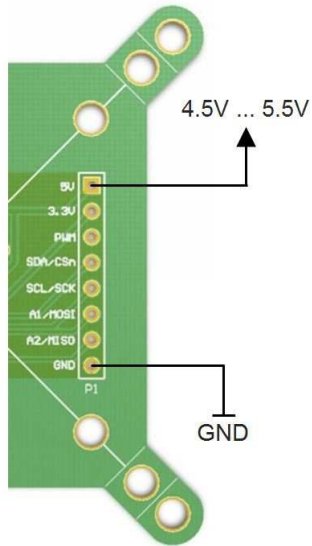
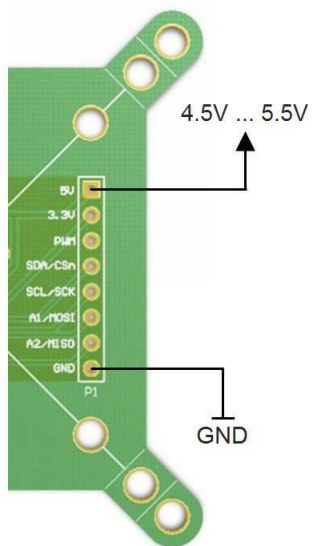

Figure 3:
3V Power Option



4. Mechanical Design Considerations

Table 2:
Motor References (Examples)

Part Number	Web Page	Manufacturer
17PY-X0XX	www.nmbtc.com	NMB Technologies Corporation - Motor Group
17PY-X8XX		
17PY-X4XX		
17H018D series	www.portescap.com	Portescap
17H118D series		
17H218D series		



Table 3:
Used Magnet

Part Number	Web Page	Manufacturer
2910041-1	www.dextermag.com	Dexter Magnetic Technologies



Additional recommended magnet suppliers refer to our homepage:

<http://www.ams.com/eng/Products/Magnetic-Encoders/Magnets2/Recommended-Magnet-Suppliers>

Figure 4:
Mounting the AS5048 Eval-Kit

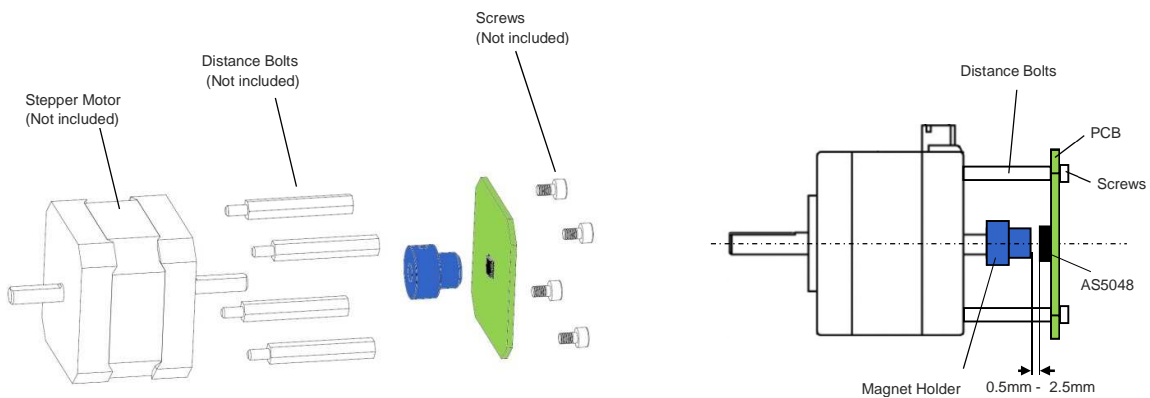

The AS5048 board can be mounted on double shaft motors. (See figure 4)

Screws and distance bolts are not included.

5. Schematics, Layout

Figure 5:
Schematic

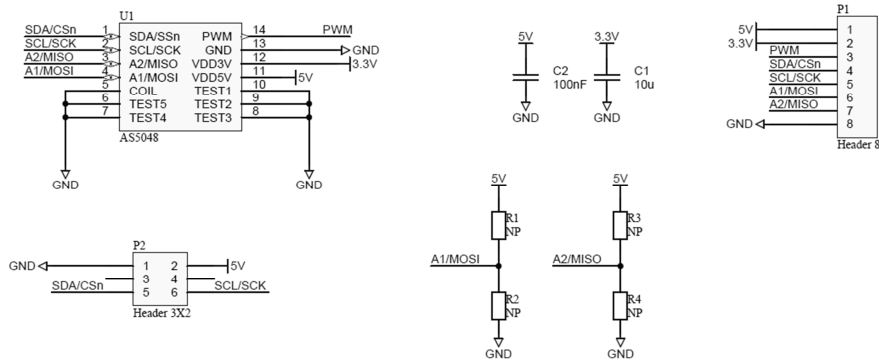

Figure 6:
Top Layer

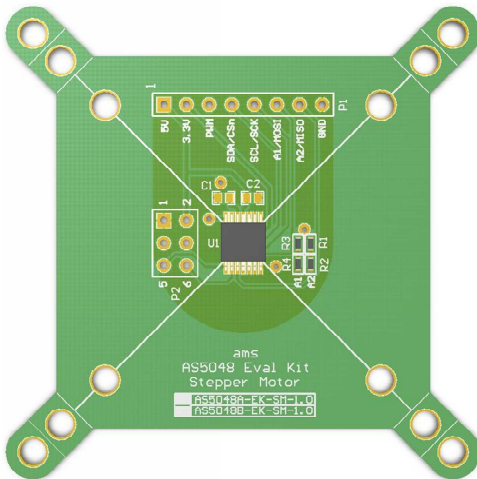

Figure 7:
Bottom Layer

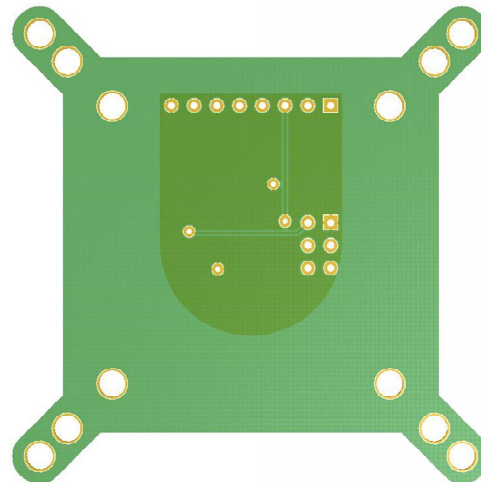

Table 4:
Bill of Materials

Pos	Part Number	Reference
1	PCB Board	PCB1
2	U1	AS5048
3	C1	10uF/10V/0603
4	C2	100nF/10V/0603

Figure 8:
Magnet Holder



Grub screw for fixing on the shaft of the motor.

Figure 9:
Magnet Holder Dimensions

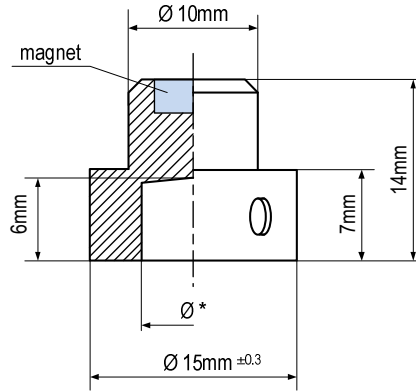

- *Ø 5mm
- *Ø 6mm
- *Ø 8mm
- *Ø 10mm

Figure 10:
Layout Dimensions

All values in mm

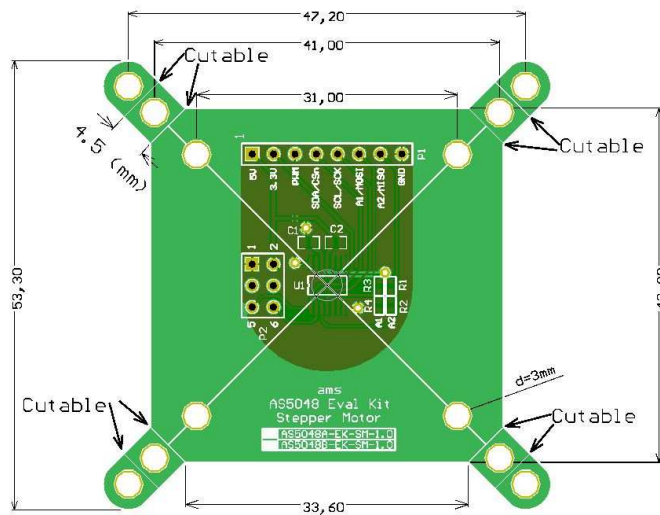

6. Ordering Information

Table 5:
Ordering Information

Ordering Code	Description
AS5048A-EK-AB-STM1.0	AS5048A Eval-Kit Stepper Motor with SPI interface
AS5048B-EK-AB-STM1.0	AS5048B Eval-Kit Stepper Motor with I2C interface

Revisions History

Revision	Date	Description
1.0	August 6, 2012	First version

Copyright

Copyright © 1997-2012, ams AG, Tobelbader Strasse 30, 8141 Unterpemstaetten, Austria-Europe.
Trademarks Registered ®. All rights reserved. The material herein may not be reproduced, adapted, merged, translated, stored, or used without the prior written consent of the copyright owner.

All products and companies mentioned are trademarks or registered trademarks of their respective companies.

Disclaimer

Devices sold by ams AG are covered by the warranty and patent indemnification provisions appearing in its Term of Sale. ams AG makes no warranty, express, statutory, implied, or by description regarding the information set forth herein or regarding the freedom of the described devices from patent infringement. ams AG reserves the right to change specifications and prices at any time and without notice. Therefore, prior to designing this product into a system, it is necessary to check with ams AG for current information.

This product is intended for use in normal commercial applications. Applications requiring extended temperature range, unusual environmental requirements, or high reliability applications, such as military, medical life-support or lifesustaining equipment are specifically not recommended without additional processing by ams AG for each application. For shipments of less than 100 parts the manufacturing flow might show deviations from the standard production flow, such as test flow or test location.

The information furnished here by ams AG is believed to be correct and accurate. However, ams AG shall not be liable to recipient or any third party for any damages, including but not limited to personal injury, property damage, loss of profits, loss of use, interruption of business or indirect, special, incidental or consequential damages, of any kind, in connection with or arising out of the furnishing, performance or use of the technical data herein. No obligation or liability to recipient or any third party shall arise or flow out of ams AG rendering of technical or other services.

Contact Information

Headquarters

ams AG
Tobelbader Strasse 30
8141 Unterpemstaetten
Austria

T. +43 (0) 3136 500 0

For Sales Offices, Distributors and Representatives, please visit:

<http://www.ams.com/contact>

Компания «Life Electronics» занимается поставками электронных компонентов импортного и отечественного производства от производителей и со складов крупных дистрибьюторов Европы, Америки и Азии.

С конца 2013 года компания активно расширяет линейку поставок компонентов по направлению коаксиальный кабель, кварцевые генераторы и конденсаторы (керамические, пленочные, электролитические), за счёт заключения дистрибьюторских договоров

Мы предлагаем:

- Конкурентоспособные цены и скидки постоянным клиентам.
- Специальные условия для постоянных клиентов.
- Подбор аналогов.
- Поставку компонентов в любых объемах, удовлетворяющих вашим потребностям.
- Приемлемые сроки поставки, возможна ускоренная поставка.
- Доставку товара в любую точку России и стран СНГ.
- Комплексную поставку.
- Работу по проектам и поставку образцов.
- Формирование склада под заказчика.
- Сертификаты соответствия на поставляемую продукцию (по желанию клиента).
- Тестирование поставляемой продукции.
- Поставку компонентов, требующих военную и космическую приемку.
- Входной контроль качества.
- Наличие сертификата ISO.

В составе нашей компании организован Конструкторский отдел, призванный помогать разработчикам, и инженерам.

Конструкторский отдел помогает осуществить:

- Регистрацию проекта у производителя компонентов.
- Техническую поддержку проекта.
- Защиту от снятия компонента с производства.
- Оценку стоимости проекта по компонентам.
- Изготовление тестовой платы монтаж и пусконаладочные работы.



Тел: +7 (812) 336 43 04 (многоканальный)

Email: org@lifeelectronics.ru