

PRIMARY SIDE POWER SWITCHER FOR FLYBACK/NON-ISOLATED BUCK SMPS

Description

The AP3965/66/71 consists of a primary side regulation controller and a high voltage transistor, and is specially designed for off-line power supplies within 12W output power or non-isolated buck applications within 5W. Typical applications include adapter for ADSL, auxiliary supplies or open frame types for appliances.

The AP3965/66/71 operates at pulse frequency modulation (PFM), and provides accurate constant voltage, constant current (CV/CC) regulation without requiring an opto-coupler and secondary control circuitry. It has internal cable compensation function for tight constant voltage regulation.

The AP3965/66/71 solution has fewer component numbers, smaller size, and lower total cost.

The AP3965 is packaged in SO7. The AP3966/71 is available in PDIP-7.

Features

- Primary Side Control for Eliminating Opto-coupler and Secondary CV/CC Control Circuitry
- Built-in NPN Transistor with 700V_{CBO}
- Low Start-up Current: 0.2µA (Typ)
- Internal Output Cable Voltage Drop Compensation
- Random Frequency Modulation for Low EMI
- Short Circuit Protection
- Low Total Cost Solution
- Output Power Range (Note 1):
 - AP3965 for 5W Adapter and 3W Buck
 - AP3966 for 10W Adapter and 4.5W Buck
 - AP3971 for 12W Adapter and 5W Buck
- **Totally Lead-free & Fully RoHS Compliant (Note 2 & 3)**
- **Halogen and Antimony Free. "Green" Device (Note 4)**

- Notes:
1. Typical continuous power in a non-ventilated enclosed adapter measured at +50°C ambient.
 2. No purposely added lead. Fully EU Directive 2002/95/EC (RoHS) & 2011/65/EU (RoHS 2) compliant.
 3. See http://www.diodes.com/quality/lead_free.html for more information about Diodes Incorporated's definitions of Halogen- and Antimony-free, "Green" and Lead-free.
 4. Halogen- and Antimony-free "Green" products are defined as those which contain <900ppm bromine, <900ppm chlorine (<1500ppm total Br + Cl) and <1000ppm antimony compounds.

Pin Assignments

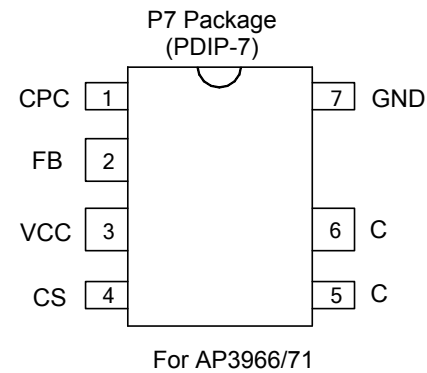
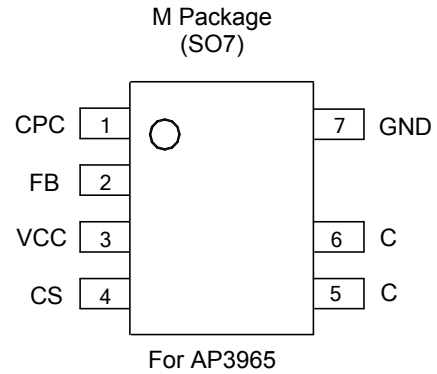

Applications

- Adapters
- Set Top Boxes
- Auxiliary Supplies
- Appliances

Typical Applications Circuit

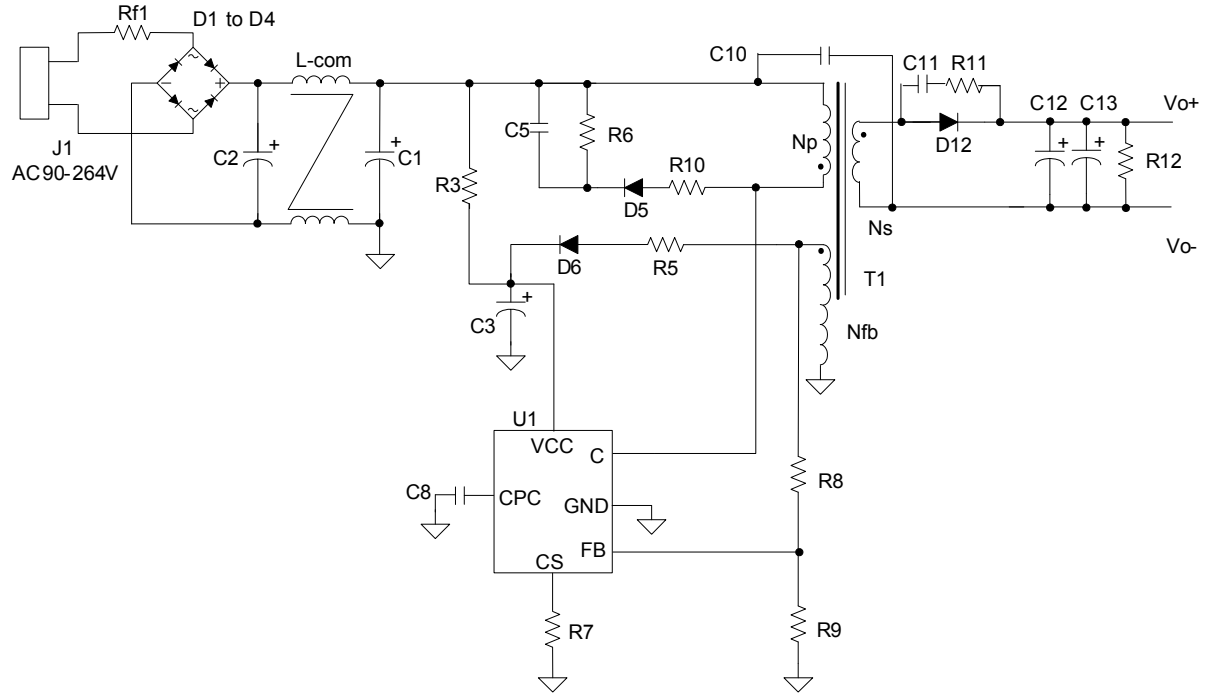

For AP3971 (12V/1A)

Item	Function	QTY	Item	Function	QTY
C1,C2	10 μ F/400V, electrolytic	2	U1	AP3971, PDIP-7	1
C3	4.7 μ F/50V, electrolytic	1	Rf1	2A/250V, fuse	1
C5	1nF/250V, ceramic	1	R3	3.3M Ω /0.25W	1
C8	0.1 μ F, 0805	1	R5	3.9 Ω , 0805	1
C10	1nF/250V _{AC} , Y1 capacitor	1	R6	150k Ω /0.25W	1
C11	1nF, 0805	1	R7	0.62 Ω , 1206	1
C12, C13	470 μ F/16V	2	R8	31k Ω , 0805	1
D1 to D6	1N4007, rectifier diode	6	R9	13k Ω , 0805	1
D12	MBR3100, schottky diode	1	R10	360 Ω , 0805	1
L-com	EE10, 15mH, Common inductor	1	R11	27 Ω , 0805	1
T1	EE19 core, PC40, transformer	1	R12	1.2k Ω , 0805	1

Pin Descriptions

Pin Number	Pin Name	Function
1	CPC	This pin connects a capacitor to GND for output cable compensation
2	FB	The voltage feedback from auxiliary winding
3	VCC	This pin receives rectified voltage from the auxiliary winding of the transformer
4	CS	Current sense for primary side of transformer
5, 6	C	This pin is connected with an internal power BJT's collector
7	GND	This pin is the signal reference ground

Functional Block Diagram

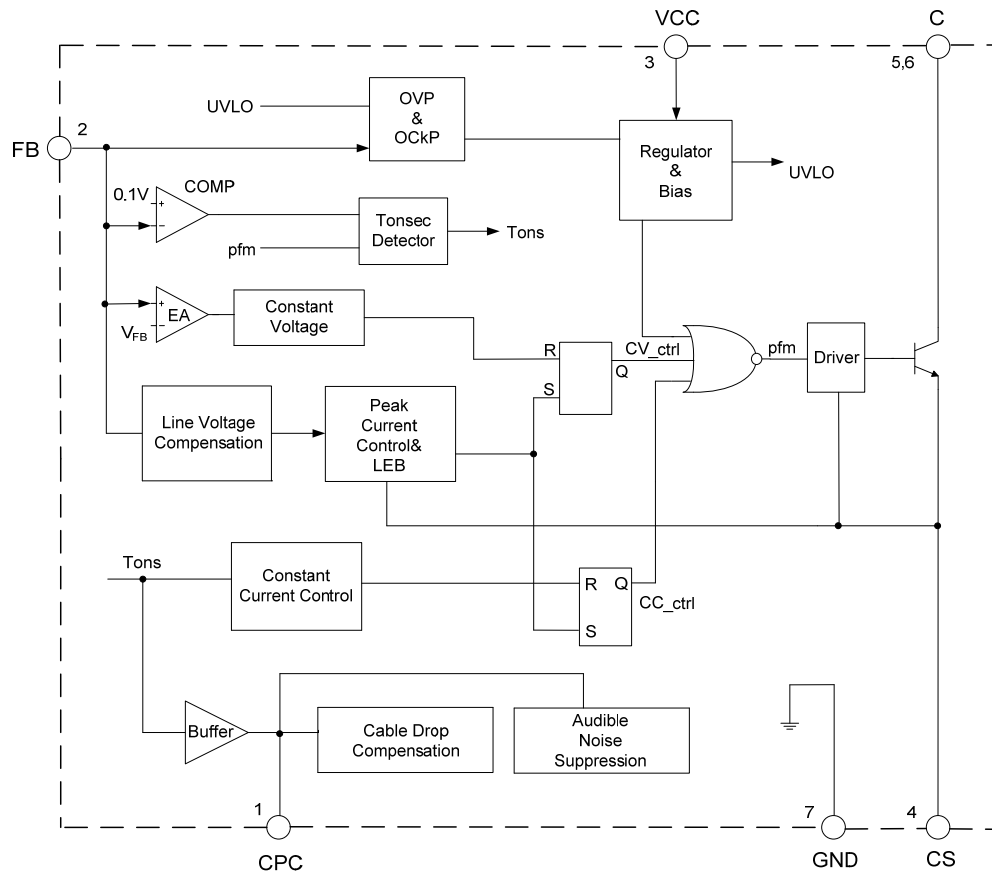

Absolute Maximum Ratings (Note 5)

Symbol	Parameter	Rating		Unit
V _{CC}	Supply Voltage	-0.3 to +22		V
V _{FB}	FB Input Voltage	-1 to +10		V
V _{CBO}	Collector-emitter Voltage	700		V
–	Collector DC Current	AP3965	1.5	A
		AP3966	3.2	
		AP3971	4	
T _J	Operating Junction Temperature	150		°C
T _{STG}	Storage Temperature	-65 to +150		°C
T _{LEAD}	Lead Temperature (Soldering, 10 sec)	300		°C
–	ESD (Machine Model)	200		V
–	ESD (Human Body Model)	2000		V
P _D	Total Power Dissipation	AP3965	0.9	W
		AP3966	1.4	
		AP3971	1.5	

Note: 5. Stresses greater than those listed under "Absolute Maximum Ratings" may cause permanent damage to the device. These are stress ratings only, and functional operation of the device at these or any other conditions beyond those indicated under "Recommended Operating Conditions" is not implied. Exposure to "Absolute Maximum Ratings" for extended periods may affect device reliability.

Recommended Operating Conditions

Symbol	Parameter	Min	Max	Unit
V _{CC}	Supply Voltage	–	22	V
T _{OP}	Operating Temperature Range	-40	+85	°C
f _{MAX}	Maximum Operating Frequency	–	60	kHz

Thermal Impedance (Note 6)

Symbol	Parameter	Value		Unit
θ _{JA}	Junction to Ambient	AP3965	80	°C/W
		AP3966	50	
		AP3971	45	
θ _{JC}	Junction to Case	AP3965	40	
		AP3966	26	
		AP3971	22	

Note: 6. When mounted a standard single-sided FR4 board with 300mm² Cu (at least 35µm thick) connected to all collectors and CS pins.

Electrical Characteristics (@ $V_{CC}=15V$, $T_J = +25^{\circ}C$, unless otherwise specified.)

Symbol	Parameters	Conditions	Min	Typ	Max	Unit
UVLO Section						
V_{ON}	Turn-on Voltage	–	13	15	17	V
V_{OFF}	Turn-off Voltage	No drive current	4.5	5.3	6.3	V
Standby Current Section						
I_{ST}	Start-up Current	$V_{CC} = V_{ON} - 0.5V$	–	0.2	0.6	μA
I_{CC}	Operating Current	–	320	435	550	
Feedback Input Section						
I_{FB}	FB Input Current	$V_{FB} = 4V$	1.5	3.5	5.5	μA
V_{FB}	FB Threshold Voltage	–	4.324	4.4	4.476	V
Power Transistor Section						
$V_{CE(SAT)}$	Collector-emitter Saturation Voltage	AP3965: $I_C = 0.5A$ AP3966/71: $I_C = 1A$	–	–	0.3	V
h_{FE}	DC Current Gain	AP3965	14	17	–	–
		AP3966/71	17	26	–	
I_{CEO}	Leakage Current	–	–	–	60	nA
Over Temperature Protection						
T_{SHDN}	Shutdown Temperature	Surface temperature	125	160	–	$^{\circ}C$
–	Temperature Hysteresis	–	–	40	–	$^{\circ}C$

Performance Characteristics

Turn-on Voltage vs. Ambient Temperature

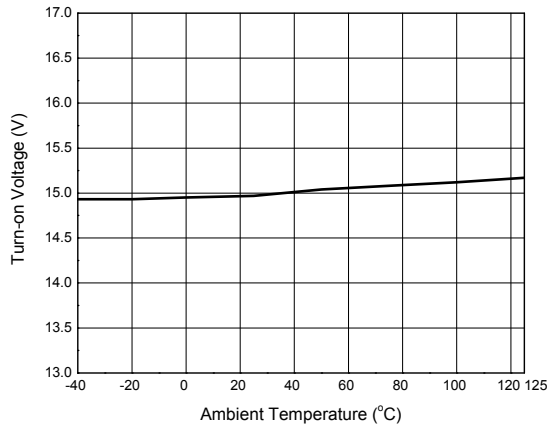

Turn-off Voltage vs. Ambient Temperature

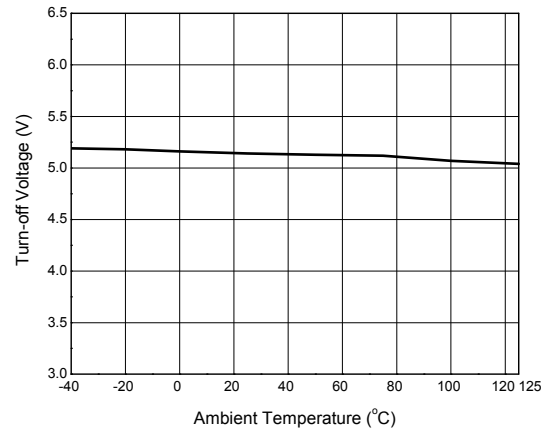

Operating Current vs. Ambient Temperature

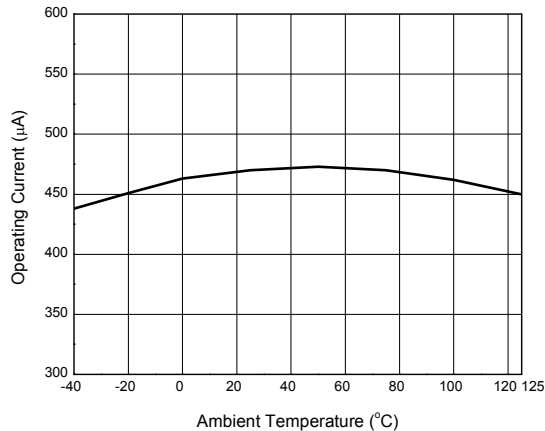

Operation Description

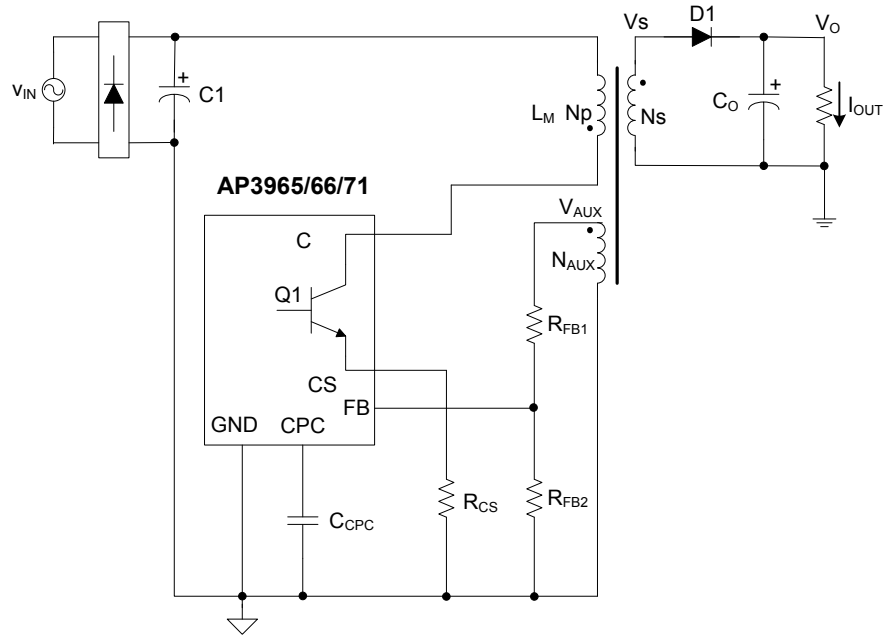

Figure 1 Simplified Flyback Converter Controlled by AP3965/66/71

Constant Primary Peak Current

The primary current $I_p(t)$ is sensed by a current sense resistor R_{CS} as shown in Figure 1.

The current rises up linearly at a rate of:

$$\frac{di_p(t)}{dt} = \frac{v_g(t)}{L_M} \dots\dots\dots(1)$$

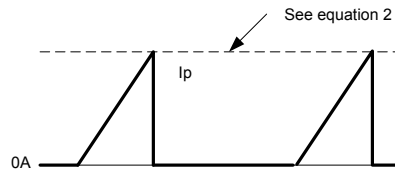

Figure 2 Primary Current Waveform

As illustrated in Figure 2, when the current $I_p(t)$ rises up to I_{pk} , the switch Q1 turns off. The constant peak current is given by:

$$I_{pk} = \frac{V_{cs}}{R_{cs}} \dots\dots\dots(2)$$

The energy stored in the magnetizing inductance L_M each cycle is therefore:

$$E_g = \frac{1}{2} \cdot L_M \cdot I_{pk}^2 \dots\dots\dots(3)$$

So the power transferring from input to output is given by:

$$P = \frac{1}{2} \cdot L_M \cdot I_{pk}^2 \cdot f_{sw} \dots\dots\dots(4)$$

Where f_{sw} is the switching frequency. When the peak current I_{pk} is constant, the output power depends on the switching frequency f_{sw} .

Operation Description (cont.)

Constant Voltage Operation

The AP3965/66/71 captures the auxiliary winding feedback voltage at FB pin and operates in constant-voltage (CV) mode to regulate the output voltage. Assuming the secondary winding is master, the auxiliary winding is slave during the D1 on-time. The auxiliary voltage is given by:

$$V_{AUX} = \frac{N_{AUX}}{N_S} \cdot (V_o + V_d) \dots\dots\dots(5)$$

Where V_d is the diode forward drop voltage, N_{AUX} is the turns of auxiliary winding, and N_S is the turns of secondary winding.

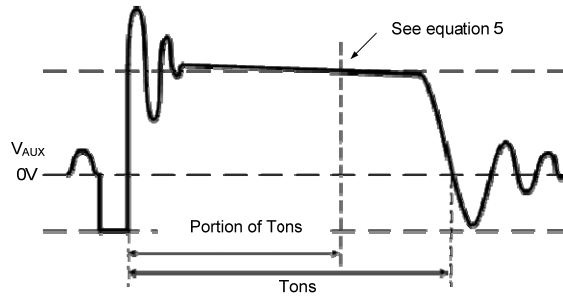

Figure 3. Auxiliary Voltage Waveform

The output voltage is different from the secondary voltage in a diode forward drop voltage V_d which depends on the current. If the secondary voltage is always detected at a constant secondary current, the difference between the output voltage and the secondary voltage will be a fixed V_d . The voltage detection point is portion of Tons after D1 is turned on. The CV loop control function of AP3965/66/71 then generates a D1 off-time to regulate the output voltage.

Constant Current Operation

The AP3965/66/71 is designed to work in constant current (CC) mode. Figure 4 shows the secondary current waveforms.

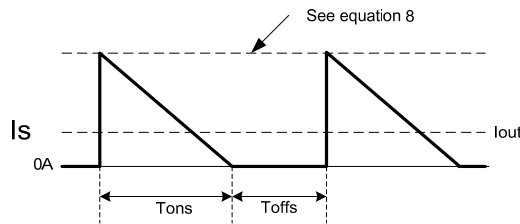

Figure 4. Secondary Current Waveform

In CC operation, the CC loop control function of AP3965/66/71 will keep a fixed proportion between D1 on-time T_{ons} and D1 off-time T_{offs} by discharging or charging the built-in capacitance connected. This fixed proportion is

$$\frac{T_{ons}}{T_{offs}} = \frac{4}{2} \dots\dots\dots(6)$$

The relation between the output constant-current and secondary peak current I_{pks} is given by:

$$I_{OUT} = \frac{1}{2} \cdot I_{pks} \cdot \frac{T_{ons}}{T_{ons} + T_{offs}} \dots\dots\dots(7)$$

At the instant of D1 turn-on, the primary current transfers to the secondary at an amplitude of:

$$I_{pks} = \frac{N_P}{N_S} \cdot I_{pk} \dots\dots\dots(8)$$

Operation Description (cont.)

Thus the output constant current is given by:

$$I_{OUT} = \frac{1}{3} \cdot \frac{N_P}{N_S} \cdot I_{pk} \dots\dots\dots(9)$$

Leading Edge Blanking (LEB)

When the power switch is turned on, a turn-on spike on the output pulse rising edge will occur on the sense-resistor. To avoid false termination of the switching pulse, a typical 500ns leading edge blanking is built in. During this blanking period, the current sense comparator is disabled and the gate driver cannot be switched off.

The built-in LEB in AP3965/66/71 has shorter delay time from current sense terminal to output pulse than those IC solutions adopting external RC filter as LEB.

Built-in Cable Compensation

The AP3965/66/71 has built-in fixed voltage of 0.35V typical to compensate the drop of output cable when the load is changed from zero to full load. A typical 0.01µF external capacitor connected to the CPC pin is used to smooth voltage signal for cable compensation.

Over Temperature Protection

The AP3965/66/71 has internal thermal sensing circuit to shut down the PFM driver output when the die temperature reaches 160°C typical. When the die temperature drops about 40°C, the IC will recover automatically to normal operation.

Ordering Information

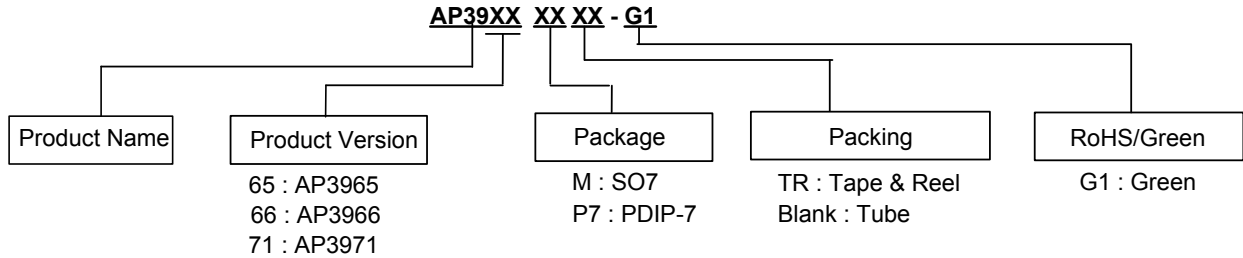

Diodes IC's Pb-free products with "G1" suffix in the part number, are RoHS compliant and green.

Package	Temperature Range	Part Number	Marking ID	Packing
SO7	-40°C to 85°C	AP3965MTR-G1	3965M-G1	4,000/Tape & Reel
PDIP-7		AP3966P7-G1	AP3966P7-G1	50/Tube
		AP3971P7-G1	AP3971P7-G1	50/Tube

Marking Information

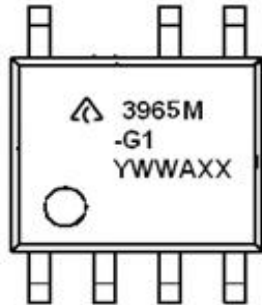

First and Second Lines: Logo and Marking ID
Third Line: Date Code
Y: Year
WW: Work Week of Molding
A: Assembly House Code
XX: 7th and 8th Digits of Batch No.

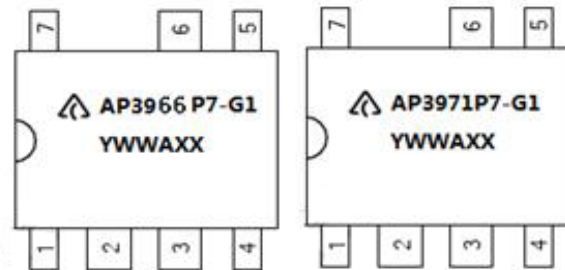

First Line: Logo and Marking ID
Second Line: Date Code
Y: Year
WW: Work Week of Molding
A: Assembly House Code
XX: 7th and 8th Digits of Batch No.

Package Outline Dimensions (All dimensions in mm(inch).)

S07

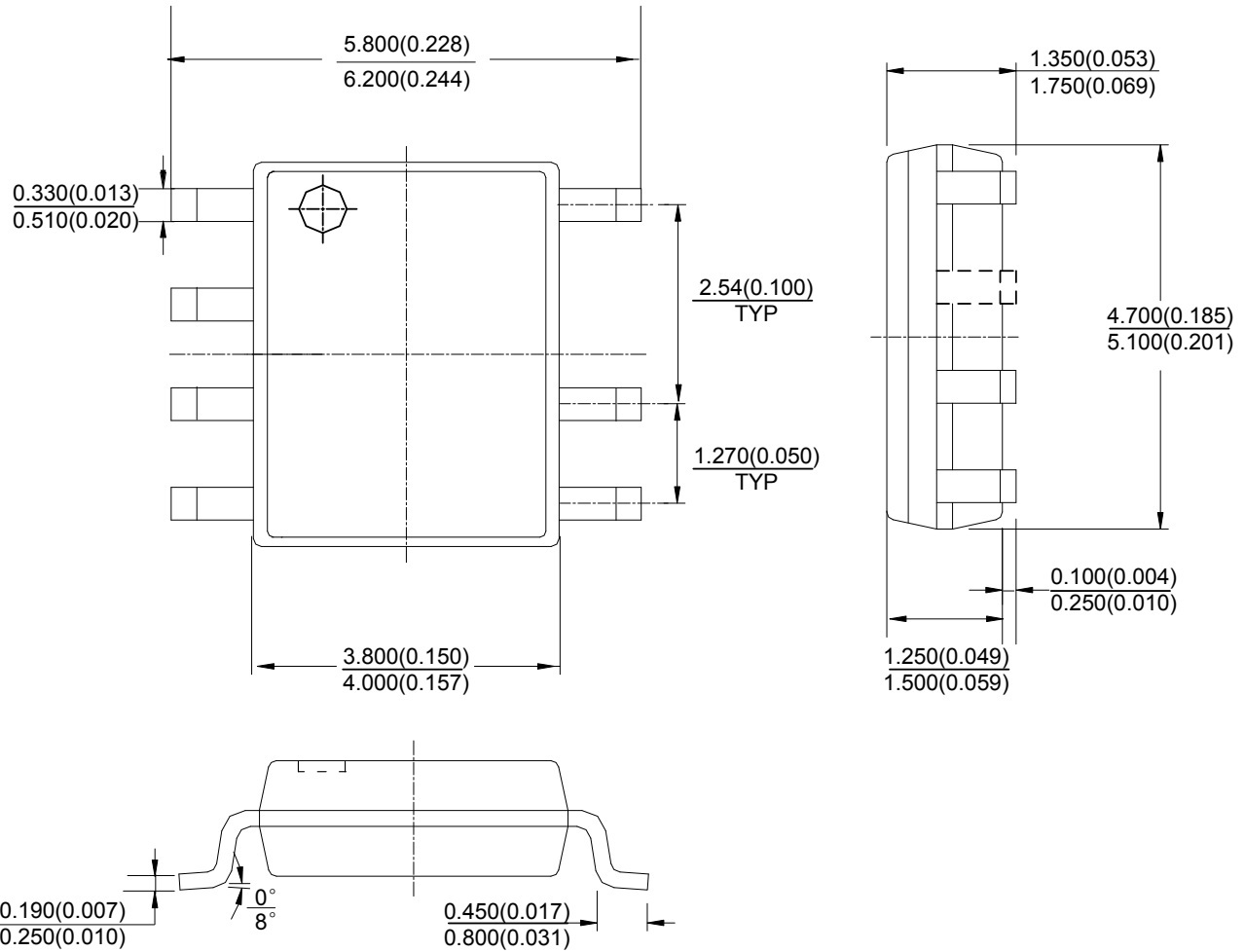

Note: Eject hole, oriented hole and mold mark is optional.

Package Outline Dimensions (cont.) (All dimensions in mm (inch).)

PDIP-7

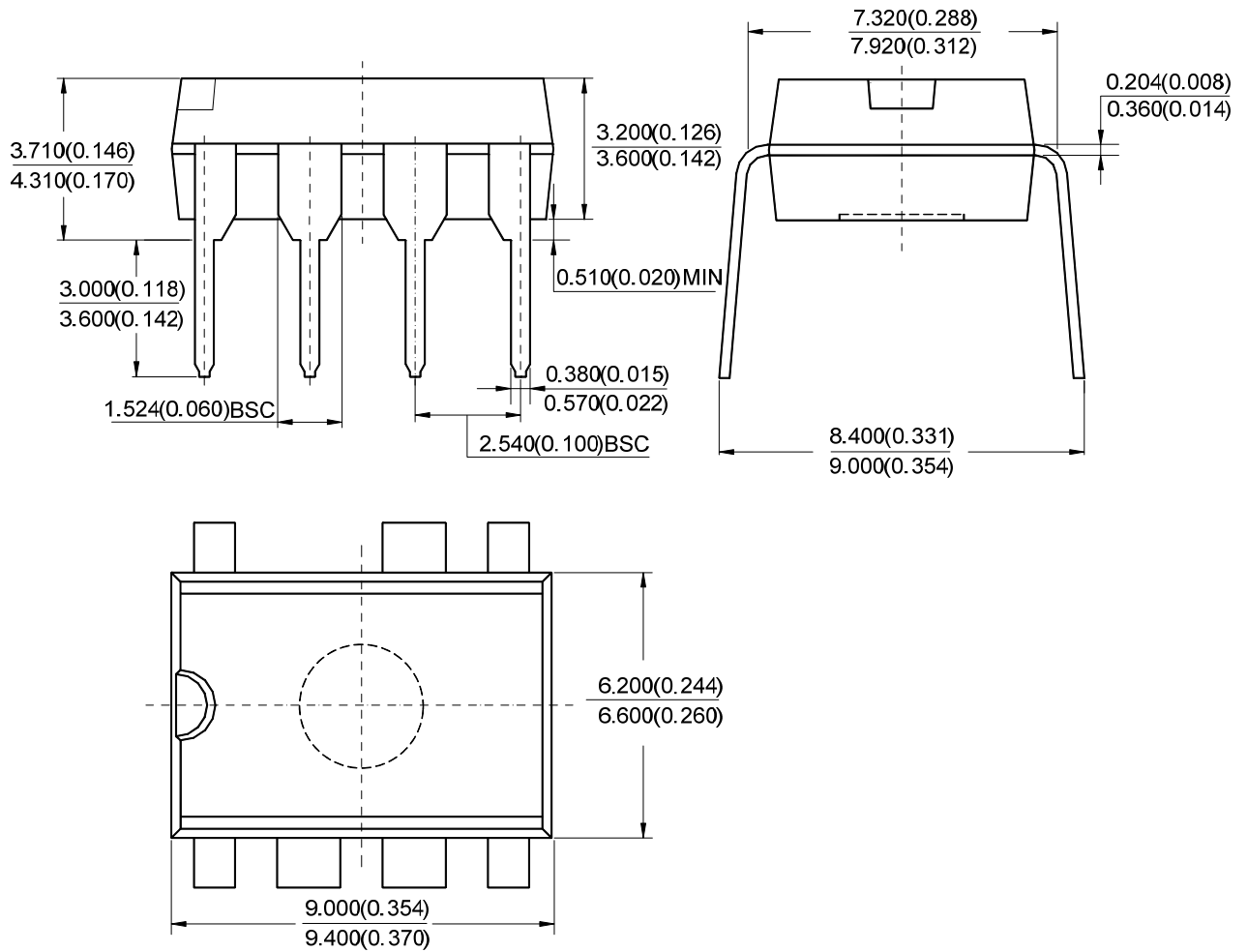

Note: Eject hole, oriented hole and mold mark is optional

Suggested Pad Layout

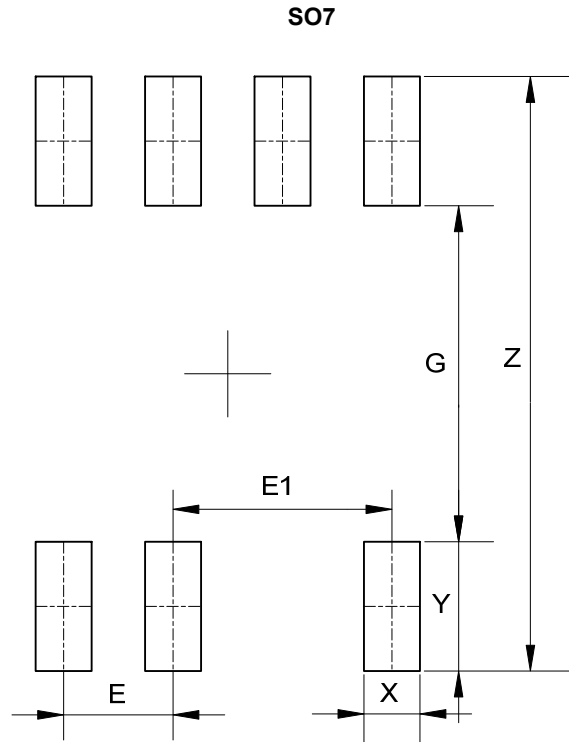

Dimensions	Z (mm)/(inch)	G (mm)/(inch)	X (mm)/(inch)	Y (mm)/(inch)	E (mm)/(inch)	E1 (mm)/(inch)
Value	6.900/0.272	3.900/0.154	0.650/0.026	1.500/0.059	1.270/0.050	2.540/0.100

IMPORTANT NOTICE

DIODES INCORPORATED MAKES NO WARRANTY OF ANY KIND, EXPRESS OR IMPLIED, WITH REGARDS TO THIS DOCUMENT, INCLUDING, BUT NOT LIMITED TO, THE IMPLIED WARRANTIES OF MERCHANTABILITY AND FITNESS FOR A PARTICULAR PURPOSE (AND THEIR EQUIVALENTS UNDER THE LAWS OF ANY JURISDICTION).

Diodes Incorporated and its subsidiaries reserve the right to make modifications, enhancements, improvements, corrections or other changes without further notice to this document and any product described herein. Diodes Incorporated does not assume any liability arising out of the application or use of this document or any product described herein; neither does Diodes Incorporated convey any license under its patent or trademark rights, nor the rights of others. Any Customer or user of this document or products described herein in such applications shall assume all risks of such use and will agree to hold Diodes Incorporated and all the companies whose products are represented on Diodes Incorporated website, harmless against all damages.

Diodes Incorporated does not warrant or accept any liability whatsoever in respect of any products purchased through unauthorized sales channel. Should Customers purchase or use Diodes Incorporated products for any unintended or unauthorized application, Customers shall indemnify and hold Diodes Incorporated and its representatives harmless against all claims, damages, expenses, and attorney fees arising out of, directly or indirectly, any claim of personal injury or death associated with such unintended or unauthorized application.

Products described herein may be covered by one or more United States, international or foreign patents pending. Product names and markings noted herein may also be covered by one or more United States, international or foreign trademarks.

This document is written in English but may be translated into multiple languages for reference. Only the English version of this document is the final and determinative format released by Diodes Incorporated.

LIFE SUPPORT

Diodes Incorporated products are specifically not authorized for use as critical components in life support devices or systems without the express written approval of the Chief Executive Officer of Diodes Incorporated. As used herein:

A. Life support devices or systems are devices or systems which:

1. are intended to implant into the body, or
2. support or sustain life and whose failure to perform when properly used in accordance with instructions for use provided in the labeling can be reasonably expected to result in significant injury to the user.

B. A critical component is any component in a life support device or system whose failure to perform can be reasonably expected to cause the failure of the life support device or to affect its safety or effectiveness.

Customers represent that they have all necessary expertise in the safety and regulatory ramifications of their life support devices or systems, and acknowledge and agree that they are solely responsible for all legal, regulatory and safety-related requirements concerning their products and any use of Diodes Incorporated products in such safety-critical, life support devices or systems, notwithstanding any devices- or systems-related information or support that may be provided by Diodes Incorporated. Further, Customers must fully indemnify Diodes Incorporated and its representatives against any damages arising out of the use of Diodes Incorporated products in such safety-critical, life support devices or systems.

Copyright © 2013, Diodes Incorporated

www.diodes.com

Компания «Life Electronics» занимается поставками электронных компонентов импортного и отечественного производства от производителей и со складов крупных дистрибьюторов Европы, Америки и Азии.

С конца 2013 года компания активно расширяет линейку поставок компонентов по направлению коаксиальный кабель, кварцевые генераторы и конденсаторы (керамические, пленочные, электролитические), за счёт заключения дистрибьюторских договоров

Мы предлагаем:

- Конкурентоспособные цены и скидки постоянным клиентам.
- Специальные условия для постоянных клиентов.
- Подбор аналогов.
- Поставку компонентов в любых объемах, удовлетворяющих вашим потребностям.
- Приемлемые сроки поставки, возможна ускоренная поставка.
- Доставку товара в любую точку России и стран СНГ.
- Комплексную поставку.
- Работу по проектам и поставку образцов.
- Формирование склада под заказчика.
- Сертификаты соответствия на поставляемую продукцию (по желанию клиента).
- Тестирование поставляемой продукции.
- Поставку компонентов, требующих военную и космическую приемку.
- Входной контроль качества.
- Наличие сертификата ISO.

В составе нашей компании организован Конструкторский отдел, призванный помогать разработчикам, и инженерам.

Конструкторский отдел помогает осуществить:

- Регистрацию проекта у производителя компонентов.
- Техническую поддержку проекта.
- Защиту от снятия компонента с производства.
- Оценку стоимости проекта по компонентам.
- Изготовление тестовой платы монтаж и пусконаладочные работы.



Тел: +7 (812) 336 43 04 (многоканальный)
Email: org@lifeelectronics.ru