

# HCMS-235x

CMOS Extended Temperature Range

5 x 7 Alphanumeric Display



## Data Sheet



### Description

This sunlight viewable 5 x 7 LED four-character display is contained in 12 pin dual-in-line packages designed for displaying alphanumeric information. The display is designed with on-board CMOS integrated circuits. Two CMOS ICs form an on-board 28-bit serial-in/parallel-out shift register with constant current output LED row drivers. Decoded column data is clocked into the on-board shift register for each refresh cycle. Full character display is achieved with external column strobing.

### Typical Applications

- Avionics
- Communication systems
- Fire control systems
- Radar systems

### Features

- On-Board low power CMOS IC
  - Integrated shift register with constant current LED drivers
- Wide operating temperature range
  - 55°C to +100°C
- Compact glass ceramic 4 character package
  - Series X-Y stackable
- Sunlight viewable
- 5 x 7 LED matrix displays full ASCII set
- Character height of 5.0 mm (0.20 inch)
- Wide viewing angle
  - X Axis =  $\pm 50^\circ$
  - Y Axis =  $\pm 65^\circ$
- Usable in night vision lighting applications

## Package Dimensions

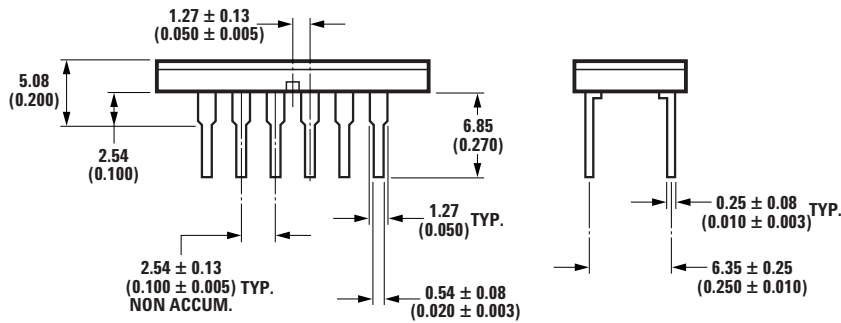
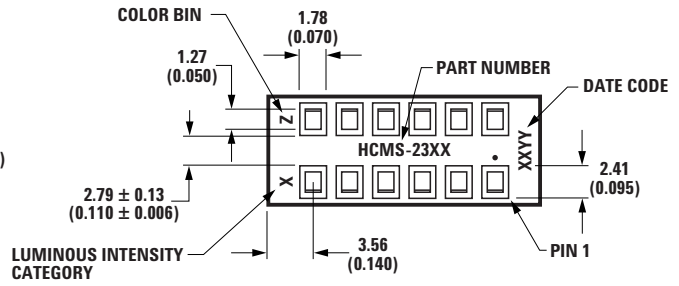
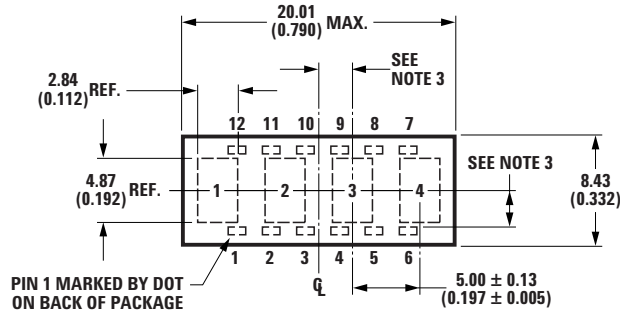

PIN	FUNCTION	PIN	FUNCTION
1	COLUMN 1	7	DATA OUT
2	COLUMN 2	8	VB
3	COLUMN 3	9	V <sub>DD</sub>
4	COLUMN 4	10	CLOCK
5	COLUMN 5	11	GROUND
6	INT. CONNECT*	12	DATA IN

\* DO NOT CONNECT OR USE

### NOTES:

- DIMENSIONS IN MILLIMETERS (INCHES).
- UNLESS OTHERWISE SPECIFIED, THE TOLERANCE ON ALL DIMENSIONS IS  $\pm 0.38$  mm ( $\pm 0.015$ ).
- CHARACTERS ARE CENTERED WITH RESPECT TO LEADS WITHIN  $\pm 0.13$  mm ( $\pm 0.005$ ).
- LEAD MATERIAL IS COPPER ALLOY, SOLDER DIPPED.

## Absolute Maximum Ratings

Parameter	Value
Supply Voltage V <sub>DD</sub> to Ground	-0.3 V to 7.0 V <sup>[1]</sup>
Data Input, Data Output, V <sub>B</sub>	-0.3 V to V <sub>DD</sub>
Column Input Voltage, V <sub>COL</sub>	-0.3 V to V <sub>DD</sub>
Free Air Operating Temperature Range, T <sub>A</sub>	-55°C to +100°C
Storage Temperature Range, T <sub>S</sub>	-55°C to +100°C
Maximum Allowable Package Power Dissipation, P <sub>D</sub> <sup>[2,3]</sup> at T <sub>A</sub> = 71°C	1.31 Watts
Through-the-Wave Solder Temperature <sup>[4]</sup>	250°C for 3 secs. max.
Solder Dipping Temperature <sup>[4]</sup>	260°C for 5 secs. max.
ESD Protection @ 1.5 kΩ, 100 pF	V <sub>Z</sub> = 4 kV

### Notes:

- Maximum duration 2 seconds.
- Maximum allowable power dissipation is derived from V<sub>DD</sub> = 5.25 V, V<sub>B</sub> = 2.4 V, V<sub>COL</sub> = 3.5 V, 20 LEDs ON per character, 20% DF.
- HCMS-2353 derate above 71°C at 23 mW/°C, R<sub>θJ-A</sub> = 45°C/W.  
Derating based on R<sub>θPC-A</sub> = 35°C/W per display for printed circuit board assembly.
- 1.59 mm (0.063") Below Body

## Recommended Operating Conditions

### Over Operating Range (–55°C to + 100°C)

Parameter	Symbol	Min.	Typ.	Max	Units
Supply Voltage	V <sub>DD</sub>	4.75	5.00	5.25	V
Data Out Current, Low State	I <sub>OL</sub>			1.6	mA
Data Out Current, High State	I <sub>OH</sub>			–0.5	mA
Column Input Voltage	V <sub>COL</sub>	2.75	3.0	3.5	V
Setup Time	t <sub>SETUP</sub>	10			ns
Hold Time	t <sub>HOLD</sub>	25			ns
Clock Pulse Width High	t <sub>WH(CLOCK)</sub>	50			ns
Clock Pulse Width Low	t <sub>WL(CLOCK)</sub>	50			ns
Clock High to Low Transition	t <sub>THL</sub>			200	ns
Clock Frequency	f <sub>CLOCK</sub>			5	MHz

## Electrical Characteristics

### Over Operating Range (–55°C to + 100°C)

Parameter	Symbol	Test Conditions	Min	Typ.*	Max	Units
Supply Current, Dynamic <sup>[1]</sup>	I <sub>DDD</sub>	f <sub>CLOCK</sub> = 5 MHz		6.2	7.8	mA
Supply Current, Static <sup>[2]</sup>	I <sub>DDSoFF</sub>	V <sub>B</sub> = 0.4 V, Data and Clock = 0.4 V		1.8	26	mA
		V <sub>B</sub> = 2.4 V, Data and Clock = 0.4 V		2.2	6.0	
Column Input Current	I <sub>COL</sub>	V <sub>B</sub> = 0.4 V			10	μA
		V <sub>B</sub> = 2.4 V		500	650	mA
Input Logic High Data, V <sub>B</sub> , Clock	V <sub>IH</sub>	V <sub>DD</sub> = 4.75 V	2.0			V
Input Logic Low Data, V <sub>B</sub> , Clock	V <sub>IL</sub>	V <sub>DD</sub> = 5.25 V			0.8	V
Input Current	I <sub>I</sub>	V <sub>DD</sub> = 5.25 V				
		V <sub>I</sub> <sup>[3]</sup> = 2.4 V (Logic High) or V <sub>I</sub> <sup>[3]</sup> = 0.4 V (Logic Low)	–46 –92	–60 –120	–103 –206	μA
Data Out Voltage	V <sub>OH</sub>	V <sub>DD</sub> = 4.75 V I <sub>OH</sub> = –0.5 mA I <sub>COL</sub> = 0 mA	2.4	4.2		V
	V <sub>OL</sub>	V <sub>DD</sub> = 5.25 V I <sub>OL</sub> = 1.6 mA I <sub>COL</sub> = 0 mA		0.2	0.4	V
Power Dissipation Per Package <sup>[4]</sup>	P <sub>D</sub>	V <sub>DD</sub> = 5.0 V V <sub>COL</sub> = 3.5 V 17.5% DF V <sub>B</sub> = 2.4 V 15 LEDs ON per Character		668		mW
Thermal Resistance IC Junction-to-Pin <sup>[5]</sup>	R <sub>θJ-PIN</sub>			10		°C/W
Leak Rate					5x10 <sup>–8</sup>	cc/sec

\*All typical values specified at V<sub>DD</sub> = 5.0 V and T<sub>A</sub> = 25°C.

#### Notes:

- I<sub>DD</sub> Dynamic is the IC current while clocking column data through the on-board shift register at a clock frequency of 5 MHz, the display is not illuminated.
- I<sub>DD</sub> Static is the IC current after column data is loaded and not being clocked through the on-board shift register.
- V<sub>I</sub> represents the input voltage to an input pin.
- Four characters are illuminated with a typical ASCII character composed of 15 dots per character.
- IC junction temperature T<sub>J</sub> (IC) = (P<sub>D</sub>)(R<sub>θJ-PIN</sub> + R<sub>θPC-A</sub>) + T<sub>A</sub>.

**Optical Characteristics at  $T_A = 25^\circ\text{C}$**   
**High Performance Green HCMS-2353**

Description	Symbol	Test Condition	Min.	Typ.*	Max.	Units
Peak Luminous Intensity per LED [6] (Character Average)	$I_{VPEAK}$	$V_{DD} = 5.0\text{ V}$ $V_{COL} = 3.5\text{ V}$ $V_B = 2.4\text{ V}$ $T_i = 25^\circ\text{C}$ [7]	2400	3000		$\mu\text{cd}$
Dominant Wavelength[8,9]	$\lambda_d$			574		nm
Peak Wavelength	$\lambda_{PEAK}$			568		nm

**Yellow HCMS-2351**

Description	Symbol	Test Condition	Min	Typ.*	Max.	Units
Peak Luminous Intensity per LED [6] (Character Average)	$I_{VPEAK}$	$V_{DD} = 5.0\text{ V}$ $V_{COL} = 3.5\text{ V}$ $V_B = 2.4\text{ V}$ $T_i = 25^\circ\text{C}$ [7]	1600	2400		$\mu\text{cd}$
Dominant Wavelength [8,9]	$\lambda_d$			585		nm
Peak Wavelength	$\lambda_{PEAK}$			583		nm

\*All typical values specified at  $V_{DD} = 5.0\text{ V}$  and  $T_A = 25^\circ\text{C}$  unless otherwise noted.

**Notes:**

- These LED displays are categorized for luminous intensity, with the intensity category designated by a letter code on the back of the package.
- $T_i$  refers to the initial case temperature of the display immediately prior to the light measurement.
- Dominant wavelength,  $\lambda_d$ , is derived from the CIE Chromaticity Diagram, and represents the single wavelength which defines the color of the device.
- Categorized for color with the color category designated by a number on the back of the package.

**Switching Characteristics**

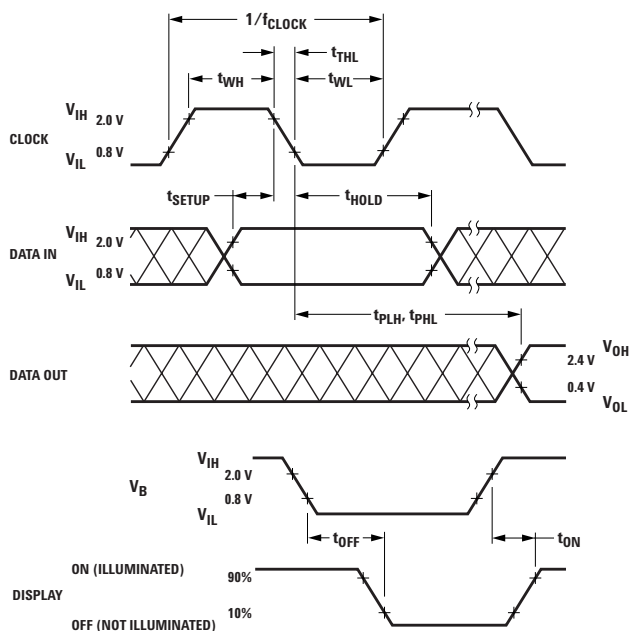

Parameter	Condition	Typ.	Max.	Units
$f_{clock}$	CLOCK Rate		5	MHz
$t_{PLH}, t_{PHL}$	$C_L = 15\text{ pF}$		105	ns
Propagation Delay	$R_L = 2.4\text{ k}\Omega$			
CLOCK to DATA OUT				
$t_{OFF}$	$V_B (0.4\text{ V})$ to Display OFF	4	5	$\mu\text{s}$
$t_{ON}$	$V_B (2.4\text{ V})$ to Display ON	1	2	

## Electrical Description

The display contains four 5 x 7 LED dot matrix characters and two CMOS integrated circuits, as shown in Figure 1. The two CMOS integrated circuits form an on-board 28 bit serial-in/parallel-out shift register that will accept standard TTL logic levels. The Data Input, pin 12, is connected to bit position 1 and the Data Output, pin 7, is connected to bit position 28. The shift register outputs control constant current sinking LED row drivers. A logic 1 stored in the shift register enables the corresponding LED row driver and a logic 0 stored in the shift register disables the corresponding LED row driver.

The electrical configuration of these CMOSIC alphanumeric displays allows for an effective interface to a display controller circuit that supplies decoded character information. The row data for a given column (one 7 bit byte per character) is loaded (bit serial) into the on-board 28 bit shift register with high to low transitions of the Clock input. To load

decoded character information into the display, column data for character 4 is loaded first and the column data for character 1 is loaded last in the following manner. The 7 data bits for column 1, character 4, are loaded into the on-board shift register. Next, the 7 data bits for column 1, character 3, are loaded into the shift register, shifting the character 4 data over one character position. This process is repeated for the other two characters until all 28 bits of column data (four 7 bit bytes of character column data) are loaded into the on-board shift register. Then the column 1 input,  $V_{COL}$  pin 1, is energized to illuminate column 1 in all four characters. This process is repeated for columns 2, 3, 4 and 5. All  $V_{COL}$  inputs should be at logic low to insure the display is off when loading data. The display will be blanked when the blanking input  $V_B$ , pin 8, is at logic low regardless of the outputs of the shift register or whether one of the  $V_{COL}$  inputs is energized. Refer to Application Note 1016 for drive circuit information.

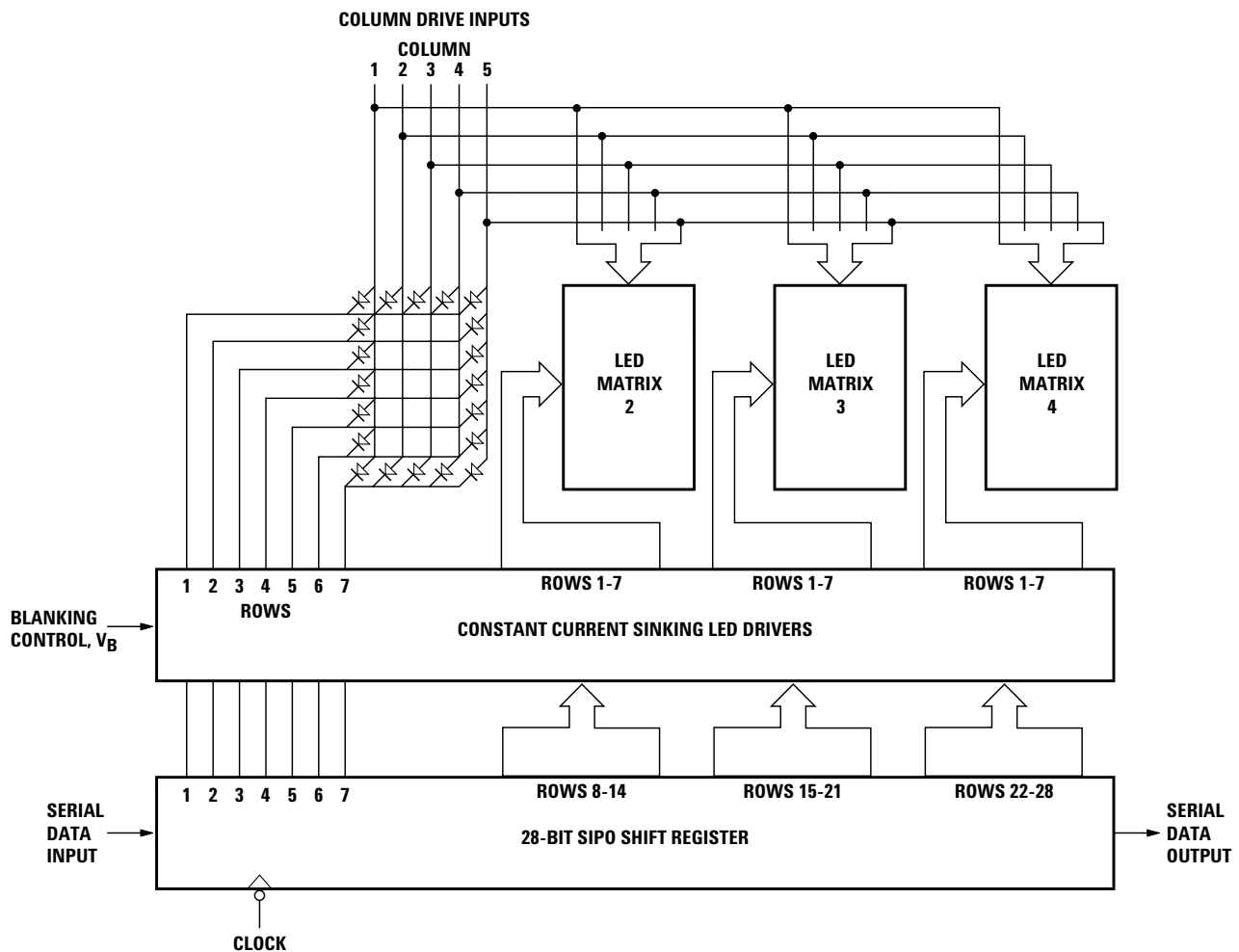

Figure 1. Display block diagram.

### ESD Susceptibility

The display has an ESD susceptibility ratings of CLASS 3 of MIL-STD-883E, HBM. It is recommended that normal CMOS handling precautions be observed with these devices.

### Soldering and Post Solder Cleaning

These displays may be soldered with a standard wave solder process using either an RMA flux and solvent cleaning or an OA flux and aqueous cleaning. For optimum soldering, the solder wave temperature should be 245 °C and the dwell time for any display lead passing through the wave should be 1.5 to 2 seconds. For more detailed information, refer to Application Note 1027, Soldering LED Components.

### Contrast Enhancement

When used with the proper contrast enhancement filters, the display is readable in sunlight.

Refer to Application Note 1029, Luminous Contrast and Sunlight Readability of the HDSP-235X Series Alpha-numeric Displays for Sunlight Viewable Applications, for information on contrast enhancement for sun-light and daylight ambient. Refer to Application Note 1015, Contrast Enhancement Techniques for LED Displays, for information on contrast enhancement in moderate ambients

### Night Vision Lighting

When used with the proper NVG/DV filters, HCMS-235x display may be used in night vision lighting applications. For a list of NVG/DV filters and a discussion on night vision lighting technology, refer to Application Note 1030, LED Displays and Indicators and Night Vision Imaging System Lighting.

### Controller Circuits, Power Calculations, and Display Dimming

Refer to Application Note 1016, Using the HDSP-2000 Alphanumeric Display Family, for information on controller circuits to drive these displays, how to do power calculations, and a technique for display dimming.

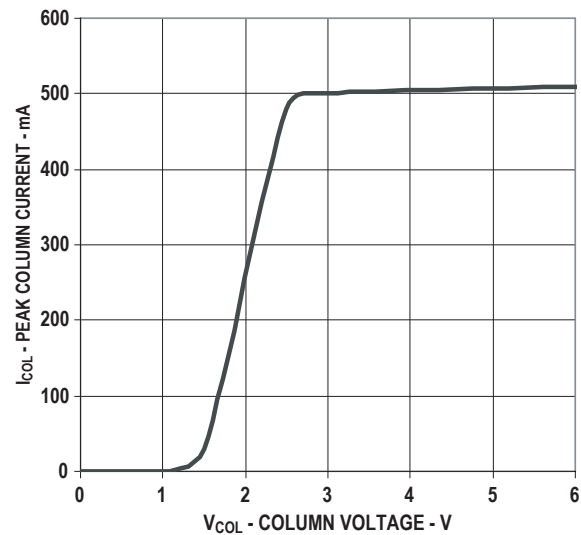

Figure 2. Peak column current vs. column voltage at T<sub>A</sub> = 25°C.

For product information and a complete list of distributors, please go to our web site: [www.avagotech.com](http://www.avagotech.com)

Avago, Avago Technologies, and the A logo are trademarks of Avago Technologies in the United States and other countries. Data subject to change. Copyright © 2005-2008 Avago Technologies. All rights reserved. Obsoletes 5989-3180EN AV02-0195EN - November 28, 2008



Компания «Life Electronics» занимается поставками электронных компонентов импортного и отечественного производства от производителей и со складов крупных дистрибьюторов Европы, Америки и Азии.

С конца 2013 года компания активно расширяет линейку поставок компонентов по направлению коаксиальный кабель, кварцевые генераторы и конденсаторы (керамические, пленочные, электролитические), за счёт заключения дистрибьюторских договоров

Мы предлагаем:

- Конкурентоспособные цены и скидки постоянным клиентам.
- Специальные условия для постоянных клиентов.
- Подбор аналогов.
- Поставку компонентов в любых объемах, удовлетворяющих вашим потребностям.
- Приемлемые сроки поставки, возможна ускоренная поставка.
- Доставку товара в любую точку России и стран СНГ.
- Комплексную поставку.
- Работу по проектам и поставку образцов.
- Формирование склада под заказчика.
- Сертификаты соответствия на поставляемую продукцию (по желанию клиента).
- Тестирование поставляемой продукции.
- Поставку компонентов, требующих военную и космическую приемку.
- Входной контроль качества.
- Наличие сертификата ISO.

В составе нашей компании организован Конструкторский отдел, призванный помогать разработчикам, и инженерам.

Конструкторский отдел помогает осуществить:

- Регистрацию проекта у производителя компонентов.
- Техническую поддержку проекта.
- Защиту от снятия компонента с производства.
- Оценку стоимости проекта по компонентам.
- Изготовление тестовой платы монтаж и пусконаладочные работы.



Тел: +7 (812) 336 43 04 (многоканальный)

Email: [org@lifeelectronics.ru](mailto:org@lifeelectronics.ru)