

N-channel 600 V, 0.160 Ω typ., 19 A MDmesh™ II Power MOSFET in a PowerFLAT 8x8 HV package

Datasheet - production data

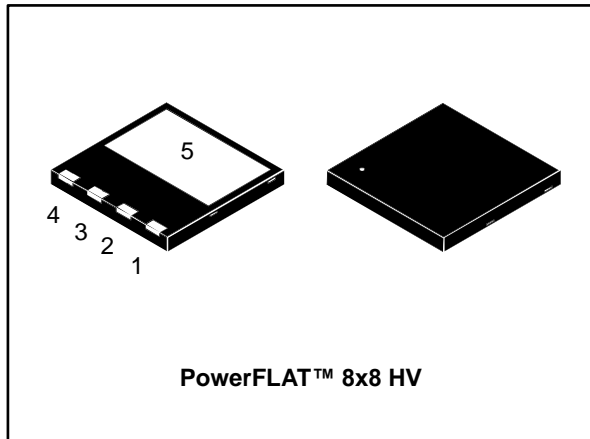

Figure 1: Internal schematic diagram

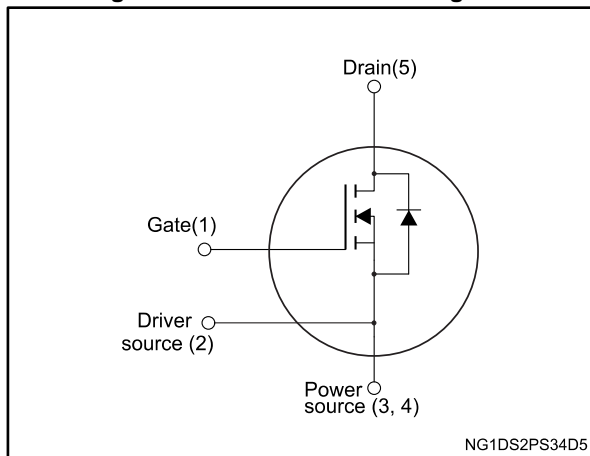

Table 1: Device summary

Order code	Marking	Package	Packaging
STL26NM60N	26NM60N	PowerFLAT™ 8x8 HV	Tape and reel

Features

Order code	V _{DS}	R _{DS(on)} max	I _D
STL26NM60N	600 V	0.185 Ω	19 A

- 100% avalanche tested
- Low input capacitance and gate charge
- Low gate input resistance

Applications

- Switching applications

Description

This device is an N-channel Power MOSFET developed using the second generation of MDmesh™ technology. This revolutionary Power MOSFET associates a vertical structure to the company's strip layout to yield one of the world's lowest on-resistance and gate charge. It is therefore suitable for the most demanding high efficiency converters.

Contents

1	Electrical ratings	3
2	Electrical characteristics	4
	2.1 Electrical characteristics (curves)	6
3	Test circuits	8
4	Package information	9
	4.1 PowerFLAT 8x8 HV package information	10
	4.2 PowerFLAT 8x8 HV packing information	12
5	Revision history	14

1 Electrical ratings

Table 2: Absolute maximum ratings

Symbol	Parameter	Value	Unit
V_{DS}	Drain-source voltage	600	V
V_{GS}	Gate-source voltage	± 30	V
I_D	Drain current (continuous) at $T_C = 25\text{ }^\circ\text{C}$	19	A
I_D	Drain current (continuous) at $T_C = 100\text{ }^\circ\text{C}$	12	A
$I_{DM}^{(1)}$	Drain current (pulsed)	76	A
P_{TOT}	Total dissipation at $T_C = 25\text{ }^\circ\text{C}$	125	W
$dv/dt^{(2)}$	Peak diode recovery voltage slope	15	V/ns
T_{stg}	Storage temperature range	-55 to 150	$^\circ\text{C}$
T_j	Operating junction temperature range		

Notes:

(1)Pulse width limited by safe operating area.

(2) $I_{SD} \leq 19\text{ A}$, $di/dt \leq 400\text{ A}/\mu\text{s}$, $V_{DS(\text{peak})} \leq V_{(BR)DSS}$, $V_{DD} \leq 80\% V_{(BR)DSS}$

Table 3: Thermal data

Symbol	Parameter	Value	Unit
$R_{thj\text{-case}}$	Thermal resistance junction-case	1	$^\circ\text{C}/\text{W}$
$R_{thj\text{-amb}}^{(1)}$	Thermal resistance junction-ambient	45	$^\circ\text{C}/\text{W}$

Notes:

(1)When mounted on 1inch² FR-4 board, 2 oz Cu.

Table 4: Avalanche characteristics

Symbol	Parameter	Value	Unit
I_{AS}	Single pulse avalanche current (pulse width limited by $T_{j\text{max}}$)	6	A
E_{AS}	Single pulse avalanche energy (starting $T_J=25\text{ }^\circ\text{C}$, $I_D=I_{AS}$, $V_{DD}=50\text{ V}$)	400	mJ

2 Electrical characteristics

(T_{CASE} = 25 °C unless otherwise specified)

Table 5: On/off states

Symbol	Parameter	Test conditions	Min.	Typ.	Max.	Unit
V _{(BR)DSS}	Drain-source breakdown voltage	I _D = 1 mA, V _{GS} = 0 V	600			V
I _{DSS}	Zero gate voltage drain current	V _{GS} = 0 V, V _{DS} = 600 V			1	μA
		V _{GS} = 0 V, V _{DS} = 600 V, T _C = 125 °C ⁽¹⁾			100	
I _{GSS}	Gate-body leakage current	V _{DS} = 0 V, V _{GS} = ±25 V			±0.1	μA
V _{GS(th)}	Gate threshold voltage	V _{DS} = V _{GS} , I _D = 250 μA	3	4	5	V
R _{DS(on)}	Static drain-source on-resistance	V _{GS} = 10 V, I _D = 10 A		0.160	0.185	Ω

Notes:

⁽¹⁾Defined by design, not subject to production test.

Table 6: Dynamic

Symbol	Parameter	Test conditions	Min.	Typ.	Max.	Unit
C _{iss}	Input capacitance	V _{DS} = 50 V, f = 1 MHz, V _{GS} = 0 V	-	1800	-	pF
C _{oss}	Output capacitance		-	115	-	pF
C _{rss}	Reverse transfer capacitance		-	6	-	pF
C _{oss eq.} ⁽¹⁾	Equivalent output capacitance	V _{GS} = 0 V, V _{DS} = 0 to 480 V	-	310	-	pF
Q _g	Total gate charge	V _{DD} = 480 V, I _D = 19 A, V _{GS} = 10 V (see Figure 14: "Gate charge test circuit")	-	60	-	nC
Q _{gs}	Gate-source charge		-	8.5	-	nC
Q _{gd}	Gate-drain charge		-	30	-	nC
R _G	Gate input resistance	f=1 MHz, I _D =0 A	-	2.8	-	Ω

Notes:

⁽¹⁾C_{oss eq.} is defined as a constant equivalent capacitance giving the same charging time as C_{oss} when V_{DS} increases from 0 to 80% V_{DS}

Table 7: Switching times

Symbol	Parameter	Test conditions	Min.	Typ.	Max.	Unit
t _{d(on)}	Turn-on delay time	V _{DD} = 300 V, I _D = 10 A, R _G = 4.7 Ω, V _{GS} = 10 V (see Figure 13: "Switching times test circuit for resistive load" and Figure 18: "Switching time waveform")	-	13	-	ns
t _r	Rise time		-	25	-	ns
t _{d(off)}	Turn-off delay time		-	85	-	ns
t _f	Fall time		-	50	-	ns

Table 8: Source-drain diode

Symbol	Parameter	Test conditions	Min.	Typ.	Max.	Unit
I_{SD}	Source-drain current		-		19	A
$I_{SDM}^{(1)}$	Source-drain current (pulsed)		-		76	A
$V_{SD}^{(2)}$	Forward on voltage	$I_{SD} = 19\text{ A}$, $V_{GS} = 0\text{ V}$	-		1.5	V
t_{rr}	Reverse recovery time	$I_{SD} = 19\text{ A}$, $di/dt = 100\text{ A}/\mu\text{s}$	-	370		ns
Q_{rr}	Reverse recovery charge	$V_{DD} = 100\text{ V}$	-	5.8		μC
I_{RRM}	Reverse recovery current	(see <i>Figure 15: "Test circuit for inductive load switching and diode recovery times"</i>)	-	31.6		A
t_{rr}	Reverse recovery time	$I_{SD} = 19\text{ A}$, $di/dt = 100\text{ A}/\mu\text{s}$	-	450		ns
Q_{rr}	Reverse recovery charge	$V_{DD} = 100\text{ V}$, $T_J = 150\text{ }^\circ\text{C}$	-	7.5		μC
I_{RRM}	Reverse recovery current	(see <i>Figure 15: "Test circuit for inductive load switching and diode recovery times"</i>)	-	32.5		A

Notes:

(1) Pulse width limited by safe operating area.

(2) Pulsed: pulse duration = 300 μs , duty cycle 1.5%

2.1 Electrical characteristics (curves)

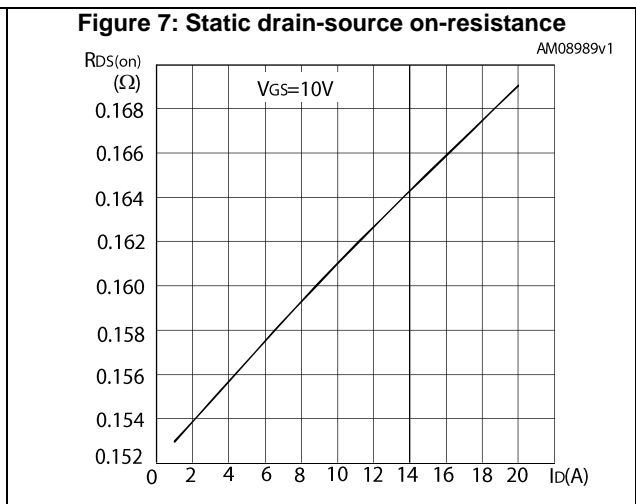
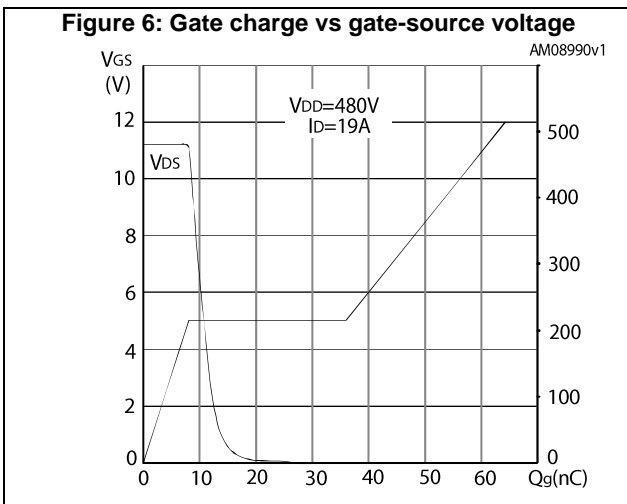
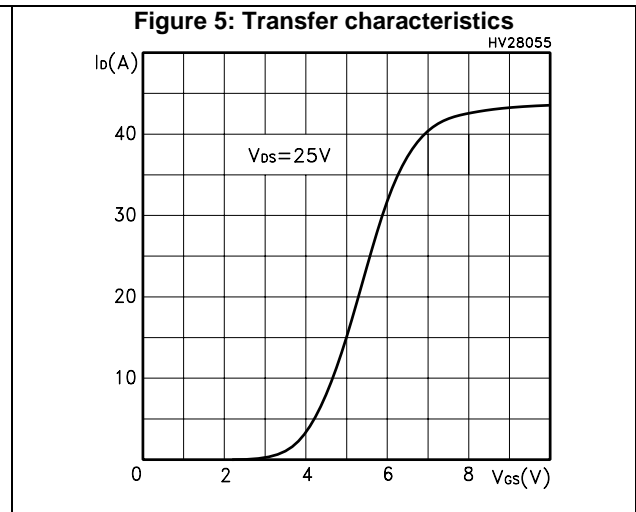
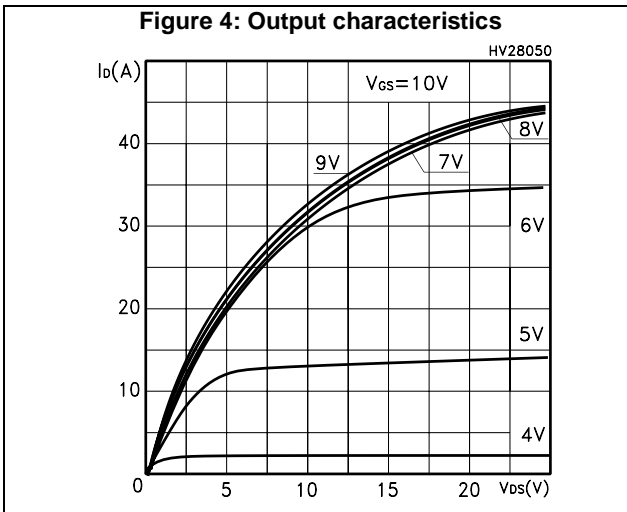
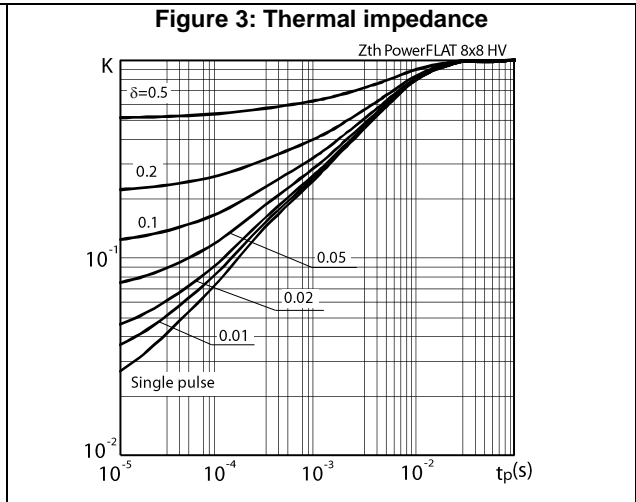
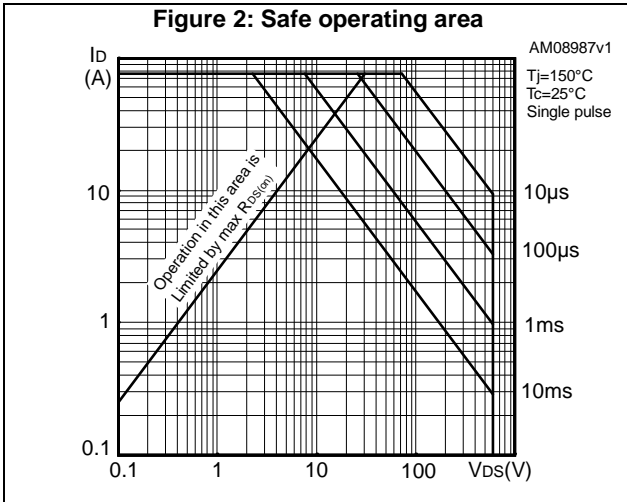

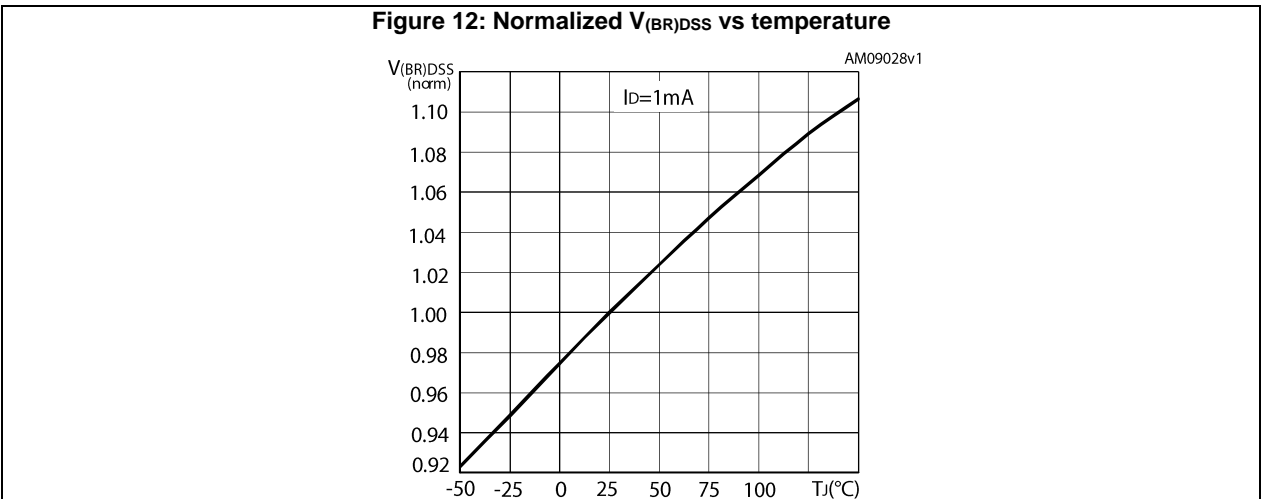
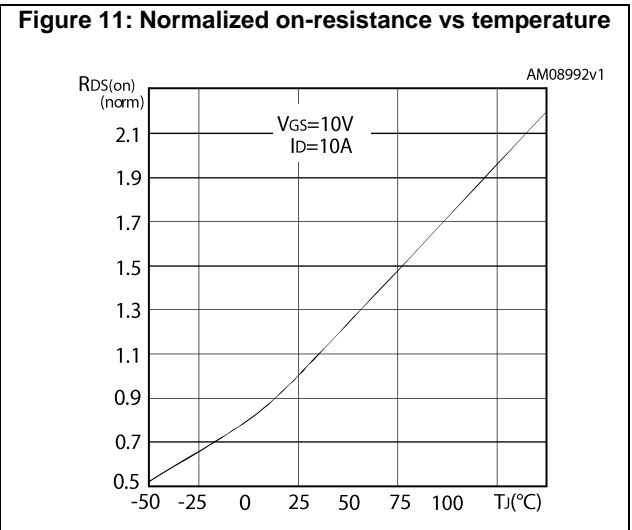
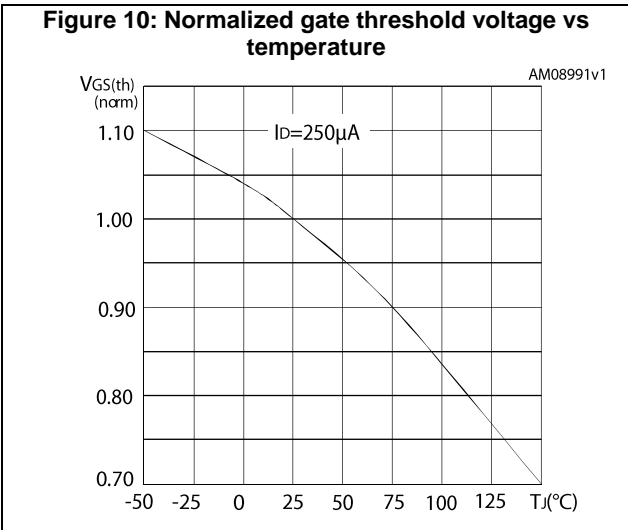
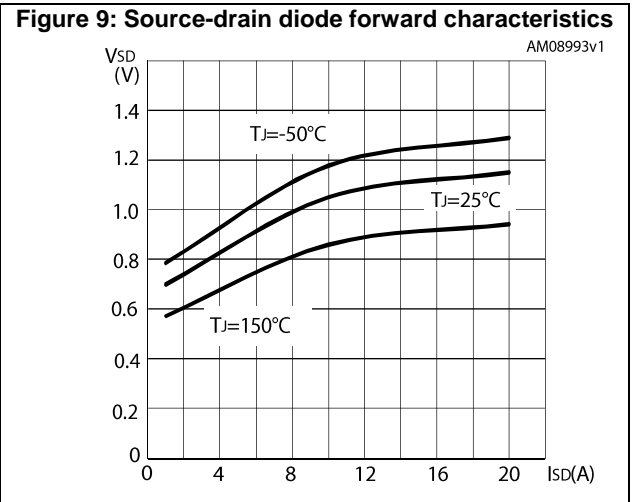
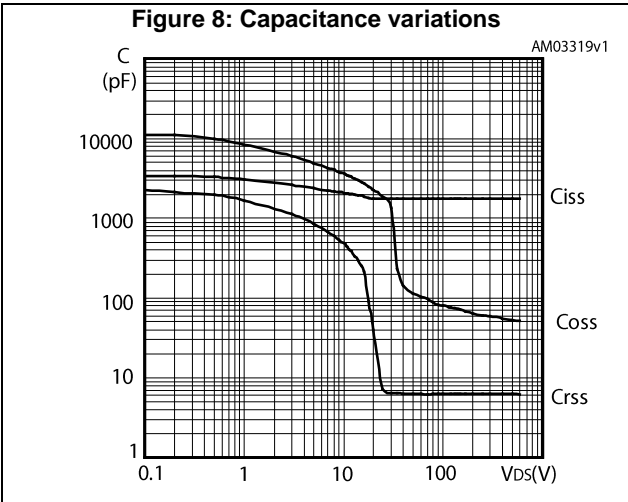

3 Test circuits

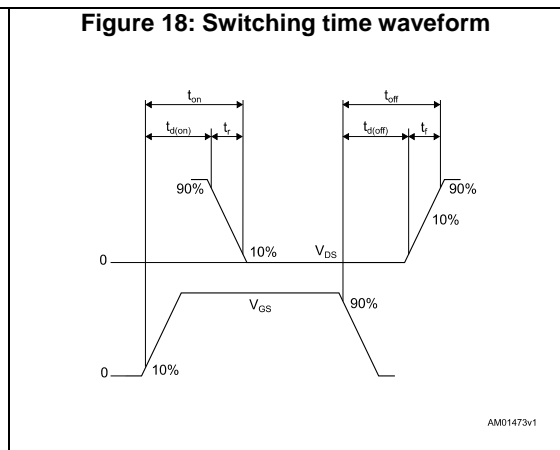
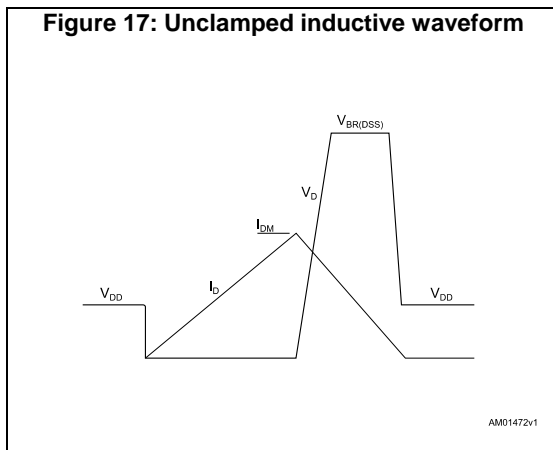
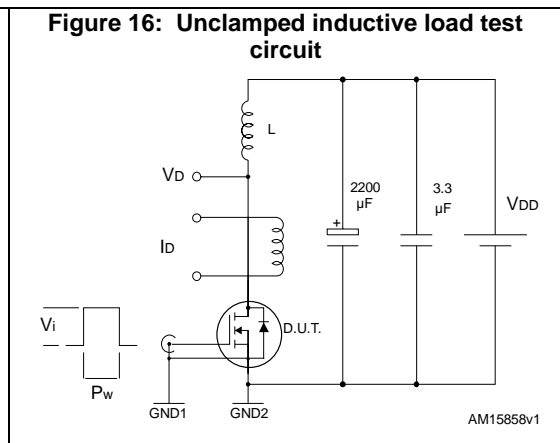
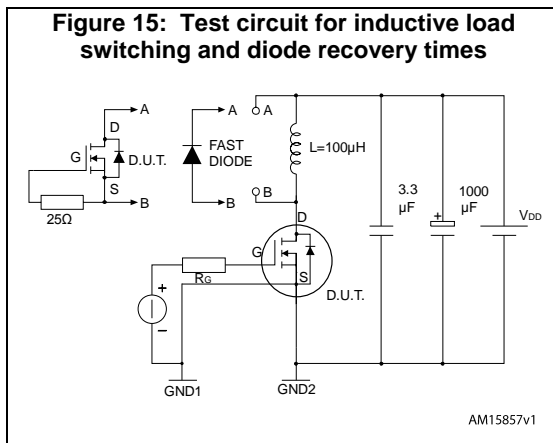
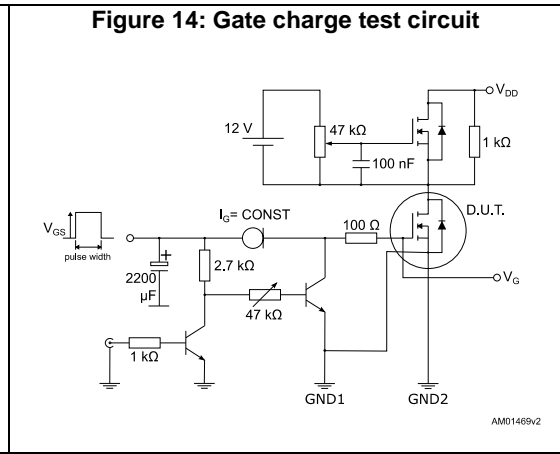
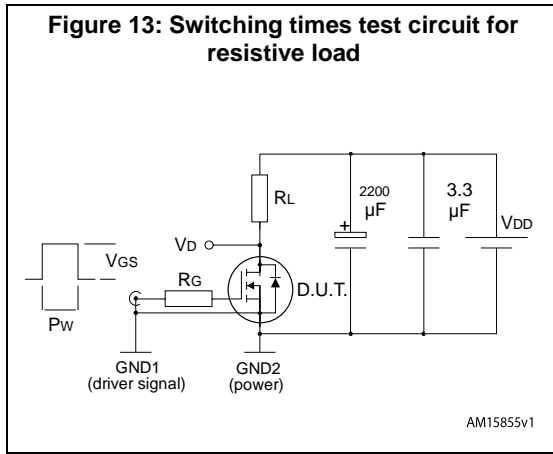

4 Package information

In order to meet environmental requirements, ST offers these devices in different grades of ECOPACK® packages, depending on their level of environmental compliance. ECOPACK® specifications, grade definitions and product status are available at: www.st.com. ECOPACK® is an ST trademark.

4.1 PowerFLAT 8x8 HV package information

Figure 19: PowerFLAT™ 8x8 HV package outline

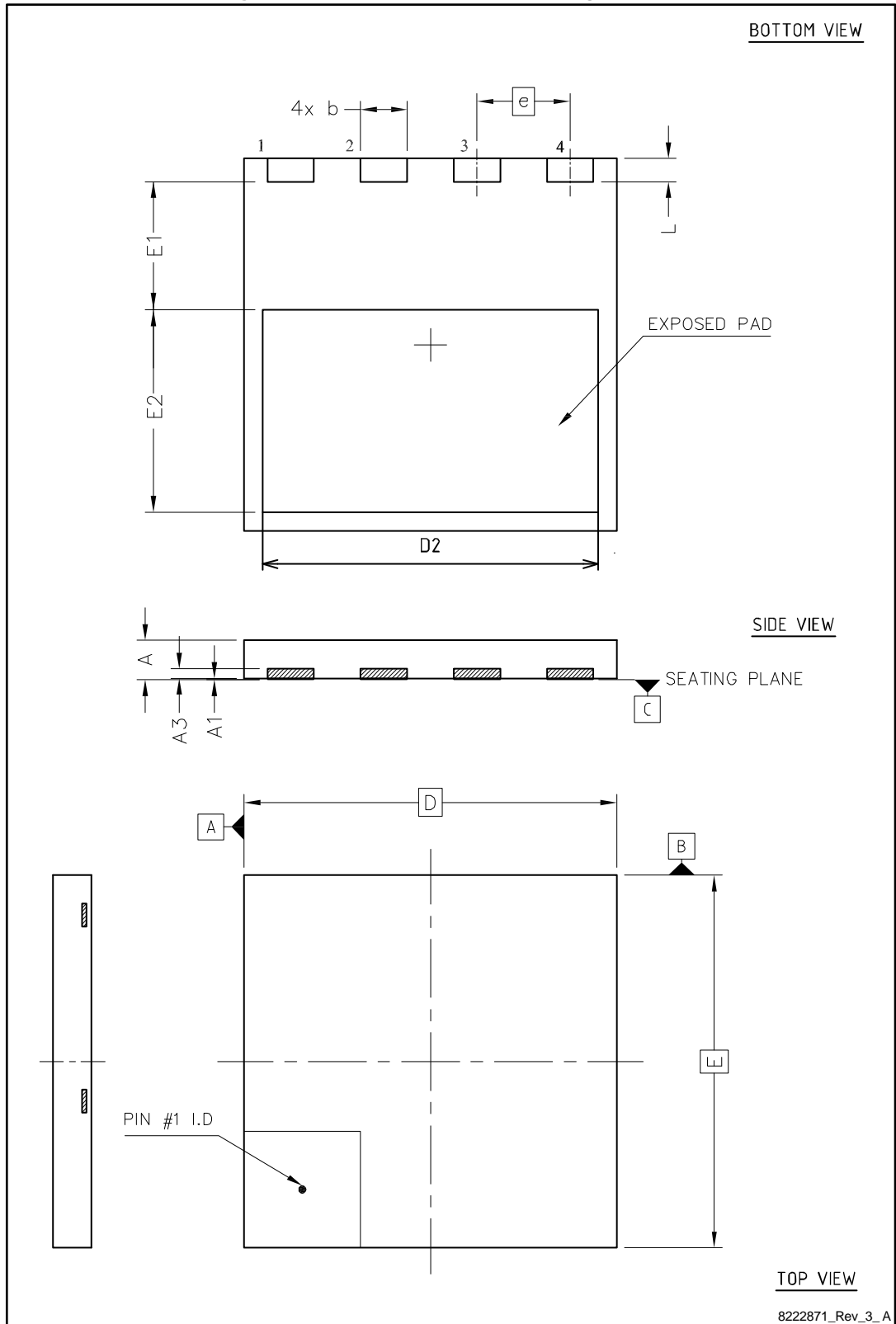

8222871_Rev_3_A

Table 9: PowerFLAT™ 8x8 HV mechanical data

Dim.	mm		
	Min.	Typ.	Max.
A	0.75	0.85	0.95
A1	0.00		0.05
A3	0.10	0.20	0.30
b	0.90	1.00	1.10
D	7.90	8.00	8.10
E	7.90	8.00	8.10
D2	7.10	7.20	7.30
E1	2.65	2.75	2.85
E2	4.25	4.35	4.45
e		2.00	
L	0.40	0.50	0.60

Figure 20: PowerFLAT™ 8x8 HV footprint

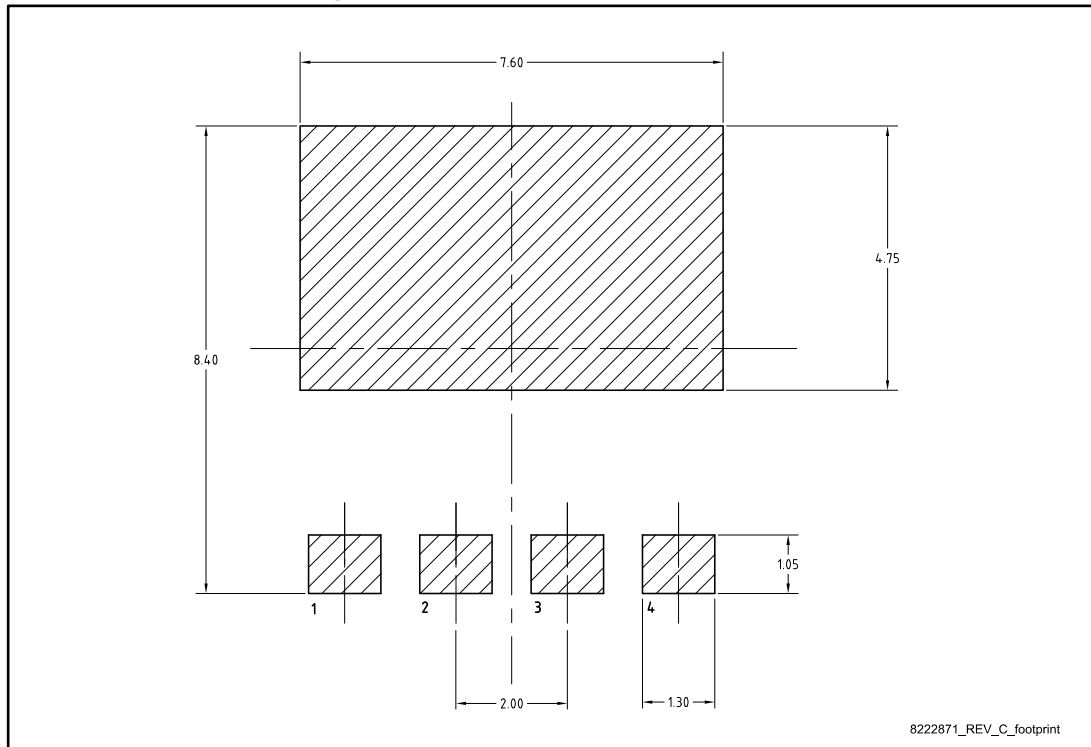

All dimensions are in millimeters.

4.2 PowerFLAT 8x8 HV packing information

Figure 21: PowerFLAT™ 8x8 HV tape

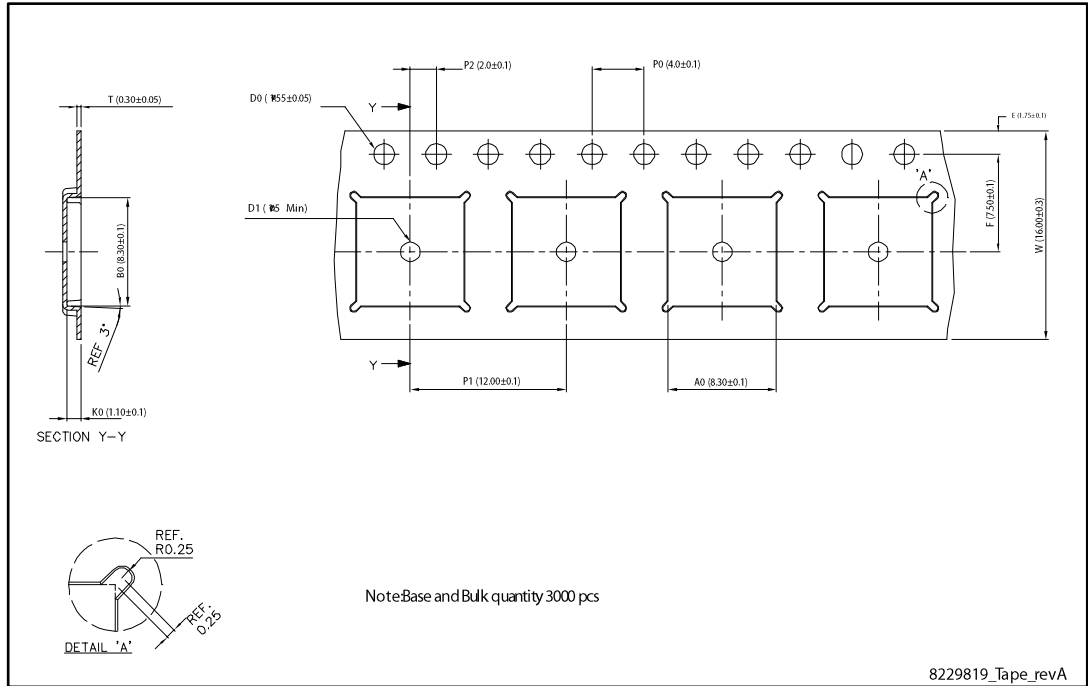

All dimensions are in millimeters.

Figure 22: PowerFLAT™ 8x8 HV package orientation in carrier tape

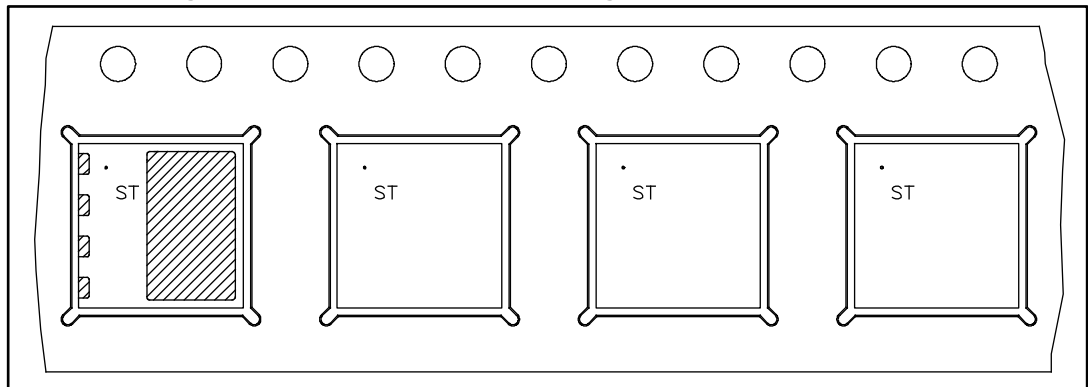
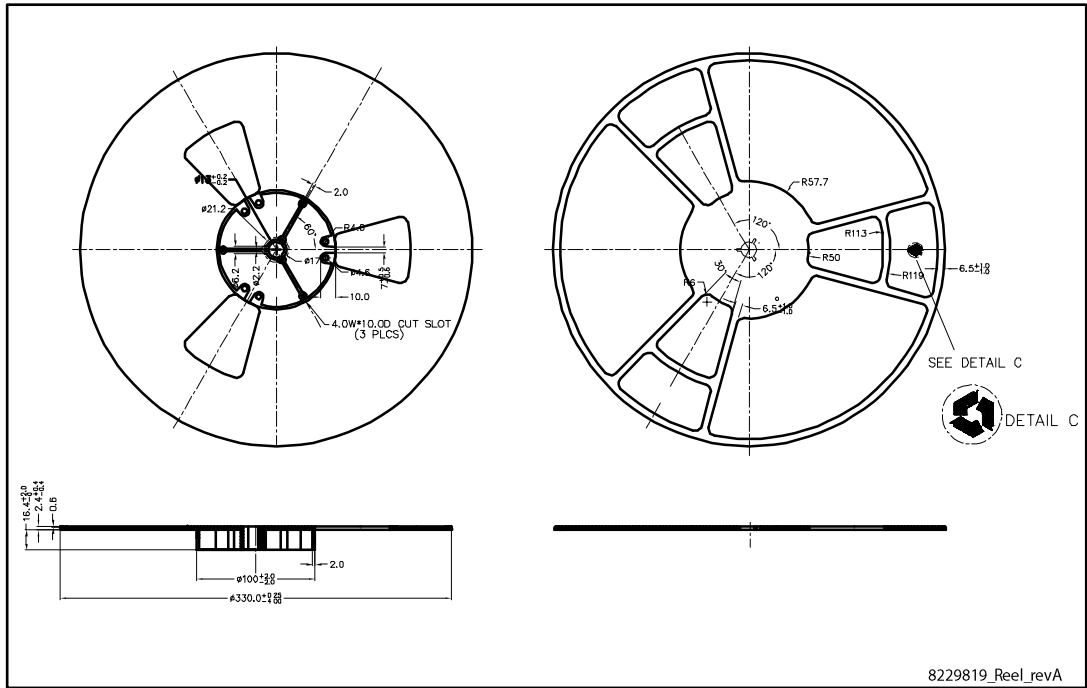

Figure 23: PowerFLAT™ 8x8 HV reel



All dimensions are in millimeters.

5 Revision history

Table 10: Document revision history

Date	Revision	Changes
14-Feb-2011	1	First release.
03-Nov-2011	2	<i>Section 4: Package mechanical data</i> has been updated. Minor text changes.
14-Dec-2016	3	Updated title, silhouette, features, description and internal schematic diagram on cover page. Modified <i>Table 2: "Absolute maximum ratings"</i> , <i>Table 3: "Thermal data"</i> , <i>Table 5: "On/off states"</i> , <i>Table 6: "Dynamic"</i> , <i>Table 7: "Switching times"</i> and <i>Table 8: "Source-drain diode"</i> . Minor text changes.

IMPORTANT NOTICE – PLEASE READ CAREFULLY

STMicroelectronics NV and its subsidiaries ("ST") reserve the right to make changes, corrections, enhancements, modifications, and improvements to ST products and/or to this document at any time without notice. Purchasers should obtain the latest relevant information on ST products before placing orders. ST products are sold pursuant to ST's terms and conditions of sale in place at the time of order acknowledgement.

Purchasers are solely responsible for the choice, selection, and use of ST products and ST assumes no liability for application assistance or the design of Purchasers' products.

No license, express or implied, to any intellectual property right is granted by ST herein.

Resale of ST products with provisions different from the information set forth herein shall void any warranty granted by ST for such product.

ST and the ST logo are trademarks of ST. All other product or service names are the property of their respective owners.

Information in this document supersedes and replaces information previously supplied in any prior versions of this document.

© 2016 STMicroelectronics – All rights reserved

Компания «Life Electronics» занимается поставками электронных компонентов импортного и отечественного производства от производителей и со складов крупных дистрибьюторов Европы, Америки и Азии.

С конца 2013 года компания активно расширяет линейку поставок компонентов по направлению коаксиальный кабель, кварцевые генераторы и конденсаторы (керамические, пленочные, электролитические), за счёт заключения дистрибьюторских договоров

Мы предлагаем:

- Конкурентоспособные цены и скидки постоянным клиентам.
- Специальные условия для постоянных клиентов.
- Подбор аналогов.
- Поставку компонентов в любых объемах, удовлетворяющих вашим потребностям.
- Приемлемые сроки поставки, возможна ускоренная поставка.
- Доставку товара в любую точку России и стран СНГ.
- Комплексную поставку.
- Работу по проектам и поставку образцов.
- Формирование склада под заказчика.
- Сертификаты соответствия на поставляемую продукцию (по желанию клиента).
- Тестирование поставляемой продукции.
- Поставку компонентов, требующих военную и космическую приемку.
- Входной контроль качества.
- Наличие сертификата ISO.

В составе нашей компании организован Конструкторский отдел, призванный помогать разработчикам, и инженерам.

Конструкторский отдел помогает осуществить:

- Регистрацию проекта у производителя компонентов.
- Техническую поддержку проекта.
- Защиту от снятия компонента с производства.
- Оценку стоимости проекта по компонентам.
- Изготовление тестовой платы монтаж и пусконаладочные работы.



Тел: +7 (812) 336 43 04 (многоканальный)
Email: org@lifeelectronics.ru