



Industrial USB Plugs and Receptacles

- 84727** Plug, Type-A
- 84728** Plug, Type-B
- 84729** Receptacle, Type-A
- 84730** Receptacle, Type-B
- 84732** Double-Ended Cordset



Top, Left to right: Double-Ended Cordset, USB Type-B Plug to Type-A Plug (84732)

Bottom: USB Type-B Panel Mount PCB Receptacle (84730)

Industrial USB connectors bring one of the most popular and convenient I/O connectors into harsh commercial and industrial environments

Molex's sealed, industrial Universal Serial Bus (USB) connectors are ideal for industrial and harsh commercial applications, where a secure and robust connection is required. The rugged, plug and receptacle designs feature bayonet-style latches, encapsulated PCB receptacles and overmolded cable assemblies to help keep out dust, debris and water.

Many industrial devices and networks use a direct interface to a PC for programming, monitoring, data collection and diagnostics of the industrial bus. USB connectors are ideal for both short-term diagnostics that require simple and fast setup, and permanent

installations for data acquisition systems. Once software has been installed, USB plugs and receptacles can be quickly connected and disconnected from various devices without having to turn off computers or equipment.

High performance results and ease-of-use make industrial USB from Molex a valuable solution for a variety of harsh environment applications.

For more information on Industrial USB Plugs and Receptacles, please visit: www.molex.com/product/industrialusb.html.

Features and Benefits

- IP 67 and NEMA 6P ratings ensure cordsets are water and dust tight for functional integrity
- Overmolded cordsets allow for faster installation at customer site versus field-wireable designs
- Bayonet-style latch receptacle provides quick and easy connection and ensures proper insertion depth with mating
- Cordsets available in varied lengths up to 5.00m (16.40') which allows customers to choose the length convenient for their specific application
- Fully shielded cable provides Electro Magnetic Interference/Radio Frequency Interference (EMI/RFI) protection

SPECIFICATIONS

Reference Information

Packaging: Bag

Mates with: 84727 mates with 84729

84728 mates with 84730

84732 mates with 84729/84730

Minimum Order Qty.: 10

Standard Pack Size: 1

Electrical

Voltage: 30V

Current: 1.0A

Contact Resistance: 30 milliohms max.

Dielectric Withstanding Voltage: 750V AC

Insulation Resistance: 1000 Megohms min.

Mechanical

Lock Nut Destructive Torque:

2.71 Nm (24.0 in. lb) min.

Coupling Ring Destructive Torque:

2.26 Nm (20.0 in. lb) min.

Mating Force: 35N (7.87 lbf) max.

Withdrawal Force: 10N (2.25 lbf) min.

Durability: 1000 mating cycles

Physical

Receptacle Housing: PBT, Black

Overmolding: PVC, Black

Contact: Copper Alloy

Plating: Contact Area - 0.75µm (30µ") Gold (Au)
Screw - Nickel

Gasket Seal: Nitrile, Black

Coupling Ring: PBT, Black

Lock Nut: PBT, Black

Screw: Brass

Dust Cap: PBT, Black

Tether: PP or PE, Black

Operating Temperature: 0 to +70°C

RoHS Compliant: Yes

Flammability: UL 94V-0

Performance: USB 2.0

Industrial Seal Rating: NEMA 6P and IP 67

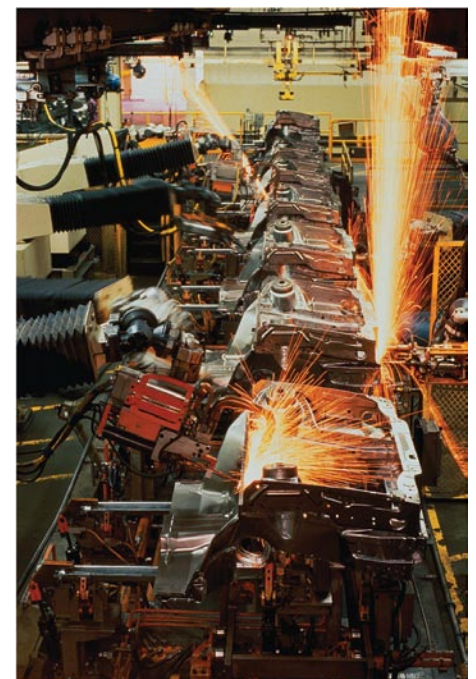

APPLICATIONS



Industrial USB Plugs and Receptacles

- Factory Automation
 - Industrial Computers
 - Industrial Controllers
 - Factory Peripherals
 - Printers
 - Barcode Scanners
- Robotics
- Vision Systems
- Motion and Process Controls
- Test and Measurement Equipment
- Medical Devices
- Factory Networking Installations
- Production Equipment



Test and Measurement Equipment

- 84727** Plug, Type-A
- 84728** Plug, Type-B
- 84729** Receptacle, Type-A
- 84730** Receptacle, Type-B
- 84732** Double-Ended Cordset

ORDERING INFORMATION

USB Plug, Shielded Pigtail

USB Type-A Order No.	USB Type-B Order No.	Length
84727-1002	84728-1002	1.50m (4.921')
84727-1001	84728-1001	2.00m (6.561')
84727-1003	84728-1003	3.00m (9.842')
84727-1004	84728-1004	5.00m (16.404')
84727-1005	84728-1005	0.15m (.492')

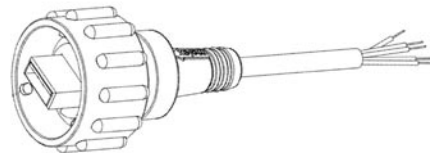

USB Type-A Plug to Pigtail

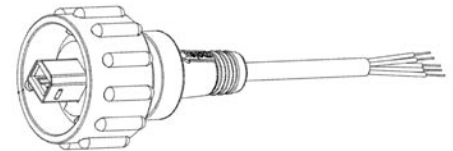

USB Type-B Plug to Pigtail

USB Type-A Panel Mount Receptacle to Standard USB Type-A Plug Cordset

Order No.	Length
84729-0003	0.152m (.498')
84729-0004	0.80m (2.624')
84729-0005	1.50m (4.921')
84729-0006	2.00m (6.561')
84729-0007	3.00m (9.842')
84729-0008	5.00m (16.404')

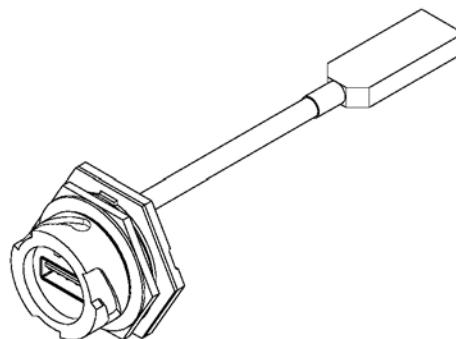

USB Type-A Panel Mount Receptacle to Standard USB Type-A Plug Cordset (Series 84729)



Industrial USB Plugs and Receptacles

- 84727** Plug, Type-A
- 84728** Plug, Type-B
- 84729** Receptacle, Type-A
- 84730** Receptacle, Type-B
- 84732** Double-Ended Cordset

USB Panel Mount PCB Receptacle

Order No.	USB Type
84729-0009	A
84730-0001	B

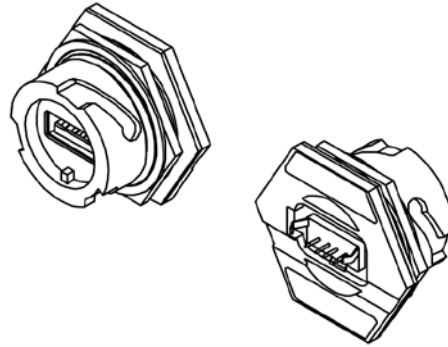

USB Type-A Panel Mount Receptacles with PCB tails (Series 84729)

USB Type-A Panel Mount Receptacle, 5-Circuit Pigtail

Order No.	Length
84729-0001	0.152m (.498')

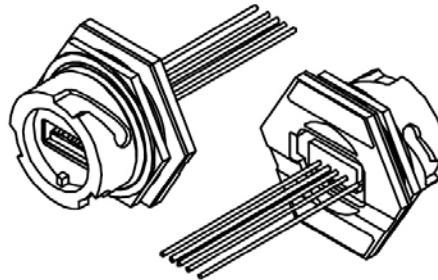

USB Type-A Panel Mount Receptacles to 5-Circuit Pigtail (Series 84729)

USB Type-A Plug to USB Type-B Plug, Double-Ended Cordset

Order No.	Length
84732-0001	0.80m (2.624')
84732-0002	1.50m (4.921')
84732-0003	2.00m (6.561')
84732-0004	3.00m (9.842')
84732-0005	5.00m (16.404')

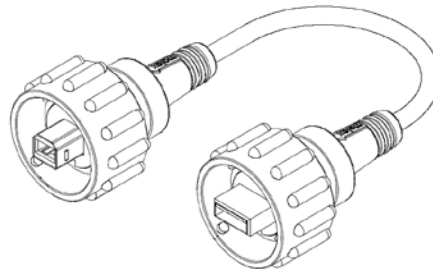

USB Type-B Plug to USB Type-A Plug Double-Ended Cordset (Series 84732)

Assembly Dust Cover

Order No.
84700-0003

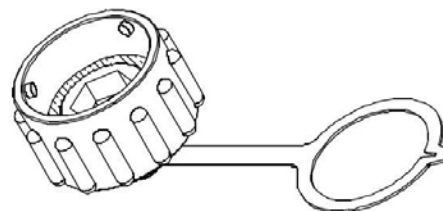

Dust Cover (Series 84700)

Americas Headquarters
 Lisle, Illinois 60532 U.S.A.
 1-800-78MOLEX
 amerinfo@molex.com

Asia Pacific North Headquarters
 Yamato, Kanagawa, Japan
 81-462-65-2324
 feninfo@molex.com

Asia Pacific South Headquarters
 Jurong, Singapore
 65-6268-6868
 fesinfo@molex.com

European Headquarters
 Munich, Germany
 49-89-413092-0
 eurinfo@molex.com

Corporate Headquarters
 2222 Wellington Ct.
 Lisle, IL 60532 U.S.A.
 630-969-4550
 Fax: 630-969-1352

Visit our website at www.molex.com/product/industrialusb.html

Компания «Life Electronics» занимается поставками электронных компонентов импортного и отечественного производства от производителей и со складов крупных дистрибьюторов Европы, Америки и Азии.

С конца 2013 года компания активно расширяет линейку поставок компонентов по направлению коаксиальный кабель, кварцевые генераторы и конденсаторы (керамические, пленочные, электролитические), за счёт заключения дистрибьюторских договоров

Мы предлагаем:

- Конкурентоспособные цены и скидки постоянным клиентам.
- Специальные условия для постоянных клиентов.
- Подбор аналогов.
- Поставку компонентов в любых объемах, удовлетворяющих вашим потребностям.
- Приемлемые сроки поставки, возможна ускоренная поставка.
- Доставку товара в любую точку России и стран СНГ.
- Комплексную поставку.
- Работу по проектам и поставку образцов.
- Формирование склада под заказчика.
- Сертификаты соответствия на поставляемую продукцию (по желанию клиента).
- Тестирование поставляемой продукции.
- Поставку компонентов, требующих военную и космическую приемку.
- Входной контроль качества.
- Наличие сертификата ISO.

В составе нашей компании организован Конструкторский отдел, призванный помогать разработчикам, и инженерам.

Конструкторский отдел помогает осуществить:

- Регистрацию проекта у производителя компонентов.
- Техническую поддержку проекта.
- Защиту от снятия компонента с производства.
- Оценку стоимости проекта по компонентам.
- Изготовление тестовой платы монтаж и пусконаладочные работы.



Тел: +7 (812) 336 43 04 (многоканальный)

Email: org@lifeelectronics.ru