

4

3

2

1

THIS DRAWING IS UNPUBLISHED. RELEASED FOR PUBLICATION .19 .
 © COPYRIGHT 19 BY AMP INCORPORATED. ALL RIGHTS RESERVED.

LOC		DIST		REVISIONS					
DY		-		P	LTR	DESCRIPTION	DATE	DWN	APVD
				B		REVISED PER ECO-17-005566	09MAR2017	B. J	S. Y

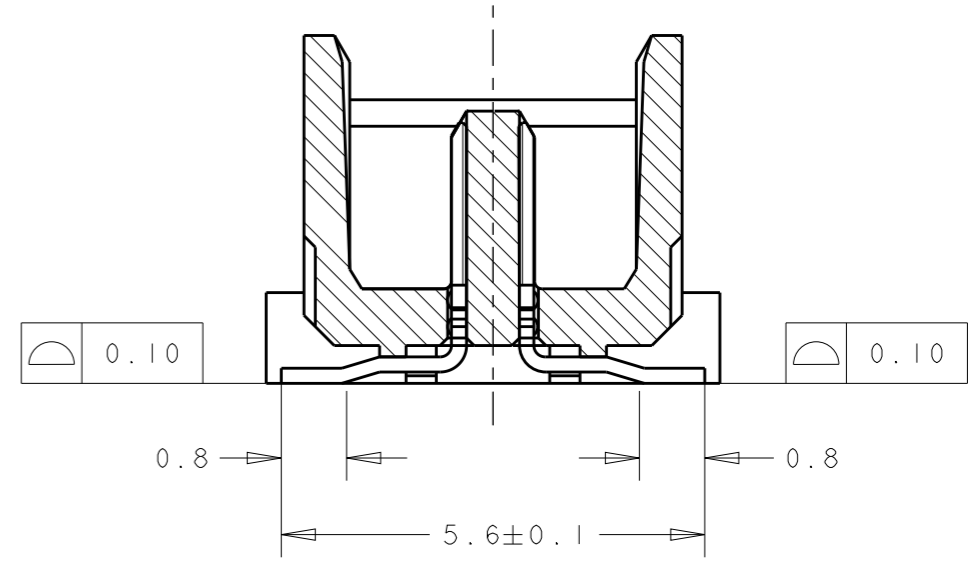
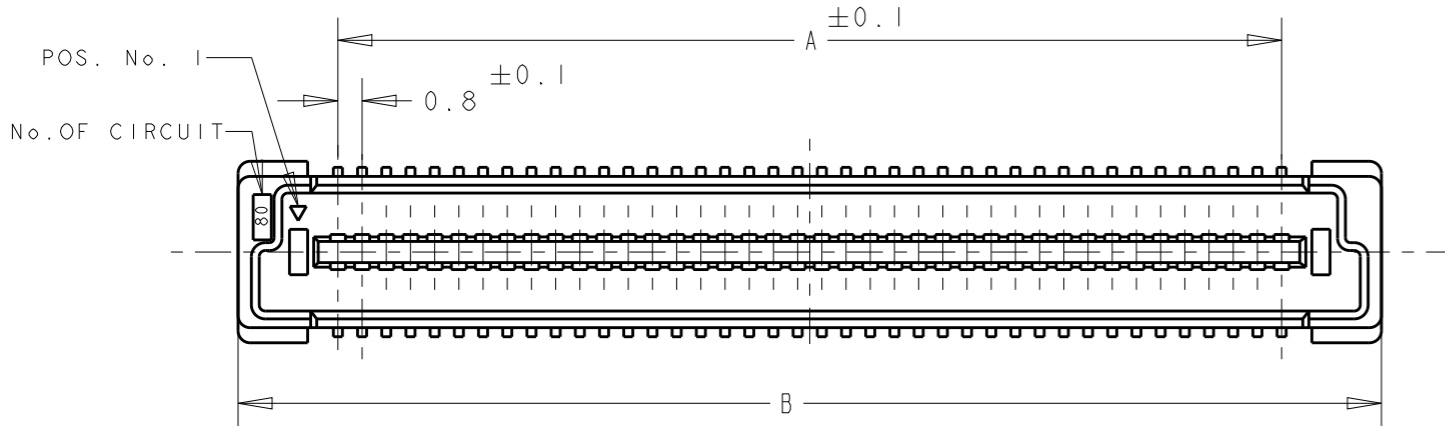

SECT. "A" - "A"

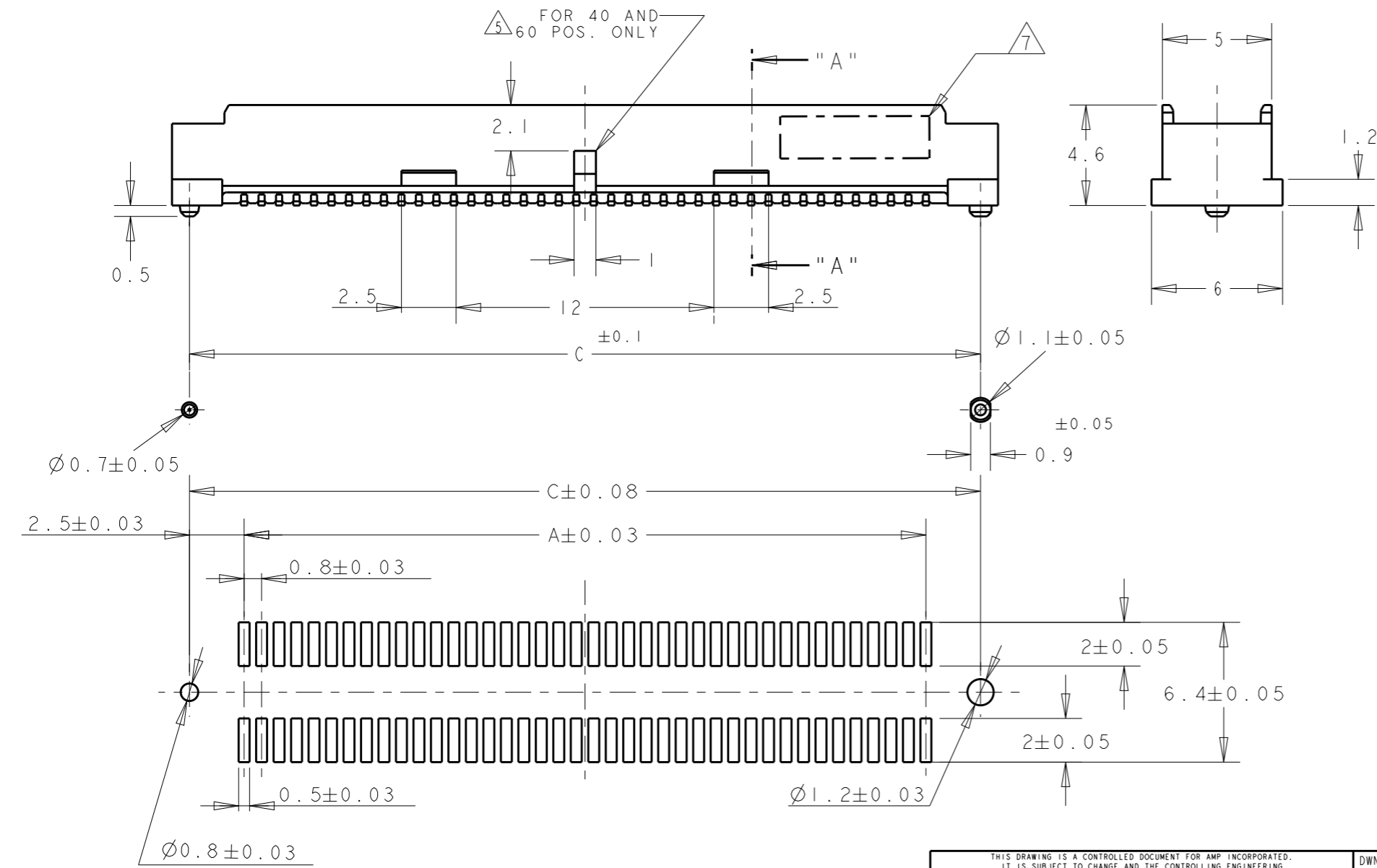

- NOTES;
- 1 MATERIAL: HOUSING: L.C.P. (HIGH TEMP THERMO PLASTIC) UL 94V-0, NATURAL. CONTACT: BRASS.
 - 2 FINISH: UNDERPLATE: 0.0013 MIN NICKEL ALL OVER. ENGAGEMENT AREA: 0.0002 MIN GOLD. SOLDERING AREA: 0.002 MIN MATTE-TIN.
 - 3. POSITION SERIES: SEE TABLE.
 - 4. CONN STACK HEIGHT COMBINE OF PLUG "Y" H VS REC "X" H. STACK HEIGHT = Y + X - 5
 - 5 CUTOUT FEATURE AVAILABLE ONLY ON P/N -1 (40P) AND -2 (60P).
 - 6 FINISH: UNDERPLATE: 0.0013 MIN NICKEL ALL OVER. ENGAGEMENT AREA: 0.00038 MIN GOLD. SOLDERING AREA: 0.002 MIN MATTE-TIN.
 - 7 DATECODE MARKING.
 - 8 CONNECTOR WITH BLACK HOUSING AND POLYIMIDE COVER

P/N SEE SHEET 2 & 3 OF 3.

RECOMMENDED P.C. BOARD LAYOUT

LOW HALOGEN

THIS DRAWING IS A CONTROLLED DOCUMENT FOR AMP INCORPORATED. IT IS SUBJECT TO CHANGE AND THE CONTROLLING ENGINEERING ORGANIZATION SHOULD BE CONTACTED FOR THE LATEST REVISION.		DWN FLORENCE TAN 30AUG04	AMP Tyco Electronics Corporation Singapore
DIMENSIONS: mm		CHK ERIC TNG	
TOLERANCES UNLESS OTHERWISE SPECIFIED: 0 PLC ±- 1 PLC ±0.30 2 PLC ±0.25 3 PLC ±0.20 4 PLC ±- ANGLES ±3°		APVD SEIFONG	NAME PLUG ASSEMBLY 5H TYPE (0.5 BOSS LENGTH) FOR FH 0.8mm PITCH B-T-B CONNECTOR
MATERIAL		PRODUCT SPEC 108-5390	SIZE A3
FINISH SEE TABLE P/N		APPLICATION SPEC 114-5254	CAGE CODE 00779
△		WEIGHT -	DRAWING NO C=5177984
		CUSTOMER DRAWING	SCALE 4:1 SHEET 1 OF 3 REV B

THIS DRAWING IS UNPUBLISHED. RELEASED FOR PUBLICATION .19 .
 © COPYRIGHT 19 BY AMP INCORPORATED. ALL RIGHTS RESERVED.

LOC	DIST	REVISIONS					
DY	-	P	LTR	DESCRIPTION	DATE	DWN	APVD
		-		SEE SHEET 1 OF 3	-	-	-

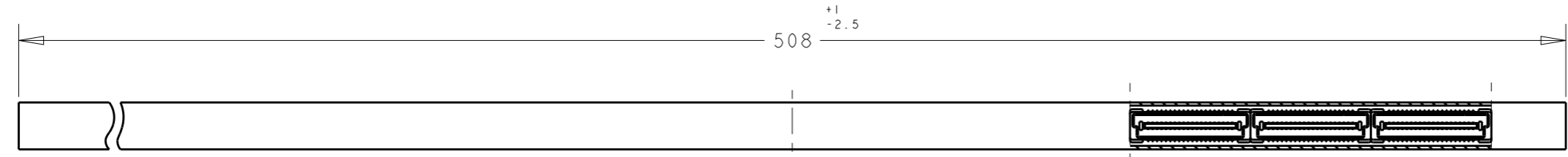

SECT A-A



SECT B-B

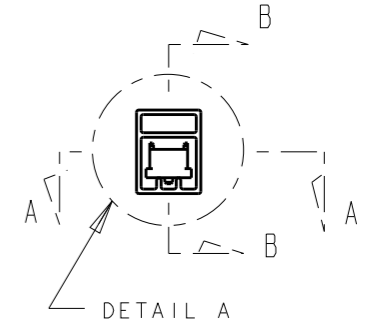

REFERENCE PICTURE OF TUBE PACK

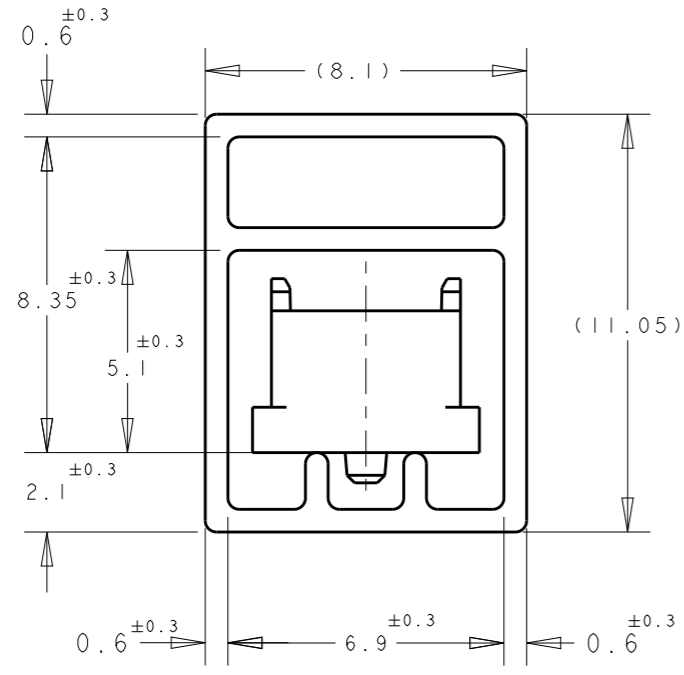

DETAIL A

WITHOUT POLYIMIDE COVER

15Au-Sn △6	5	84.2	85.8	79.2	200	3-	-0
	6	76.2	77.8	71.2	180	2-	-9
	6	68.2	69.8	63.2	160	2-	-8
	7	60.2	61.8	55.2	140	2-	-6
	9	52.2	53.8	47.2	120	2-	-5
	10	44.2	45.8	39.2	100	2-	-4
	12	36.2	37.8	31.2	80	2-	-3
	16	28.2	29.8	23.2	60	2-	-2
	22	20.2	21.8	15.2	40	2-	-1
	08Au-Sn △2	5	84.2	85.8	79.2	200	1-
6		76.2	77.8	71.2	180		-9
6		68.2	69.8	63.2	160		-8
7		60.2	61.8	55.2	140		-6
9		52.2	53.8	47.2	120		-5
10		44.2	45.8	39.2	100		-4
12		36.2	37.8	31.2	80		-3
16		28.2	29.8	23.2	60		-2
22	20.2	21.8	15.2	40		5177984-1	
FINISH	QTY/TUBE	C	B	A	POS.	CONN P/N	

LOW HALOGEN

THIS DRAWING IS A CONTROLLED DOCUMENT FOR AMP INCORPORATED. IT IS SUBJECT TO CHANGE AND THE CONTROLLING ENGINEERING ORGANIZATION SHOULD BE CONTACTED FOR THE LATEST REVISION.		DWN FLORENCE TAN 30AUG04	Tyco Electronics Corporation Singapore	
DIMENSIONS: mm	TOLERANCES UNLESS OTHERWISE SPECIFIED: 0 PLC ±- 1 PLC ±0.30 2 PLC ±0.25 3 PLC ±0.20 4 PLC ±- ANGLES ±3°	CHK ERIC TNG	NAME PLUG ASSEMBLY 5H TYPE (0.5 BOSS LENGTH) FOR FH 0.8mm PITCH B-T-B CONNECTOR	
MATERIAL △	FINISH SEE TABLE P/N	APVD SEIFONG	PRODUCT SPEC 108-5390	DRAWING NO C=5177984
		APPLICATION SPEC 114-5254	WEIGHT -	SCALE - SHEET 2 OF 3 REV B
CUSTOMER DRAWING			SIZE A3	CAGE CODE 00779

THIS DRAWING IS UNPUBLISHED. RELEASED FOR PUBLICATION .19 .
 © COPYRIGHT 19 BY AMP INCORPORATED. ALL RIGHTS RESERVED.

LOC	DIST	REVISIONS			
P	LTR	DESCRIPTION	DATE	DWN	APVD
DY	-	SEE SHEET 1 OF 3	-	-	-

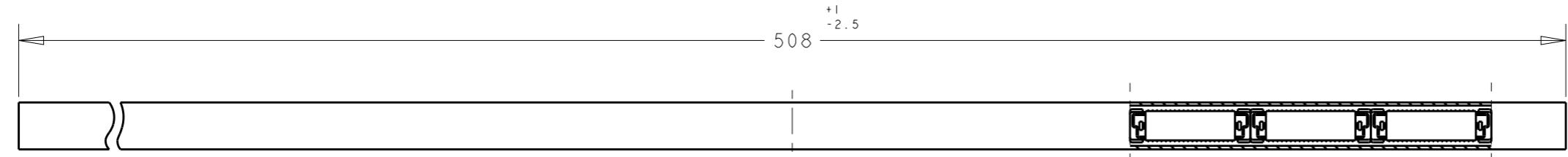

SECT A-A



SECT B-B

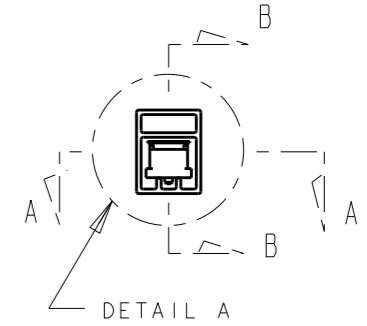

REFERENCE PICTURE OF TUBE PACK

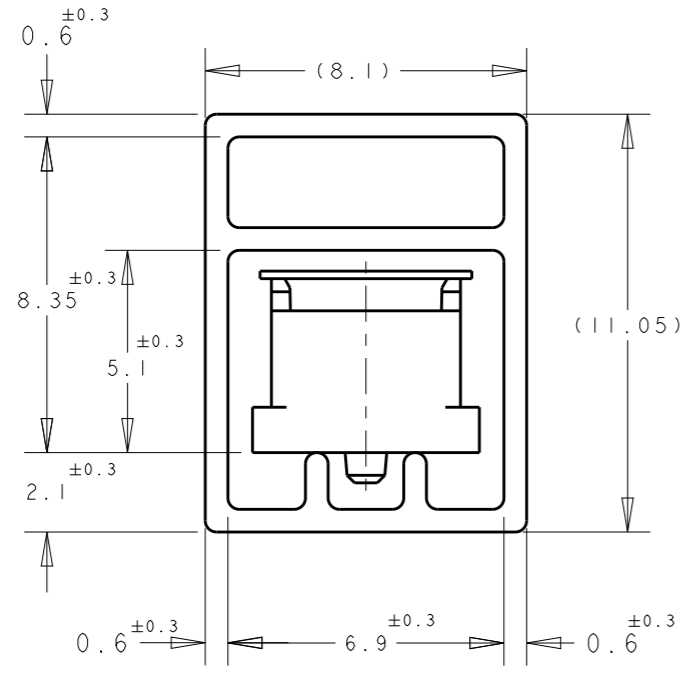

DETAIL A

WITH POLYIMIDE COVER

△ 8	08Au-Sn	2	7	60.2	61.8	55.2	140	9-5177984-6
FINISH	QTY/TUBE	C	B	A	POS.	CONN P/N		

LOW HALOGEN

THIS DRAWING IS A CONTROLLED DOCUMENT FOR AMP INCORPORATED. IT IS SUBJECT TO CHANGE AND THE CONTROLLING ENGINEERING ORGANIZATION SHOULD BE CONTACTED FOR THE LATEST REVISION.		DWN FLORENCE TAN 30AUG04	Tyco Electronics Corporation Singapore	
DIMENSIONS: mm	TOLERANCES UNLESS OTHERWISE SPECIFIED:	CHK ERIC TNG	NAME PLUG ASSEMBLY 5H TYPE (0.5 BOSS LENGTH) FOR FH 0.8mm PITCH B-T-B CONNECTOR	
0 PLC ±- 1 PLC ±0.30 2 PLC ±0.25 3 PLC ±0.20 4 PLC ±- ANGLES ±3°		APVD SEIFONG	DRAWING NO C-5177984	
MATERIAL	FINISH	PRODUCT SPEC 108-5390	SIZE A3	CAGE CODE 00779
	SEE TABLE P/N	APPLICATION SPEC 114-5254	SCALE - SHEET 3 OF 3 REV B	
		WEIGHT -	CUSTOMER DRAWING	

Компания «Life Electronics» занимается поставками электронных компонентов импортного и отечественного производства от производителей и со складов крупных дистрибьюторов Европы, Америки и Азии.

С конца 2013 года компания активно расширяет линейку поставок компонентов по направлению коаксиальный кабель, кварцевые генераторы и конденсаторы (керамические, пленочные, электролитические), за счёт заключения дистрибьюторских договоров

Мы предлагаем:

- Конкурентоспособные цены и скидки постоянным клиентам.
- Специальные условия для постоянных клиентов.
- Подбор аналогов.
- Поставку компонентов в любых объемах, удовлетворяющих вашим потребностям.
- Приемлемые сроки поставки, возможна ускоренная поставка.
- Доставку товара в любую точку России и стран СНГ.
- Комплексную поставку.
- Работу по проектам и поставку образцов.
- Формирование склада под заказчика.
- Сертификаты соответствия на поставляемую продукцию (по желанию клиента).
- Тестирование поставляемой продукции.
- Поставку компонентов, требующих военную и космическую приемку.
- Входной контроль качества.
- Наличие сертификата ISO.

В составе нашей компании организован Конструкторский отдел, призванный помогать разработчикам, и инженерам.

Конструкторский отдел помогает осуществить:

- Регистрацию проекта у производителя компонентов.
- Техническую поддержку проекта.
- Защиту от снятия компонента с производства.
- Оценку стоимости проекта по компонентам.
- Изготовление тестовой платы монтаж и пусконаладочные работы.



Тел: +7 (812) 336 43 04 (многоканальный)

Email: org@lifeelectronics.ru