

ON Semiconductor®

LED FRONTLIGHTING SOLUTIONS APG/AAB

NCV78763 LDM A – REFERENCE DESIGN KIT

QUICK START GUIDE & SYSTEM OVERVIEW

Document version 1.6 – 29th of Aug 2016

Christiam Gasparini
System Application Engineer
Automotive APG/AAB BU - Belgium



Confidential

ON Semiconductor®



NCV78763 LDM A
v1.1
Quick Start Guide
KIT OVERVIEW



NCV78763 REF DES LDM A – KIT OVERVIEW

- The NCV78763 REF Design LDM A KIT v1.1 is meant for Automotive LED Front Lighting Advanced Applications for Day Time Running Light (DRL), Position Light (PL) and Turn Indicator (TURN), aimed for car bulb equivalent system replacement and migration to Power LEDs. Content:

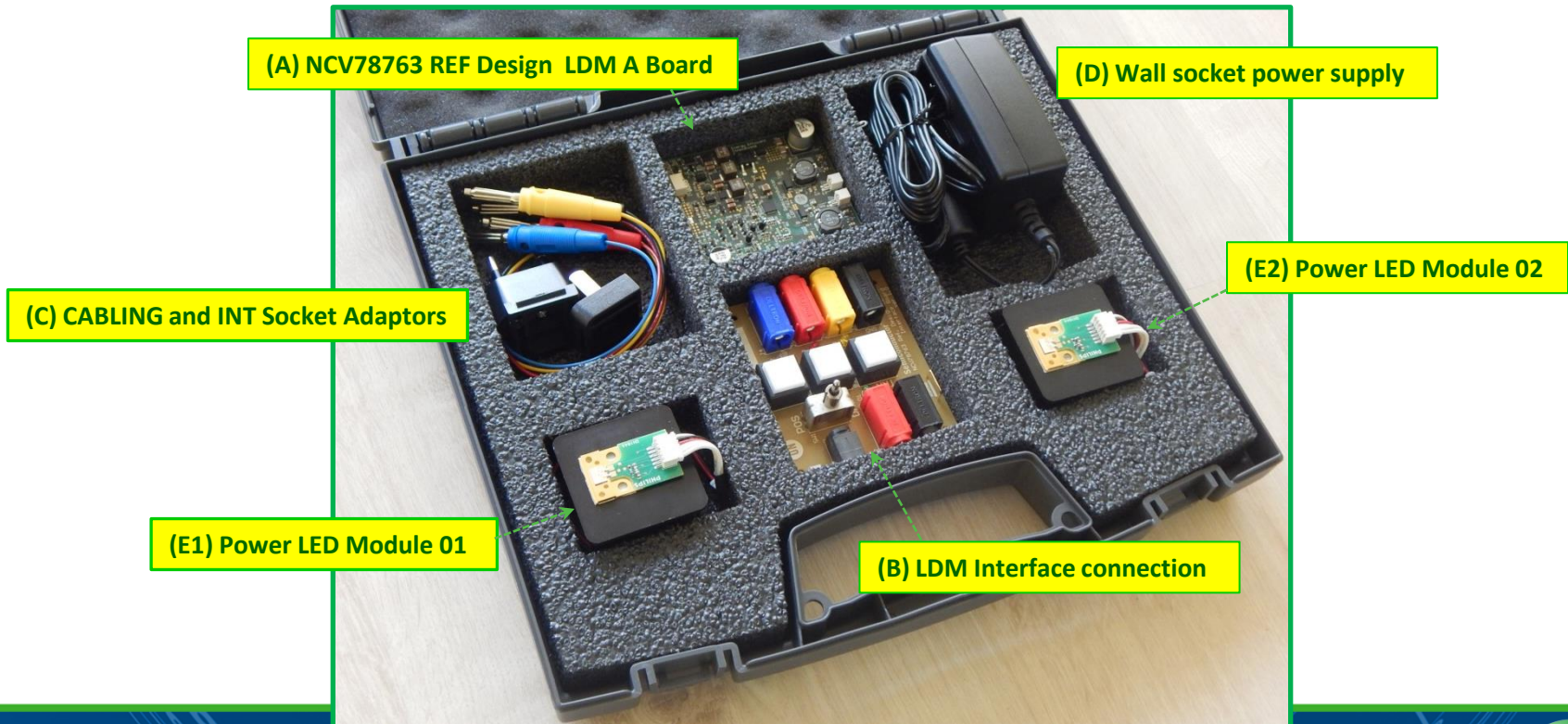

NCV78763 REF DES LDM A – Main Features sheet

- The NCV78763 REF Design LDM A system solution is based on the NCV78763 Power LED Driver for Front Lighting (APG/AAB BU), with a **full ONSEMI BOM portfolio for external power devices.**
- The module features **failure diagnostics** as open load detection, short circuit protection and thermal protection lock out. A low pin count 8-bit microcontroller is embedded on board for such monitoring and control.
- The LED strings (DRL/PL) are driven according to **advanced dimming control techniques** including **logarithmic** ramps analog and digital modulation for enhanced human eye sensitivity smoothness perception. The implementation fully exploits the SPI bus and LED Driver settings.
- Other **key characteristics** of the NCV78763 LDM A include: **compact electronics**, compatibility target with automotive bulb architectures and **ONSEMI Platform design approach** for:
 - a) Compatibility with a wide range of LED strings configuration without BOM change
 - b) Easily customizable to the specific system requirements.
 - c) Wide supply VBAT Operating range from 5V to 20V or higher.



NCV78763 REF DES LDM A & Bulb Systems Compatibility

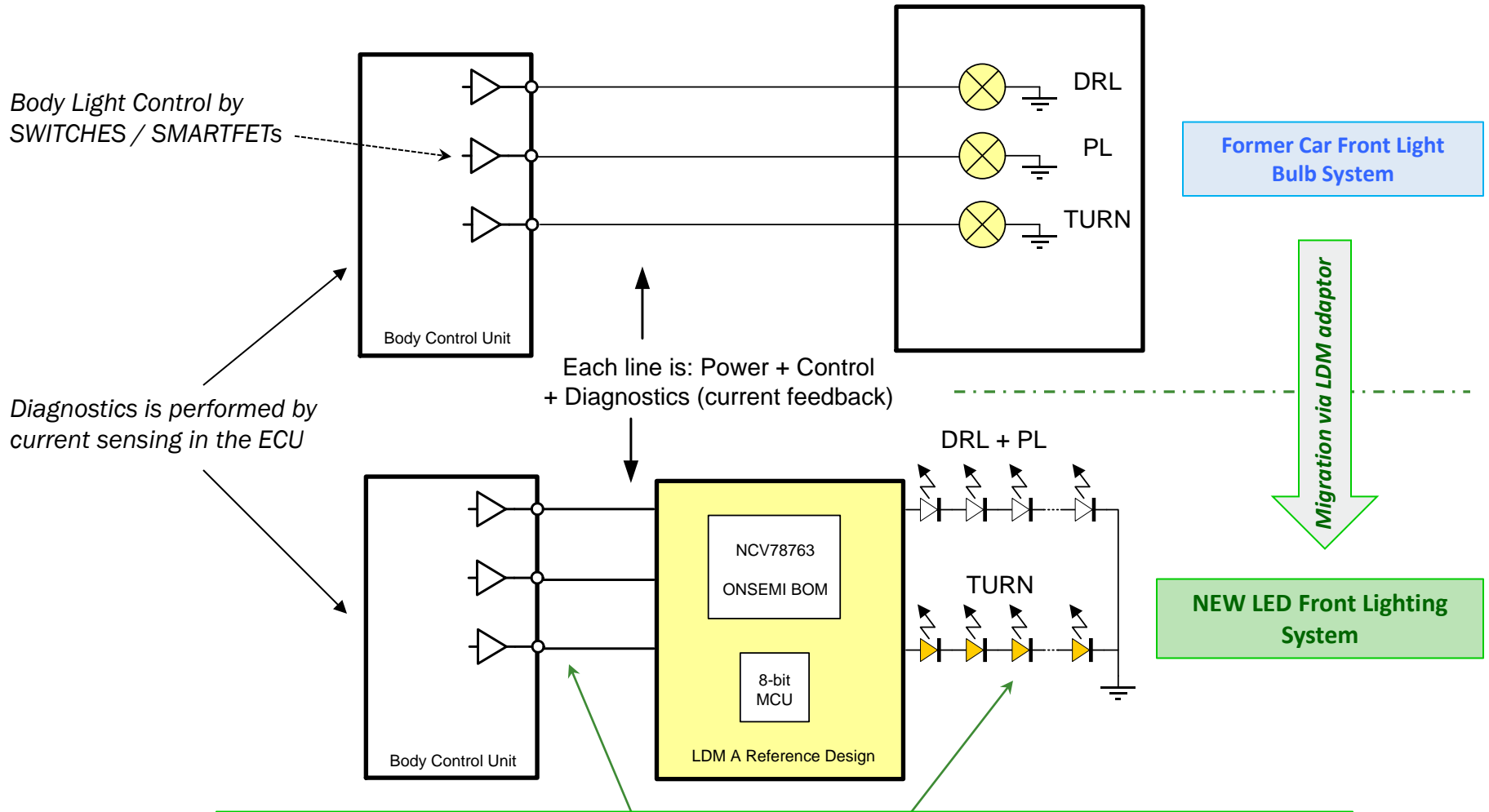

NCV78763 LDM A as Bulb to LED migration adaptor
The module inputs to outputs functionality is configurable via the embedded MCU





NCV78763 LDM A
v1.1
Quick Start Guide
HW SETUP



NCV78763 LDM A REF DES KIT: Main board LDM

- The NCV78763 LDM A Board, core of the system, is shown hereby. Its BOM is sized to allow the outputs to drive LED strings for a total power of above 20W and up to 60V voltage.
- LED Chan 01 is dedicated to DRL and PL, controlled via logarithmic dimming slopes ramp, while channel 02 performs the turn indicator (blinker) function.

Four ways input connector
Input 01: DRL
Input 02: PL
Input 03: TURN
Input 04: GND

Twice-Two wires output connectors:
Output 01: HOT/ANODE (RED)
Output 01: GND/CATHODE (BLACK)
Output 02: HOT/ANODE (RED)
Output 02: GND/CATHODE (BLACK)

NCV78763 LDM A – REF Design
Board (KIT ITEM A)

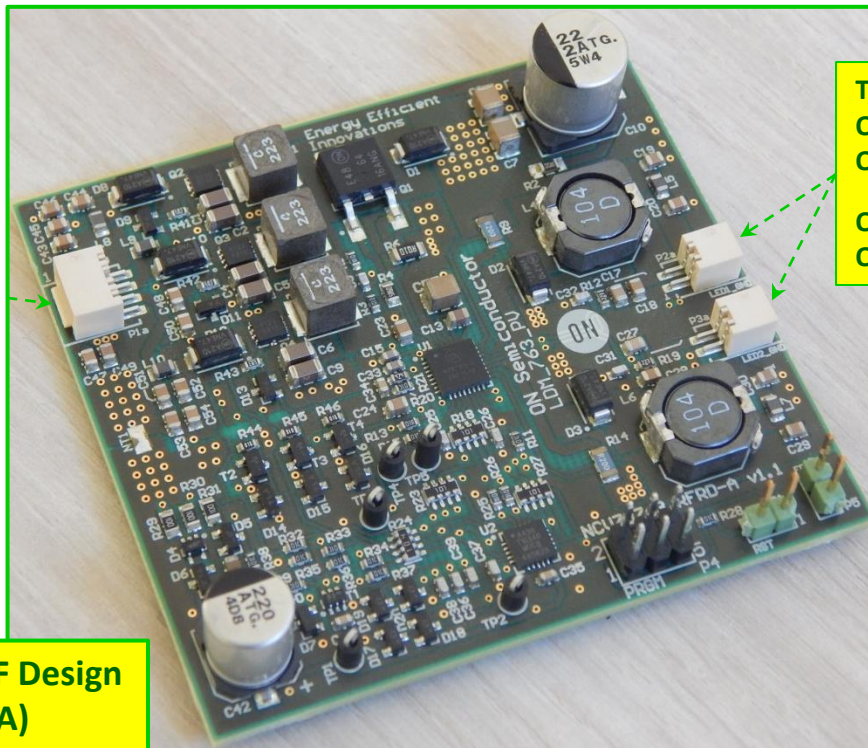

NCV78763 LDM A REF DES KIT: the LDM Interface

- The LDM REF Design A Interface (ITEM B) grants additional flexibility for use of an wall socket power supply and allows straightforward commands by the user via buttons and switch.

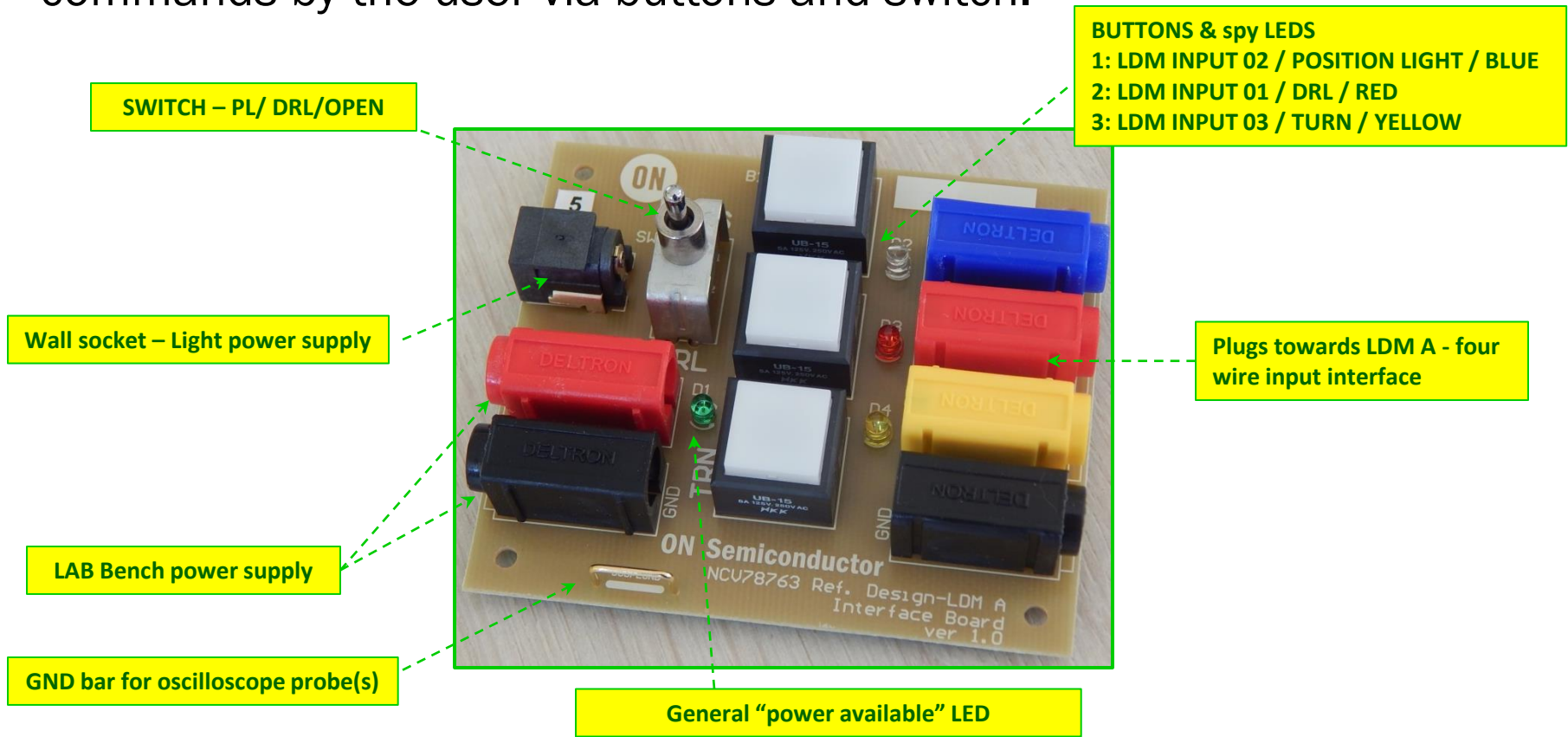

NCV78763 LDM A REF DES KIT: Cabling & connections

- The NCV78763 LDM A KIT modules come equipped with cabling (KIT ITEM C) for easy interface towards a **standard bench power supply** or the official LDM REF Design A interface (KIT ITEM B):

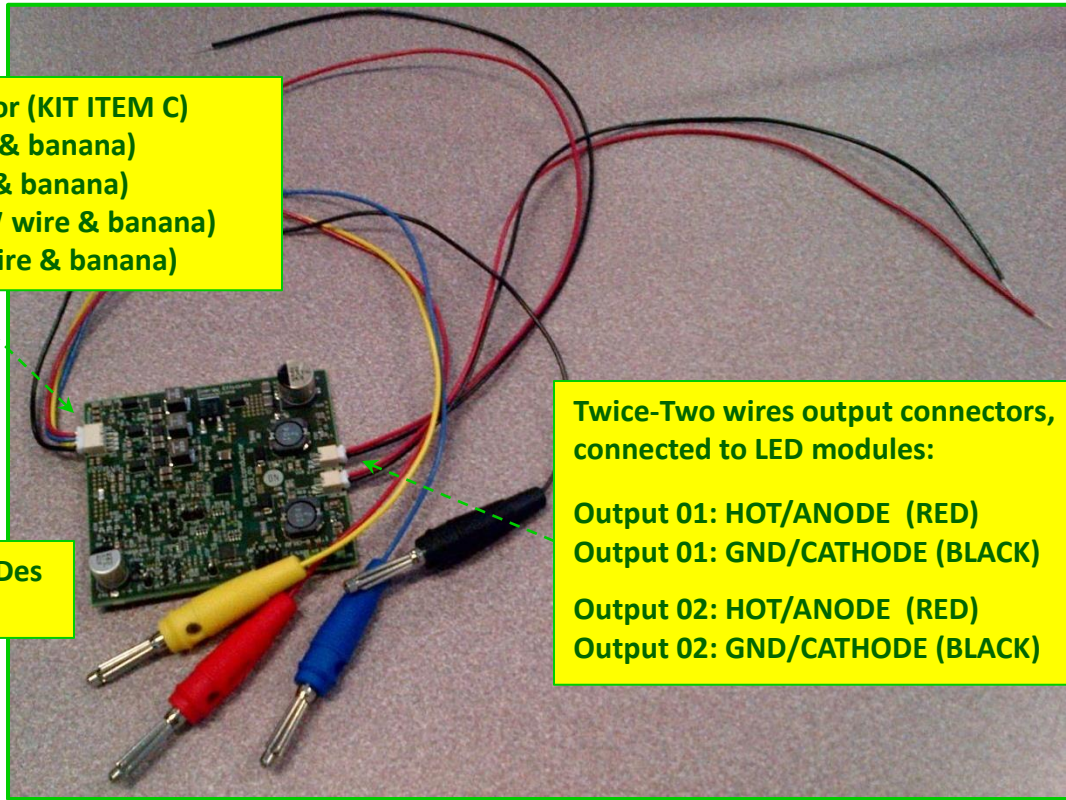

Four wires input connector (KIT ITEM C)
Input 01 / DRL (RED wire & banana)
Input 02 / PL (BLUE wire & banana)
Input 03 / TURN (YELLOW wire & banana)
Input 04 / GND (BLACK wire & banana)

NCV78763 LDM A – REF Des Board (KIT ITEM A)

Twice-Two wires output connectors, connected to LED modules:
Output 01: HOT/ANODE (RED)
Output 01: GND/CATHODE (BLACK)
Output 02: HOT/ANODE (RED)
Output 02: GND/CATHODE (BLACK)



NCV78763 LDM A REF DES KIT: Power Supply and plug adapters

- The provided power supply can be directly plugged in the LDM interface, in absence of a bench power supply, or for highly portable ready-to-go demos.

12V/3A light power supply – KIT ITEM D

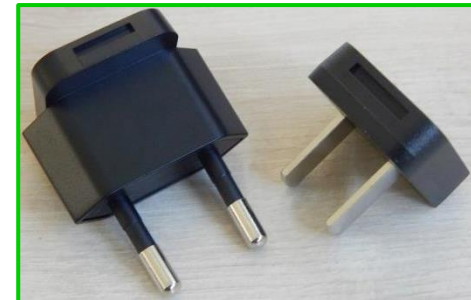

Flexible overall use wall socket adaptation (E.G. EU/US plugs)

NCV78763 LDM A REF DES KIT: Power LED Modules

- For reference and immediate use, the KIT contains commercial Automotive LED Modules (Philips – GH1644). Two samples are available per KIT. The LED plates are equipped a customized compact heatsink and cabling to be plugged to the NCV78763 LDM A.

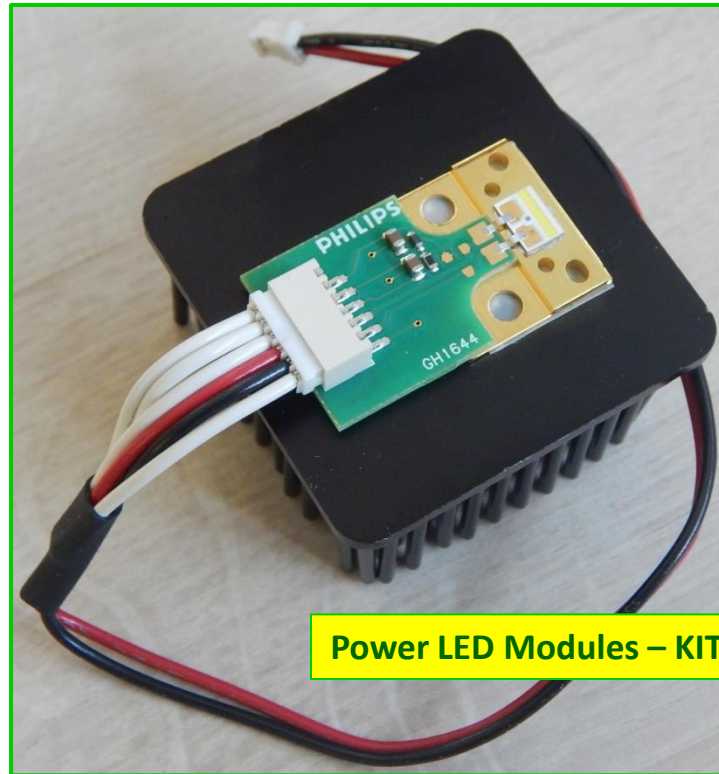

Power LED Modules – KIT ITEMS E1/E2

NCV78763 LDM A REF DES KIT: the entire setup system

- The connections of all previous elements brings to the following:

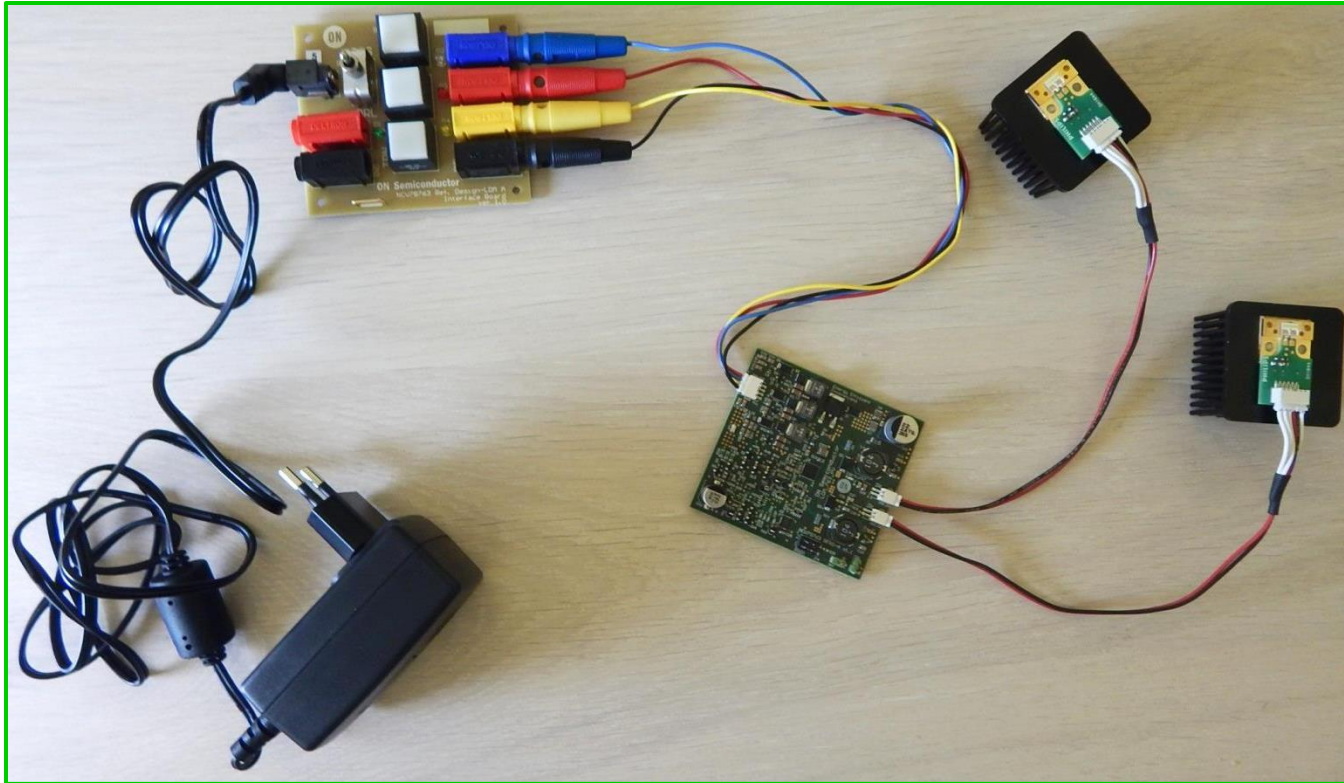

NCV78763 LDM A REF DES KIT: The APRGM (optional)

- The standard **factory firmware** is set to drive the default KIT LED modules, for 10W power in steady state (around 580mA DC current). Using a different LED string below 22V, the same current will be applied.
- The system embeds **enhanced feature**, allowing to adapt parameters to **completely different string and/or headlight** per means of the programmer shown (APRGM). The current levels for channels 01 and 02 are adjusted via the two respective trimmers. The microcontroller takes care of safety related items such as power level and voltage adjustments, current limitation and EEPROM memory save.

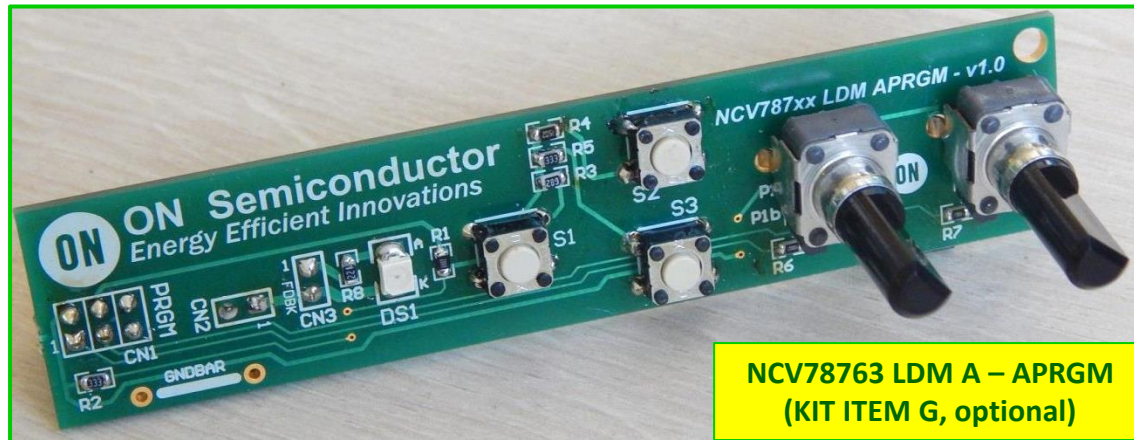

NCV78763 LDM A REF DES KIT: APRGM – Setup

- In order to allow the current and LED strings programming procedure, the APRGM board, when the system is in **power off**, must first be plugged into the three LDM A main board connectors “P4” “S1” and “P5” (respectively CN1, CN2 and CN3 in APRGM).

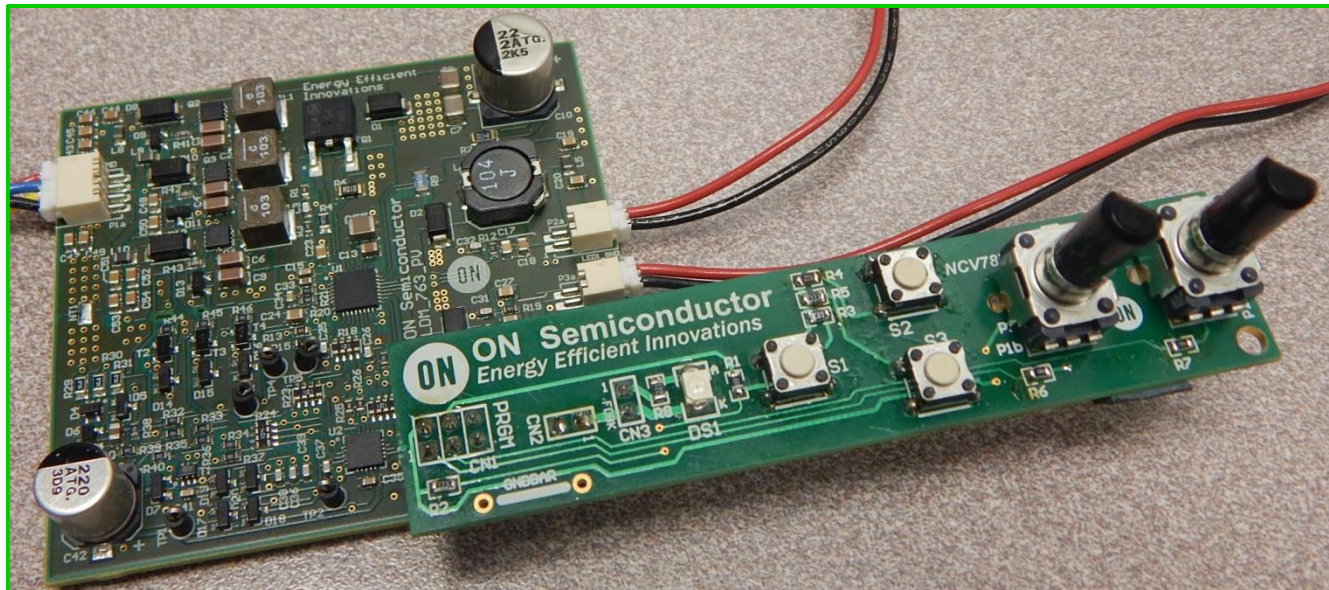

NCV78763 LDM A – APRGM: LED current programming procedure setup

NCV78763 LDM A REF DES KIT: APRGM – Procedure #1

- After setup, the LED current programming procedure is actually entered when, powering up the system, the button S3 is kept pressed. Details on the procedure are reported below.
1. When entering programming procedure, the **LED DS1 will start blinking. Release button S3.** Before driving current into the LED strings, the microcontroller will wait that the user brings the trimmers P1 and P2 (current setting knobs) to the left most position (counter-clock-wise) to preselect the minimum current level: whenever this position is attained, the LDM will drive currents in both LED strings. At any time, the sequence can be exited without save by pressing “S2”;
 2. Adjust the current in the LEDs. The right setting can be found by human visual perception such as lighting of a dark room (never look directly in the LED source to potential avoid health hazard or dazzling!), light intensity measurement, a current measurement probe, or series multimeter in current sensing mode;
 3. Once the desired current is found, new settings are save by pressing “S1”;
 4. As an alternative, original factory settings can always be restored with the “S3” button.

Please note that **any LED string between 2V and 60V** can be used. The firmware will limit the current so that 10W maximum per channel can be delivered.



NCV78763 LDM A REF DES KIT: APRGM – Procedure #2

- Please refer to the following picture for a graphical explanation of the LED current setting programming procedure.

LED DS1:

- User feedback (blink code)

Button S2:

- Exit immediately without saving when programming procedure is running

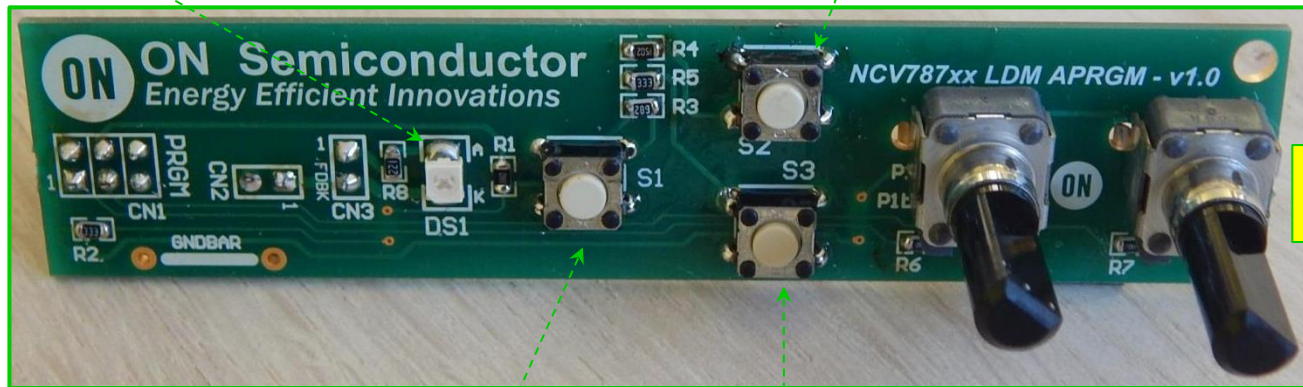

Trimmer P1 & P2:
LED Chan 01 & 02 settings

Button S1:

- Exit programming feature and Save new user settings

Button S3:

- Enter procedure while powering up
- Save factory settings when programming procedure is running





NCV78763 LDM A
v1.1
System Overview
Design



NCV78763 LDM A REF DES: PCB Board 3D Overview

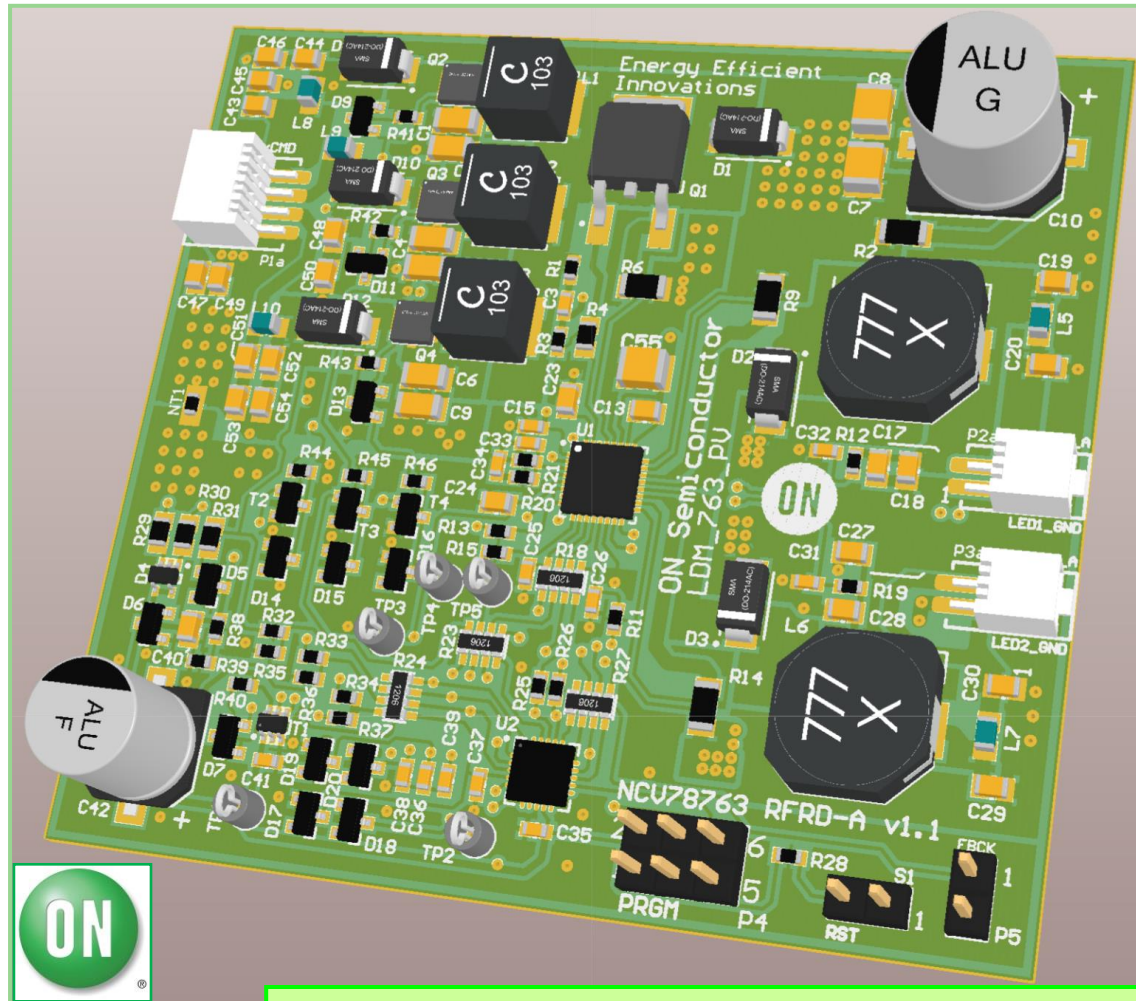

NCV78763 LDM A 3D image - PCB Size: 68mm xx 63mm



NCV78763 LDM A REF DES: Schematics (top-level view)

The LDM A REF DES v1.1 top level block schematics view is shown below:

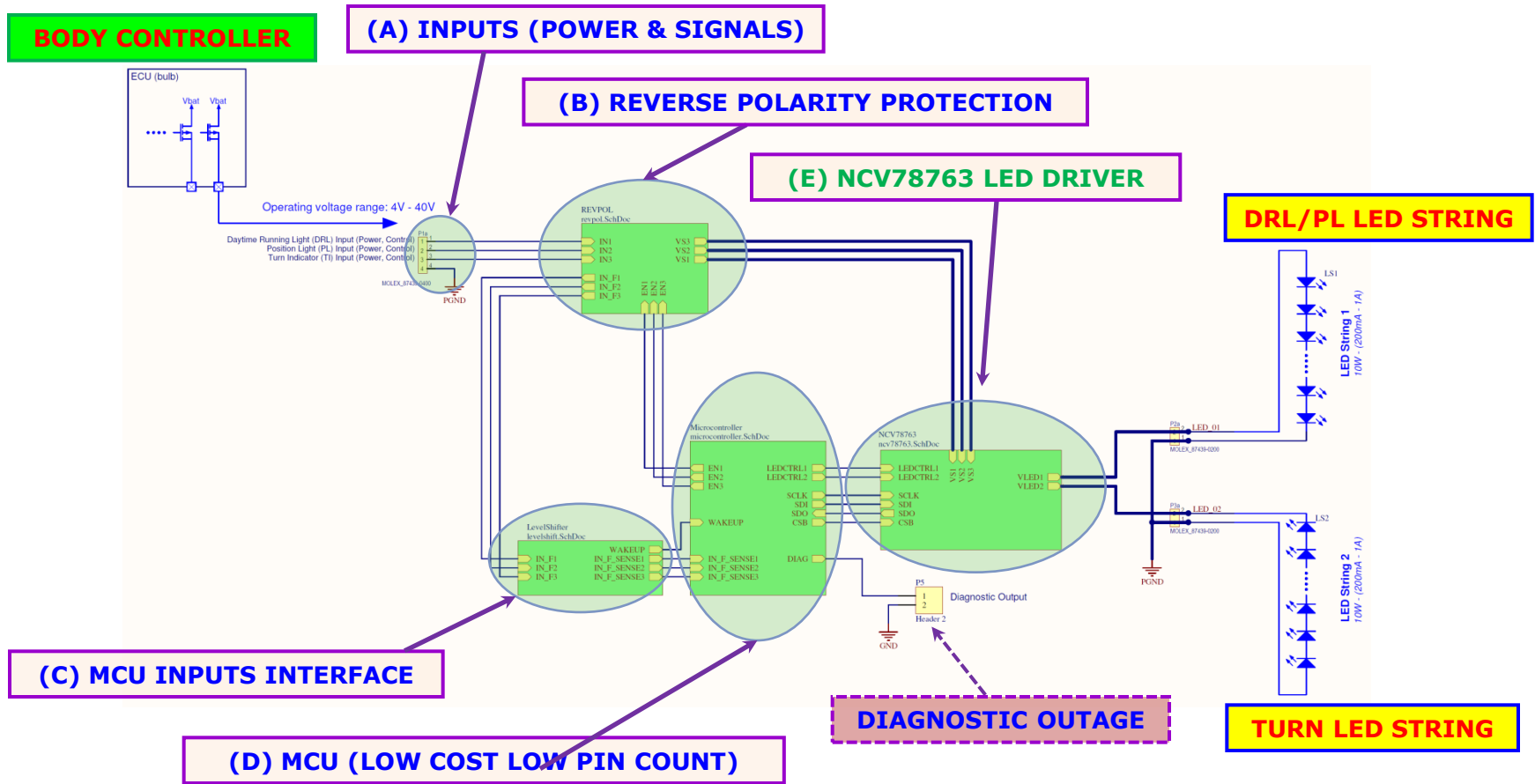

NCV78763 LDM A REF DES: sub-circuit #B: reverse battery

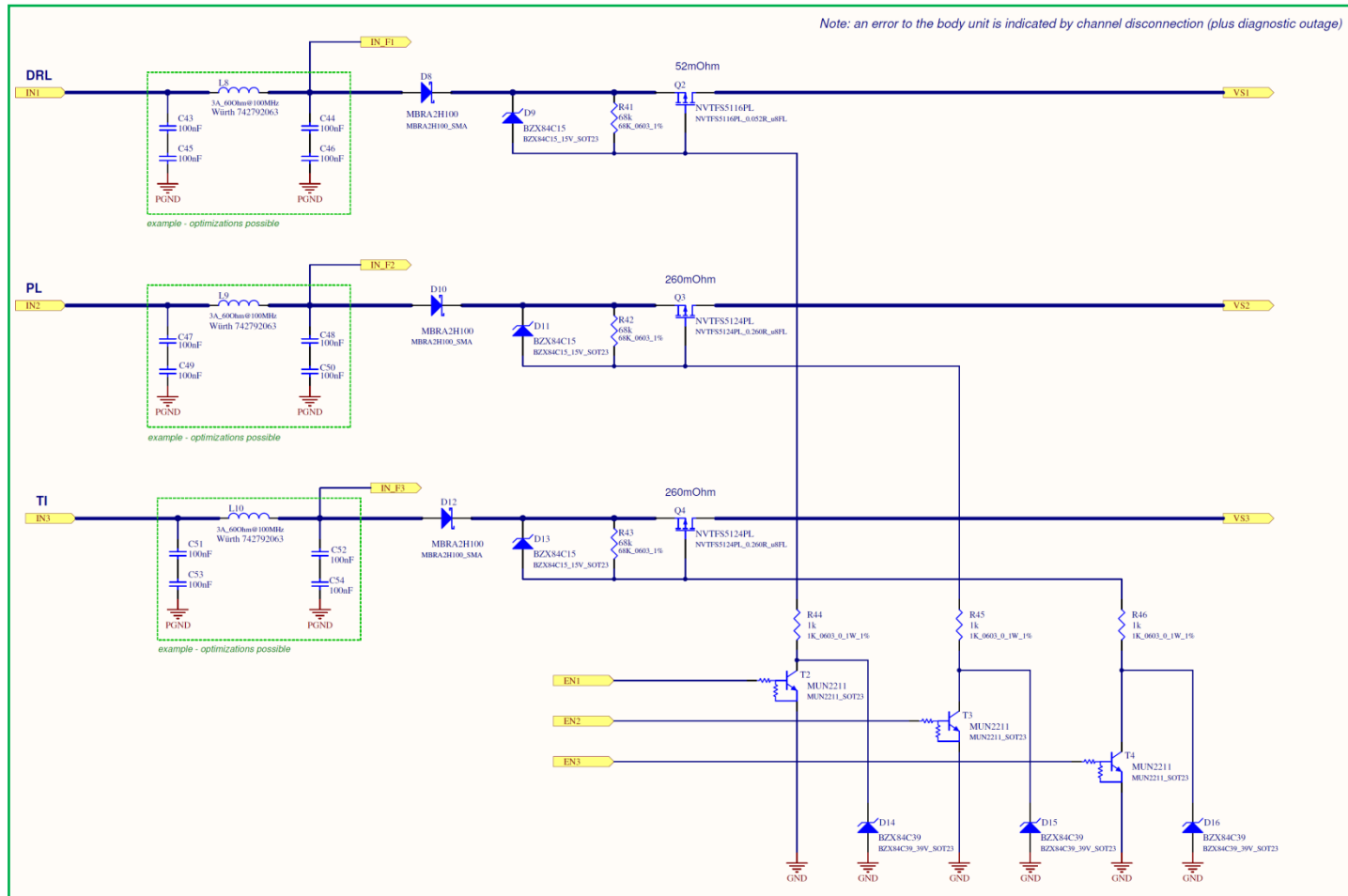

NCV78763 LDM A REF DES: sub-circuit #C: MCU interface

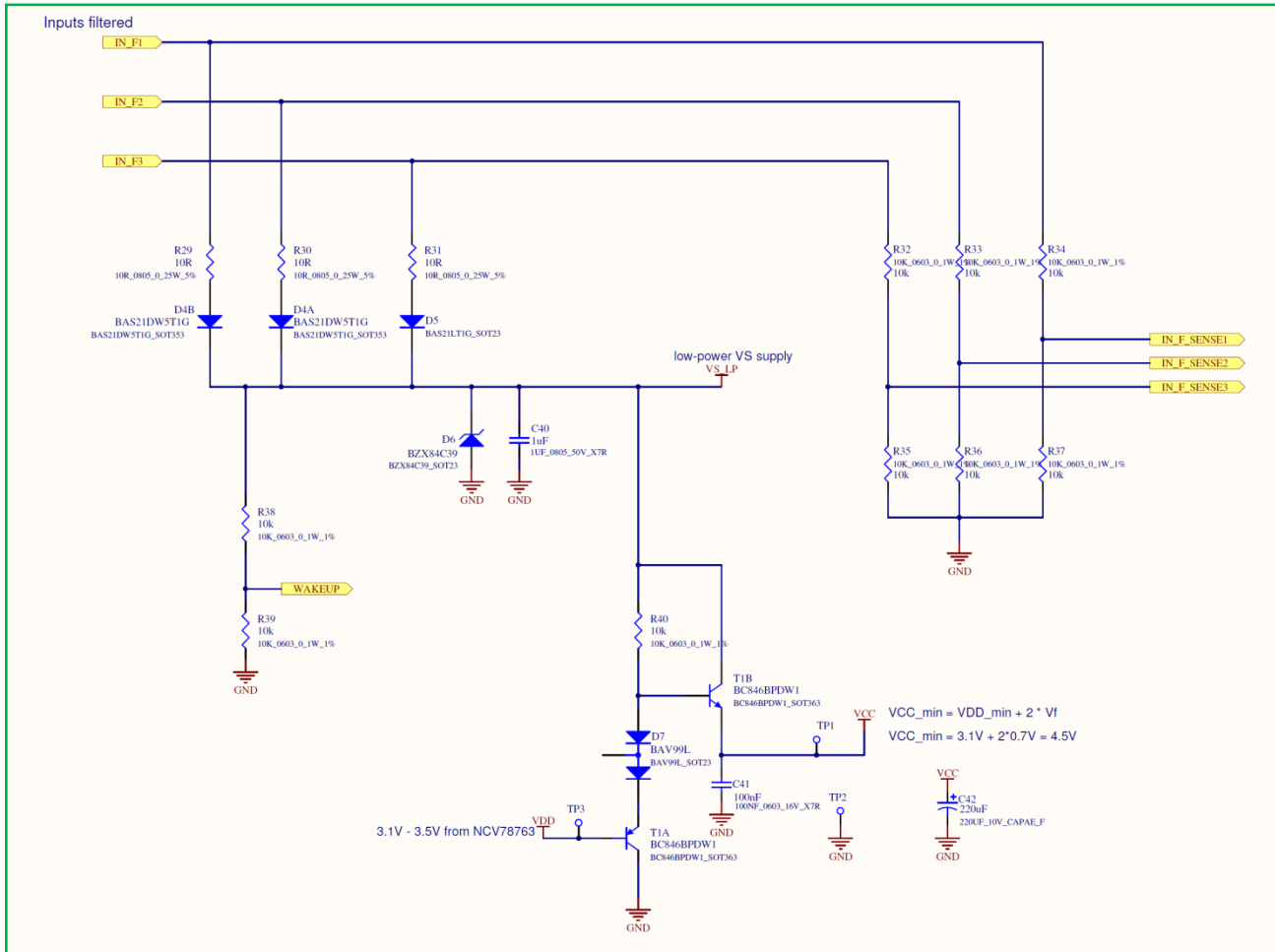

NCV78763 LDM A REF DES: sub-circuit #D: MCU

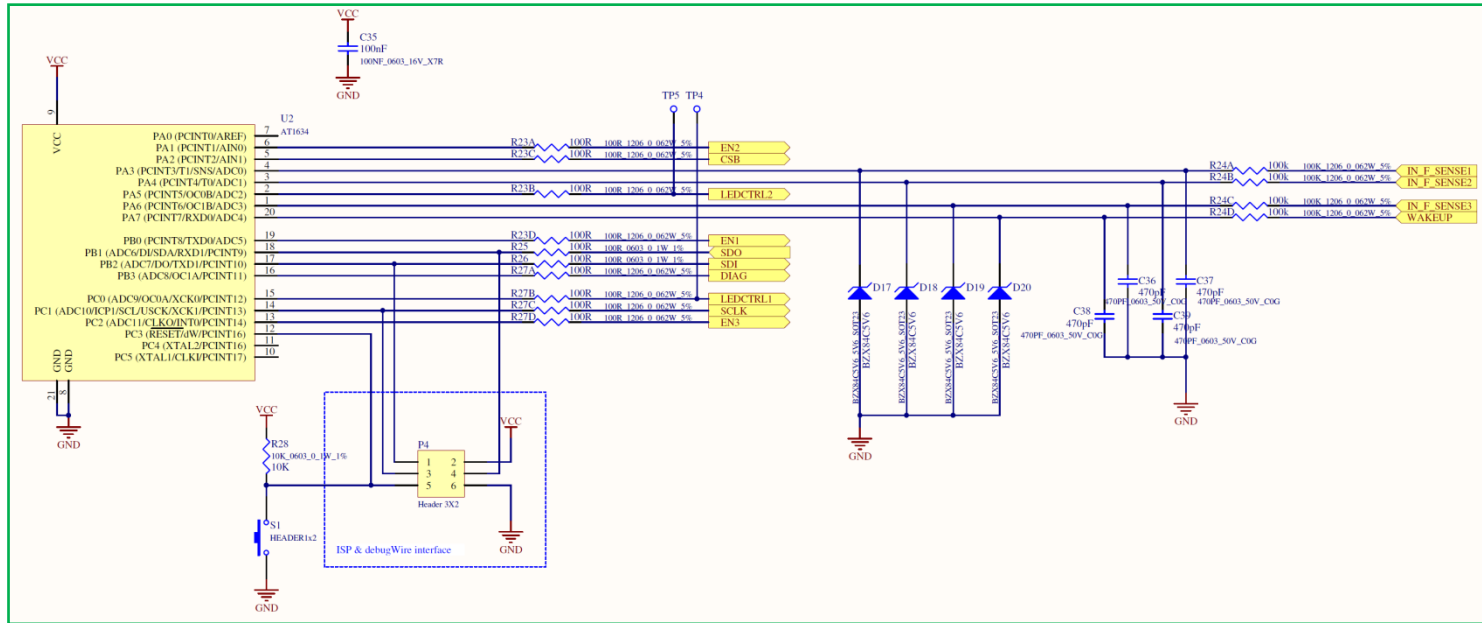

NCV78763 LDM A REF DES: sub-circuit #E: NCV78763

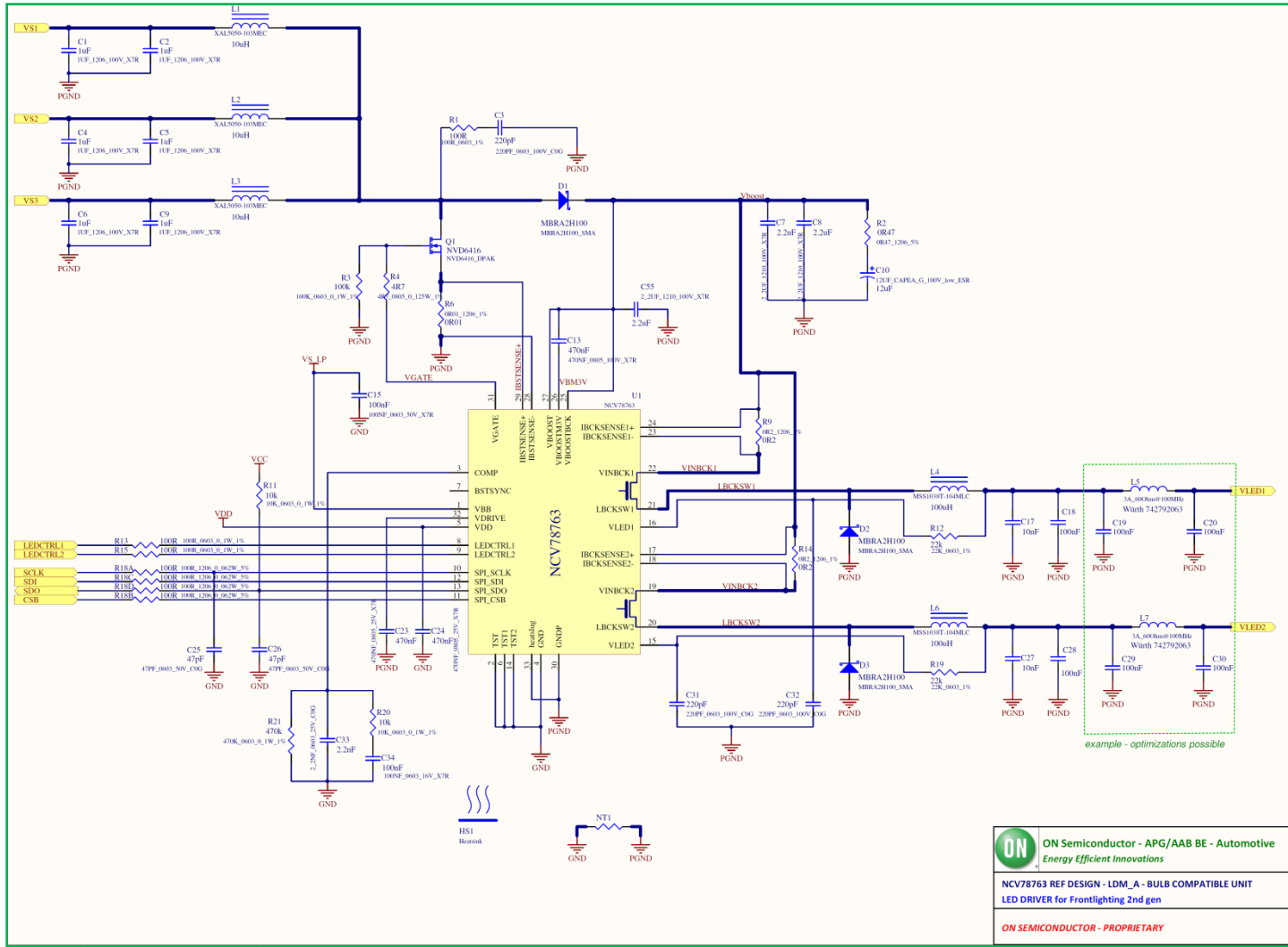

ON ON Semiconductor - APG/AAB BE - Automotive
Energy Efficient Innovations

NCV78763 REF DESIGN - LDM_A - BULB COMPATIBLE UNIT
LED DRIVER for Frontlighting 2nd gen

ON SEMICONDUCTOR - PROPRIETARY



NCV78763 LDM A REF DES: PCB (top side)

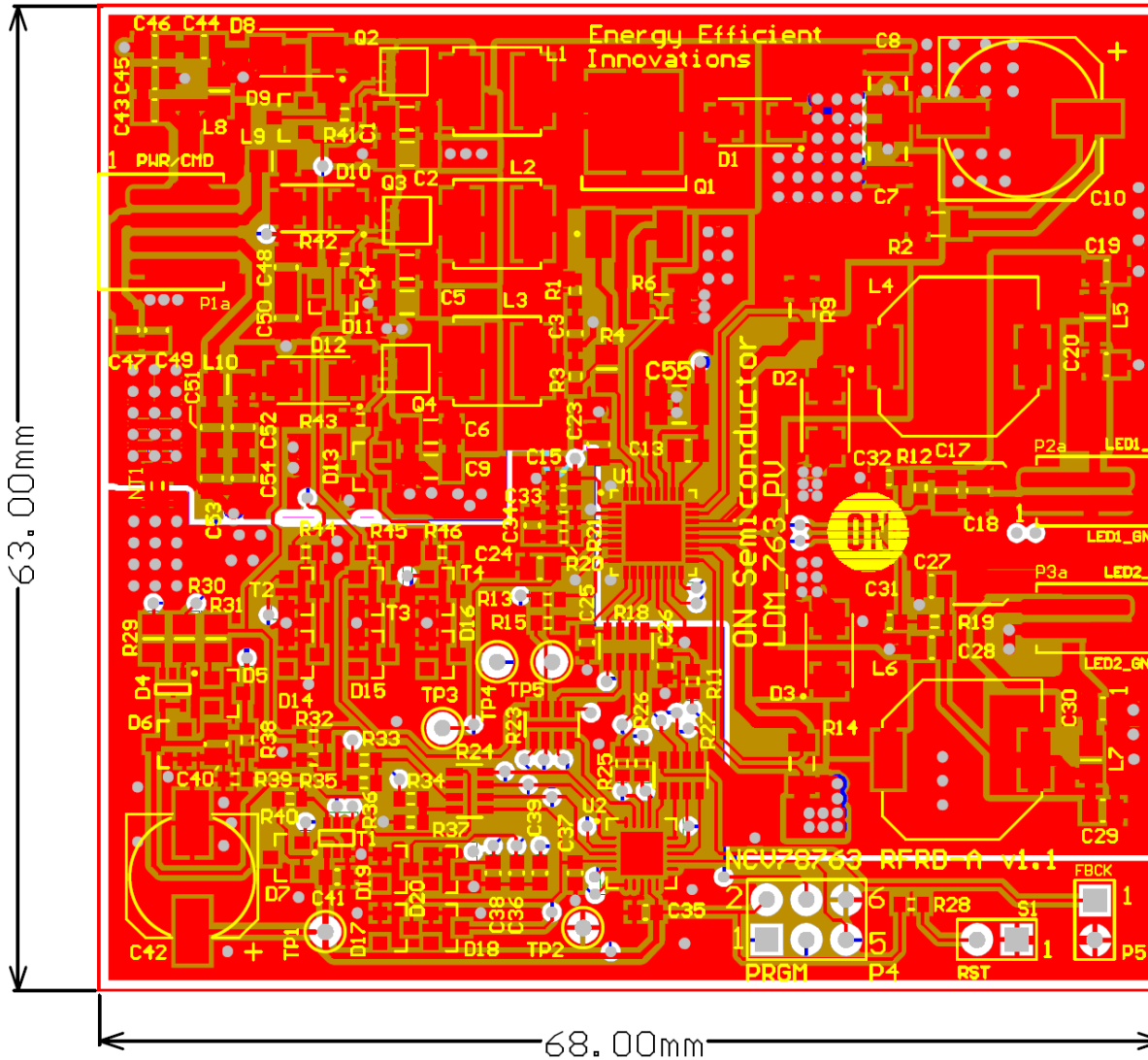



NCV78763 LDM A
v1.1
System Overview
Measurement
Report



Measurement report: *DRL ramp turn-on*

- At power on (line #1 = DRL input), the DRL led string is ramped to the nominal current value by combining analog and digital dimming (logarithmic mode is shown).

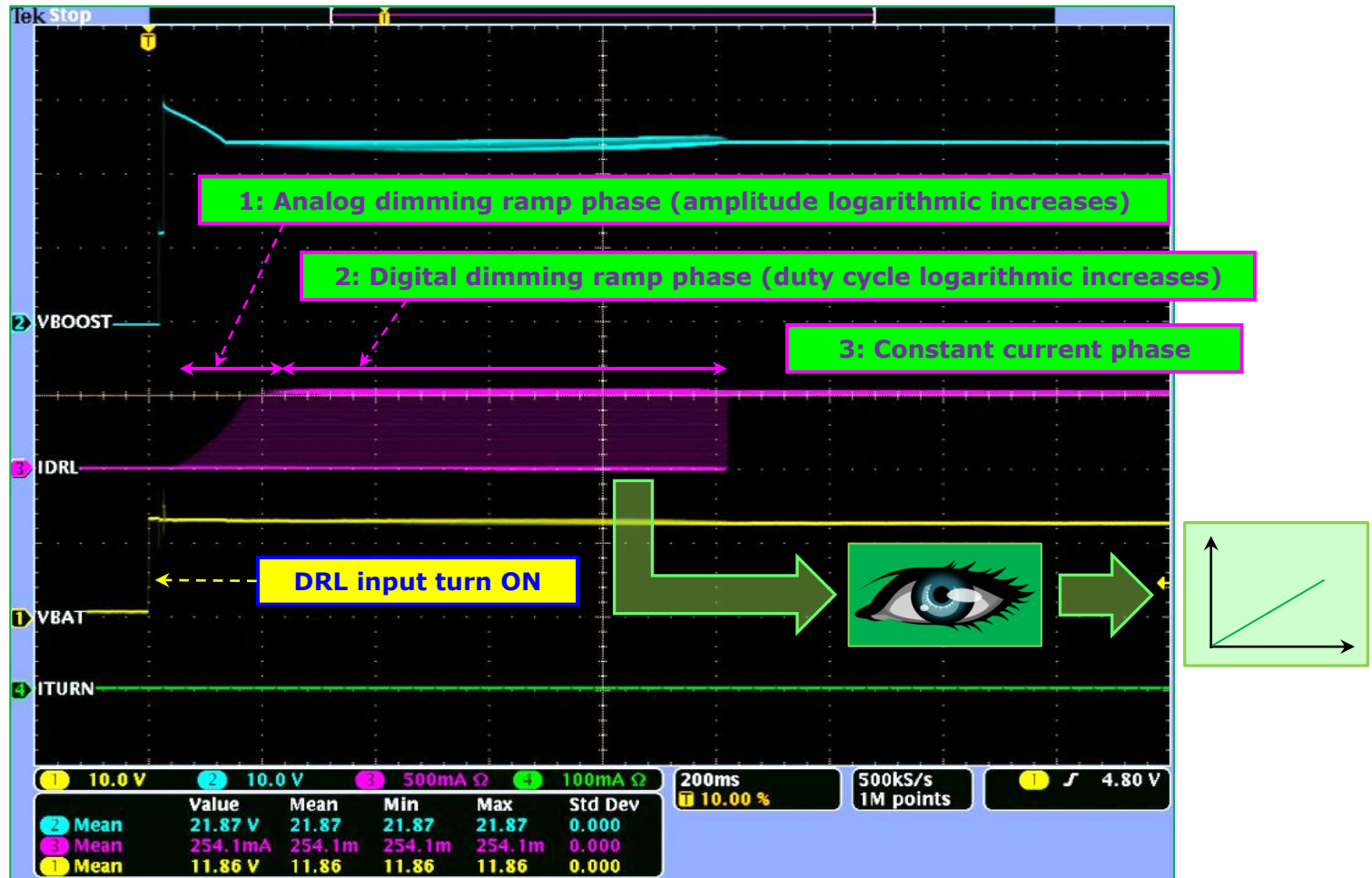

System steady state stability (low VBAT = 7V)



System steady state stability (nom VBAT = 13V)



System steady state stability (nom VBAT = 19V)



PSRR stability (VBAT = 10V >>> 20V)



PSRR stability (VBAT = 20V >>> 10V)



Diagnostic & specific input turn-off

- In this diagnostic detection example, the output VLED is shorted to GND.
- The module turns off the input to flag to the body controller the failure.

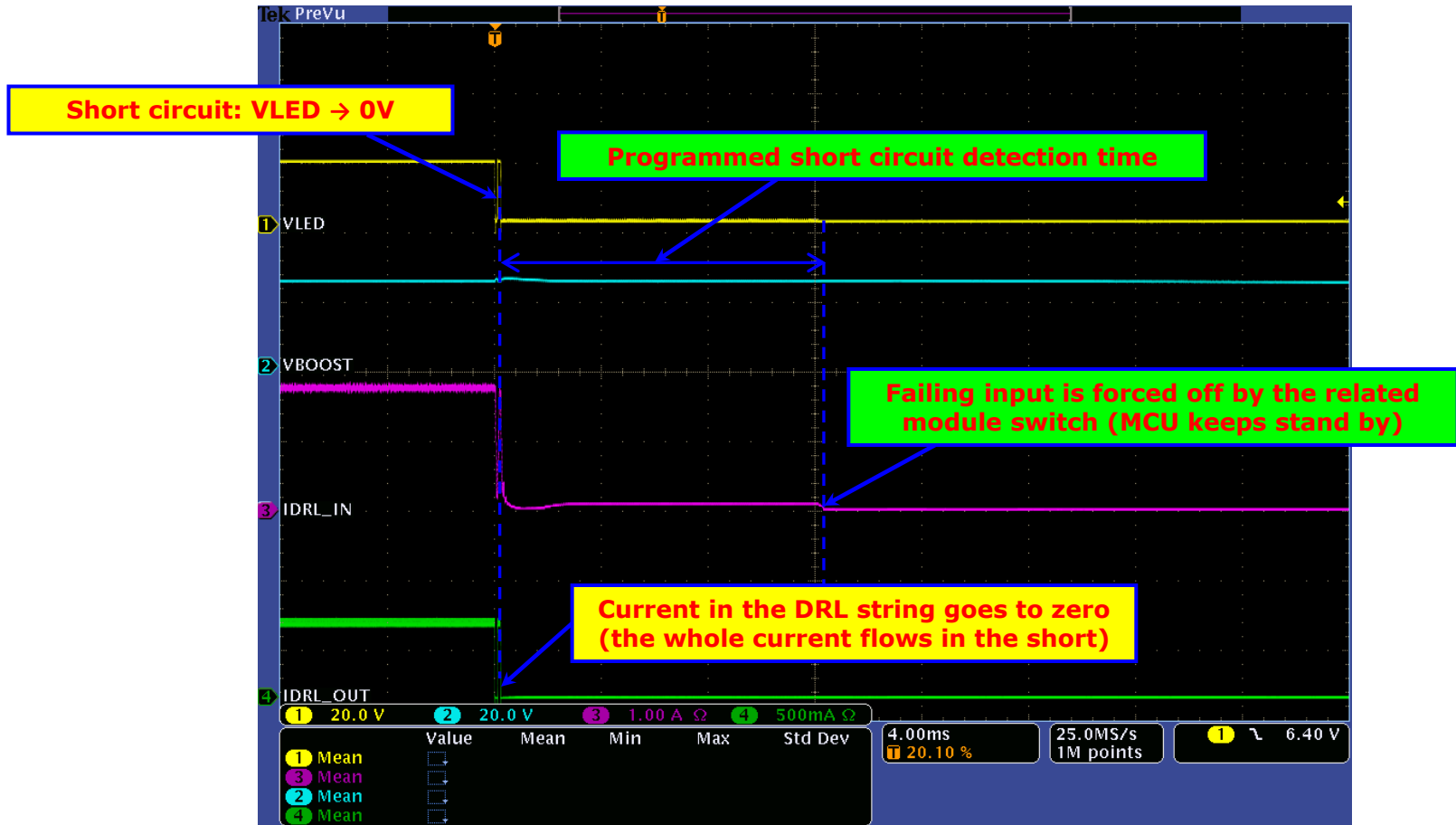

ISO 7637 pulses (type 1)

- The LDM A module is validated through the standard ISO 7637 pulses. For what concerns pulse type 1, it is shown how it correctly restarts normal operation at each pulse iteration.

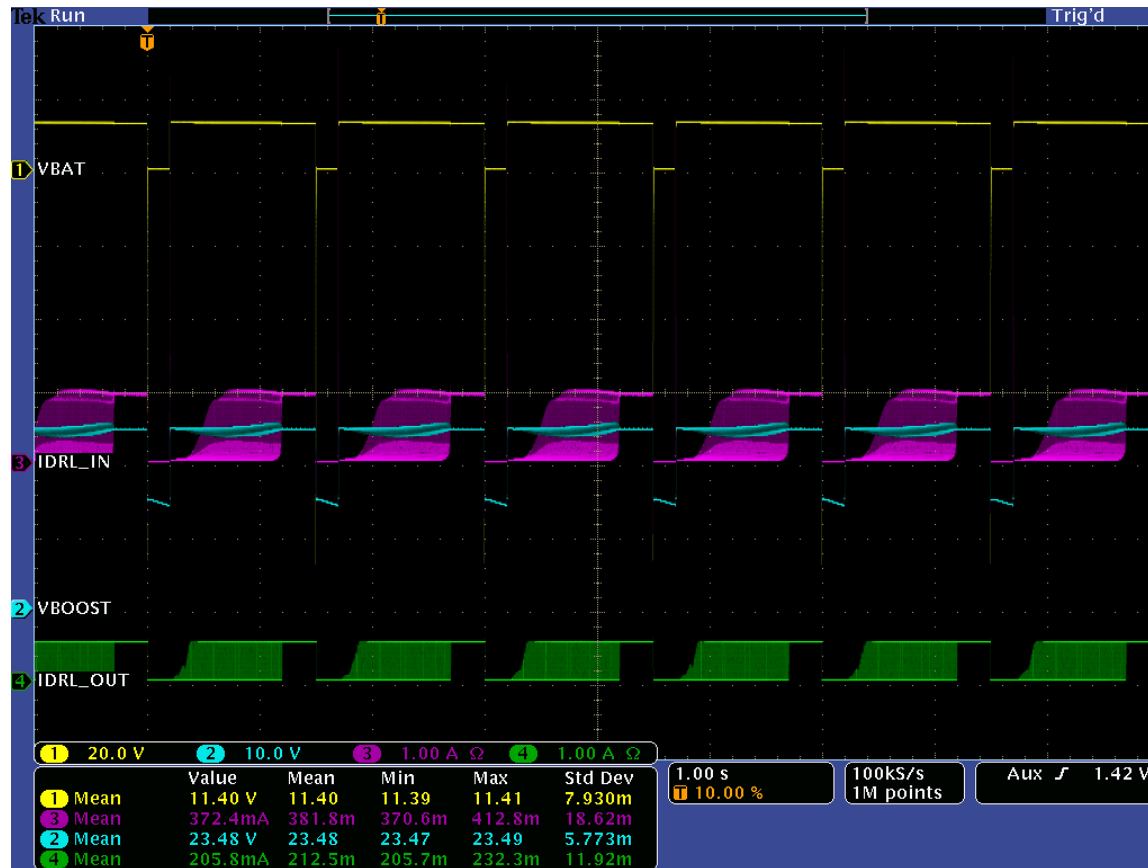

ISO 7637 pulses (type 1 - ZOOM)

- The module correctly restarts normal operation at each pulse iteration.
Note: No reset from the MCU.

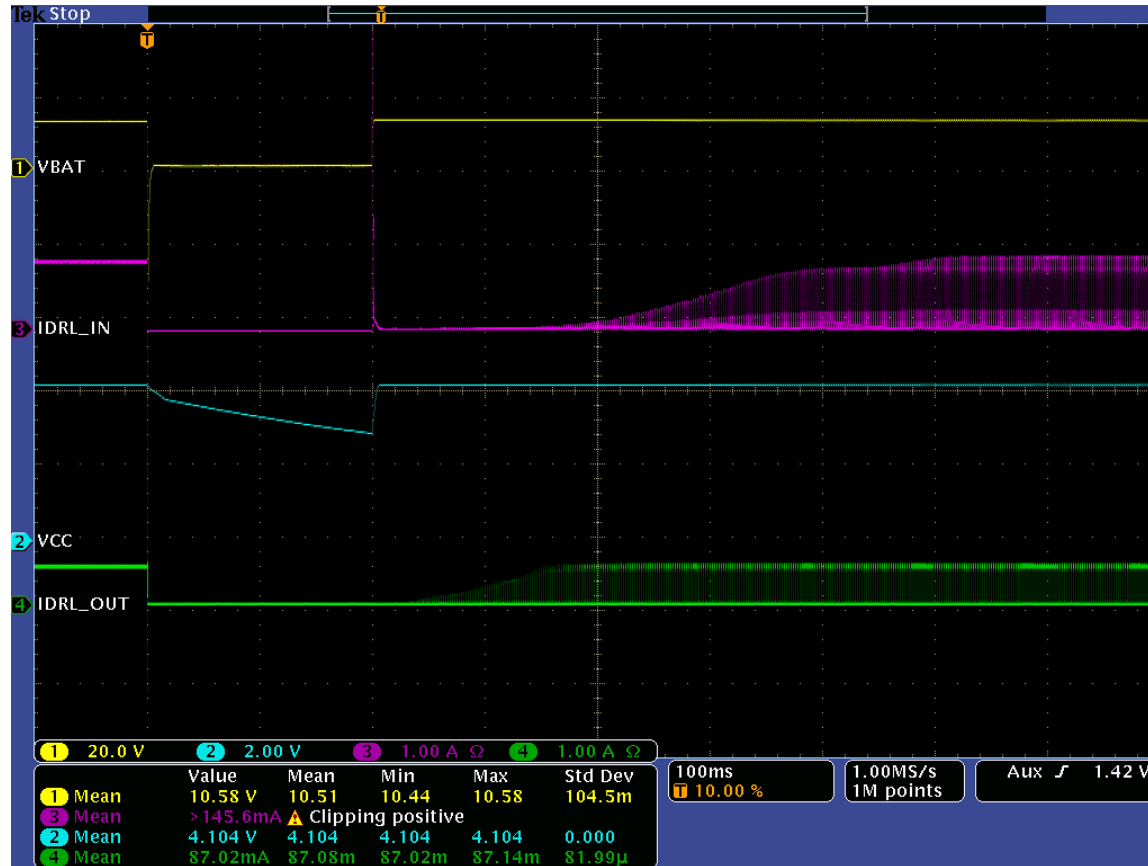

ISO 7637 pulses (type 2a)

- Also in this case, the module correctly restarts normal operation at each pulse iteration.

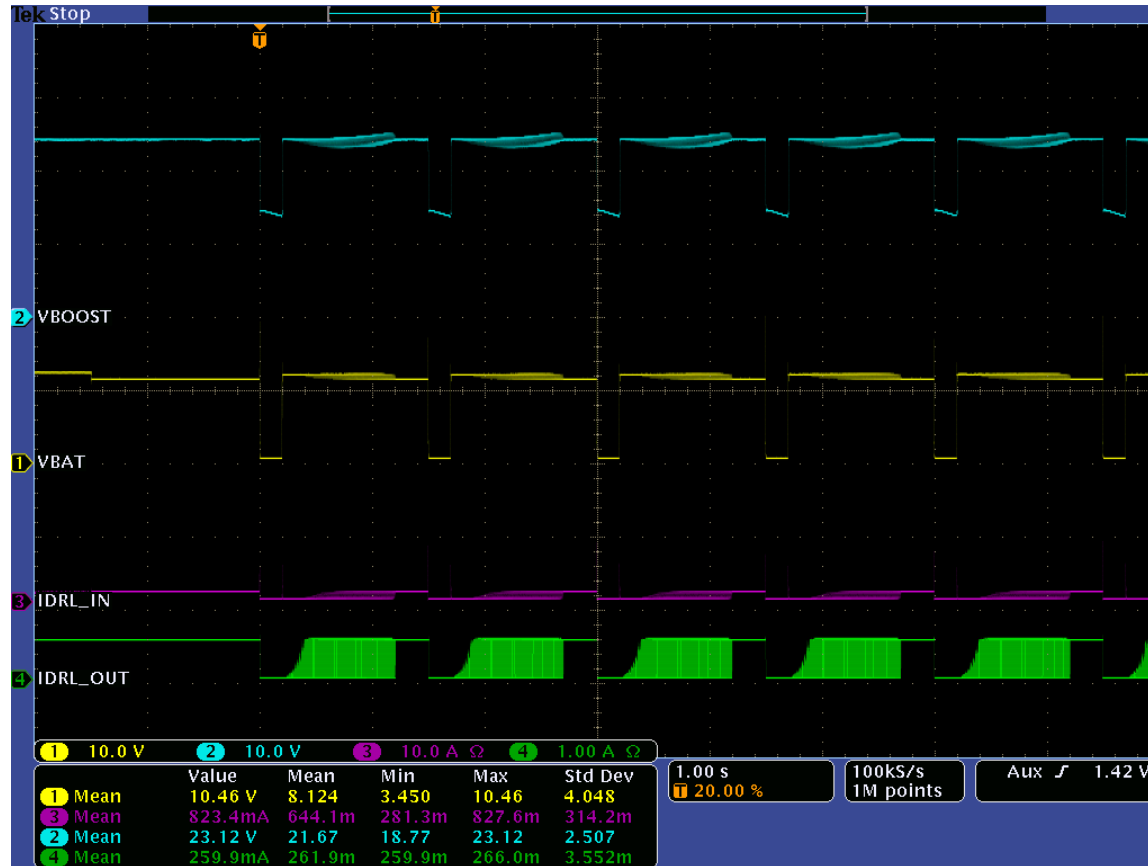

ISO 7637 pulses (type 3a)

- The highest amplitude disturbance (-150V) does not minimally affect the module operation.

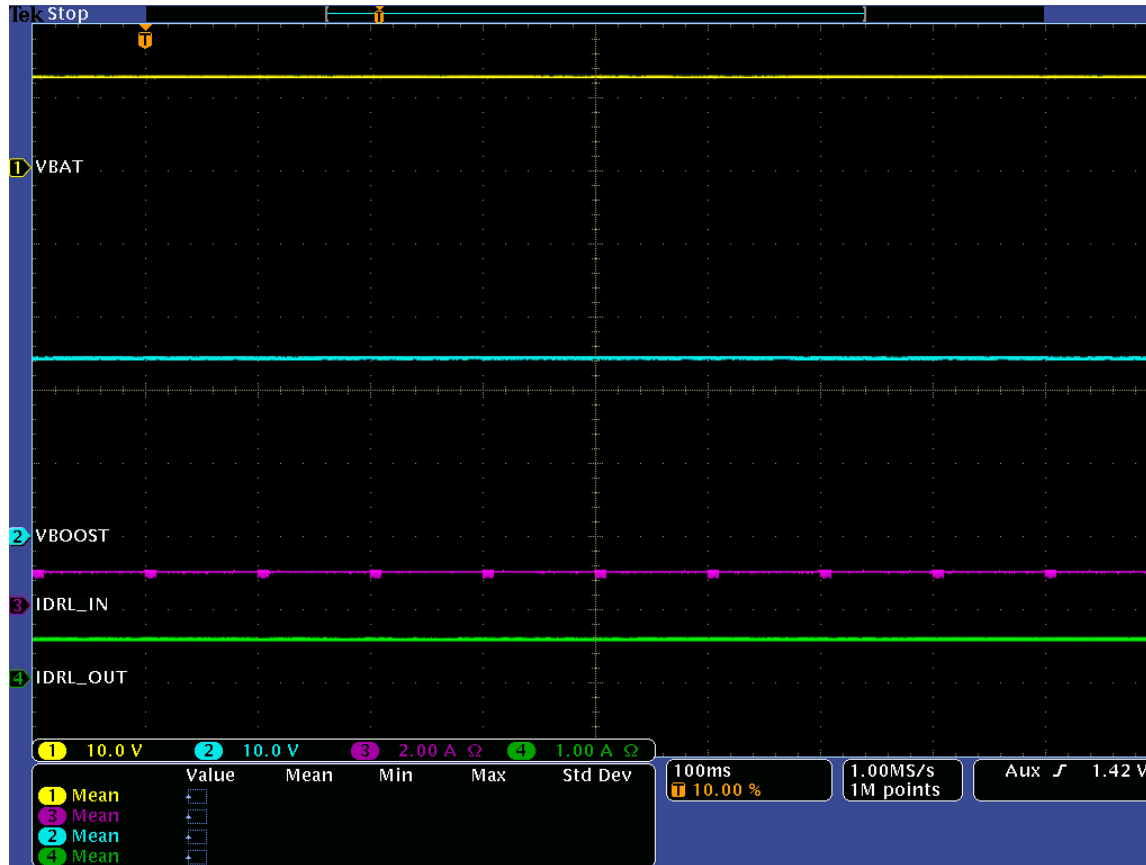

ISO 7637 pulses (type 3b)

- The highest disturbance (+150V) does not affect at all the module operation.



EMC conducted emission CISPR25

NCV78763 reference design board RFRD-A v1.1 (DRL & TI inputs powered)

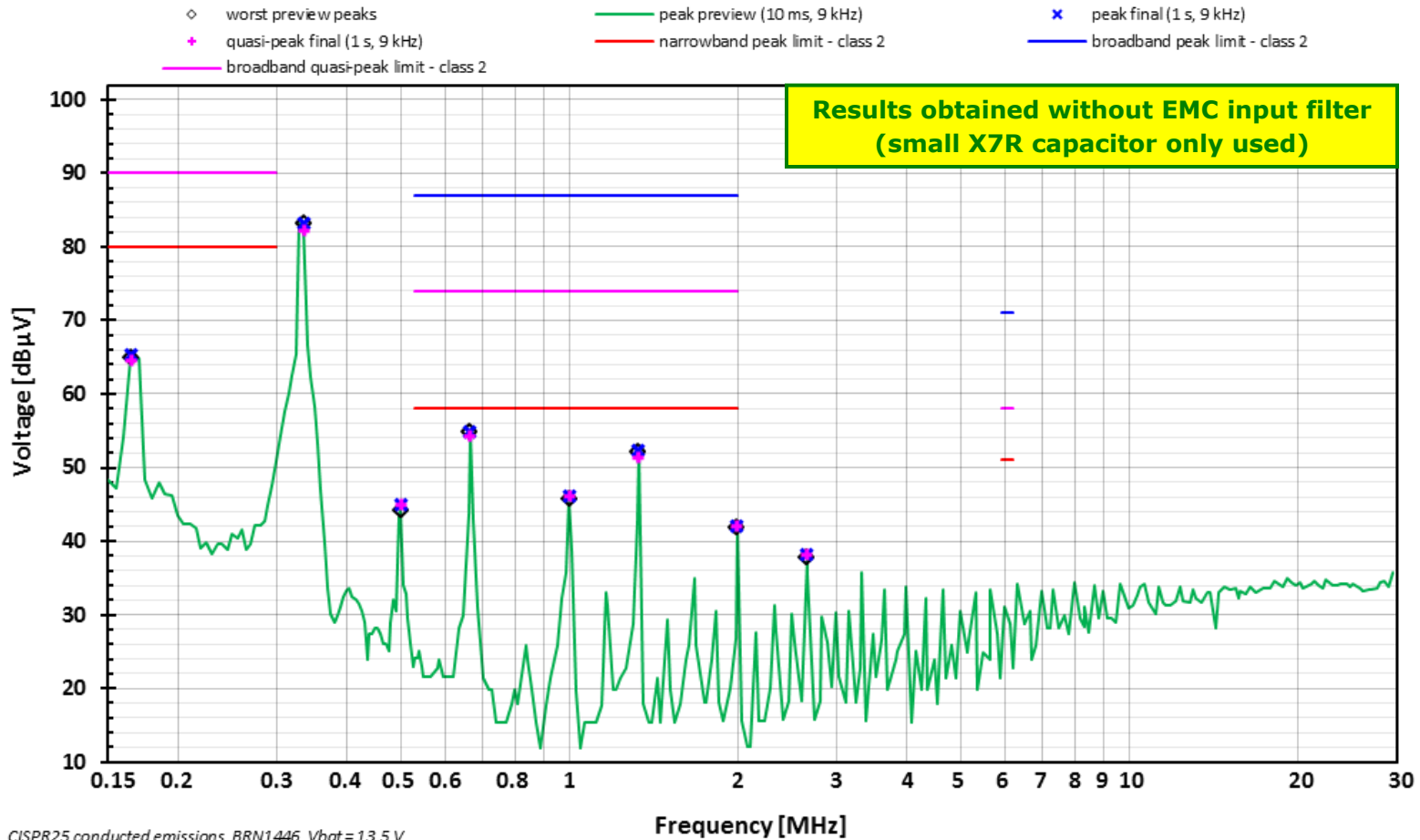

CISPR25 conducted emissions, BRN1446, Vbat = 13.5 V



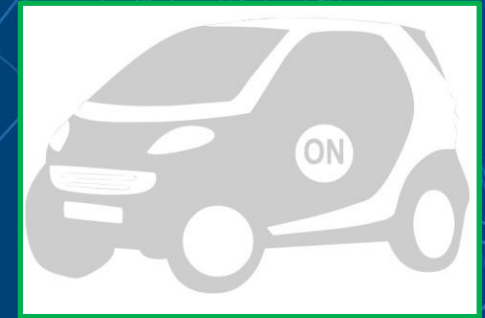
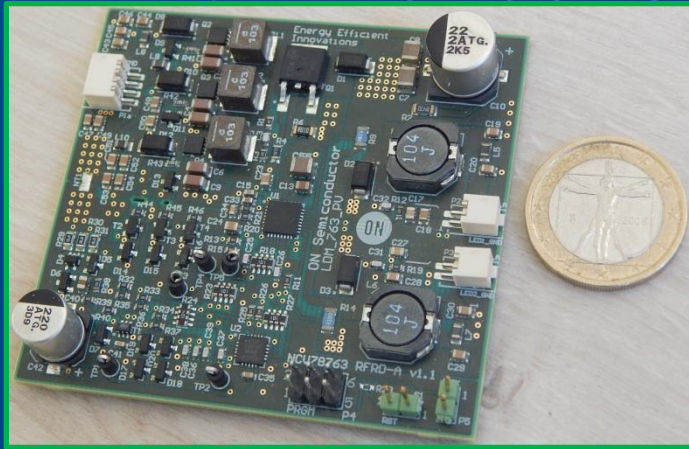

ON Semiconductor®

LED FRONTLIGHTING SOLUTIONS AAB

NCV78763 LDM A – QUICK START GUIDE - OVERVIEW

Any question or advice?

Our staff will be glad to provide all necessary information and collect your valuable inputs.



Confidential

ON Semiconductor®



Компания «Life Electronics» занимается поставками электронных компонентов импортного и отечественного производства от производителей и со складов крупных дистрибьюторов Европы, Америки и Азии.

С конца 2013 года компания активно расширяет линейку поставок компонентов по направлению коаксиальный кабель, кварцевые генераторы и конденсаторы (керамические, пленочные, электролитические), за счёт заключения дистрибьюторских договоров

Мы предлагаем:

- Конкурентоспособные цены и скидки постоянным клиентам.
- Специальные условия для постоянных клиентов.
- Подбор аналогов.
- Поставку компонентов в любых объемах, удовлетворяющих вашим потребностям.
- Приемлемые сроки поставки, возможна ускоренная поставка.
- Доставку товара в любую точку России и стран СНГ.
- Комплексную поставку.
- Работу по проектам и поставку образцов.
- Формирование склада под заказчика.
- Сертификаты соответствия на поставляемую продукцию (по желанию клиента).
- Тестирование поставляемой продукции.
- Поставку компонентов, требующих военную и космическую приемку.
- Входной контроль качества.
- Наличие сертификата ISO.

В составе нашей компании организован Конструкторский отдел, призванный помогать разработчикам, и инженерам.

Конструкторский отдел помогает осуществить:

- Регистрацию проекта у производителя компонентов.
- Техническую поддержку проекта.
- Защиту от снятия компонента с производства.
- Оценку стоимости проекта по компонентам.
- Изготовление тестовой платы монтаж и пусконаладочные работы.



Тел: +7 (812) 336 43 04 (многоканальный)

Email: org@lifeelectronics.ru