

Product Specification

56Gbps 60/100m QSFP+ Optical Transceiver Module

FTL414QB2C

PRODUCT FEATURES

- Four-channel full-duplex transceiver module
- Hot Pluggable QSFP+ form factor
- Maximum link length of 60m on OM3 Multimode Fiber (MMF) and 100m on OM4 MMF
- Up to 14.0625 Gb/s per channel
- Unretimed XLPP electrical interface
- Maximum power dissipation <1.5W
- Reliable VCSEL array technology
- Extended operating case temperature range: 0°C to 70°C
- Single 1x12 MPO receptacle
- RoHS-6 Compliant

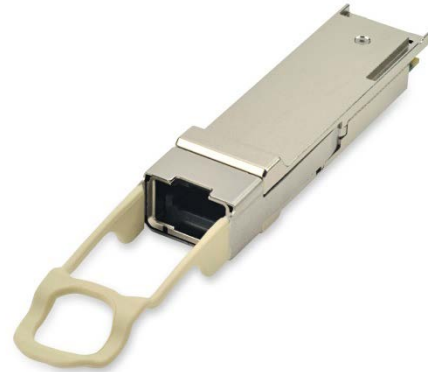

APPLICATIONS

- Infiniband 4xFDR
- Infiniband 4xFDR10
- Infiniband 4xQDR
- SAS 2.1/3.0
- IEEE 40GBASE-SR4

Finisar's FTL414QB2C QSFP+ transceiver modules are designed for use in Ethernet, SAS, and Infiniband links over multimode fiber. They are compliant with the QSFP+ MSA^{1,2} and the Ethernet³, SAS and InfiniBand⁴ architecture specifications. The optical transceiver is compliant per the RoHS Directive 2011/65/EU⁵. See Finisar Application Note AN-2038 for more details⁶.

PRODUCT SELECTION

FTL414QB2C

I. Pin Descriptions

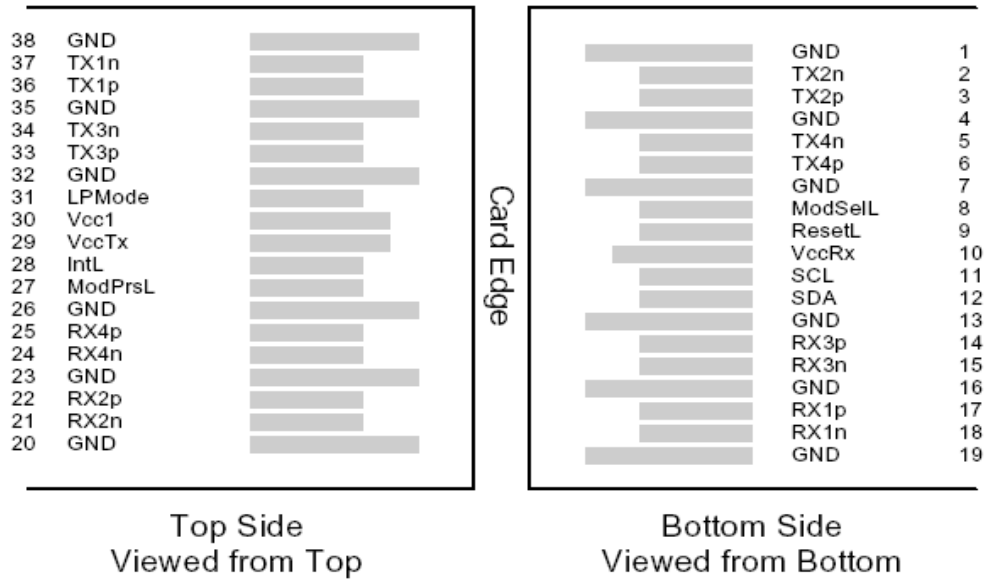

Figure 1 – QSFP+ MSA-compliant 38-pin connector

Pin	Symbol	Name/Description	Notes
1	GND	Ground	1
2	Tx2n	Transmitter Inverted Data Input	
3	Tx2p	Transmitter Non-Inverted Data Input	
4	GND	Ground	1
5	Tx4n	Transmitter Inverted Data Input	
6	Tx4p	Transmitter Non-Inverted Data Input	
7	GND	Ground	1
8	ModSelL	Module Select	
9	ResetL	Module Reset	
10	Vcc Rx	+3.3 V Power supply receiver	
11	SCL	2-wire serial interface clock	
12	SDA	2-wire serial interface data	
13	GND	Ground	1
14	Rx3p	Receiver Non-Inverted Data Output	
15	Rx3n	Receiver Inverted Data Output	
16	GND	Ground	1
17	Rx1p	Receiver Non-Inverted Data Output	
18	Rx1n	Receiver Inverted Data Output	
19	GND	Ground	1
20	GND	Ground	1
21	Rx2n	Receiver Inverted Data Output	
22	Rx2p	Receiver Non-Inverted Data Output	
23	GND	Ground	1
24	Rx4n	Receiver Inverted Data Output	
25	Rx4p	Receiver Non-Inverted Data Output	
26	GND	Ground	1

27	ModPrsL	Module Present	
28	IntL	Interrupt	
29	Vcc Tx	+3.3 V Power supply transmitter	
30	Vcc1	+3.3 V Power Supply	
31	LPMoDe	Low Power Mode	
32	GND	Ground	1
33	Tx3p	Transmitter Non-Inverted Data Input	
34	Tx3n	Transmitter Inverted Data Input	
35	GND	Ground	1
36	Tx1p	Transmitter Non-Inverted Data Input	
37	Tx1n	Transmitter Inverted Data Input	
38	GND	Ground	1

Notes

1. Circuit ground is internally isolated from chassis ground.

II. General Product Characteristics

Parameter	Value	Unit	Notes
Module Form Factor	QSFP+		
Number of Lanes	4 Tx and 4 Rx		
Maximum Aggregate Data Rate	56.25	Gb/s	
Maximum Data Rate per Lane	14.0625	Gb/s	Higher bit rates may be supported. Please contact Finisar.
Protocols Supported	40GBASE-SR4; SAS 2.1, 3.0 ; Infiniband QDR, FDR10, and FDR		
Electrical Interface and Pin-out	38-pin edge connector		Pin-out as defined by the QSFP+ MSA
Maximum Power Consumption per End	1.3	Watts	Varies with output voltage swing and pre-emphasis settings (see Figure 2)
Management Interface	Serial, I2C-based, 400 kHz maximum frequency		As defined by the QSFP+ MSA

Data Rate Specifications	Symbol	Min	Typ	Max	Units	Ref.
Bit Rate per Lane	BR	1.0625		14.0625	Gb/sec	
Bit Error Ratio	BER			10^{-12}		1
Link distance on OM3 MMF	d			60	meters	
Link distance on OM4 MMF	d			100	meters	

Notes:

1. Tested with a PRBS $2^{31}-1$ test pattern.

III. Absolute Maximum Ratings

Parameter	Symbol	Min	Typ	Max	Unit	Ref.
Maximum Supply Voltage	V _{cc1} , V _{ccTx} , V _{ccRx}	-0.5		3.6	V	
Storage Temperature	T _S	-40		85	°C	
Case Operating Temperature	T _{OP}	0		70	°C	
Relative Humidity	RH	0		85	%	1
Damage Threshold, per Lane	DT	3.4			dBm	

Notes:

1. Non-condensing.

IV. Electrical Characteristics (T_{OP} = 0 to 70°C, V_{CC} = 3.15 to 3.45 Volts)

Parameter	Symbol	Min	Typ	Max	Unit	Ref.
Supply Voltage	V _{cc1} , V _{ccTx} , V _{ccRx}	3.135		3.465	V	
Supply Current	I _{cc}			350	mA	
Link turn-on time						
Transmit turn-on time				2000	ms	2
Transmitter (per Lane)						
Single ended input voltage tolerance	V _{inT}	-0.3		4.0	V	
Differential data input swing	V _{in,pp}	200		1200	mV _{pp}	3
Differential input threshold			50		mV	
AC common mode input voltage tolerance (RMS)		15			mV	
Differential input return loss			Per IEEE P802.3ba, Section 86A.4.1.1		dB	4
J2 Jitter Tolerance	J _{t2}	0.16			UI	
J9 Jitter Tolerance	J _{t9}	0.29			UI	
Data Dependent Pulse Width Shrinkage	DDPWS	0.07			UI	
Eye mask coordinates {X1, X2 Y1, Y2}			0.11, 0.31 95, 350		UI mV	5
Receiver (per Lane)						
Single-ended output voltage		-0.3		4.0	V	
Differential data output swing	V _{out,pp}	0		800	mV _{pp}	5,6
Differential output amplitude settings 00		200		400	mV	6
Differential output amplitude settings 01		300		600	mV	6
Differential output amplitude settings 10		400		800	mV	6
Differential output amplitude settings 11		600		1200	mV	6
Output pre-emphasis setting 00			0		mV	6
Output pre-emphasis setting 01			125		mV	6
Output pre-emphasis setting 10			175		mV	6
Output pre-emphasis setting 11			325		mV	6
AC common mode output voltage (RMS)				7.5	mV	
Termination mismatch at 1 MHz				5	%	
Differential output return loss			Per IEEE P802.3ba, Section 86A.4.2.1		dB	4

Common mode output return loss		Per IEEE P802.3ba, Section 86A.4.2.2			dB	4
Output transition time, 20% to 80%		28			ps	
J2 Jitter output	Jo2			0.42	UI	
J9 Jitter output	Jo9			0.65	UI	
Eye mask coordinates {X1, X2 Y1, Y2} range 0		0.29, 0.5 50, 225			UI mV	7
Eye mask coordinates {X1, X2 Y1, Y2} range1		0.29,0.5 100,350			UI mV	7
Eye mask coordinates {X1, X2 Y1, Y2} range2		0.29,0.5 150,450			UI mV	7
Power Supply Ripple Tolerance	PSR	50			mVpp	

Notes:

1. Maximum total power value is specified across the full temperature and voltage range.
2. From power-on and end of any fault conditions.
3. After internal AC coupling. Self-biasing 100Ω differential input.
4. 10 MHz to 11.1 GHz range
5. AC coupled with 100Ω differential output impedance.
6. Settable via the I2C interface.
7. Hit ratio = 5 x 10E-5.

V. Optical Characteristics (T_{OP} = 0 to 70°C, V_{CC} = 3.15 to 3.45 Volts)

Parameter	Symbol	Min	Typ	Max	Unit	Ref.
Transmitter (per Lane)						
Signaling Speed per Lane		1.0625		14.0625	GBd	1
Center wavelength		840		860	nm	
RMS Spectral Width	SW			0.55	nm	
Average Launch Power per Lane	TXP _x	-6.0			dBm	
Transmit OMA per Lane	TxOMA	-4.5		3.0	dBm	2
Difference in Power between any two lanes [OMA]	DP _x			2.0	dB	
Peak Power per Lane	PP _x			4.0	dBm	
Optical Extinction Ratio	ER	4.7			dB	
Optical Return Loss Tolerance	ORL			12	dB	
Encircled Flux	FLX	> 86% at 19 um < 30% at 4.5 um			dBm	
Average launch power of OFF transmitter, per lane				-30	dBm	
Relative Intensity Noise	RIN			-128	dB/Hz	
Transmitter eye mask definition {X1, X2, X3, Y1, Y2, Y3}		0.23, 0.34, 0.43, 0.27, 0.35, 0.4				

Parameter	Symbol	Min	Typ	Max	Unit	Ref.
Receiver (per Lane)						
Signaling Speed per Lane		1.0625		14.0625	GBd	3
Center wavelength		840		860	nm	
Damage Threshold	DT	3.4			dBm	
Average Receive Power per Lane	RXP _x			2.4	dBm	
Receiver Sensitivity (OMA) per Lane	URS			-8.2	dBm	
Peak Power, per lane	PP _x			4	dBm	
Receiver Reflectance	Rfl			-12	dB	
Vertical eye closure penalty, per lane				1.9	dB	
Stressed eye J2 jitter, per Lane				0.3	UI	
Stressed eye J9 jitter, per Lane				0.47	UI	
Rx jitter tolerance: Jitter frequency and p-p amplitude		(75, 5)			kHz, UI	
		(375, 1)			kHz, UI	
LOS De-Assert	LOS _D			-12	dBm	
LOS Assert	LOS _A	-30			dBm	
LOS Hysteresis		0.5			dBm	

Notes:

1. Transmitter consists of 4 lasers operating at a maximum rate of 14.0625Gb/s each.
2. Even if TDP is <0.9dB, the OMA min must exceed this value.
3. Receiver consists of 4 photodetectors operating at a maximum rate of 14.0625Gb/s each.

VI. Memory Map and Control Registers

Compatible with SFF-8436 Rev. 4.7 (QSFP+). Please see Finisar Application Note AN-2079.⁷

VII. Environmental Specifications

Finisar FTL414QB2C transceivers have an operating temperature range from 0°C to +70°C case temperature.

Environmental Specifications	Symbol	Min	Typ	Max	Units	Ref.
Case Operating Temperature	T _{op}	0		70	°C	
Storage Temperature	T _{sto}	-40		85	°C	

VIII. Regulatory Compliance

Finisar FTL414QB2C transceivers are RoHS-6 Compliant. Copies of certificates are available at Finisar Corporation upon request.

FTL414QB2C transceiver modules are Class 1 laser eye safety compliant per IEC 60825-1.

IX. Mechanical Specifications

The FTL414QB2C mechanical specifications are compliant to the QSFP+ MSA transceiver module specifications.

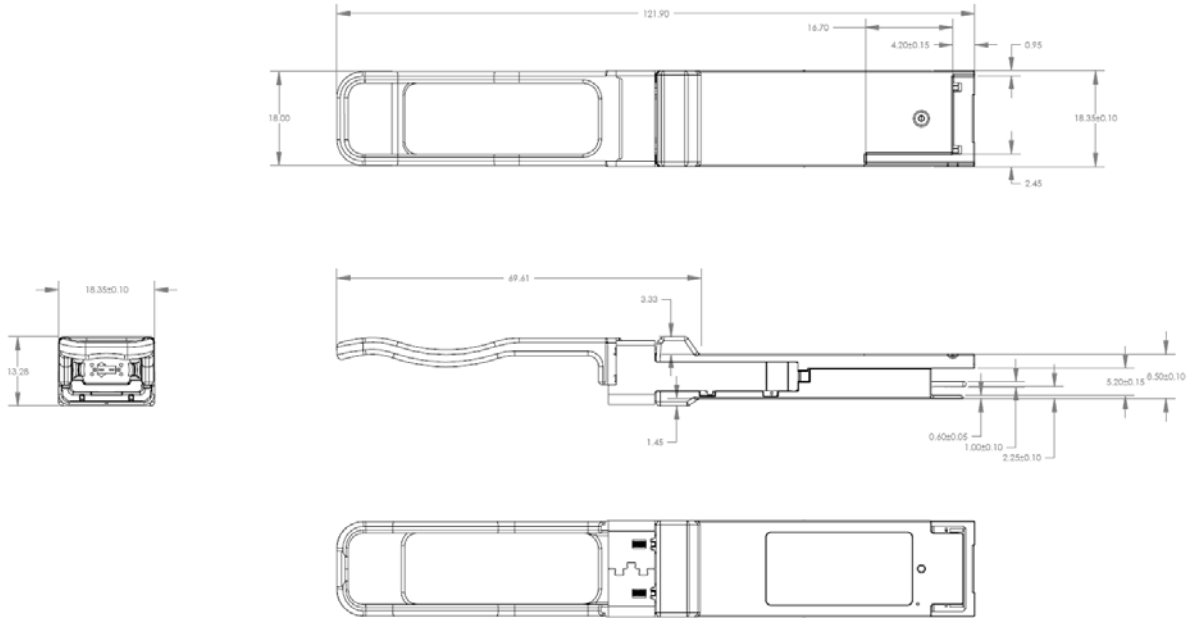
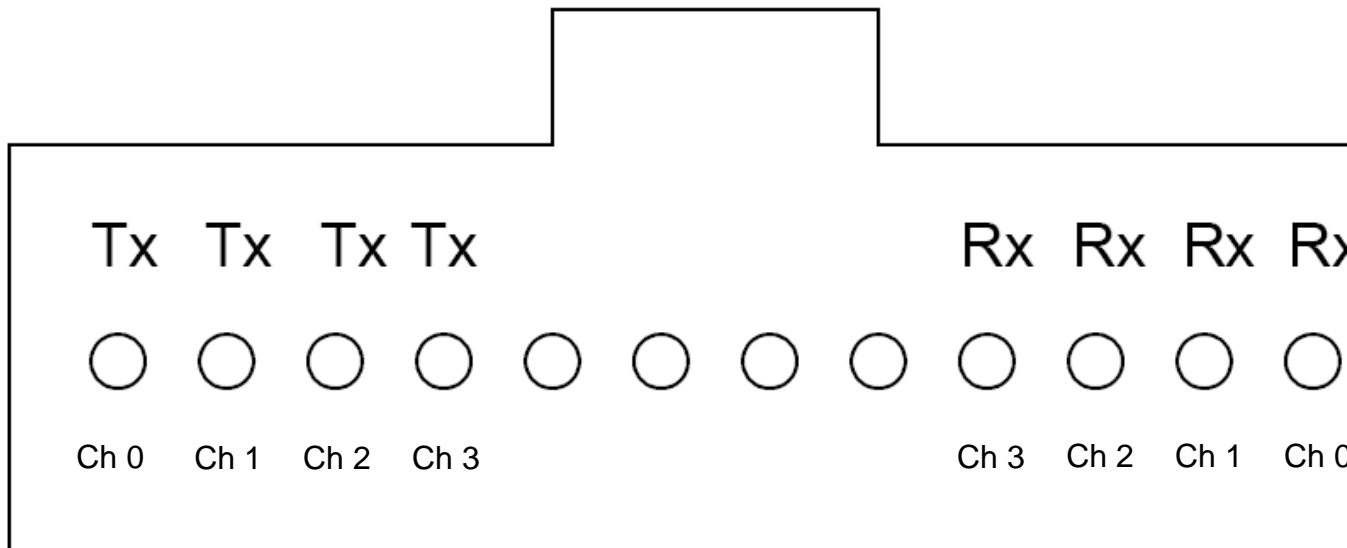

Figure 2 – FTL414QB2C mechanical drawing

[Label Image to be inserted here]

Figure 3 – FTL414QB2C product label



**Figure 4 – FTL414QB2C optical lane assignment
(front view of MPO receptacle)**

X. References

1. INF-8438i – Specification for QSFP (Quad Small Formfactor Pluggable) Transceiver, Rev 1.0, November 2006.
2. SFF-8436 – Specification for QSFP+ Copper and Optical Transceiver, Rev 4.8, October 2013.
3. IEEE 802.3ba – PMD Type 40GBASE-SR4.
4. InfiniBand™ Architecture Specification Volume 2, Release 1.3, November 6, 2012.
5. Directive 2011/65/EU of the European Council Parliament and of the Council, “on the restriction of the use of certain hazardous substances in electrical and electronic equipment”. Certain products may use one or more exemptions as allowed by the Directive.
6. “Application Note AN-2038: Finisar Implementation of RoHS Compliant Transceivers”.
7. “Application Note AN-2079: QSFP Module EEPROM Mapping”, Rev. G, Finisar Corporation, May, 2013.

XI. For More Information

Finisar Corporation
1389 Moffett Park Drive
Sunnyvale, CA 94089-1133
Tel. 1-408-548-1000
Fax 1-408-541-6138
sales@finisar.com
www.finisar.com

Компания «Life Electronics» занимается поставками электронных компонентов импортного и отечественного производства от производителей и со складов крупных дистрибьюторов Европы, Америки и Азии.

С конца 2013 года компания активно расширяет линейку поставок компонентов по направлению коаксиальный кабель, кварцевые генераторы и конденсаторы (керамические, пленочные, электролитические), за счёт заключения дистрибьюторских договоров

Мы предлагаем:

- Конкурентоспособные цены и скидки постоянным клиентам.
- Специальные условия для постоянных клиентов.
- Подбор аналогов.
- Поставку компонентов в любых объемах, удовлетворяющих вашим потребностям.
- Приемлемые сроки поставки, возможна ускоренная поставка.
- Доставку товара в любую точку России и стран СНГ.
- Комплексную поставку.
- Работу по проектам и поставку образцов.
- Формирование склада под заказчика.
- Сертификаты соответствия на поставляемую продукцию (по желанию клиента).
- Тестирование поставляемой продукции.
- Поставку компонентов, требующих военную и космическую приемку.
- Входной контроль качества.
- Наличие сертификата ISO.

В составе нашей компании организован Конструкторский отдел, призванный помогать разработчикам, и инженерам.

Конструкторский отдел помогает осуществить:

- Регистрацию проекта у производителя компонентов.
- Техническую поддержку проекта.
- Защиту от снятия компонента с производства.
- Оценку стоимости проекта по компонентам.
- Изготовление тестовой платы монтаж и пусконаладочные работы.



Тел: +7 (812) 336 43 04 (многоканальный)

Email: org@lifeelectronics.ru