

COBP PHOTO REFLECTOR with RED & IR LED

■ GENERAL DISCRIPTION

The NJL5501R is the compact surface mount type photo reflector, which is built in a RED LED, Infrared LED and a high sensitive detector. This product is suit for the application for Pulse Oximeter, Heart rate monitor.

■ FEATURES

- Peak wavelength : λ_p 660±3nm (RED) , 940±10nm (Infrared)
- High output current : 1000 to 4300μA typ (RED), 145 to 580μA typ (Infrared)
- Miniature, thin package: 1.9x2.6x0.8mm

■ APPLICATION

- Pulse Oximeter, Heart late monitor

■ ABSOLUTE MAXIMUM RATINGS (Ta=25°C)

PARAMETER	SYMBOL	RATINGS	UNIT
Emitter			
Forward Current (Continuous)	IF RED	30	mA
	IF IR	30	mA
Reverse Voltage (Continuous)	VR RED	5	V
	VR IR	5	V
Power Dissipation	PD	45	mW
Detector			
Collector-Emitter Voltage	VCEO	16	V
Emitter-Collector Voltage	VECO	6	V
Collector Current	IC	10	mA
Collector Power Dissipation	PC	25	mW
Coupled			
Total Power Dissipation	Ptot	60	mW
Operating Temperature	Topr	-20 to +85	°C
Storage Temperature	Tstg	-30 to +85	°C
Reflow Soldering Temperature	Tsol	260 peak	°C

■ ELECTRO-OPTICAL CHARACTERISTICS (Ta=25°C)

PARAMETER	SYMBOL	TEST CONDITION	MIN	TYP	MAX	UNIT
Emitter						
Forward Voltage	VF RED	IF=4mA	1.7	—	2.1	V
	VF IR	IF=4mA	1.0	—	1.3	V
Reverse Current	IR RED	VR=5V	—	—	5	μA
	IR IR	VR=5V	—	—	5	μA
Peak Wavelength *1	$\lambda_{p\text{RED}}$	IF=20mA	657	660	663	nm
	$\lambda_{p\text{IR}}$	IF=20mA	930	940	950	nm
Detector						
Dark Current	ICEO	VCE=10V	—	—	0.2	μA
Collector-Emitter Voltage	VCEO	IC=100μA	16	—	—	V
Coupled						
Output Current *2	IO RED	IF=4mA, VCE=2V, d=0.7mm	1000	—	4300	μA
	IO IR	IF=4mA, VCE=2V, d=0.7mm	145	—	580	μA
Operating Dark Current *3	ICEOD RED	IF=4mA, VCE=2V	—	—	5	μA
	ICEOD IR	IF=4mA, VCE=2V	—	—	1	μA
Response Time(Rise/Fall)	Tr, Tf	IO=100μA, VCE=2V, d=0.7mm, RL=1kΩ	—	20	—	μs

*1 This is represented as Emission wavelength range of LED. The emission wavelength verification test has not confirmed in the manufacturing process.

*2 Please refer to "Output Current Test Condition".

*3 ICEOD may increase according to the periphery situation of the surface mounted condition.

■ OUTLINE unit:mm

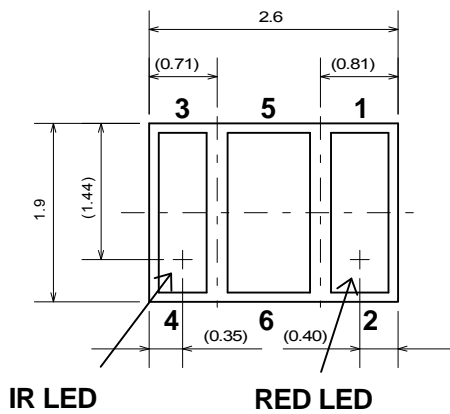

IR LED

RED LED



1. Cathode for RED LED
2. Anode for RED LED
3. Anode for Infrared LED
4. Cathode for Infrared LED
5. Collector
6. Emitter

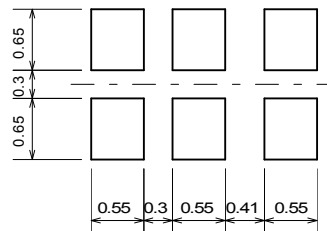
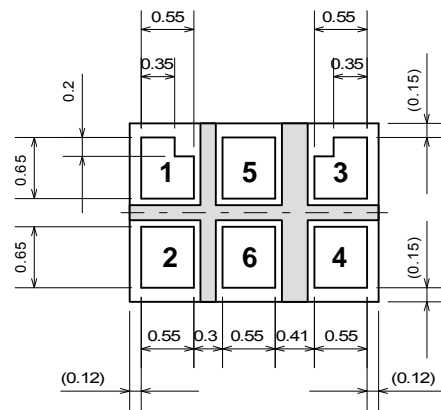

Example of solder pads dimensions

Unspecified tolerance : $\pm 0.1\text{mm}$

Dimensions in parenthesis are shown for reference.

■ BLOCK DIAGRAM

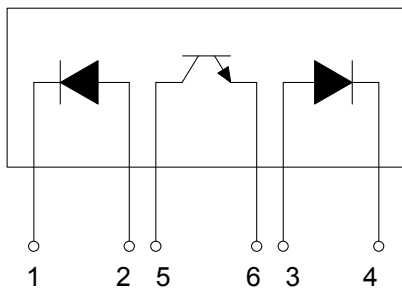

1. Cathode for RED LED
2. Anode for RED LED
5. Collector
6. Emitter
3. Anode for Infrared LED
4. Cathode for Infrared LED

■ OUTPUT CURRENT TEST CONDITION

The signal from LED is reflected at the aluminum surface.

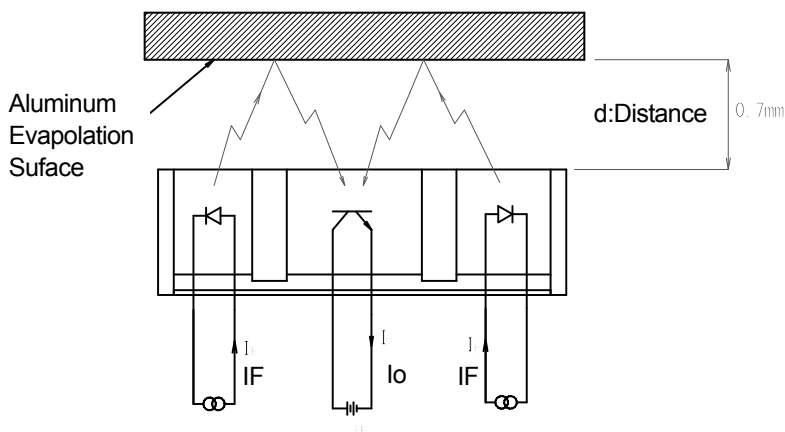

■ DARK CURRENT TEST CONDITION

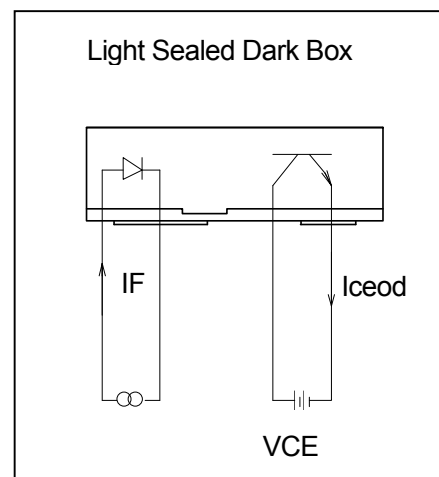

■ RESPONSE TIME TEST CONDITION

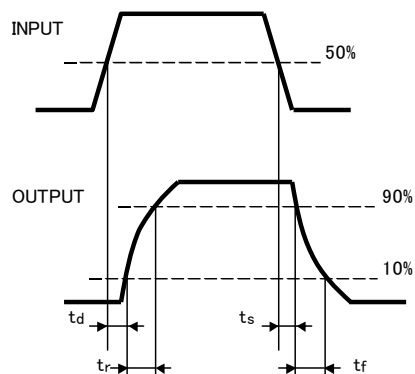
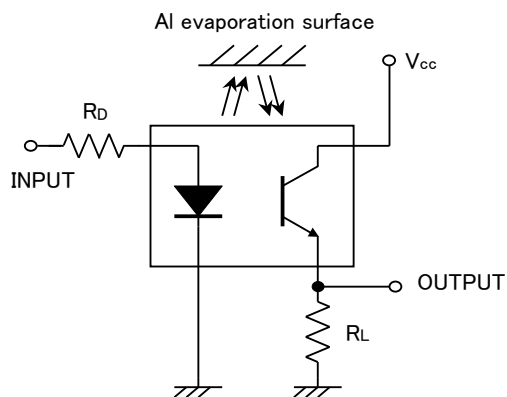

■ EDGE RESPONSE TEST CONDITION

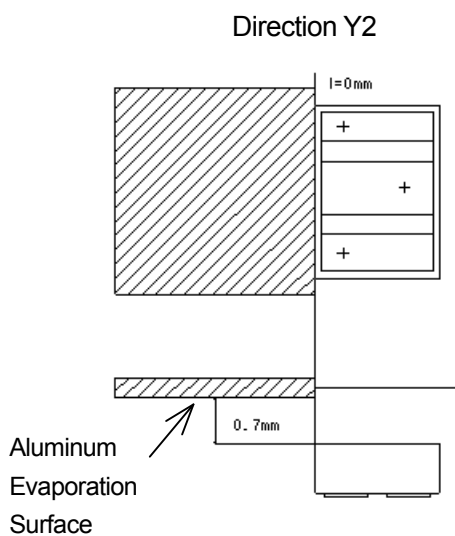
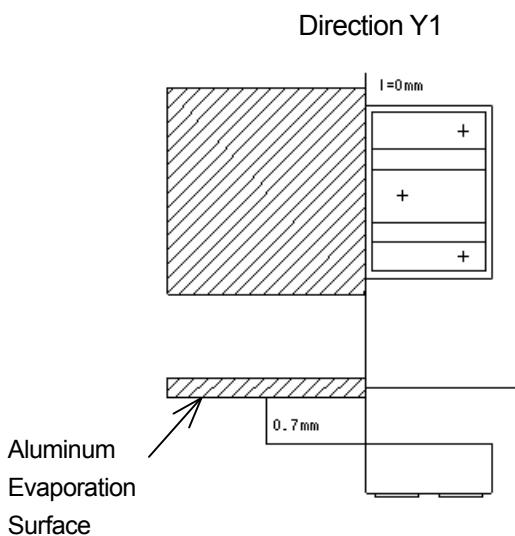
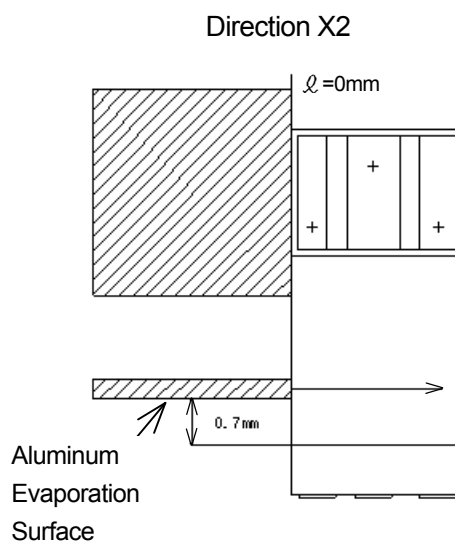
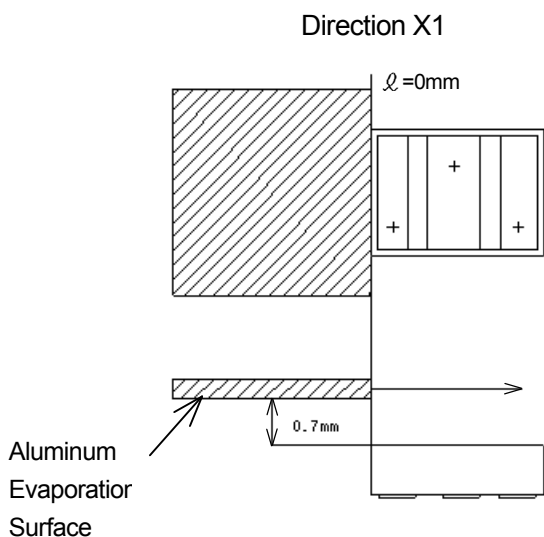

Power Dissipation vs. Temperature

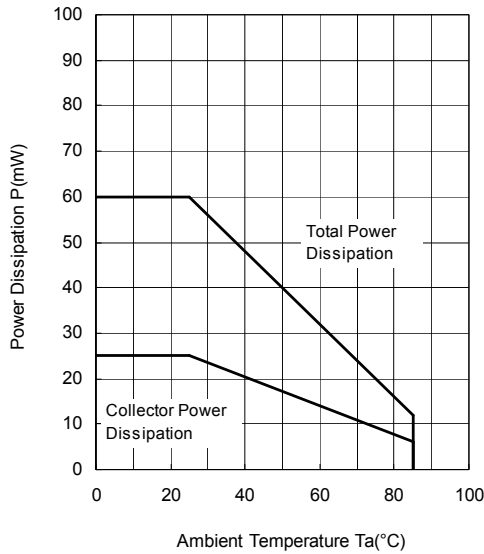

**Forward Current vs. Temperature
RED LED & IR LED**

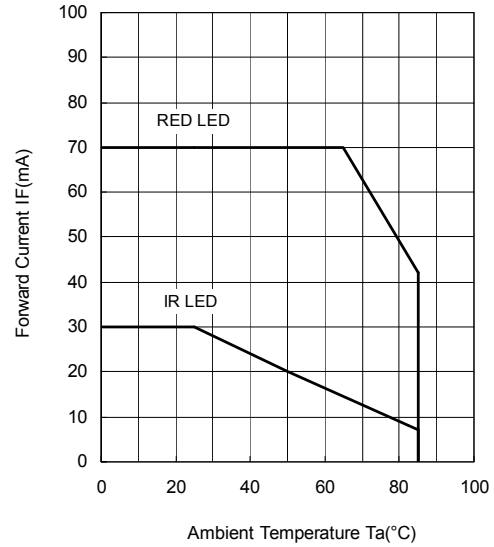

■ TYPICAL CHARACTERISTICS

**Forward Voltage vs. Forward Current
RED LED & IR LED**

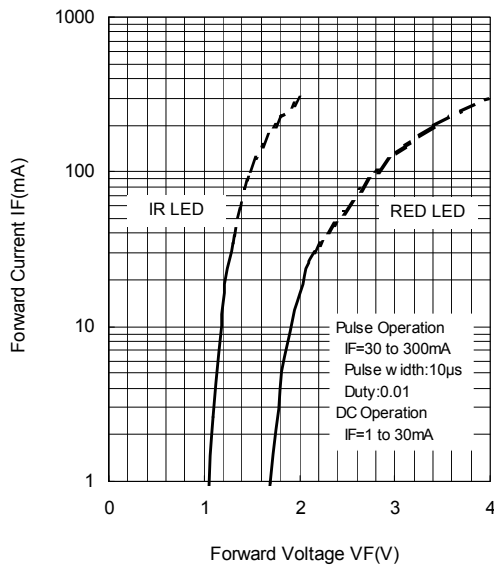

**Forward Voltage vs. Temperature
RED LED & IR LED**

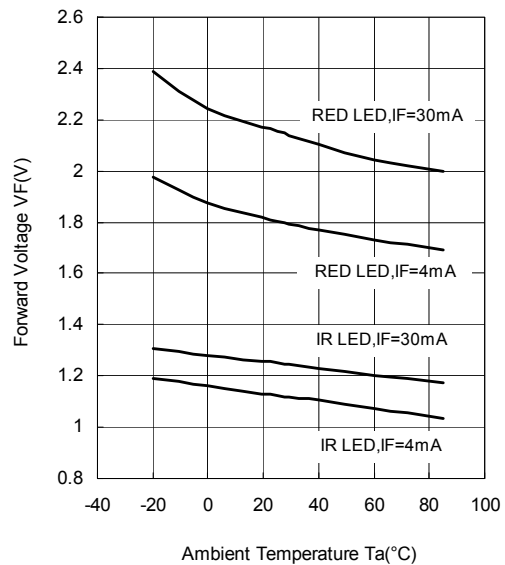

Dark Current vs. Temperature

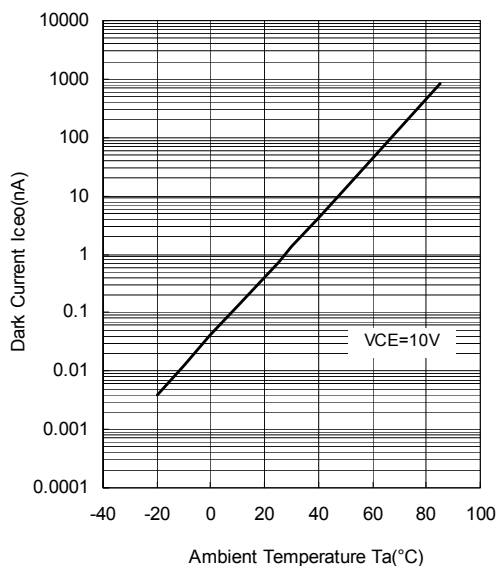

**Operating Dark Current vs. Temperature
RED LED & IR LED**

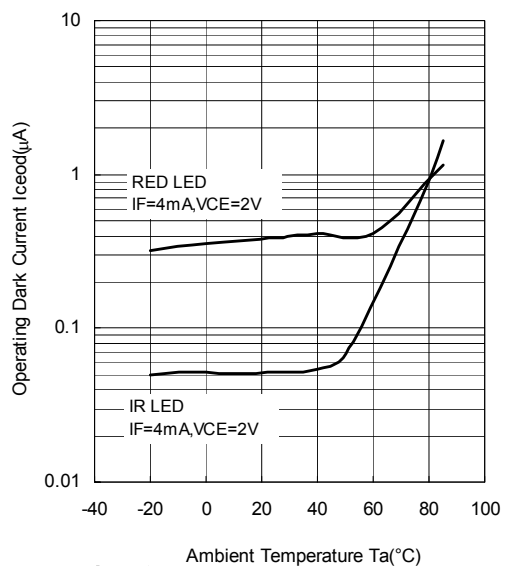

**Output Current vs. Forward Current
RED LED (Ta=25°C)**

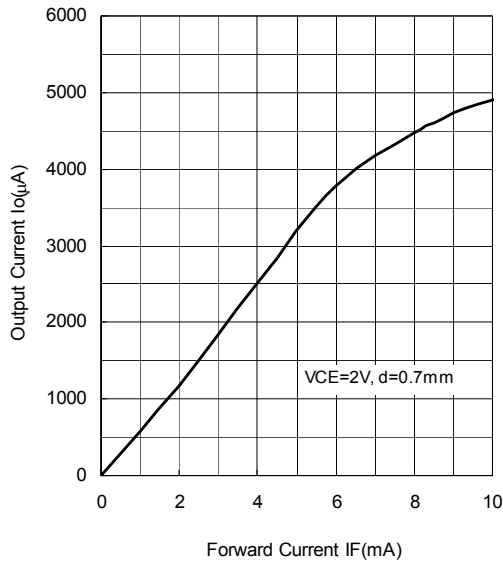

**Output Current vs. Forward Current
IR LED (Ta=25°C)**

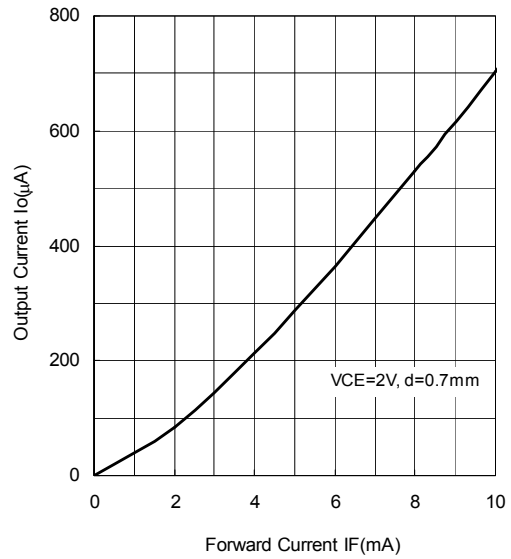

**Output Current vs. Temperature
RED LED**

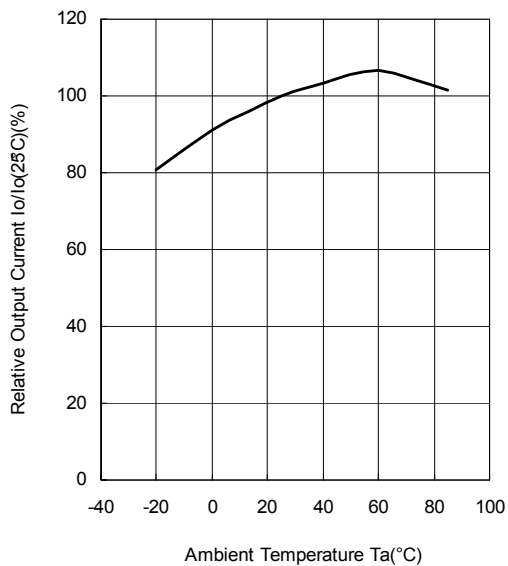

**Output Current vs. Temperature
IR LED**

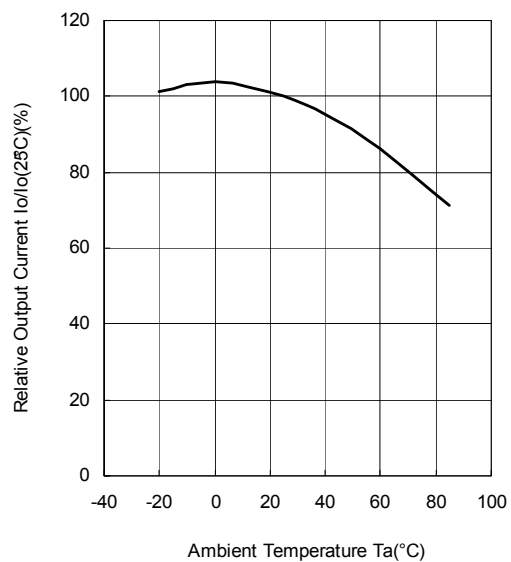

**Output Characteristics (Ta=25°C)
RED LED**

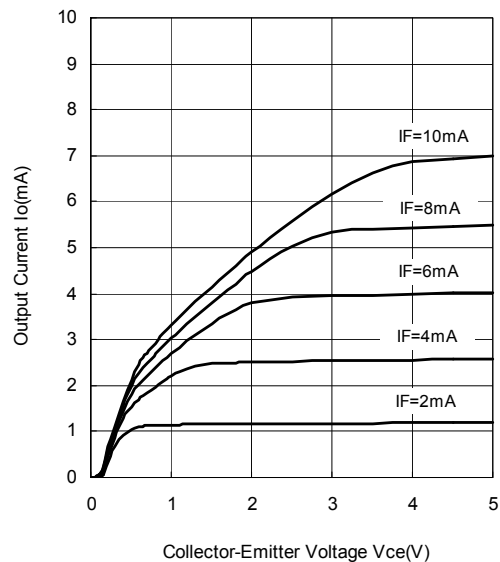

**Output Characteristics (Ta=25°C)
IR LED**

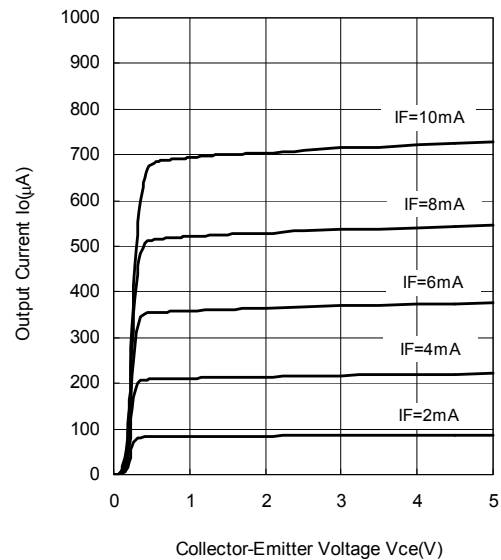

Vce Saturation (Ta=25°C)
RED LED

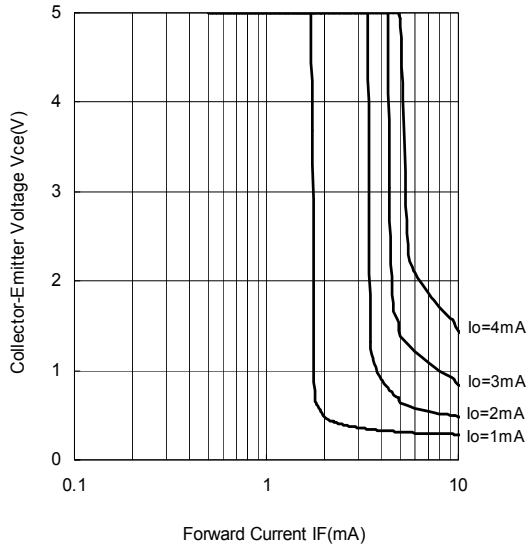

Vce Saturation (Ta=25°C)
IR LED

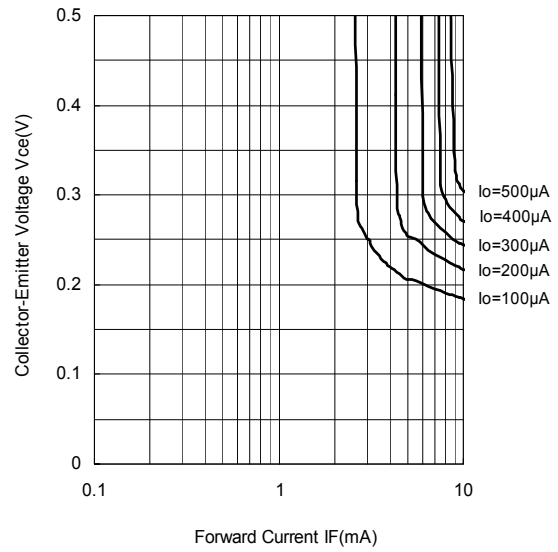

Output Current vs. Edge Distance
RED LED(Ta=25°C)

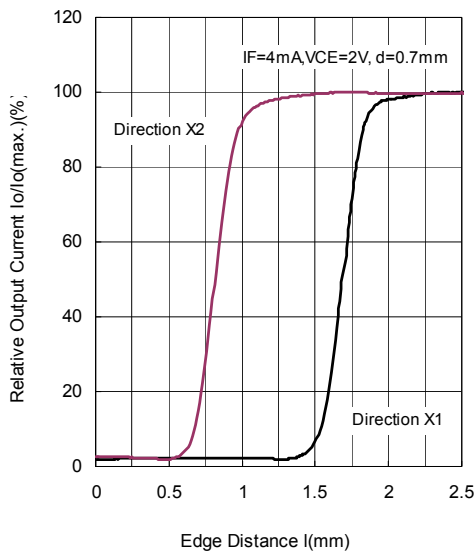

Output Current vs. Edge Distance
IR LED(Ta=25°C)

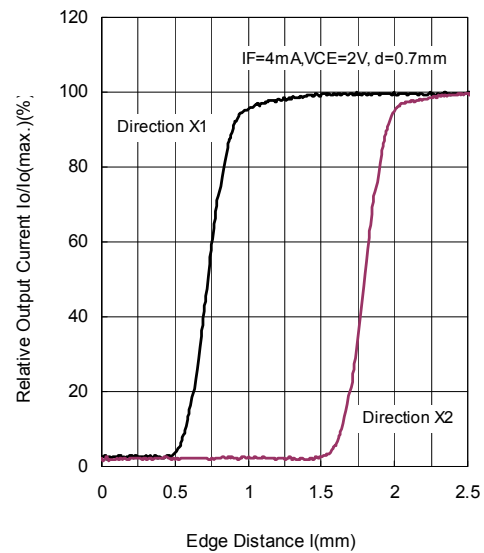

Output Current vs. Edge Distance
RED LED(Ta=25°C)

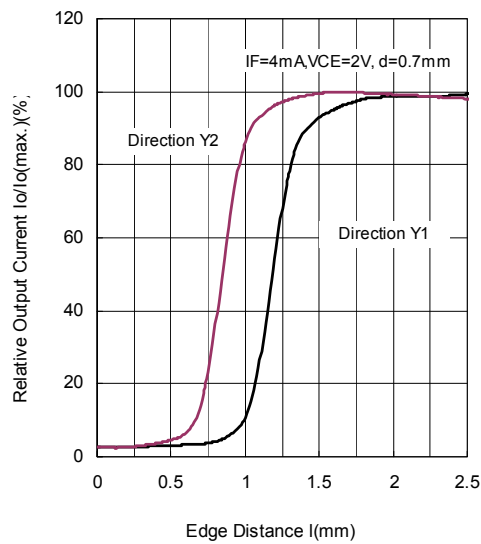

Output Current vs. Edge Distance
IR LED(Ta=25°C)

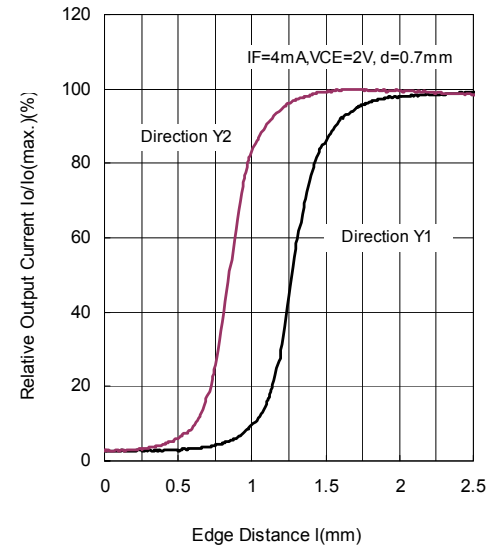

Output Current vs. Distance
RED LED(Ta=25°C)

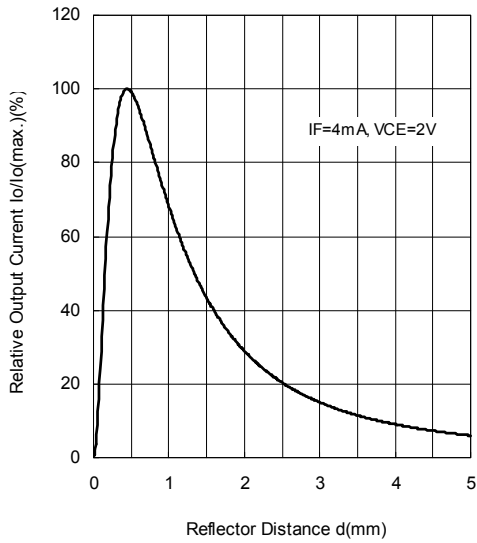

Output Current vs. Distance
IR LED(Ta=25°C)

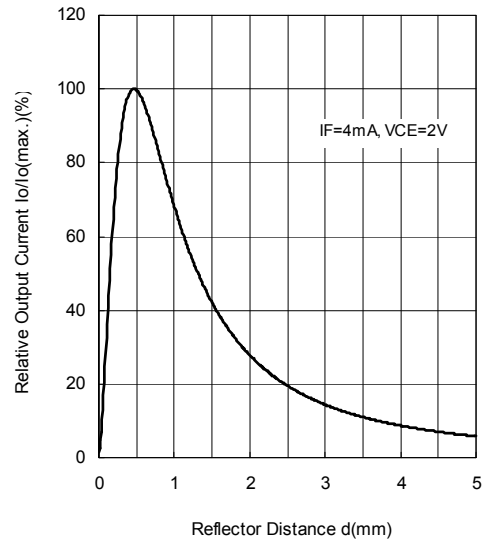

Directivity at Package direction X

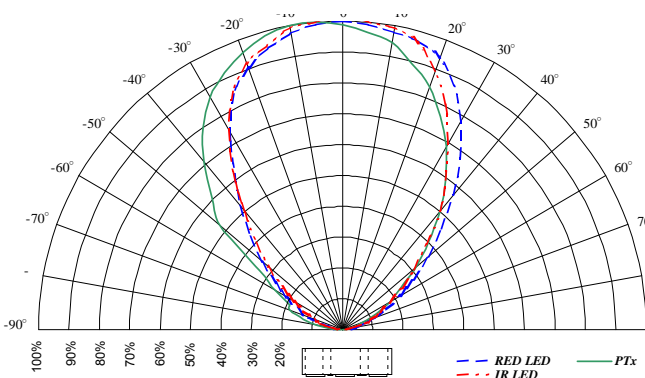

Directivity at Package direction Y

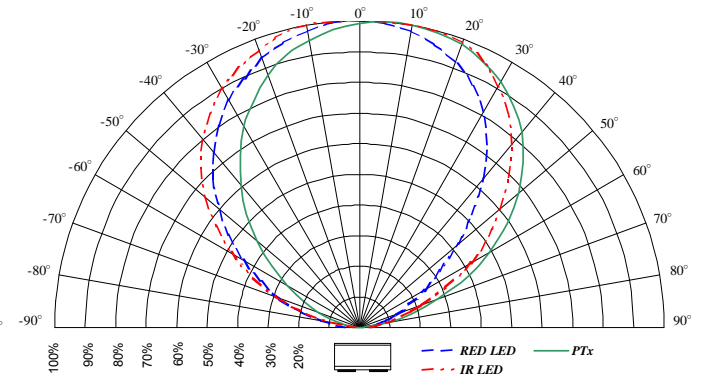

Spectral Response (Ta=25°C)
Emitter RED LED

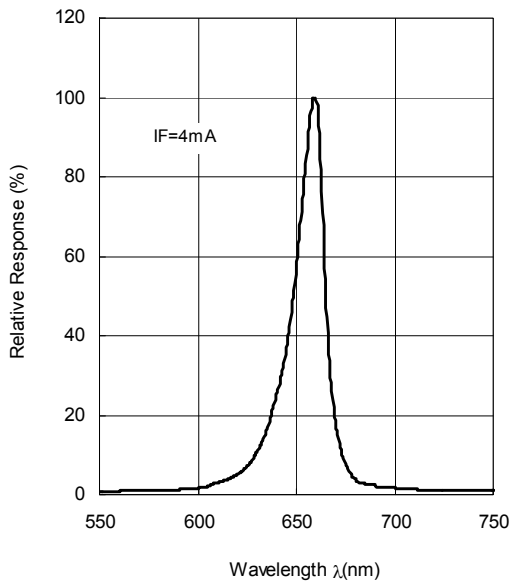

Spectral Response (Ta=25°C)
Emitter IR LED

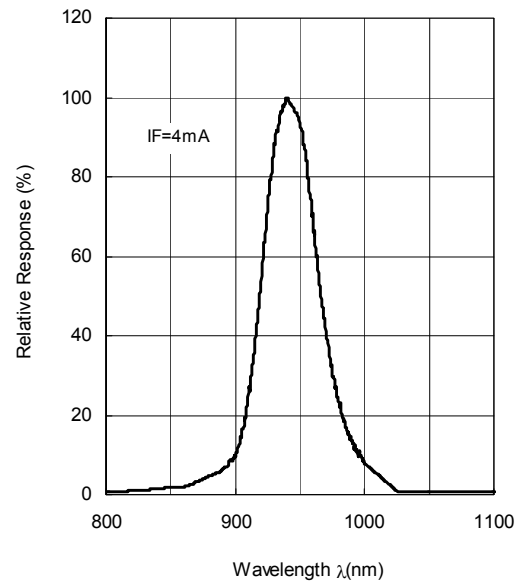

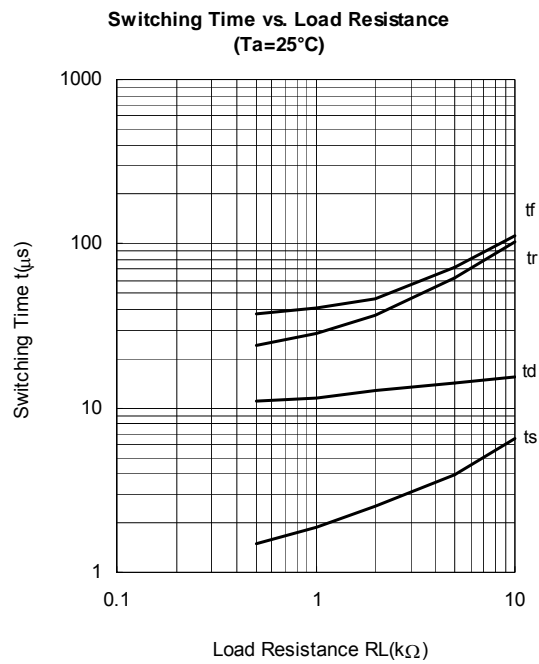

Remark: Please be aware that all data in the graph are only reference and are not any guarantee.

■ MOUNTING METHOD

NOTE

Mounting was evaluated with the following profiles in our company, so there was no problem.
However, confirm mounting by the condition of your company beforehand.

Mounting: Twice soldering is allowed.

■ INFRARED REFLOW SOLDERING METHOD

Recommended reflow soldering procedure

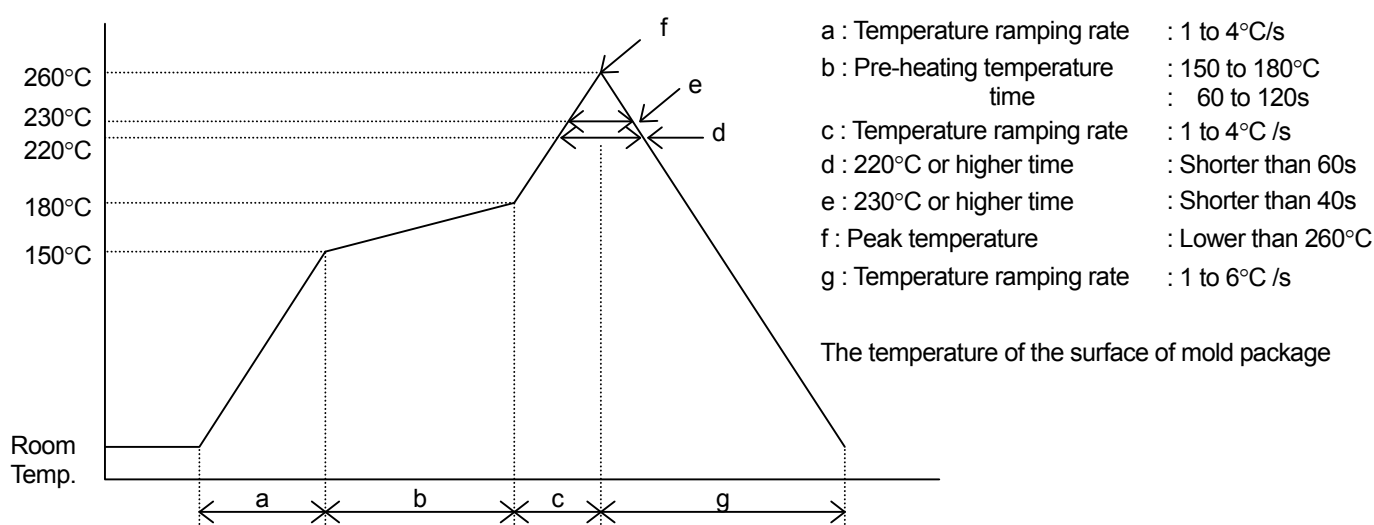

(NOTE1) Using reflow furnace with short wave infrared radiation heater such as halogen lamp

Regarding temperature profile, please refer to those fo reflow furnace.

In this case the resin surface temperature may become higher than lead terminals due to endothermic ally of black colored mold resin. Therefore, please avoid from direct exposure to mold resin.

(NOTE2) Other method

Such other methods of soldering as dipping the device into melted solder and vapor phase method (VPS) are not appropriate because the body of device will be heated rapidly. Therefore, these are not recommended to apply.

(NOTE3) The resin gets softened right after soldering, so, the following care has to be taken

Not to contact the lens surface to anything.

Not to dip the device into water or any solvents.

■ FLOE SOLDERING METHOD

Flow soldering is not possible.

■ IRON SOLDERING METHOD

Iron soldering is not possible.

■ CLEANING

Avoid washing the device after soldering by reflow method.

■ IC STORAGE CONDITIONS AND ITS DURATION

(1) Temperature and humidity ranges

Pack Sealing	Temperature:	5 to 40 [°C]
	Humidity:	40 to 80 [%]
Pack Opening	Temperature:	5 to 30 [°C]
	Humidity:	40 to 70 [%]

After opening the bag, solder products within 48h.

Avoid a dry environment below 40% because the products are easily damageable by the electrical discharge.

Store the products in the place where it does not create dew with the products due to a sudden change in temperature.

(2) When baking, place the reel vertically to avoid load to the side.

(3) Do not store the devices in corrosive-gas atmosphere.

(4) Do not store the devices in a dusty place.

(5) Do not expose the devices to direct rays of the sun.

(6) Do not allow external forces or loads to be applied to IC's.

(7) BE careful because affixed label on the reel might be peeled off when baking.

■ BAKING

In case of keeping expect above condition be sure to apply baking. (Heat-resistant tape)

Baking method: Ta=60°C, 48 to 72h, Three times baking is allowed

■ STORAGE DURATION

Within a year after delivering this device.

For the products stored longer than a year, confirm their terminals and solderability before they are used.

■ APPLICATION NOTES

(1) Attention in handling

Treat not to touch the lens surface.

Avoid dust and any other foreign materials on the lens surface such as point, bonding material, etc.

Never to apply reverse voltage (VEC) of more than 6V on the photo transistor when measuring the characteristics or adjusting the system. If applied, it causes to lower the sensitivity.

When mounting, special care has to be taken on the mounting position and tilting of the device because it is very important to place the device to the optimum position to the object.

PACKING SPECIFICATION

PACKING DIMENTIONS UNIT : mm

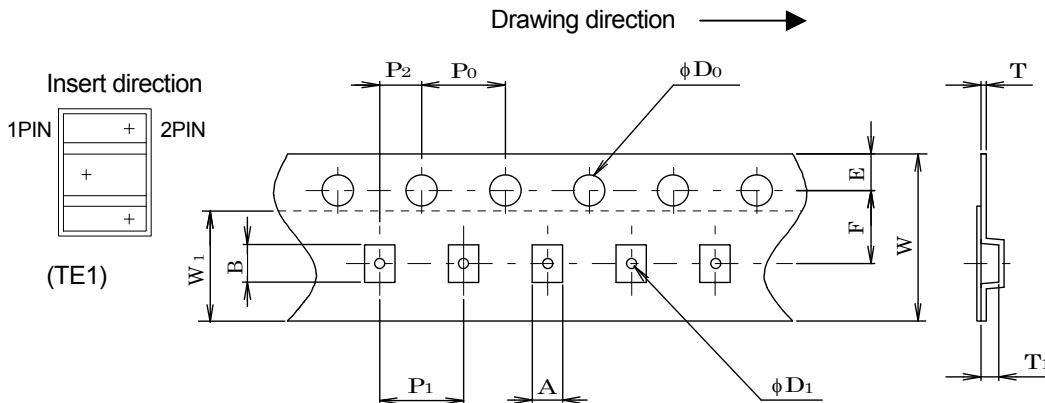

SYMBOL	DEMENSION	REMARKS
A	2.15±0.10	BOTTOM DIMENSION
B	2.85±0.10	BOTTOM DIMENSION
D0	1.5 ^{+0.10} ₋₀	
D1	1.5 ^{+0.10} ₋₀	
E	1.75±0.10	
F	3.50±0.05	
P0	4.00±0.10	
P1	4.00±0.10	
P2	2.00±0.05	
T0	0.25±0.05	
T1	1.05±0.10	
W0	8.00±0.10	
W1	5.40±0.10	THICKNESS0.1MAX

* Carrier tape material : Polycarbonate(antistatic)
Cover tape material : Polyester(antistatic)

Taping Strength

Pull up the cover tape from the carrier tape, and when the opening angle comes around 10 to 15 , and the peeling-off strength is to be within the power of 20 to 70g.

Packaging

- 1) The taped products are to be rolled up on the taping reel as on the drawing.
- 2) Rolling up specification
 - 2-1) Start rolling : Carrier tape open space more than 20 Pieces.
 - 2-2) End of rolling : Carrier tape open space more than 20 Pieces, and 2 round of reel space at the cover tape only.
- 3) Taping quantity : 2,000 Pieces
- 4) Seal off after putting each reels in a damp proof bag with silica gel.

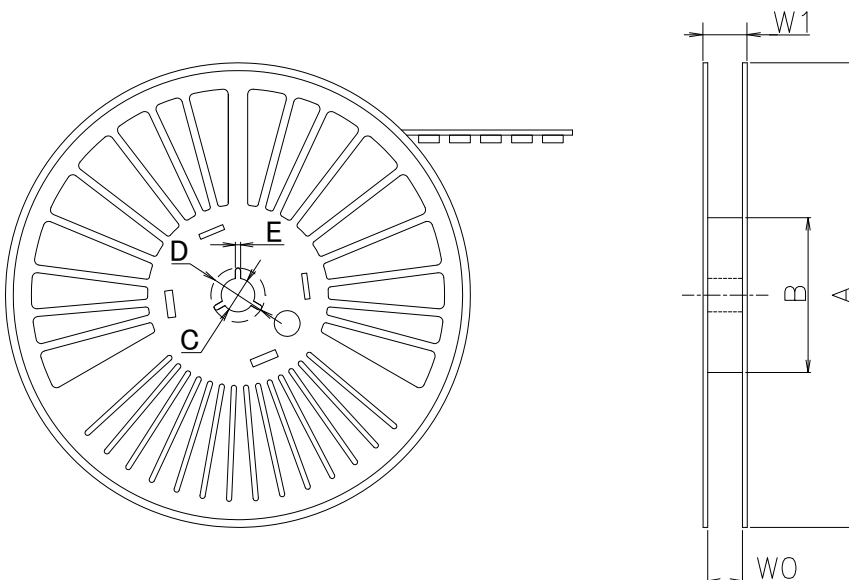

SYMBOL	DEMENSION
A	φ180.0±1.0
B	φ60.0±0.5
C	φ13.0±0.2
D	φ21.0±0.8
E	2.0±0.5
W0	9.5±0.5
W1	12.6±1.0

[CAUTION]

The specifications on this databook are only given for information , without any guarantee as regards either mistakes or omissions. The application circuits in this databook are described only to show representative usages of the product and not intended for the guarantee or permission of any right including the industrial rights.

Компания «Life Electronics» занимается поставками электронных компонентов импортного и отечественного производства от производителей и со складов крупных дистрибьюторов Европы, Америки и Азии.

С конца 2013 года компания активно расширяет линейку поставок компонентов по направлению коаксиальный кабель, кварцевые генераторы и конденсаторы (керамические, пленочные, электролитические), за счёт заключения дистрибьюторских договоров

Мы предлагаем:

- Конкуренспособные цены и скидки постоянным клиентам.
- Специальные условия для постоянных клиентов.
- Подбор аналогов.
- Поставку компонентов в любых объемах, удовлетворяющих вашим потребностям.
- Приемлемые сроки поставки, возможна ускоренная поставка.
- Доставку товара в любую точку России и стран СНГ.
- Комплексную поставку.
- Работу по проектам и поставку образцов.
- Формирование склада под заказчика.
- Сертификаты соответствия на поставляемую продукцию (по желанию клиента).
- Тестирование поставляемой продукции.
- Поставку компонентов, требующих военную и космическую приемку.
- Входной контроль качества.
- Наличие сертификата ISO.

В составе нашей компании организован Конструкторский отдел, призванный помогать разработчикам, и инженерам.

Конструкторский отдел помогает осуществить:

- Регистрацию проекта у производителя компонентов.
- Техническую поддержку проекта.
- Защиту от снятия компонента с производства.
- Оценку стоимости проекта по компонентам.
- Изготовление тестовой платы монтаж и пусконаладочные работы.



Тел: +7 (812) 336 43 04 (многоканальный)

Email: org@lifeelectronics.ru