

PLEASE CHECK WWW.MOLEX.COM FOR LATEST PART INFORMATION

Part Number: [0002081104](#)
Status: **Active**
Description: Claspcn™ Crimp Terminal Socket, Tin (Sn) Plated Brass Contact, 24-30 AWG, Bag

Documents:

[Drawing \(PDF\)](#) [RoHS Certificate of Compliance \(PDF\)](#)

Agency Certification

CSA LR19980
 UL E29179

General

Product Family Crimp Terminals
 Series [1881](#)
 Crimp Quality Equipment Yes
 Product Name Claspcn™

Physical

Gender Female
 Material - Metal Brass
 Material - Plating Mating Tin
 Material - Plating Termination Tin
 Packaging Type Bag
 Plating min: Mating (µin) 20
 Plating min: Mating (µm) 0.50
 Plating min: Termination (µin) 20
 Plating min: Termination (µm) 0.50
 Termination Interface: Style Crimp or Compression
 Wire Insulation Diameter 0.76-1.52mm (.030-.060")
 Wire Size AWG 24, 26, 28, 30
 Wire Size mm² N/A

Material Info

Old Part Number 188103L

Reference - Drawing Numbers

Sales Drawing SD-1881-*

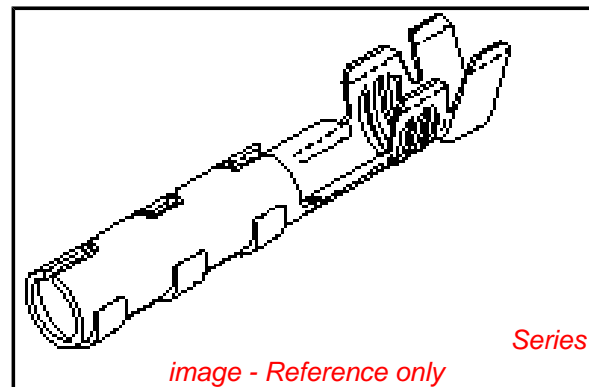

image - Reference only

EU RoHS

**ELV and RoHS
 Compliant**
**REACH SVHC
 Contains SVHC: No**
**Halogen-Free
 Status
 Not Reviewed**

China RoHS



**Need more information on product
 environmental compliance?**

Email productcompliance@molex.com
 For a multiple part number RoHS Certificate of
 Compliance, [click here](#)

Please visit the [Contact Us](#) section for any
 non-product compliance questions.

Search Parts in this Series

[1881Series](#)

Mates With

16-06-0005

Application Tooling | FAQ

*Tooling specifications and manuals are
 found by selecting the products below.
 Crimp Height Specifications are then
 contained in the Application Tooling
 Specification document.*

Global

Description	Product #
HAND CRIMP TOOL	0638117100

13 12 11 10 9 8 7 6 5 4 3 2 1

J I H G F E D C B A

1881-2*** TERMINAL SHOWN (16-24 AWG)
SEE SHEET 2 FOR 1881-3*** TERMINAL

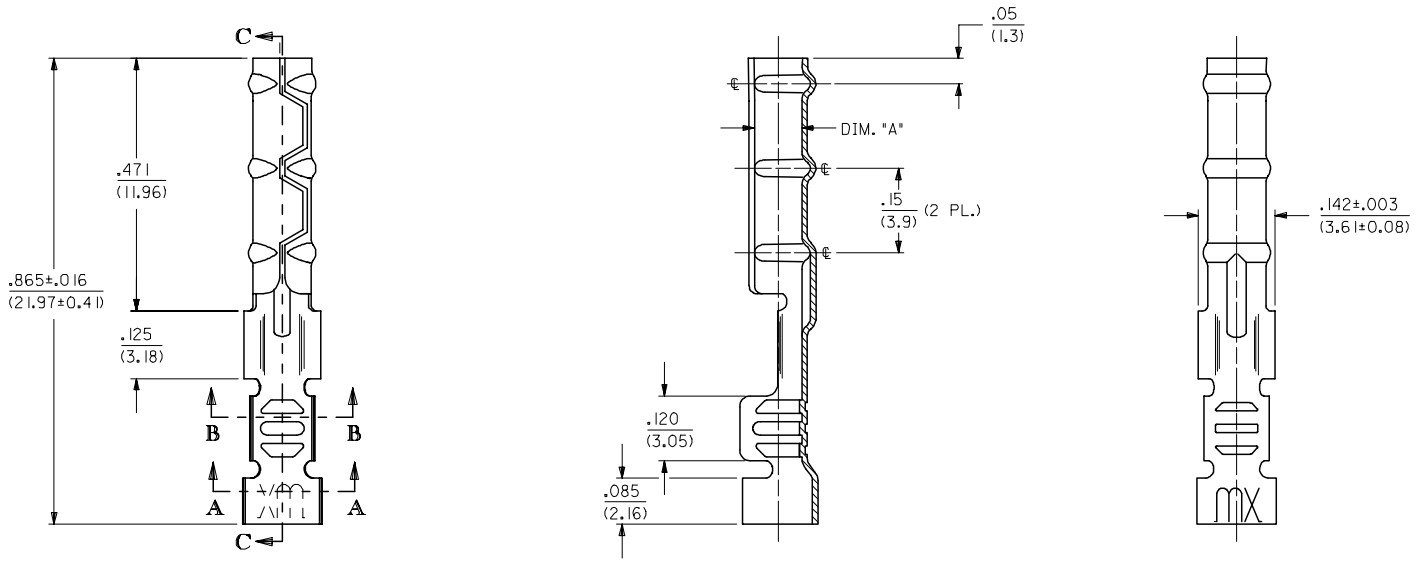

SECTION C-C

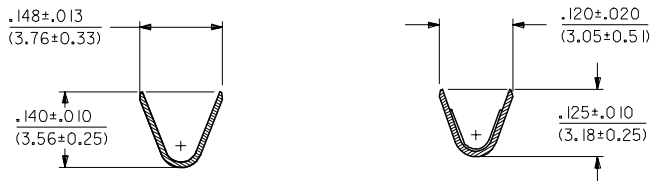

SECTION A-A

SECTION B-B

2	L1
1	L1
SHT/REV	

UPDATE TITLE BLOCK EC NO: UCP2006-0215 2005/08/05 DRAWN: JLONE 2005/08/10 CHKD: ADERR 2005/08/10 APPR: FSM TH 2005/08/10 REVISIONS L1	QUALITY SYMBOLS ▽=0 ▽=0	GENERAL TOLERANCES (UNLESS SPECIFIED) <table border="1"> <tr> <th></th> <th>mm</th> <th>INCH</th> </tr> <tr> <td>4 PLACES</td> <td>± .10</td> <td>± .004</td> </tr> <tr> <td>3 PLACES</td> <td>± .12</td> <td>± .005</td> </tr> <tr> <td>2 PLACES</td> <td>± .15</td> <td>± .006</td> </tr> <tr> <td>1 PLACE</td> <td>± .20</td> <td>± .008</td> </tr> </table> ANGULAR ±1/2°		mm	INCH	4 PLACES	± .10	± .004	3 PLACES	± .12	± .005	2 PLACES	± .15	± .006	1 PLACE	± .20	± .008	DIMENSION STYLE IN/MM DRAWN BY: JWC DATE: 3/11/91 CHECKED BY: RW DATE: 3/11/91 APPROVED BY: JWF DATE: 3/11/91 MATERIAL NO.	SCALE: 6:1 DESIGN UNITS: INCH THIRD ANGLE PROJECTION	TITLE: CRIMP TERMINAL SOCKET, CLASPCON MOLEX INCORPORATED DOCUMENT NO. SD-1881-* SHEET NO. 1 OF 2
		mm	INCH																	
	4 PLACES	± .10	± .004																	
	3 PLACES	± .12	± .005																	
2 PLACES	± .15	± .006																		
1 PLACE	± .20	± .008																		
DRAFT WHERE APPLICABLE MUST REMAIN WITHIN DIMENSIONS		SEE CHART	THIS DRAWING CONTAINS INFORMATION THAT IS PROPRIETARY TO MOLEX INCORPORATED AND SHOULD NOT BE USED WITHOUT WRITTEN PERMISSION																	

12 11 10 9 8 7 6 5 4 3 2 1

CHART			
PART NUMBER	ENG. NUMBER	DIMENSION "A" (DIA.)	
02-08-1102	1881-2L1A	.085/.090 (2.16/2.29)	
02-08-1101	1881-2C1A		
02-08-1106	1881-2L1B	.083/.088 (2.11/2.24)	OBSOLETE
02-08-1105	1881-2C1B		OBSOLETE
02-08-1104	1881-3L1A	.085/.090 (2.16/2.29)	
02-08-1103	1881-3C1A		
02-08-1107	1881-4C1A	.085/.090 (2.16/2.29)	OBSOLETE
02-08-1108	1881-4L1A		OBSOLETE

1881-3*** TERMINAL SHOWN (24-30 AWG)
SEE SHEET 1 FOR 1881-2*** TERMINAL

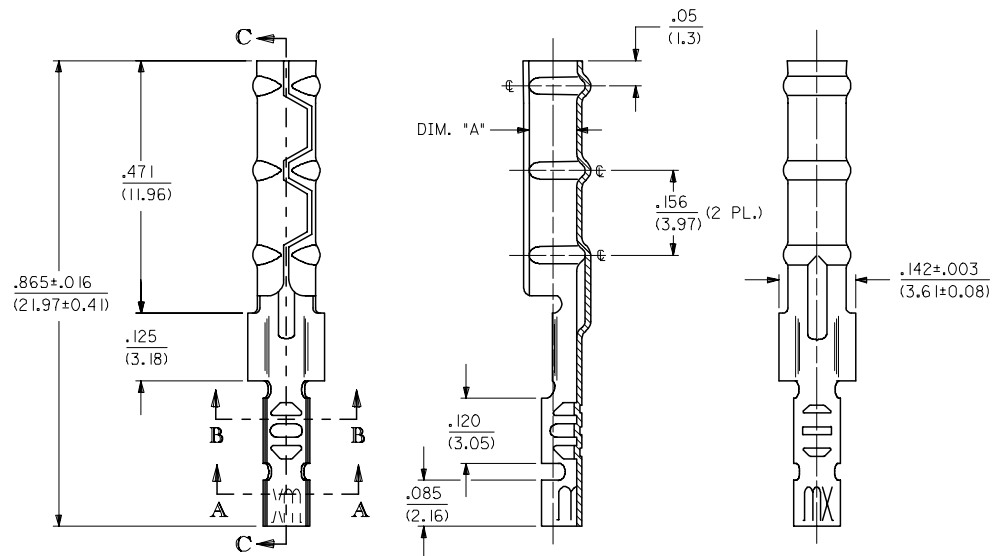

SECTION C-C

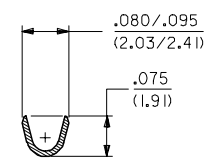

SECTION A-A

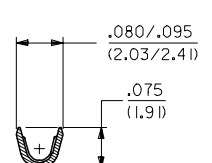

SECTION B-B

LEGEND

1881-***
 CRIMP STYLE
 2 = 16-24 AWG
 3 = 24-30 AWG
 4 = 22 AWG
 BARREL I.D.
 A = .085/.090 BARREL I.D.
 FORM
 L = LOOSE
 C = CHAIN
 FINISH
 (*P* PRECEDING FINISH NO. DESIGNATES PREPLATED MATERIAL)
 1 = P901 - HOT TIN DIP: .000020/(0.0005) MIN.

- NOTES:
- MATERIAL: CARTRIDGE BRASS
 - FINISH: SEE LEGEND
 - PRODUCT SPECIFICATION: N/A
 - PACKAGING SPECIFICATION: N/A
 - 1881 "CLASPCON" SERIES TERMINAL WITH THE STANDARD BARREL I.D. IS INTENDED FOR MATING TO .093/(2.36) DIA. P.C. BOARD PINS.
 - INITIAL EXTRACTION FORCE TO BE 4.0±1.5 LBS. FROM AN .093/.092 / (2.36/2.34) DIA. PIN AND 2 LBS. MIN. AFTER THE 10TH EXTRACTION ON STANDARD BARREL I.D.

OBSOLETE 02-08-1102 EC NO: UCP2006-0215 DRAWN: JLONE 2005/08/05 CHKD: ADERR 2005/08/10 APPR: FSM TH 2005/08/10 L1	REVISION DESCRIPTION	QUALITY SYMBOLS =0 =0	GENERAL TOLERANCES (UNLESS SPECIFIED)	DIMENSION STYLE IN/MM	SCALE 6:1	DESIGN UNITS INCH	THIRD ANGLE PROJECTION	
			mm INCH	DRAWN BY JWC	DATE 3/11/91	TITLE CRIMP TERMINAL SOCKET, CLASPCON		
			4 PLACES ± --- ± --- 3 PLACES ± --- ± .010 2 PLACES ± 0.25 ± .014 1 PLACE ± 0.36 ± --- ANGULAR ±1/2°	CHECKED BY RW	DATE 3/11/91	MATERIAL NO. SD-1881-*		
			DRAFT WHERE APPLICABLE MUST REMAIN WITHIN DIMENSIONS	APPROVED BY JWF	DATE 3/11/91	DOCUMENT NO. SD-1881-*		
				SIZE C	THIS DRAWING CONTAINS INFORMATION THAT IS PROPRIETARY TO MOLEX INCORPORATED AND SHOULD NOT BE USED WITHOUT WRITTEN PERMISSION		SHEET NO. 2 OF 2	

Компания «Life Electronics» занимается поставками электронных компонентов импортного и отечественного производства от производителей и со складов крупных дистрибьюторов Европы, Америки и Азии.

С конца 2013 года компания активно расширяет линейку поставок компонентов по направлению коаксиальный кабель, кварцевые генераторы и конденсаторы (керамические, пленочные, электролитические), за счёт заключения дистрибьюторских договоров

Мы предлагаем:

- Конкурентоспособные цены и скидки постоянным клиентам.
- Специальные условия для постоянных клиентов.
- Подбор аналогов.
- Поставку компонентов в любых объемах, удовлетворяющих вашим потребностям.
- Приемлемые сроки поставки, возможна ускоренная поставка.
- Доставку товара в любую точку России и стран СНГ.
- Комплексную поставку.
- Работу по проектам и поставку образцов.
- Формирование склада под заказчика.
- Сертификаты соответствия на поставляемую продукцию (по желанию клиента).
- Тестирование поставляемой продукции.
- Поставку компонентов, требующих военную и космическую приемку.
- Входной контроль качества.
- Наличие сертификата ISO.

В составе нашей компании организован Конструкторский отдел, призванный помогать разработчикам, и инженерам.

Конструкторский отдел помогает осуществить:

- Регистрацию проекта у производителя компонентов.
- Техническую поддержку проекта.
- Защиту от снятия компонента с производства.
- Оценку стоимости проекта по компонентам.
- Изготовление тестовой платы монтаж и пусконаладочные работы.



Тел: +7 (812) 336 43 04 (многоканальный)
Email: org@lifeelectronics.ru