

GW INDUSTRIES

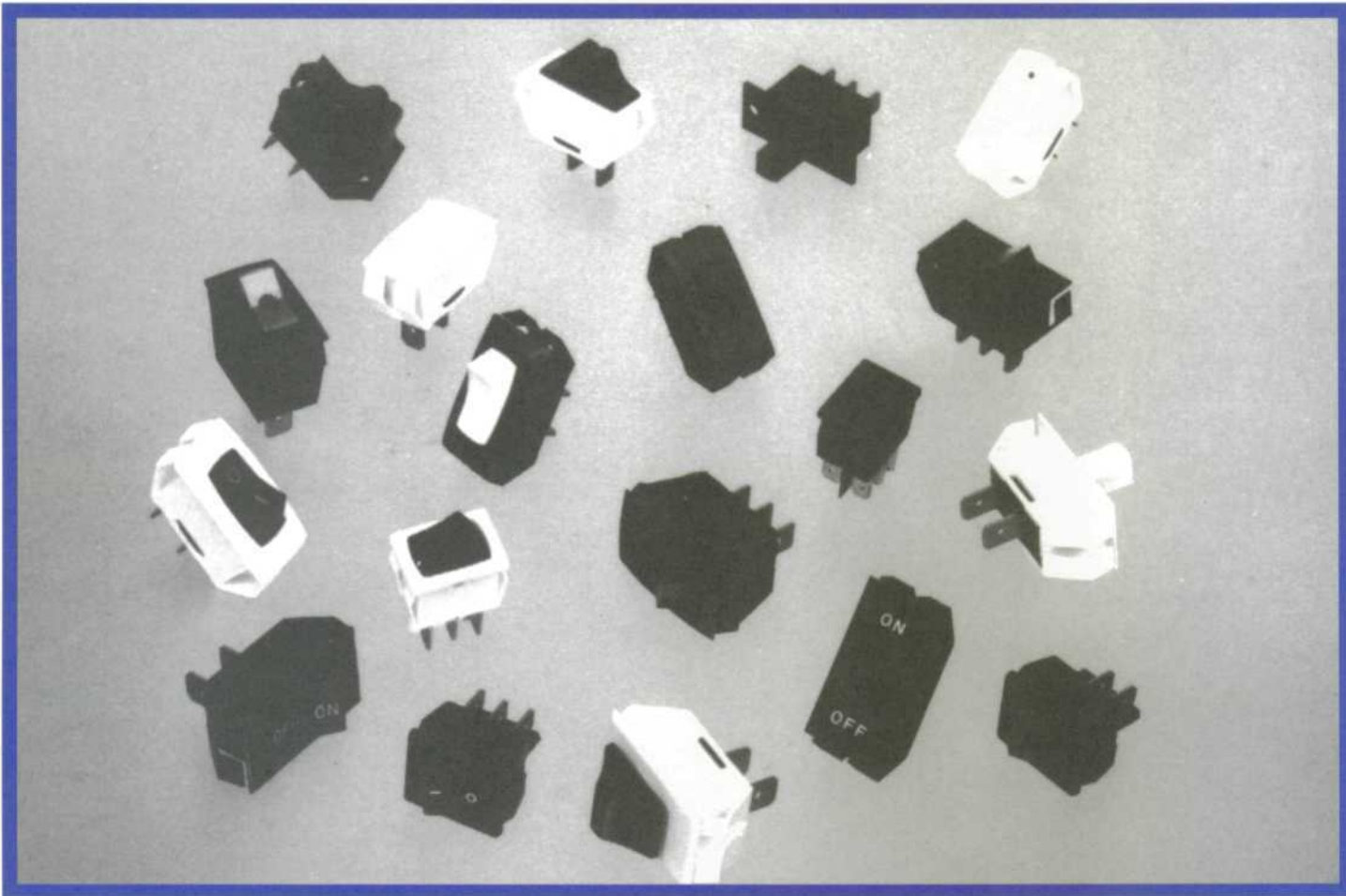

ROCKER AND POWER SLIDE SWITCHES



CW INDUSTRIES. . . **Reliability by Design**

For more than eighty years, CW has provided innovative products through automated manufacturing and quality assurance techniques unmatched in any segment of the electronics industry. Total integration of connector and switch manufacturing, coupled with advanced computer assisted design and engineering, enable CW to provide an unprecedented degree of design and production flexibility. All product is tested in our fully certified test labs for all chemical, mechanical and electrical parameters, including UL, CSA, VDE, military or individual company standards. This assures the very highest levels of quality and reliability without sacrificing manufacturing efficiencies.



CW INDUSTRIES. . . **Imagination by Design**

CW's highly skilled technical support teams are ready to help you explore imaginative new ways to solve even the most difficult design problems. From a simple switch mounting to a highly complex circuit board interface, the solution may be just a phone call away.

CW INDUSTRIES. . . **Service by Design**



All CW products are available through a nationwide network of stocking distributors and value-added assembly centers. They have a comprehensive inventory of switches as well as flat cable and connectors for delivery of either individual components or 100% pre-tested assemblies made to your specifications... from prototype to production quantities... faster than you ever thought possible.

Contents - Rocker and Power Slide Switches

4000 SERIES MINI-ROCKER SWITCHES

PAGE	SWITCH TYPE	CIRCUITRY	ELECTRICAL RATINGS	
2-3	<i>Maintained Action</i> GRS-4011 GRS-4012 GRS-4021 GRS-4022	SPST SPDT DPST DPDT	8A-16A versions available. See page 2 for details.	
4	<i>Momentary</i> GRS-4011B GRS-4011C GRS-4012A GRS-4021B GRS-4021C GRS-4022A	SPST SPST SPDT DPST DPST DPDT	Momentary/Normally Open Momentary/Normally Closed Momentary Momentary/Normally Open Momentary/Normally Closed Momentary	8A-16A versions available. See page 4 for details.
5	<i>Center-Off</i> GRS-4013A GRS-4013B GRS-4013C GRS-4023A GRS-4023B GRS-4023C	SPDT-CO SPDT-CO SPDT-CO DPDT-CO DPDT-CO DPDT-CO	on - OFF - on mom - OFF - on mom - OFF - mom on - OFF - on mom - OFF - on mom - OFF - mom	8A-13A versions available. See page 5 for details.
6-7	<i>Illuminated</i> GRL-4011 GRL-4012 GRL-4021 GRL-4022	SPST SPDT DPST DPDT		8A-16A versions available. See page 7 for details.

2000 SERIES ROCKER AND POWER SLIDE SWITCHES

PAGE	SWITCH TYPE	CIRCUITRY	ELECTRICAL RATINGS	
8	<i>Maintained Action</i> GRS-2011 GRS-2012	SPST SPDT	8A-16A versions available. See page 8 for details.	
 9	<i>Momentary</i> GRS-2011B GRS-2011C GRS-2012A	SPST SPST SPST	Momentary/Normally Open Momentary/Normally Closed Momentary	8A-13A versions available. See page 8 for details.
 10	<i>StyleLine™</i> GRS-2011-24/25 GRS-2012-24/25 GRS-2013A-24/25	SPST SPDT SPDT-CO	on - OFF - on	16A version available. See page 10 for details.
11	<i>Center-Off</i> GRS-2013A GRS-2013B GRS-2013C	SPDT-CO SPDT-CO SPDT-CO	on - OFF - on mom - OFF - on mom - OFF - mom	8A-16A versions available. See page 11 for details.
12	<i>Illuminated</i> GRL-2011	SPST		8A-16A versions available. See page 12 for details.
13	<i>Double Pole</i> GR-2021 GR-2022 GR-2021B GR-2021C GR-2022A GR-2023A GR-2023B GR-2023C	DPST DPDT DPST DPST DPDT DPDT-CO DPDT-CO DPDT-CO	Momentary/Normally Open Momentary/Normally Closed Momentary on - OFF - on mom - OFF - on mom - OFF - mom	8A-16A versions available. See page 13 for details.
14-15	<i>Slide Switches</i> GF-1623 G-2011 G-2012 GS-2011 GS-2012	SPST SPST SPDT SPST SPDT	Chassis Mount Panel Mount Panel Mount Chassis Mount Chassis Mount	8A-16A versions available. See page 14-15 for details.

4000 Series: Maintained Action Mini-Rocker Switches

CW Mini-Rocker Switches are available in single or double pole and are capable of switching currents normally associated with units much larger in size.

Typical applications include:

Motor-driven devices, instruments, household appliances, automobile accessories, recreational vehicles, and power tools.



GRS-4022 Switch

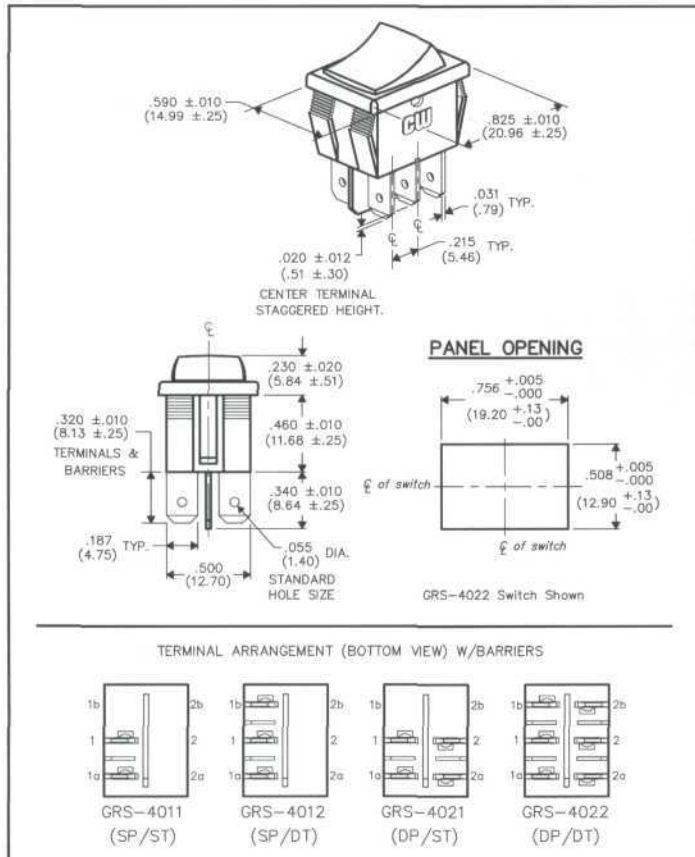

MATERIALS⁺

Rocker Knob: Nylon 94V-2

Housing: Nylon 94V-2

Terminal & Moving Contact:

Copper Alloy, and/or Copper Alloy Silver Plated.

Springs: Music Wire

Plunger: Brass

MOUNTING

Self locks without hardware when popped into a .756" (19.20 mm) x .508" (12.90 mm) panel cutout. Acceptable panel thickness range is from .050" (1.27 mm) to .150" (3.81 mm).

CAUTION: Burr direction must be away from the direction of insertion.

TYPES AVAILABLE

TYPE	CIRCUIT	ELECTRICAL RATING [†]	LISTING AGENCY ^{††}
GRS-4011-8,-13,-16	SPST	-8: 8 A @ 125 VAC / 4A @ 250 VAC 3 A @ 277 VAC	UL/CSA
GRS-4012-8,-13,-16	SPDT	-13: 13 A @ 125 VAC / 10 A @ 250 VAC	UL/CSA
GRS-4021-8,-13,16	DPST	1/2 HP 125 - 250 VAC 5 A 14V (T)	
GRS-4022-8,-13,-16	DPDT	-16: 16 A @ 125 - 250 VAC 3/4 HP 125 - 250 VAC 10 A 14 V (T) 3 A 125 V (L) 10 (4) A 250-μ (VDE)*	UL/CSA/VDE

*Switches marked μ are acceptable for use as power switches provided there is a plug disconnect or a switch with open contact gaps of 3 mm minimum.

†All ratings are on a load per pole, opposite polarity basis. Additional ratings may be available, consult factory.

††Due to ongoing advancements, additional agency certifications may be available, consult factory.

OPTIONAL FEATURES

COLORS:

Standard switch includes black housing and rocker knob. Knobs and housings can be molded in many colors. Contact us if you have unusual color needs... such as matching mating parts or satisfying unique requirements of your stylists. Our technicians can usually match any color required. Check factory for more information.

SPECIAL MARKINGS:

Printing on the knob or housing indicating message appropriate to the application ("ON - OFF", "HI - LO", "I/O" etc.) is available. Check factory.

TERMINATION:

Standard is solderless, .187" (4.75 mm) x .032" (.81 mm). Other options include: .110" (2.79 mm) x .032" (.81 mm) solderless (G-20-173); .187" (4.75 mm) x .020" (.51 mm) solderless (G-20-180); .110" (2.79 mm) wide with .048" (1.22 mm) x .237" (6.02 mm) slot for easier hand soldering (G-20-179).

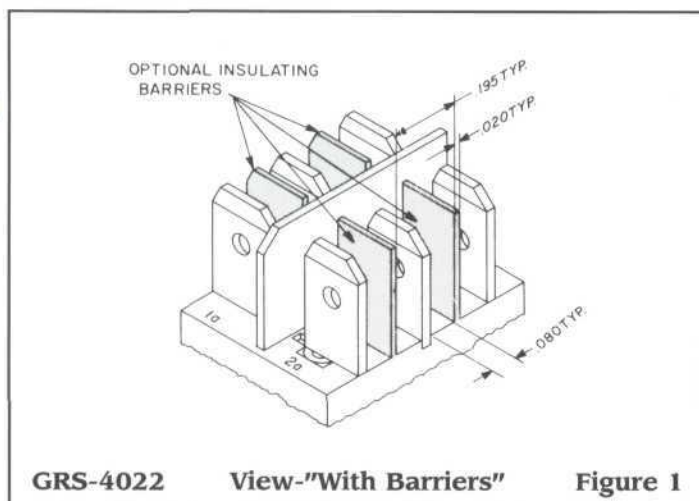

INSULATING BARRIERS:

Standard on all double pole switches is a molded insulating barrier between rows of terminals on adjacent poles. **Optional** on single pole and double pole switches are insulating barriers between terminals of the same pole. Insulating barriers can permit the use of less costly uninsulated solderless connectors. See Figure 1. To specify barriers between terminals of same pole on both single and double pole versions request switch "with barriers."

FEATURES

- Crisp detent action
- Small switch – high current switching
- Active switch elements enclosed and protected
- Optional insulation barriers between terminals on same pole
- Easy to terminate with solderless connectors or by hand soldering
- Brass plunger withstands high temperature
- Insulating barriers between terminals of opposite polarity
- Self cleaning contacts
- Color options

GRS-4022 Switch

OPERATING STANDARDS⁺

Endurance:

- 100,000 cycles, no load, minimum
- 25,000 cycles at rated load minimum up to 16 A @ 125 Vac
- 10,000 cycles at rated load minimum 16 A @ 250 Vac

Contact Resistance:

- Less than .01 Ω at 10 mA (Initial)

Operating Temperature:

- From 65°C - 125°C maximum

High Voltage Dielectric Withstanding Voltage:

- 2,500 V, 60 Hz for 1 minute between mounting surface and circuit connections

Humidity:

- Insulation resistance > 10³ M Ω after 100 hours at 95% R.H. and 50°C followed by 1 hour dry at ambient room conditions

HOW TO ORDER

Step 1: Select part number for your circuit needs and maximum current requirements.

Step 2: Standard switch color is all black. Specify optional knob or housing colors and any special markings required.

Step 3: Standard terminal is solderless .187" (4.75 mm) x .032" (.81 mm) and needs no further identification. Specify optional terminal if needed.

Step 4: Insulating barrier between rows of terminals on adjacent poles is standard. Specify "with barriers" for barriers between terminals of the same pole.

⁺Operating Standards and Materials described herein are general specifications that vary depending on the switch construction specified and end application. Consult factory for specifications for specific models. Specifications subject to change without notice.

4000 Series: Momentary Mini-Rocker Switches

For the user with a spring return application, CW offers the Momentary Mini-Rocker Switches. Available circuitries include SPST, SPDT, DPST, and DPDT. For additional design flexibility the single throw versions are available in normally open or normally closed versions. Materials used, mounting, termination, insulation barrier options and operating standards are the same as described for CW 4000 Series Mini-Rockers featured on pages 2 and 3.

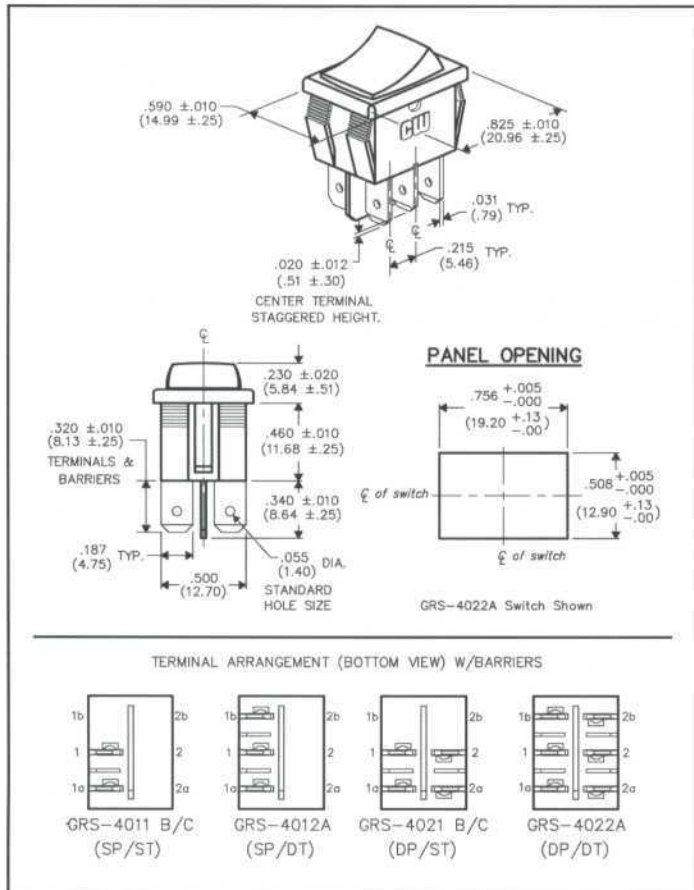

FEATURES

- Small switch – high current switching.
- Heavy duty return spring provides for consistent operating force.
- Color options
- Brass plunger withstands high temperature
- Active switch elements enclosed and protected.
- Easy to terminate with solderless connectors or by hand soldering.
- Insulating barriers between terminals of opposite polarity. Insulating barriers between terminals on same pole are optional.
- Self cleaning contacts
- Single throw versions available in normally open or normally closed construction.

GRS-4022A Switch

HOW TO ORDER

Step 1: Select part number for your circuit needs and maximum current requirements.

Step 2: Standard switch is all black. Specify optional knob or housing colors and any special markings required.

Step 3: Standard terminal is solderless, $.187$ " (4.75 mm) x $.032$ " (.81 mm), and needs no further identification. Specify optional terminals: G-20-173, $.110$ " (2.79 mm) x $.032$ " (.81 mm) solderless; G-20-180, $.187$ " (4.75 mm) x $.020$ " (.51 mm) solderless; G-20-179, $.110$ " (2.79 mm) with $.048$ " (1.22 mm) x $.237$ " (6.02 mm) slot for hand wiring.

Step 4: Insulating barrier between rows of terminals on adjacent poles is standard. Specify "with barriers" for barriers between terminals of the same pole.

TYPES AVAILABLE

TYPE	CIRCUIT	ELECTRICAL RATING [†]	LISTING AGENCY ^{††}
GRS-4011B-8, -13, -16	SPST(Normally Open)	-8: 8 A @ 125 VAC / 4A @ 250 VAC 3 A @ 277 VAC	UL/CSA
GRS-4011C-8, -13, -16	SPST(Normally Closed)	-13: 13 A @ 125 VAC / 10 A @ 250 VAC	UL/CSA
GRS-4012A-8, -13, 16	SPDT	1/2 HP 125 - 250 VAC 5 A @ 14V (T)	
GRS-4021B-8, -13, -16	DPST (Normally Open)	-16: 16 A @ 125 - 250 VAC	UL/CSA/VDE
GRS-4021C-8, -13, -16	DPST (Normally Closed)	3/4 HP 125 - 250 VAC 10 A @ 14 V (T)	
GRS-4022A-8, -13, -16	DPDT	3 A @ 125 V (L) 10 (4) A 250-μ (VDE)*	

*Switches marked μ are acceptable for use as power switches provided there is a plug disconnect or a switch with open contact gaps of 3 mm minimum.

[†]All ratings are on a load per pole, opposite polarity basis. Additional ratings may be available, consult factory.

^{††}Due to ongoing advancements, additional agency certifications may be available, consult factory.

4000 Series: Center-Off Mini-Rocker Switches

CW's Center-Off Mini-Rocker Switches are available in single pole or double pole construction... all in the same small package. Further, you may choose from a crisp detent action from both ends to center, momentary one end to center, or momentary both ends to center. Materials used, mounting, insulation barrier options and operating standards are the same as described for CW 4000 Series Mini-Rockers, featured on pages 2 and 3.

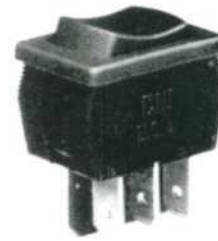

GRS-4013A Switch

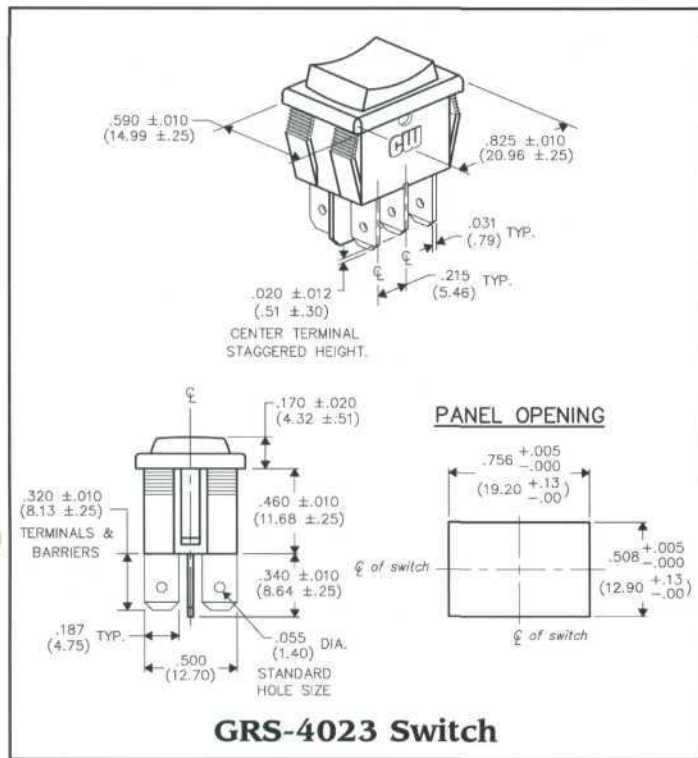

HOW TO ORDER

Step 1: Select part number that provides the combination of detent or momentary actuation and maximum current rating.

Step 2: Standard switch is all black. Specify optional knob or housing colors and any special markings required.

Step 3: Standard terminal is solderless, .187" (4.75 mm) x .032" (.81 mm). Specify optional terminals: G-20-188, .110" (2.79 mm) x .032" (.81 mm) solderless; G-20-189, .187" (4.75 mm) x .020" (.51 mm) solderless; G-20-186, .110" (2.79 mm) wide with .048" (1.22 mm) x .237" (6.02 mm) slot for hand wiring.

Step 4: Insulating barrier between rows of terminals on adjacent poles is standard. Specify "with barriers" for barriers between terminals of the same pole.

TYPES AVAILABLE

TYPE	CIRCUIT	ELECTRICAL RATING†	LISTING AGENCY††
GRS-4013A-8, -13	SPDT-CO (on-OFF-on)	-8: 8 A @ 125 VAC / 4A @ 250 VAC 3 A @ 277 VAC	UL/CSA
GRS-4013B-8, -13	SPDT-CO (mom-OFF-on)	-13: 13 A @ 125 VAC / 10 A @ 250 VAC 1/2 HP 125 - 250 VAC 5 A 14V (T)	UL/CSA/VDE
GRS-4013C-8, -13	SPDT-CO (mom-OFF-mom)		
GRS-4023A-8, -13	DPDT-CO (on-OFF-on)	10 (4) A 250-μ (VDE)*	
GRS-4023B-8, -13	DPDT-CO (mom-OFF-on)		
GRS-4023C-8, -13	DPDT-CO (mom-OFF-mom)		

*Switches marked μ are acceptable for use as power switches provided there is a plug disconnect or a switch with open contact gaps of 3 mm minimum.

†All ratings are on a load per pole, opposite polarity basis.

††Due to ongoing advancements, additional agency certifications may be available, consult factory.

NOTE: Momentary=mom

4000 Series: Illuminated Mini-Rocker Switches

CW's Illuminated Mini-Rocker Switches offer a variety of circuit and lighting options... with the current capacity normally associated with much larger switches. Select the circuitry that best satisfies your requirement either SPST, SPDT, DPST, or DPDT.

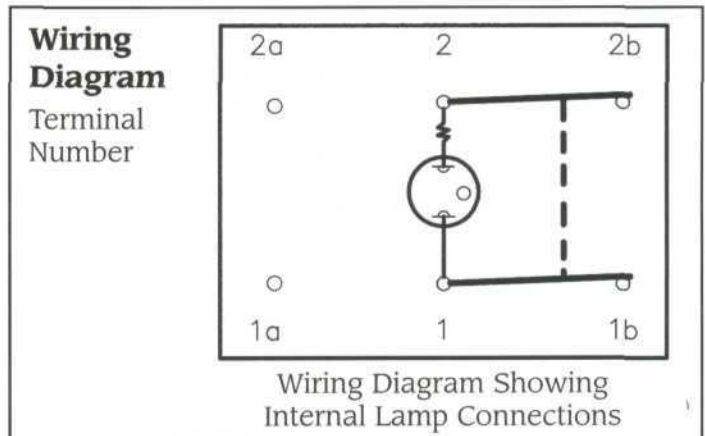
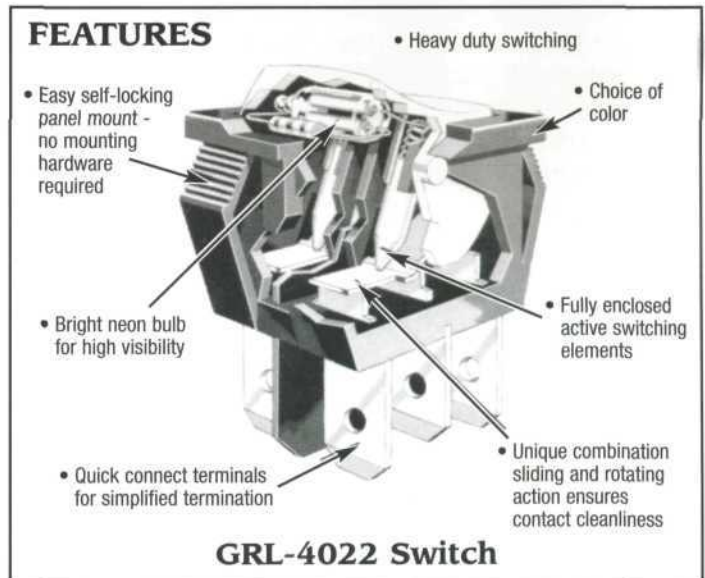
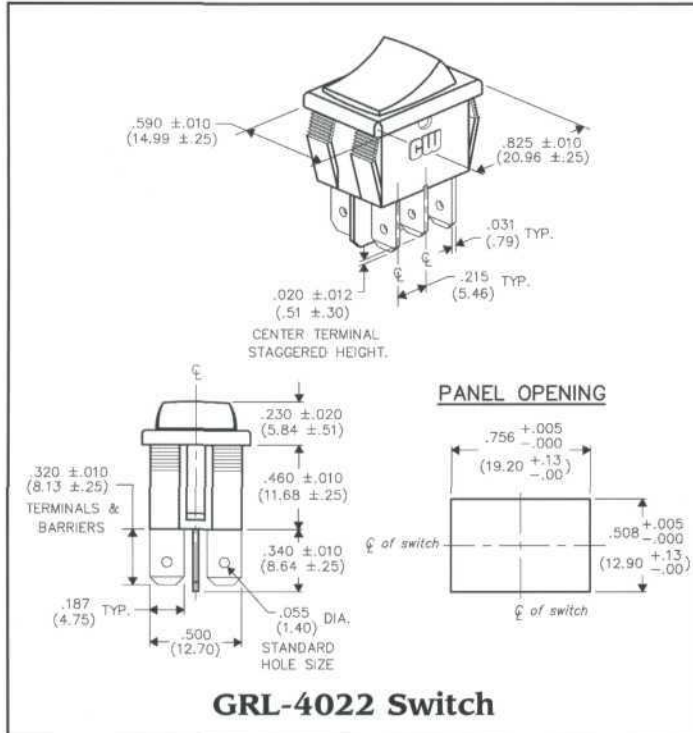

OPERATING STANDARDS⁺

Endurance:

- 100,000 cycles, no load minimum
- 25,000 cycles at rated load minimum up to 16 A @ 125 VAC
- 10,000 cycles at rated load minimum
- 16 A @ 250 VAC

Contact Resistance:

Less than .01 Ω at 10 mA (Initial)

Operating Temperature:

From 65°C - 125°C maximum

High Voltage Dielectric Withstanding Voltage:

2,500 V, 60 Hz for 1 minute between mounting surface and circuit connections

Humidity:

Insulation resistance > 10³ M Ω after 100 hours at 95% R.H. and 50°C followed by 1 hour dry at ambient room conditions

⁺Operating Standards and Materials described herein are general specifications that vary depending on the switch construction specified and end application. Consult factory for specifications for specific models. Specifications subject to change without notice.

MATERIALS⁺

Rocker Knob: Transparent polycarbonate (standard) or translucent nylon 6/6 (optional)

Rocker Lamp: High intensity neon lamp type NE-38 with 1/8 watt 47k ohm resistor, 10,000 hour life for 125 volt applications (standard)

Housing: Nylon 94V-2

Terminal & Moving Contact: Copper alloy, and/or copper alloy silver plated

Spring: Music wire

Plunger: Brass

MOUNTING

Self locks without hardware when popped into a .756" (19.20 mm) x .508" (12.90 mm) panel cutout. Acceptable panel thickness range is from .050" (1.27 mm) to .150" (3.81 mm).

CAUTION: Burr direction must be away from the direction of insertion.

TYPES AVAILABLE

TYPE	CIRCUIT	ELECTRICAL RATING [†]	LISTING AGENCY ^{††}
GRL-4011-8,-13,-16	SPST	-8: 8 A @ 125 VAC / 4A @ 250 VAC 3 A @ 277 VAC	UL/CSA
GRL-4012-8,-13,-16	SPDT	-13: 13 A @ 125 VAC / 10 A @ 250 VAC 1/2 HP 125 - 250 VAC 5 A @ 14V (T)	UL/CSA
GRL-4021-8,-13,-16	DPST		
GRL-4022-8,-13,-16	DPDT	-16: 16 A @ 125 - 250 VAC 3/4 HP 125 - 250 VAC 10 A @ 14 V (T) 3 A @ 125 V (L)	UL/CSA

[†]All ratings are on a load per pole, opposite polarity basis. Additional ratings may be available, consult factory.

^{††}Due to ongoing advancements, additional agency certifications may be available, consult factory.

OPTIONAL FEATURES

LAMP TYPES:

Standard is neon lamp type NE-38, for 125 volt applications.

Optional are neon lamps for 250 volt applications and incandescent lamps for 14 volt applications.

INSULATING BARRIERS:

Standard on all double pole switches is a molded insulating barrier between rows of terminals on adjacent poles. **Optional** on single pole and double pole switches are insulating barriers between terminals of the same pole. Insulating barriers can permit the use of less costly uninsulated solderless connectors. See Figure 1. To specify barriers between terminals of same pole on both single and double pole versions request switch "with barriers."

COLORS:

Our standard switch includes a black housing and a red transparent rocker knob. For design flexibility the switch housing can be molded in many popular colors. Also, translucent or transparent rocker knobs are available in a variety of colors. Contact the factory for details.

TERMINATION:

Standard is solderless, .187" (4.75 mm) x .032" (.81 mm). Other options include: .110" (2.79 mm) x .032" (.81 mm) solderless; (G-20-173); .187" (4.75 mm) x .020" (.51 mm) solderless; (G-20180); .110" (2.79 mm) wide with .048" (1.22 mm) x .237" (6.02 mm) slot for easier hand soldering (G-20-179).

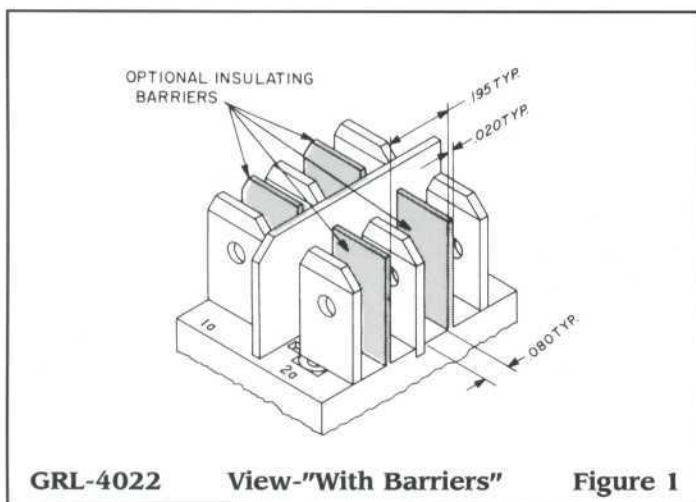

HOW TO ORDER

Step 1: Select part number that satisfies your maximum current needs.

Step 2: No added identification is required for standard 125V high light output neon lamp. Specify optional lamp if required.

Step 3: Insulation barriers between rows of terminals of adjacent poles is standard. Specify "with barriers" for barriers between terminals of the same pole.

Step 4: Standard switch has black housing and transparent red rocker knob. For special colors or knob materials, contact factory.

Step 5: Standard switch has .187" (4.75 mm) x .032" (.81 mm) solderless terminal. Specify optional terminal if required.



GRS-2012 Switch

CW Type GRS-2011 - SPST and GRS-2012 - SPDT Maintained Action Rocker Switches and GRS-2011 (B/C) Momentary Action Rocker Switches are designed to solve the switching problems of the user and styled to satisfy the designer... easy to mount, easy to terminate, and easy to actuate. Position may be identified by imprinting or hot stamping of rocker knob or housing in a legend of your choice. Other options include choice of electrical ratings, terminals, insulating barriers between terminals, and colors.

OPERATING STANDARDS⁺

Endurance:

- 100,000 cycles, no load minimum
- 25,000 cycles at rated load minimum

Contact Resistance:

Less than .01 Ω at 10 mA

Operating Temperature:

From 65°C - 125°C maximum

High Voltage Dielectric Withstanding Voltage:

2,500 V, 60 Hz for 1 minute between mounting surface and circuit connections (min.)

Relative Humidity:

Insulation resistance > 10³ M Ω after 100 hours at 95% R.H. and 50°C followed by 1 hour dry at ambient room conditions

FEATURES

- Easy self-locking panel mount - no mounting hardware required
- Fully enclosed active switching elements
- Light, yet positive detent action - virtually tease-proof
- Heavy duty switching
- Choice of color and markings
- Unique combination sliding and rotating action ensures contact cleanliness

GRS-2012 Switch

MATERIALS⁺

Rocker Knob: Nylon 94V-2

Housing: Nylon, 94V-2

Terminal & Moving Contact: Copper and/or copper alloy silver plated

MOUNTING

No hardware or tools needed; self locks into one of three available panel openings pictured on page 9. Acceptable panel thickness range from .025" (.64 mm) to .180" (4.57 mm).

CAUTION: Burr direction must be away from the direction of insertion.

TYPES AVAILABLE

<u>TYPE</u>	<u>CIRCUIT</u>	<u>ELECTRICAL RATING[†]</u>	<u>LISTING AGENCY^{††}</u>
Maintained Action			
GRS-2011-8, -13 -16	SPST	-8: 8 A @ 125 VAC / 4A @ 250 VAC -13: 13 A @ 125 VAC / 10 A @ 250 VAC	UL/CSA UL/CSA
GRS-2012-8, -13. -16	SPDT	1/2 HP 125 - 250 VAC 5 A @ 14V (T); 6 A @ 125 V (L) -16: 16 A @ 125 VAC / 12 A @ 250 VAC 3/4 HP @ 125 - 250 VAC 10 A @ 14 V (T); 12 (6) A @ 250-(VDE)	UL/CSA/VDE
Momentary Action			
GRS-2011B-8, -13	SPST (Normally Open)	-8: 8 A @ 125 VAC / 4A @ 250 VAC	UL/CSA
GRS-2011C-8, -13	SPST (Normally Closed)	-13: 13 A @ 125 VAC / 10 A @ 250 VAC 10 (4) A 250- μ (VDE)	UL/CSA/VDE
GRS-2012A-8, -13	SPDT Momentary		

[†]Additional ratings may be available, consult factory.

^{††}Due to ongoing advancements, additional agency certifications may be available, consult factory.

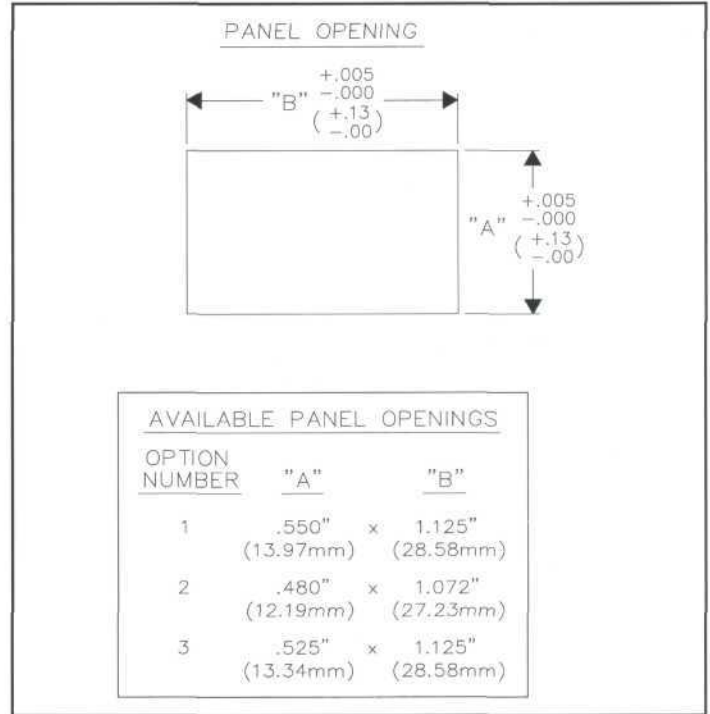
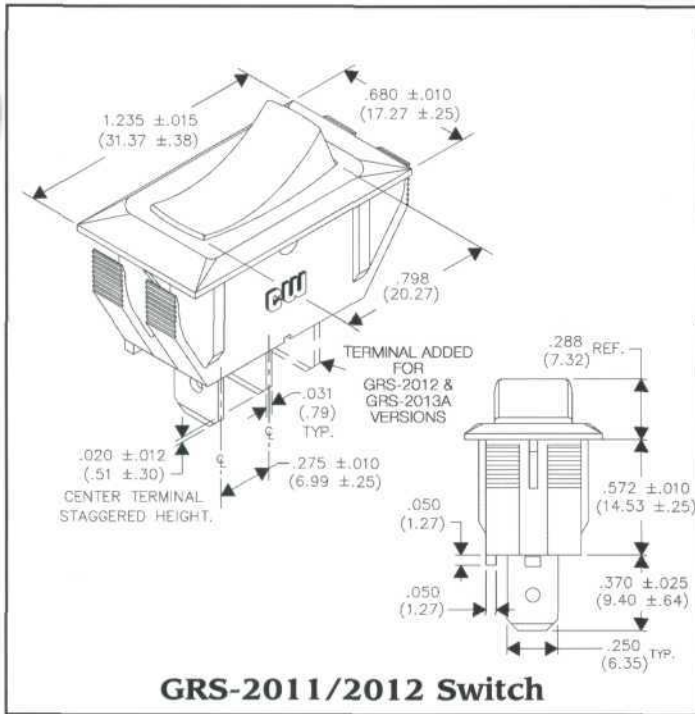

OPTIONAL FEATURES

TERMINATION:

Standard switches have a .250" (6.35 mm) blade terminals for solderless connection. For easier hand soldering, specify optional terminal G-20-190 having a .156" (3.96 mm) diameter hole in a .250" (6.35 mm) wide solder tab.

INSULATING BARRIERS:

Standard switch construction is without barriers. Optional molded insulating barriers between terminals, as shown at right, permit the use of uninsulated solderless connectors. Specify your switch "with barriers" if needed.

COLORS:

Our standard switch includes black housing and rocker knob. Knobs and housings can be molded in many colors. Contact us if you have unusual color needs.

SPECIAL MARKINGS:

Printing on the knob or housing indicating message appropriate to the application ("ON - OFF," "HI - LO," "I/O," etc.), is available. Check factory.

+Operating Standards and Materials described herein are general specifications that vary depending on the switch construction specified and end application. Consult factory for specifications for specific models. Specifications subject to change without notice.

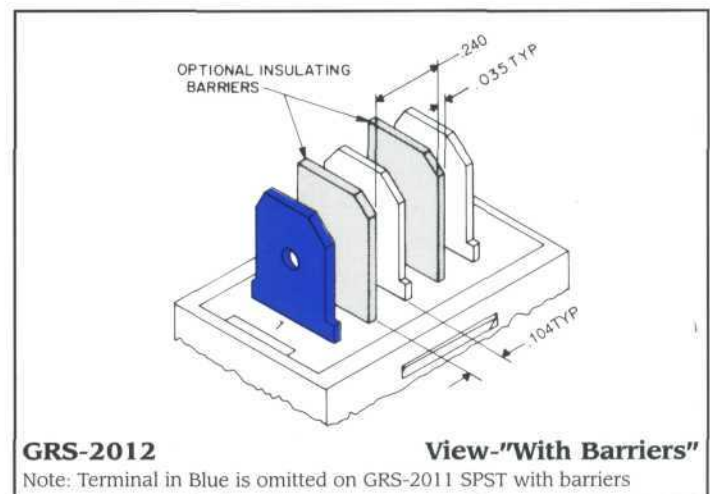

HOW TO ORDER

Step 1: Select type (see chart) that satisfies your maximum current requirements, either SPST or SPDT and maintained or momentary action.

Step 2: Select desired panel opening option number from chart above.

Step 3: Standard switch includes blade terminal and needs no added identification. If needed, specify optional solder terminal "G-20-190."

Step 4: Standard switch construction is without barriers. If needed specify "with barriers" for insulating barriers between terminals.

Step 5: Standard switch is all black. For special housing or knob color, or markings, contact factory for part number designation.

2000 Series: StyleLine™ Rocker Switches



2000 Series StyleLine™

CW's GRS-2000 Series StyleLine™ Rocker Switches, available in SPST, SPDT, and SPDT-Center Off versions, are specially designed to meet contemporary product styling and global appearance trends. The contoured design and slim attractive profile of the switch knob and bezel provide superior styling, and are available in both high-gloss and matte finish. Although they provide an attractive, slim appearance, the switches snap into the standard size openings of other 2000 Series Rocker Switches. In addition to great looks, StyleLine™ Rockers also provide the high quality and reliability you have come to expect from CW rocker switches. StyleLine™ Rockers are a great way to enhance the style of a new product or upgrade the appearance of an existing one. They are ideal for appliances, recreational equipment, medical and scientific devices, testing equipment, security systems, computers and peripherals, and many other products where performance and style are important.

OPERATING STANDARDS, MATERIALS OF CONSTRUCTION, and TERMINATION, INSULATING BARRIER, COLOR, and MARKING options are the same as those for the 2000 Series as described on pages 8 and 9.

FINISH

Available in both **high-gloss** and **matte** finish.



MOUNTING

No hardware or tools needed; self locks into a .550" (13.97 mm) x 1.125" (28.58 mm) panel cutout. Acceptable panel thickness range from .025" (.64 mm) to .180" (4.57 mm).

CAUTION: Burr direction must be away from the direction of insertion.

HOW TO ORDER

- Step 1:** Select type (see chart) either SPST, SPDT, or SPDT-CO, that satisfies your switching requirement.
- Step 2:** Select either "high-gloss" or "matte" finish.
- Step 3:** Standard switch includes blade terminal and needs no added identification. If needed, specify optional solder terminal "G-20-190".
- Step 4:** Standard switch construction is without barriers. If needed specify "with barriers" for insulating barriers between terminals.
- Step 5:** Standard switch is all black. For special colors or markings, contact factory for part number designation.

TYPES AVAILABLE

TYPE	CIRCUIT	ELECTRICAL RATING	LISTING AGENCY†
Matte Finish			
GRS-2011-24 Series	SPST	16 A @ 125 VAC / 12 A @ 250 VAC	UL/CSA/VDE
GRS-2012-24 Series	SPDT	3/4 HP @ 125 - 250 VAC	
GRS-2013A-24 Series	SPDT-CO (on - OFF - on)	10 A @ 14 V (T)	
High-Gloss Finish		12 (6) A @ 250-(VDE)	
GRS-2011-25 Series	SPST		
GRS-2012-25 Series	SPDT		
GRS-2013A-25 Series	SPDT-CO (on - OFF - on)		

†Due to ongoing advancements, additional agency certifications may be available, consult factory.

2000 Series: Center-Off Rocker Switches

CW's GRS-2013 Rocker Switches provide center-off three-position switching of up to 16.0 amps in styling compatible with CW two-position 2000 Series Rocker Switches. You may choose Type GRS-2013A having crisp detent action from each of three positions. Or you may need detent one end position to center, and momentary other end position to center-type GRS-2013B. Also available is type GRS-2013C-momentary each end to center. Materials used, termination options, and operating standards are the same as described for 2000 Series Rocker Switches featured on pages 8 and 9.

MOUNTING

Snaps easily into a .550" (13.97 mm) x 1.125" (28.58 mm) panel cutout ranging in thickness from .025" (0.64 mm) to .170" (4.32 mm). No need for tools or additional hardware.

CAUTION: Burr direction must be away from the direction of insertion.

HOW TO ORDER

Step 1: Select part number that provides combination of detent or momentary actuation and maximum current required.

Step 2: Standard switches have .250" (6.35 mm) blade terminals for solderless connection and need no added identification. For hand soldering, specify terminal G-20-171 which has a .156" (3.96 mm) diameter hole.

Step 3: Standard switch construction is without barriers. If needed specify "with barriers" for insulating barriers between terminals.

FEATURES

- Easy self-locking panel mount - no mounting hardware required
- Light, yet positive detent action - virtually tease-proof
- Heavy-duty switching - up to 16 A, 125 VAC
- Metal plunger resists high temperature
- Active switching elements enclosed and protected

GRS-2013 Switch

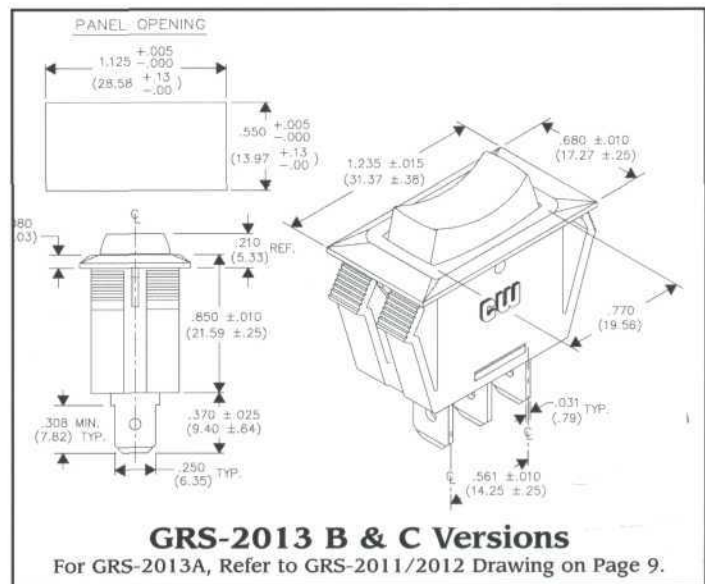

TYPES AVAILABLE

TYPE	CIRCUIT	ELECTRICAL RATING†	LISTING AGENCY††
*GRS-2013A-8, -13, -16	SPDT-CO (on-OFF-on)	-8: 8 A @ 125 VAC / 4A @ 250 VAC 3 A @ 277 VAC	UL/CSA
GRS-2013B-8, -13	SPDT-CO (mom-OFF-on)	-13: 13 A @ 125 VAC / 10 A @ 250 VAC 1/2 HP 125 - 250 VAC 5 A @ 14 V (T) 6 A @ 125 V (L) 10(4) A @ 250 ~ (VDE)**	UL/CSA/VDE
GRS-2013C-8, -13	SPDT-CO (mom-OFF-mom)	-16: 16 A @ 125 VAC / 12 A @ 250 VAC 3/4 HP 125 - 250 VAC 10 A @ 14 V (T) 12(6) A @ 250 ~ (VDE)	UL/CSA/VDE

†Additional ratings may be available, consult factory.

††Due to ongoing advancements, additional agency certifications may be available, consult factory.

*See detail GRS-2012, page 9 for "A" version.

**Applies only to GRS-2013B/C

NOTE: Momentary = mom

2000 Series: Illuminated Rocker Switches

CW's Type GRL-2011 SPST Lighted Rocker Switch is designed for user needs - easy to mount, easy to terminate, and easy to actuate... plus immediate identification of its "OFF" and "ON" positions.

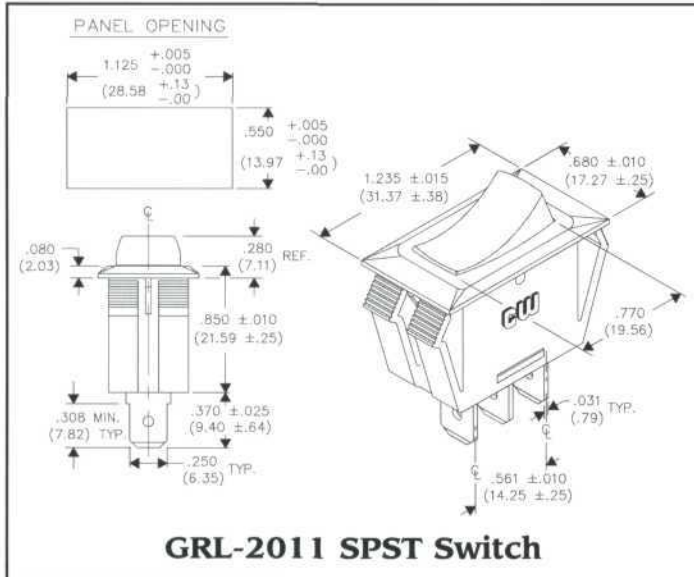

OPERATING STANDARDS, MOUNTING, and TERMINATION and INSULATING BARRIER options are the same for GRS-2000 Series as described on pages 8 & 9.

COLORS:

Standard switch includes black housing and red transparent rocker knob. For design flexibility the switch housing can be molded in many popular colors. Also, translucent or transparent rocker knobs are available in a variety of colors. Contact the factory for details.

LAMP TYPES:

Standard is neon lamp type A1C, a 1/7 watt high output bulb, dark effect reduced for 125 volt applications.

Optional are neon lamps for 250 volt application, and incandescent lamps for 14 volt applications.

FEATURES

- Heavy duty switching
- Choice of colors
- Easy self-locking panel mount - no mounting hardware required
- Bright neon bulb clearly indicates "ON" position
- Fully enclosed active switching elements
- Unique combination sliding and rotating action ensures contact cleanliness
- Light, yet positive detent action - virtually tease-proof

GRL-2011 Switch

Wiring Diagram

Terminal Number

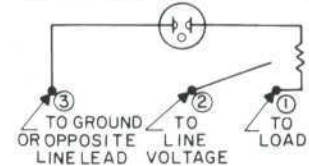

MATERIALS

Rocker Knob: Transparent polycarbonate (standard) or translucent nylon 6/6 (optional)

Rocker Lamp: High intensity neon lamp type A1C with 1/4 watt 22kΩ resistor, with 10,000 hours of life for 125 volt applications (standard)

Housing & Terminal Board: Nylon 94V-2

Terminal & Moving Contact: Copper

HOW TO ORDER

Step 1: Select part number that satisfies your maximum current needs.

Step 2: No added identification is required for standard 125 volt high light output neon lamp. Specify optional lamp if desired.

Step 3: Standard construction is without barriers. Specify "with barriers" if required.

Step 4: Standard switch has black housing and transparent red rocker knob. For special colors or knob materials, contact factory.

Step 5: Standard switch has .250" (6.35 mm) blade terminals for solderless connection. Specify optional terminal if required.

TYPES AVAILABLE

TYPE	CIRCUIT	ELECTRICAL RATING†	LISTING AGENCY††
GRL-2011-8, -13, -16	SPST	-8: 8 A @ 125 VAC / 4 A @ 250 VAC 3 A @ 277 VAC	UL/CSA
		-13: 13 A @ 125 VAC / 10 A @ 250 VAC	UL/CSA
		-16: 16 A @ 125 VAC / 12 A @ 250 VAC 3/4 HP 125 - 250 VAC 12(6) A @ 250 ~ (VDE)	UL/CSA/VDE

†Additional ratings may be available, consult factory.

††Due to ongoing advancements, additional agency certifications may be available, consult factory.

2000 Series: Double-Pole Rocker Switches

GR-2021, 2022, & 2023 Double-Pole Rocker Switches offer maintained, momentary and center-off switching options for high Amp applications in double-pole construction. These Double-Pole Rocker Switches have the same construction, materials, operating standards, and optional features as 2000 Series Rocker Switches described on pages 8 and 9.

FEATURES

- Switch "pops" into panel - no mounting hardware required
- Metal plunger for high temperature
- Quick connect terminals for simplified termination
- Heavy-duty switching - 8 A, 13 A or 16 A per pole @ 125 VAC
- Choice of colors and markings
- Available in spring return and center off versions
- Crisp detent action
- Patented combination sliding and rotating action maintains contact cleanliness

GR-2022 DPDT Switch

Note: Terminals in Blue are omitted on GR-2021 DPST.

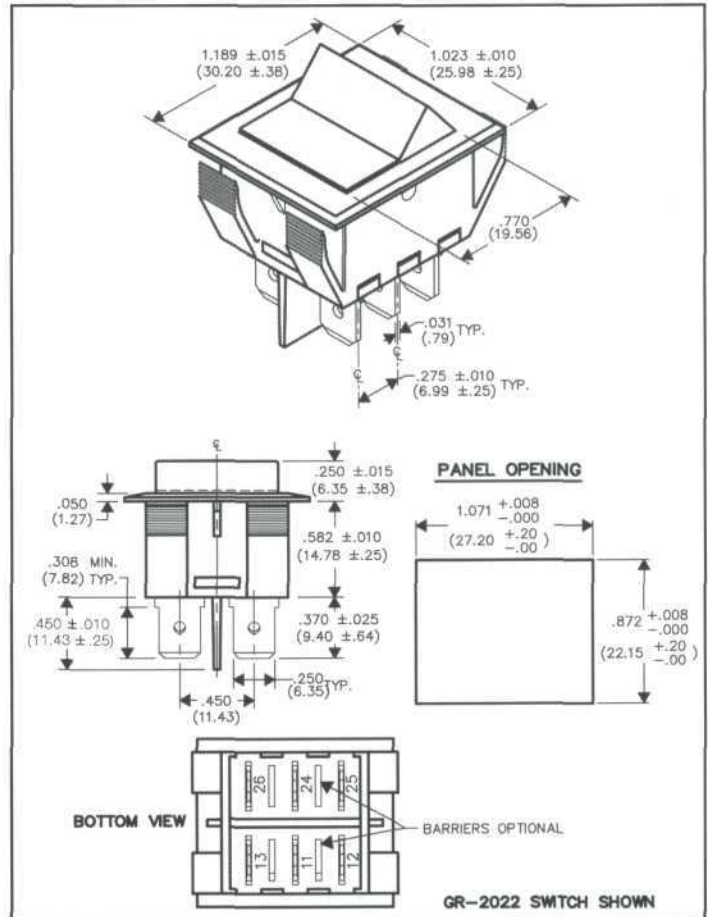

MOUNTING

No tools or hardware required. Snaps into 1.071" (27.20 mm) x .872" (22.15 mm) panel cutout, as shown on drawing. Acceptable panel thickness .025" (0.64 mm) to .150" (3.81 mm).

CAUTION: Burr direction must be away from direction of insertion.

HOW TO ORDER

- Step 1:** Select part number for your circuit needs and maximum current requirements.
- Step 2:** Standard switch color is all black. Specify optional knob or housing colors and any special markings required.
- Step 3:** Standard terminal is solderless .250" (6.35 mm) wide and needs no further identification. Specify optional solder terminal G-20-164 if needed.
- Step 4:** Insulating barrier between terminals on opposite poles is standard. Specify "with barriers" for barriers between terminals of the same pole.

TYPES AVAILABLE

TYPE	CIRCUIT	ELECTRICAL RATING†	LISTING AGENCY††
Maintained Action			
GR-2021-8, -13, -16	DPST	-8: 8 A @ 125 VAC / 4 A @ 250 VAC 3 A @ 277 VAC	UL/CSA
GR-2022-8, -13, -16	DPST	-13: 13 A @ 125 VAC / 10 A @ 250 VAC 1/2 HP 125 - 250 VAC 6 A @ 125 V (L) 5 A @ 14V (T)	UL/CSA
Momentary Action			
GR-2021B-8, -13, -16	DPST (Normally Open)		
GR-2021C-8, -13, -16	DPST (Normally Closed)		
GRS-2022A-8, -13, -16	DPDT	-16: 16 A @ 125 VAC / 12 A @ 250 VAC 3/4 HP 125 - 250 VAC 10 A @ 14 V (T) 12 (6) A @ 250 ~ (VDE)	UL/CSA/VDE
Center Off			
GR-2023A-8, -13, -16	DPDT-CO		
GR-2023B-8, -13, -16	DPDT (mom-OFF-on)		
GR-2023C-8, -13, -16	DPDT-CO (mom-OFF-mom)		

†All ratings are based on a load per pole, opposite polarity basis. Additional ratings may be available, consult factory.
 ††Due to ongoing advancements, additional agency certifications may be available, consult factory.
 NOTE: Momentary = mom

Power Slide Switches

CW's heavy-duty Power Slide Switches open up higher current devices to the use of the popular slide switch platform. Options include: SPST or SPDT circuitry, traditional metal or fully-enclosed plastic construction, and snap-in or chassis mount styles. These compact switches are easy to install, easy to use, and with a rating up to 16 Amps are an ideal alternative to expensive high current industrial switches.

GF-1623 POWER SLIDE SWITCH

OPERATING STANDARDS⁺

Endurance:

100,000 cycles, no load, minimum
6,000 cycles at rated load, minimum

Contact Resistance:

Less than .01 Ω at 10 mA

Operating Temperature:

From 65°C - 105°C maximum

High Voltage:

1,000 V, 60 Hz for 1 minute between parts of opposite polarity

Relative Humidity:

Insulation resistance > 100 M Ω after 100 hours at 95% R.H. and 50°C followed by 1 hour dry at ambient room conditions

MATERIALS⁺

Button: Type 6/6 Nylon. Black is standard, for other colors consult factory. .344" (8.74 mm) high button is standard other heights available, consult factory. Optional button toppers available as shown on page 15.

Housing: Steel, zinc plated

Moving Contact: Copper alloy, silver plated

Moving Contact Spring: Phosphor bronze

Terminal: Copper alloy, .187" (4.75 mm) blade terminals for solderless connection

Terminal Board: Phenolic Laminate

MOUNTING

Two .140" diameter holes on 1.125" centers

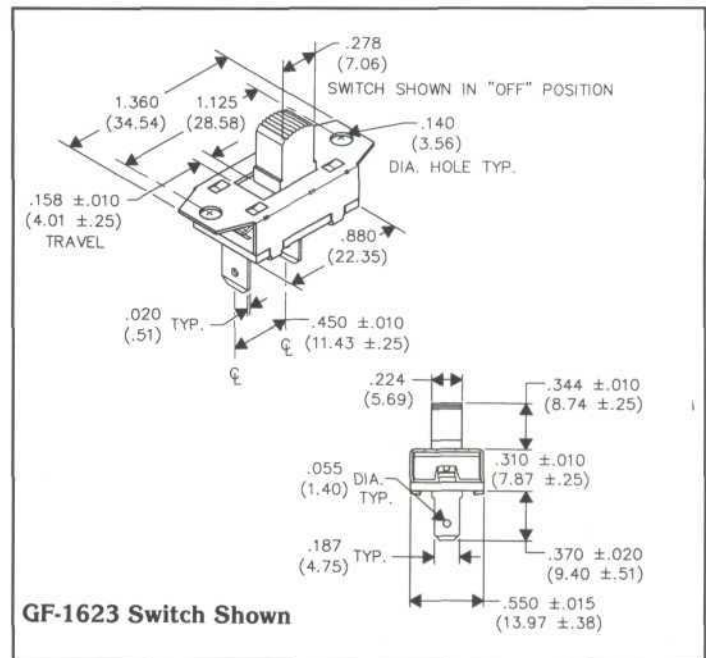
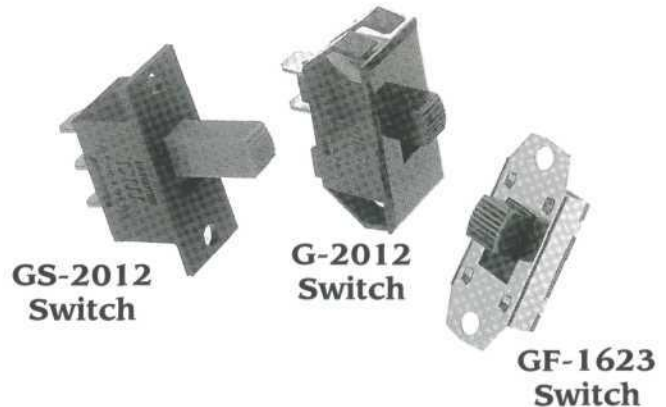

⁺Operating Standards and Materials described herein are general specifications that vary depending on the switch construction specified and end application. Consult factory for specifications for specific models. Specifications subject to change without notice.

TYPES AVAILABLE			
TYPE	CIRCUIT	ELECTRICAL RATING	LISTING AGENCY
GF-1623	SPST	16 A @ 125 VAC 8 A @ 250 VAC	UL/CSA

G/GS-2011 & G/GS-2012 POWER SLIDE SWITCHES

OPERATING STANDARDS, MATERIALS, and OPTIONAL FEATURES are the same as 2000 Series Rocker Switches described on pages 8 and 9.

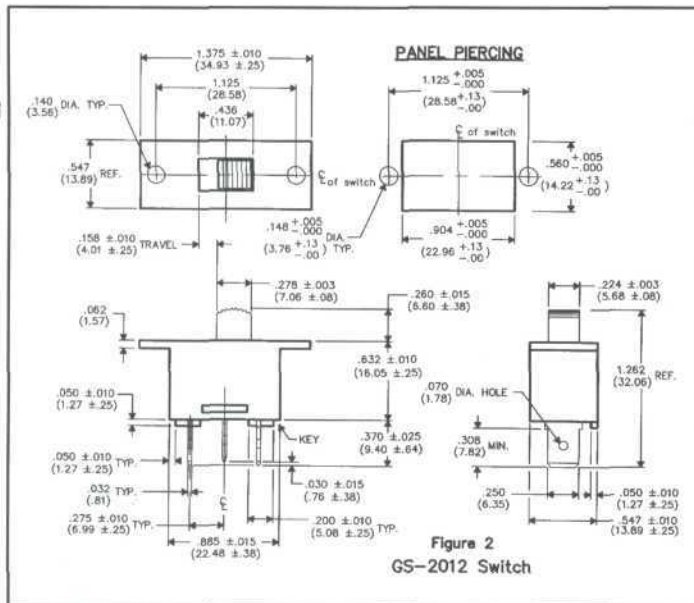
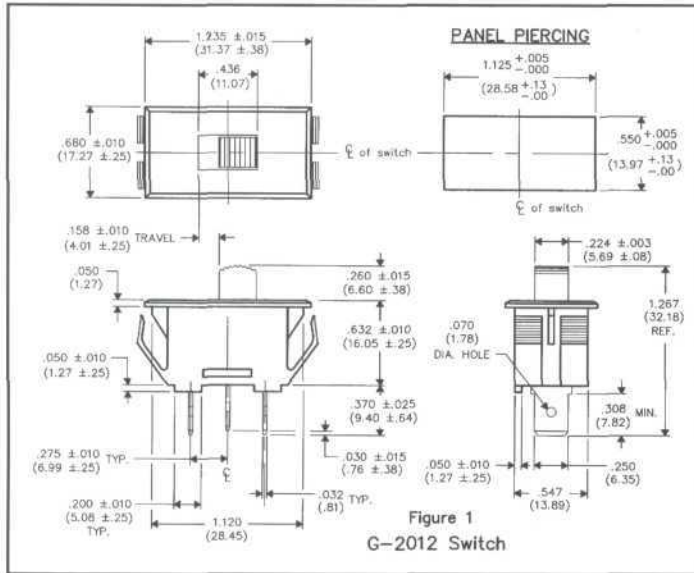

FEATURES

- Choice of colors and markings
- Light, yet positive detent action - virtually tease-proof
- Fully enclosed active switching elements
- Easy self-locking panel mount - no mounting hardware required
- Unique combination sliding and rotating action ensures contact cleanliness

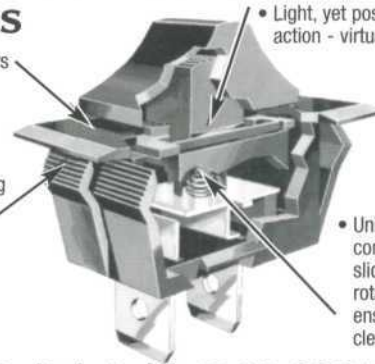

G-2011 Switch (with G-02-329 Topper)

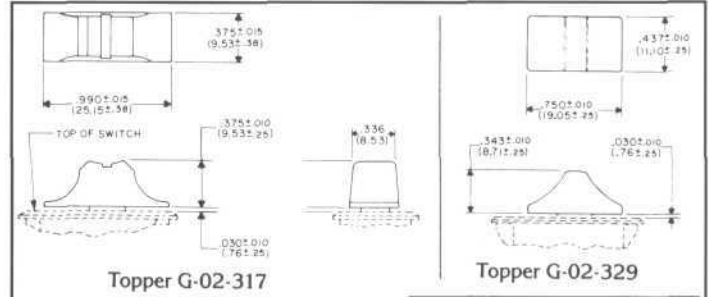

Change your panel appearance. Drawings show topers oriented to switches having standard .260" (6.60 mm) high button. Optional heights available are .344" (8.74 mm), .500" (12.70 mm), .625" (15.88 mm), and .750" (19.05 mm). As button height increases above .260" (6.60 mm), clearance between topper and housing changes accordingly.

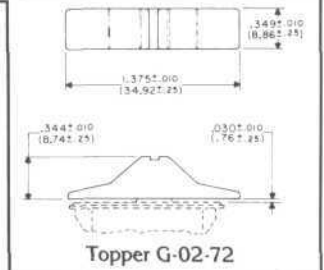

HOW TO ORDER

- Step 1:** Select part number that satisfies your maximum current requirements, either SPST or SPDT. Specify "G" for Pop-in Mount (figure 1) or "GS" for Slide Switch with mounting tabs (figure 2).
- Step 2:** Standard switch includes blade terminal and needs no added identification. If needed, specify optional solder terminal.
- Step 3:** Standard switch construction is without barriers. If needed, specify "with barriers" between terminals. Barriers available in 2012 versions only.
- Step 4:** Standard switch is all black. For special housing or knob color or markings, contact factory for part number designation.

TYPES AVAILABLE

TYPE	CIRCUIT	ELECTRICAL RATING†	LISTING AGENCY
G-2011-8/GS-2011-8	SPST	8 A @ 125 VAC	UL/CSA
G-2012-8/GS-2012-8	SPDT	4 A @ 250 VAC	
G-2011-13/GS-2011-13	SPST	13 A @ 125 VAC	UL/CSA
G-2012-13/GS-2012-13	SPDT	10 A @ 250 VAC 1/2 HP 125 - 250 VAC 5 A @ 14 V (T) 6 A @ 125 V (L)	
G-2011-16/GS-2011-16	SPST	16 A @ 125 VAC	UL/CSA/VDE
G-2012-16/GS-2012-16	SPDT	12 A @ 250 VAC 3/4 HP 125 - 250 VAC 10 A @ 14 V (T) 12 (6) A @ 250 ~ (VDE)	

†Additional ratings may be available, specify your unique requirements.

General Information

CARE IN USE OF SWITCHES

CW switches will perform properly if they are installed and used properly. Causes for failure often encountered in the field that are the responsibility of the user are:

1. Removal of factory applied lubricants from switch contacts and moving parts.
2. Introduction of foreign material into switching mechanism... flux, solder, cleaning materials, potting compound.
3. Restriction of movement of switch button.
4. Excessive heat often introduced while soldering.
5. Switching loads in excess of rating.

Users are cautioned to avoid misusing switches and to test and approve switches for acceptability in end application. CW has no knowledge of and makes no representation with respect to the usefulness and/or merchantability of any product that is made to buyers special engineering specifications.

COMPONENT RECOGNITION

CW Switches, when so identified, are recognized under the Component Recognition Program of Underwriters Laboratories Inc. (File E 9556), and certified by the Canadian Standards Association (File LR 20985), and approved and certified by Verband Deutscher Elektrotechniker (V.D.E. of West Germany (File 11620). Due to ongoing advancements, additional agency certifications may be available, consult factory.

OTHER CW SWITCHES

CW manufactures a comprehensive array of slide, rocker, and momentary switches. Sizes range from microminiature to larger switches capable of switching up to 16 amps per pole. One to four poles and two to five position switches are included. Advise us of your switch problems. We'll forward you catalogs that will help solve them.

CW IDC CONNECTORS

CW Industries also manufactures a comprehensive product line of insulation displacement connectors designed for mass termination. CW's patented Torq-Tite™ contact provides complete connection reliability between conductor and contact. This is available in DIP, Card Edge, PCB, Subminiature "D"s and Socket IDC connectors. Mating Headers also are part of this CW product line. Parts are approved for both military and commercial application. Send for Catalog C 2110.

CUSTOM DESIGNED SWITCHES

CW's objective is to design a quality product that can be mass produced efficiently, making possible a competitive stance in the worldwide electrical component marketplace. If our standard product does not quite solve your mechanical, electrical, or styling problems, we seek the opportunity of adapting our expertise to your unusual or unique needs. Please call, fax, or email us or our sales representative in your area.

CW PATENTS

CW Engineers constantly upgrade the quality and cost effectiveness of our switches. Often this result in new inventions. Switch products shown in this catalog may be covered by one or more U.S. Patents. Other patent applications are pending.

To see what's **NEW** and **HOT** at CW Industries,
visit us on the web at
www.cwind.com

Also Available from CW

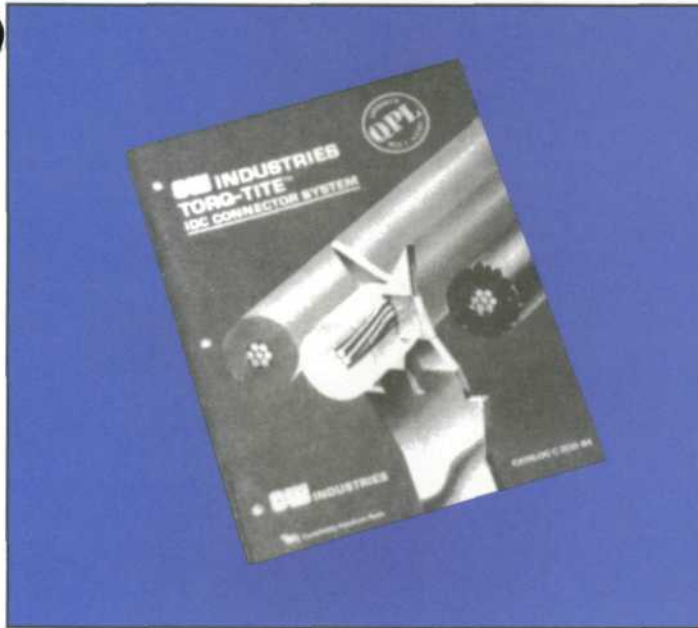

CW TORQ-TITE™ IDC CONNECTOR SYSTEM CATALOG

Details CW's complete line of .050" center IDC cable and connectors for mass termination, featuring the patented Torq-Tite™ contact for gas-tight connections. Catalog includes comprehensive design and application data on DIPs, PCBs, sockets, headers, card-edge and D-subminiature connectors, as well as cable and assembly tooling. Connectors are UL, CSA and QPL listed under MIL-C-B3503 and MILC-2430B. Reference data on material selection and shielding techniques for EMI/RFI protection is included.

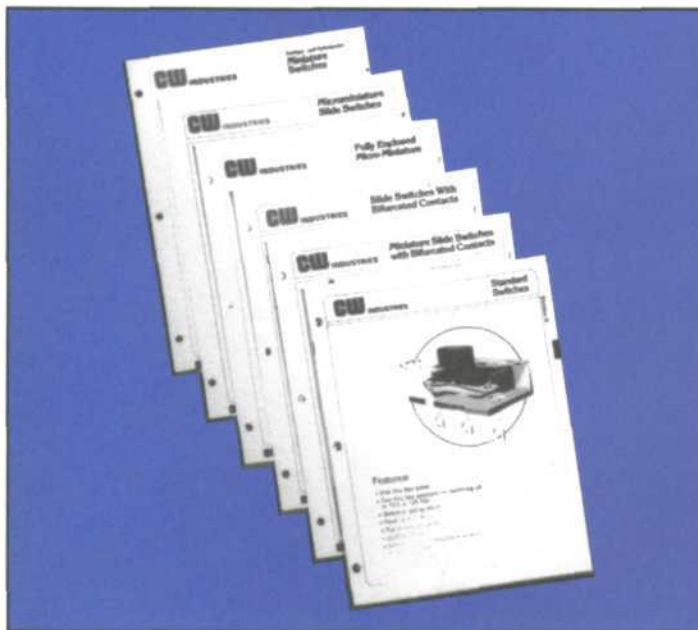

CW SLIDE SWITCH CATALOGS

Details the complete line from the largest manufacturer of slide switches in the U.S. Catalogs contain comprehensive design and application information on miniature and microminiature slide switches-top, side and end-actuated for panel or PC board mountings with wide variety of circuitry options from .5 amp to 13 amps; UL and CSA listed. Also featured are designs with bifurcated contacts for high reliability in low current applications and fully-enclosed microminiature switches for total environmental protection.

About CW

Our history dates from the earliest days of electronics.

The Wirt Company was founded in 1904 by Charles Wirt, an associate of Thomas Alva Edison. Wirt pioneered the development of wirewound potentiometers, fixed wirewound resistors, automatic spark suppressors and slide switches. At the same time, engineers at Continental Carbon, Inc., were creating basic processes for manufacturing carbon composition resistors, pyrolytic metal film resistors and carbon film resistors. Following their merger, Continental Carbon, Inc. and The Wirt Company became Continental-Wirt Electronics Corporation and more recently, CW Industries. As CW Industries, we have developed patented products and processes for several segments of our industry. These products include microminiature switches, potentiometers, evaporated thin film resistors, custom connectors, as well as insulation displacement connectors.

We are vertically integrated. In addition to engineering each of our basic designs and patented features, we mold, stamp and plate, in-house, virtually every component used in each of our products. We design and build our own molds and contact dies, as well as most of our assembly equipment. We even have an environmental testing laboratory, qualified by Defense Electronics Supply Center and Underwriters Laboratories, to perform in-plant testing.

Our facilities and our experienced personnel enable us to properly control every phase of the manufacturing process required to convert raw materials into finished components. This vertical integration allows us to consistently manufacture reliable products with a significant advantage in design, quality, performance, delivery and overall cost.

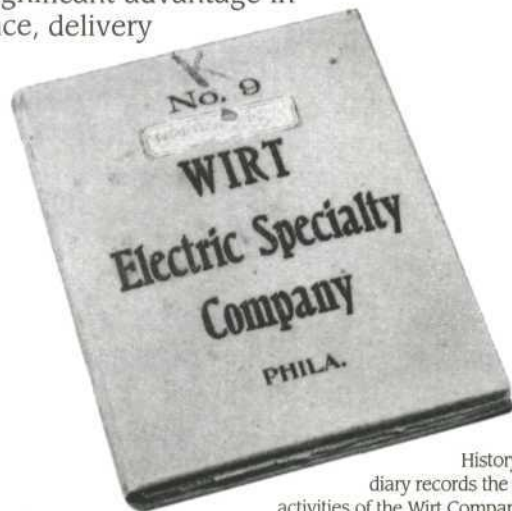

History on paper. This drafting room diary records the engineering department activities of the Wirt Company in the year 1912.

Visit us on the web at
www.cwind.com



Компания «Life Electronics» занимается поставками электронных компонентов импортного и отечественного производства от производителей и со складов крупных дистрибьюторов Европы, Америки и Азии.

С конца 2013 года компания активно расширяет линейку поставок компонентов по направлению коаксиальный кабель, кварцевые генераторы и конденсаторы (керамические, пленочные, электролитические), за счёт заключения дистрибьюторских договоров

Мы предлагаем:

- Конкурентоспособные цены и скидки постоянным клиентам.
- Специальные условия для постоянных клиентов.
- Подбор аналогов.
- Поставку компонентов в любых объемах, удовлетворяющих вашим потребностям.
- Приемлемые сроки поставки, возможна ускоренная поставка.
- Доставку товара в любую точку России и стран СНГ.
- Комплексную поставку.
- Работу по проектам и поставку образцов.
- Формирование склада под заказчика.
- Сертификаты соответствия на поставляемую продукцию (по желанию клиента).
- Тестирование поставляемой продукции.
- Поставку компонентов, требующих военную и космическую приемку.
- Входной контроль качества.
- Наличие сертификата ISO.

В составе нашей компании организован Конструкторский отдел, призванный помогать разработчикам, и инженерам.

Конструкторский отдел помогает осуществить:

- Регистрацию проекта у производителя компонентов.
- Техническую поддержку проекта.
- Защиту от снятия компонента с производства.
- Оценку стоимости проекта по компонентам.
- Изготовление тестовой платы монтаж и пусконаладочные работы.



Тел: +7 (812) 336 43 04 (многоканальный)
Email: org@lifeelectronics.ru