

MOD-RTC development board USER'S MANUAL

Initial release, May 2012
Designed by OLIMEX Ltd, 2011



All boards produced by Olimex LTD are ROHS compliant

Disclaimer:

© 2012 Olimex Ltd. Olimex®, logo and combinations thereof, are registered trademarks of Olimex Ltd. Other terms and product names may be trademarks of others.

The information in this document is provided in connection with Olimex products. No license, express or implied or otherwise, to any intellectual property right is granted by this document or in connection with the sale of Olimex products.

Neither the whole nor any part of the information contained in or the product described in this document may be adapted or reproduced in any material form except with the prior written permission of the copyright holder.

The product described in this document is subject to continuous development and improvements. All particulars of the product and its use contained in this document are given by OLIMEX in good faith. However all warranties implied or expressed including but not limited to implied warranties of merchantability or fitness for purpose are excluded. This document is intended only to assist the reader in the use of the product. OLIMEX Ltd. shall not be liable for any loss or damage arising from the use of any information in this document or any error or omission in such information or any incorrect use of the product.

**Thank you for purchasing MOD-RTC development board assembled by
OLIMEX LTD**

Table of Contents

CHAPTER 1.....	5
OVERVIEW.....	5
1. Introduction to the chapter.....	5
1.1 Features.....	5
CHAPTER 2	6
SETTING UP THE MOD-RTC MODULE.....	6
2. Introduction to the chapter.....	6
2.1 Electrostatic warning.....	6
2.2 Requirements.....	6
2.3 Powering the module.....	6
2.4 Duinomite note.....	6
CHAPTER 3.....	8
MOD-RTC BOARD DESCRIPTION.....	8
3. Introduction to the chapter.....	8
3.1 Layout (bottom view).....	8
CHAPTER 4.....	9
THE PCF8563 CMOS REAL-TIME CLOCK.....	9
4. Introduction to the chapter.....	9
4.1 The PCF8563.....	9
CHAPTER 5	10
CONTROL CIRCUITY.....	10
5. Introduction to the chapter.....	10
5.1 Reset.....	10
5.2 Clock	10
CHAPTER 6.....	11
HARDWARE.....	11
6. Introduction to the chapter.....	11
6.1 BAT connector.....	11
6.2 UEXT.....	11
6.3 Jumper description.....	12
CHAPTER 7.....	13
SCHEMATICS.....	13
7. Introduction to the chapter.....	13
7.1 Eagle schematic.....	13
7.2 Physical dimensions.....	15

CHAPTER 8.....16
REVISION HISTORY.....16
 8. Introduction to the chapter.....16
 8.1 Document revision.....16
 8.2 Web page of your device.....16

CHAPTER 1

OVERVIEW

1. Introduction to the chapter

Thank you for choosing the MOD-RTC extension module from Olimex!

This device is a tiny implementation of NXP's real-time clock/calendar chip PCF8563. The main purpose of MOD-RTC is adding real-time clock to another Olimex board via the UEXT connector without the need of a hardware modification.

1.1 Features

- PCF8536 Real time clock
 - Lithium 3V battery connector
 - UEXT connector
 - FR-4, 1.5 mm, soldermask, component print
 - Dimensions: 40x19mm (1.57 x 0.75")
-

CHAPTER 2

SETTING UP THE MOD-RTC MODULE

2. Introduction to the chapter

This section helps you set up the MOD-RTC development board for the first time.

Please consider first the electrostatic warning to avoid damaging the board, then discover the hardware and software required to operate the board.

The procedure to power up the board is given, and a description of the default board behavior is detailed.

2.1 Electrostatic warning

MOD-RTC is shipped in a protective anti-static package. The board must not be exposed to high electrostatic potentials. A grounding strap or similar protective device should be worn when handling the board. Avoid touching the component pins or any other metallic element.

2.2 Requirements

In order to set up the MOD-RTC, the following items are required:

- MOD-RTC module itself
- an OLIMEX board to use as a host (Note that it is possible to use another board without UEXT but that might cost you the ease of use – e.g. you will have to manually connect wires in the proper order)

Additionally if your host board can't provide 3.3V on the UEXT connector you will need 3V battery able to power the module.

2.3 Powering the module

The module is powered either by the UEXT of a host board or by a battery. It required at least 3V.

2.4 Duinomite note

Duinomite has prebuilt support for MOD-RTC in firmwares prior to firmware version 3.x. There is a high chance that the support for MOD-RTC is implemented by the time you are reading, however,

but it is not guaranteed.

All you have to do is write “setup” command and change “RTC on Boot”. Check the pictures below:

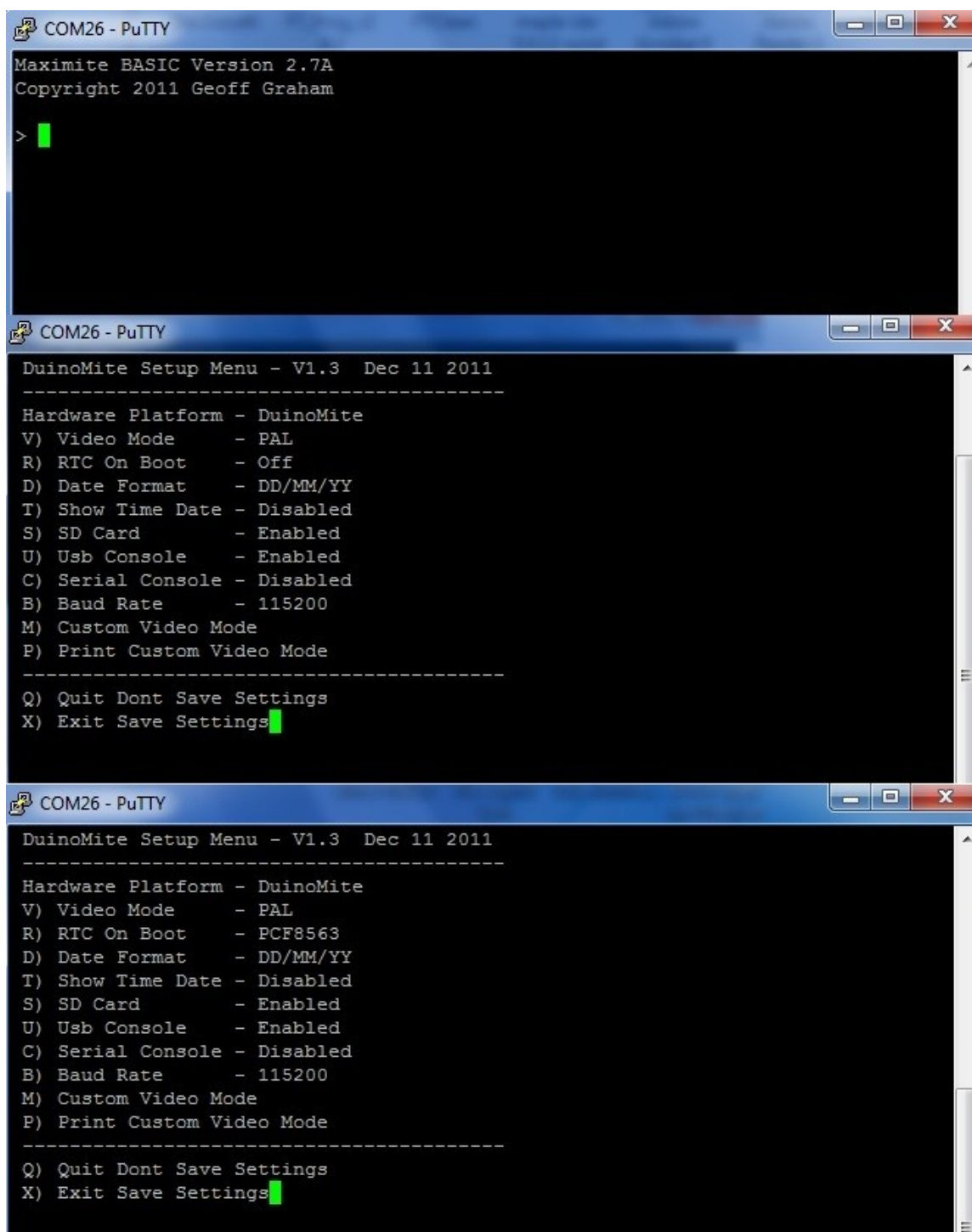

CHAPTER 3

MOD-RTC BOARD DESCRIPTION

3. Introduction to the chapter

Here you get acquainted with the main parts of the board. Note the names used on the board differ from the names used to describe them. For the actual names check the MOD-RTC board itself.

3.1 Layout (bottom view)

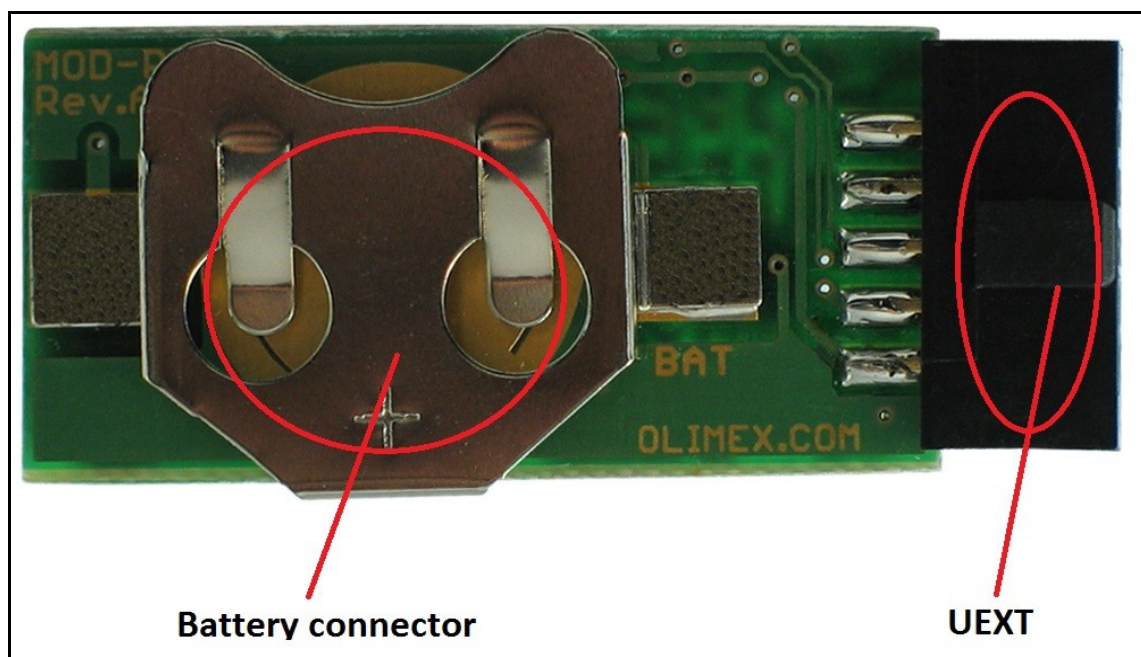

CHAPTER 4

THE PCF8563 CMOS REAL-TIME CLOCK

4. Introduction to the chapter

In this chapter is located the information about the heart of MOD-RTC. The information is a modified version of the datasheet provided by its manufacturers.

4.1 The PCF8563

- Provides year, month, day, weekday, hours, minutes, and seconds based on
- 32.768 kHz quartz crystal
- Century flag
- Clock operating voltage: 1.0 V to 5.5 V at room temperature
- Low backup current; typical 0.25 μ A at VDD = 3.0 V and Tamb = 25 °C
- 400 kHz two-wire I2C-bus interface (at VDD = 1.8 V to 5.5 V)
- Programmable clock output for peripheral devices (32.768 kHz, 1.024 kHz, 32 Hz, and 1 Hz)
- Alarm and timer functions
- Integrated oscillator capacitor
- Internal Power-On Reset (POR)
- I2C-bus slave address: read A3h and write A2h
- Open-drain interrupt pin

For comprehensive information on the PCF8563 visit the NXP's web page for a datasheet. It is highly recommended to have a look at that datasheet.

At the moment of writing the microcontroller datasheet can be found at the following link:

http://www.nxp.com/documents/data_sheet/PCF8563.pdf

CHAPTER 5

CONTROL CIRCUITY

5. Introduction to the chapter

Here you can find information about reset circuit and quartz crystal locations.

5.1 Reset

The module lacks hardware reset.

5.2 Clock

Real time clock (RTC) Q2 is found at pins 1 and 2 of the PCF8563.

CHAPTER 6

HARDWARE

6. Introduction to the chapter

In this chapter are presented the connectors that can be found on the board all together with their pinout. Jumpers functions are described. Notes and info on specific peripherals are presented. Notes regarding the interfaces are given.

6.1 BAT connector

3V battery can be inserted to power the board externally. Insert the battery with its positive side top.



6.2 UEXT

MOD-RTC board has UEXT connector and can interface Olimex's UEXT modules. Since MOD-RTC is configured as a (slave) device it is advisable to be connected to a host device.

For more information on UEXT please visit:

<http://www.olimex.com/dev/OTHER/UEXT.pdf>

Pin #	Signal Name
1	+3.3V
2	GND
3	CLKOUT
4	#INT

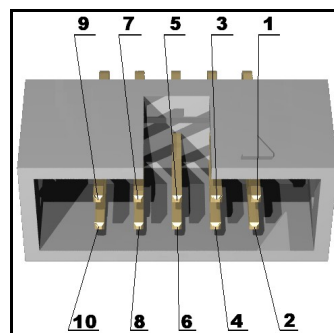

5	SCL
6	SDA
7	NOT CONNECTED
8	NOT CONNECTED
9	NOT CONNECTED
10	NOT CONNECTED

6.3 Jumper description

The module doesn't have any jumpers.

CHAPTER 7

SCHEMATICS

7. Introduction to the chapter

In this chapter are located the schematics describing logically and physically MOD-RTC.

7.1 Eagle schematic

MOD-RTC schematic is visible for reference here. You can also find them on the web page for MOD-RTC at our site: <http://www.olimex.com/dev/MOD-RTC.html>. They are located in HARDWARE section.

The EAGLE schematic is situated on the next page for quicker reference.

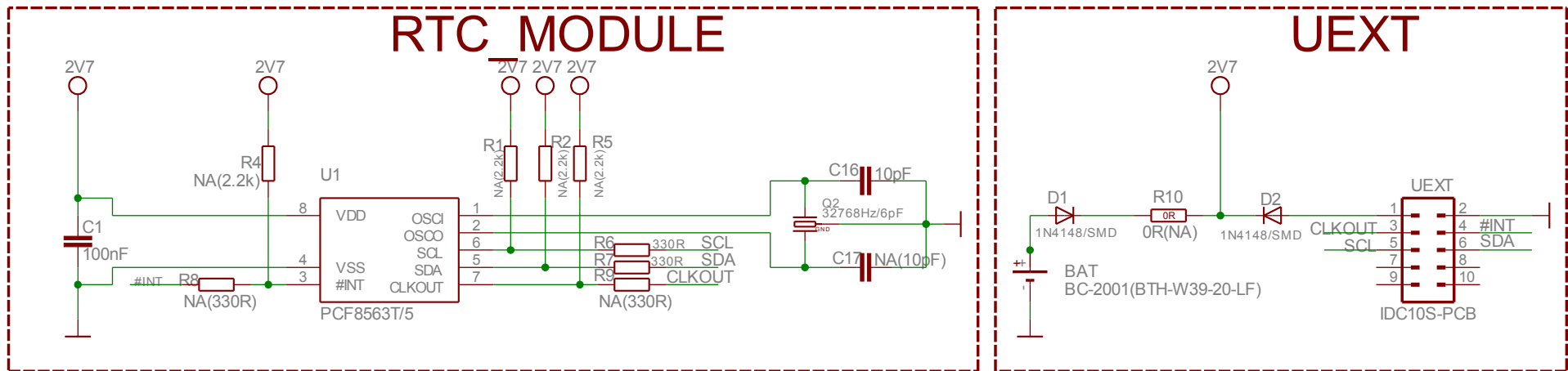

7.2 Physical dimensions

Note that all dimensions are in inches.

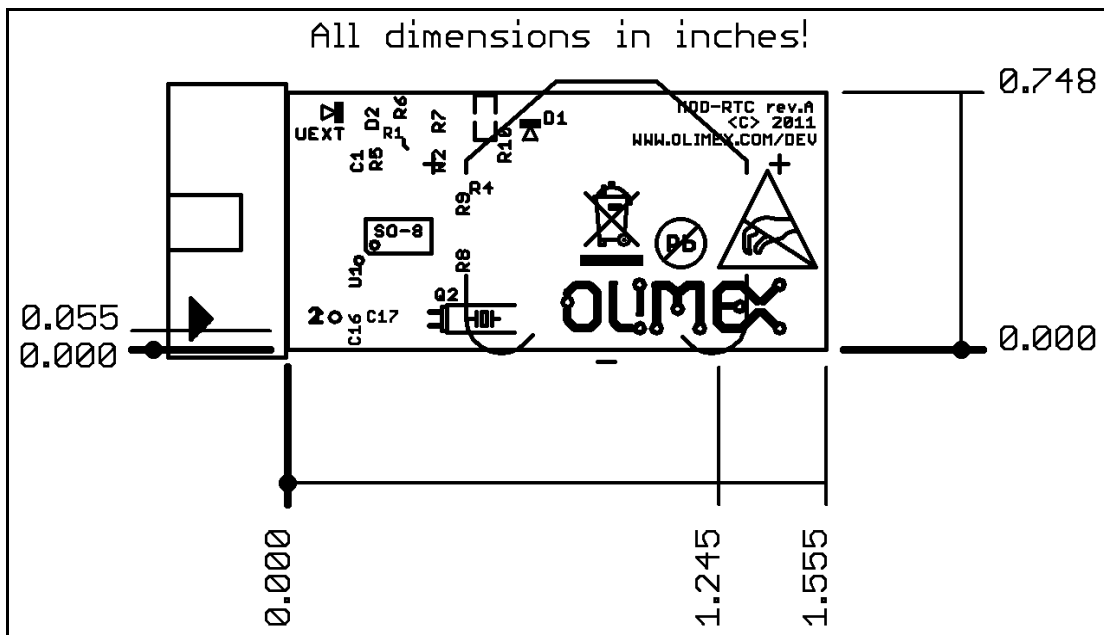

CHAPTER 8

REVISION HISTORY

8. Introduction to the chapter

In this chapter you will find the current and the previous version of the document you are reading. Also the web-page for your device is listed. Be sure to check it after a purchase for the latest available updates and examples.

8.1 Document revision

Revision	Changes	Modified Pages
A	Initial Creation	All

8.2 Web page of your device

The web page you can visit for more info on your device is <http://www.olimex.com/dev/MOD-RTC.html>. There you can find more info and some examples.

ORDER CODES:

MOD-RTC - completely assembled and tested

How to order?

You can order to us directly or by any of our distributors.

Check our webpage <http://www.olimex.com/> for more info.

Компания «Life Electronics» занимается поставками электронных компонентов импортного и отечественного производства от производителей и со складов крупных дистрибьюторов Европы, Америки и Азии.

С конца 2013 года компания активно расширяет линейку поставок компонентов по направлению коаксиальный кабель, кварцевые генераторы и конденсаторы (керамические, пленочные, электролитические), за счёт заключения дистрибьюторских договоров

Мы предлагаем:

- Конкурентоспособные цены и скидки постоянным клиентам.
- Специальные условия для постоянных клиентов.
- Подбор аналогов.
- Поставку компонентов в любых объемах, удовлетворяющих вашим потребностям.
- Приемлемые сроки поставки, возможна ускоренная поставка.
- Доставку товара в любую точку России и стран СНГ.
- Комплексную поставку.
- Работу по проектам и поставку образцов.
- Формирование склада под заказчика.
- Сертификаты соответствия на поставляемую продукцию (по желанию клиента).
- Тестирование поставляемой продукции.
- Поставку компонентов, требующих военную и космическую приемку.
- Входной контроль качества.
- Наличие сертификата ISO.

В составе нашей компании организован Конструкторский отдел, призванный помогать разработчикам, и инженерам.

Конструкторский отдел помогает осуществить:

- Регистрацию проекта у производителя компонентов.
- Техническую поддержку проекта.
- Защиту от снятия компонента с производства.
- Оценку стоимости проекта по компонентам.
- Изготовление тестовой платы монтаж и пусконаладочные работы.



Тел: +7 (812) 336 43 04 (многоканальный)

Email: org@lifeelectronics.ru