



MIC2169B

500kHz PWM Synchronous Buck Control IC

General Description

The MIC2169B is a high-efficiency, simple to use 500kHz PWM synchronous buck control IC housed in small MSOP-10 and MSOP-10 ePad packages. The MIC2169B allows compact DC/DC solutions with a minimal external component count and cost. The device features high-output driver capability to drive loads up to 30A.

The MIC2169B operates from a 3V to 14.5V input, without the need of any additional bias voltage. The output voltage can be precisely regulated down to 0.8V. The adaptive all N-Channel MOSFET drive scheme allows efficiencies over 95% across a wide load range within the smallest possible printed circuit board space area.

The MIC2169B senses current across the high-side N-Channel MOSFET, eliminating the need for an expensive and lossy current-sense resistor. Current-limit accuracy is maintained by a positive temperature coefficient that tracks the increasing $R_{DS(ON)}$ of the external MOSFET. Further cost and space are saved by the internal in-rush current-limiting digital soft-start. The MIC2169B is identical to the MIC2169A with the exception that the MIC2169B supports pre-bias loads and has a lower impedance gate-drive circuit. Internal pre-bias circuit prevents output voltage drooping and excessive reverse inductor current when powering up with a pre-bias voltage at the output.

The MIC2169B is available in a 10-pin MSOP and a thermally-capable 10-pin ePad MSOP package, with a wide junction operating range of -40°C to $+125^{\circ}\text{C}$.

All support documentation can be found on Micrel's web site at www.micrel.com.

Features

- 3V to 14.5V input voltage range
- Adjustable output voltage down to 0.8V
- 500kHz PWM operation
- Up to 95% efficiency
- Output Pre-biased Protection
- Build-in 2.2Ω drivers to drive two n-channel MOSFETs
- Adaptive gate drive increases efficiency
- Simple, externally-compensated voltage-mode PWM control
- Short minimum ON time of 30ns allowing very-low duty cycle
- Fast transient response
- Adjustable current limit senses high-side N-Channel MOSFET current
- Hiccup mode short-circuit protection
- No external current-sense resistor
- Internal soft-start current source
- Dual function COMP and EN pin allows low-power shutdown
- Available in small-size 10-pin MSOP and 10-pin MSOP ePad packages

Applications

- Point-of-load DC/DC conversion
- High-Current Power Supplies
- Telecom/Datacom and Networking Power Supplies
- Servers and Workstations
- Graphic cards and other PC Peripherals
- Set-top boxes
- LCD power supplies

Typical Application

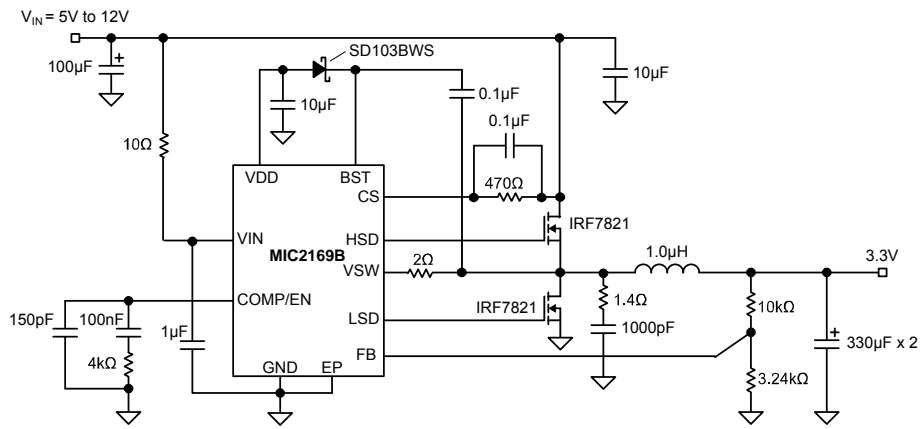

MIC2169B Adjustable Output 500kHz Converter

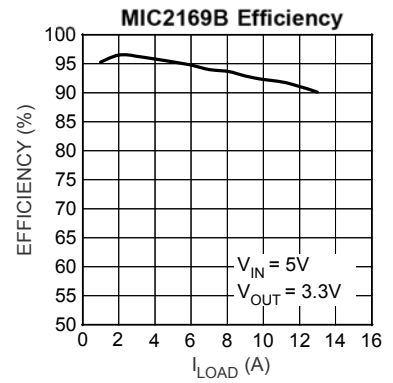

Ordering Information

Part Number	Frequency	Junction Temperature Range ⁽¹⁾	Package	Lead Finish
MIC2169BYMME	500kHz	-40° to +125°C	10-Lead ePad MSOP	Pb-Free
MIC2169BYMM	500kHz	-40° to +125°C	10-Lead MSOP	Pb-Free

Pin Configuration

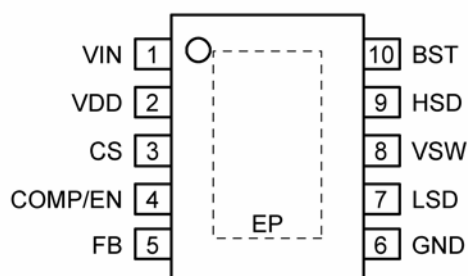

10-Pin ePad MSOP (MME)

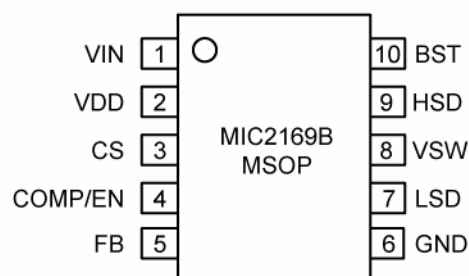

10-Pin MSOP

Pin Description

Pin Number	Pin Name	Pin Function
1	VIN	Supply Voltage (Input): +3V to +14.5V.
2	VDD	5V Internal Linear Regulator (Output): V _{DD} is the external MOSFET gate-drive supply voltage and an internal supply bus for the IC. When V _{IN} is <5V, short VDD to the input supply through a 10Ω resistor.
3	CS	Current Sense (Input): Current-limit comparator noninverting input. The current limit is sensed across the MOSFET during the ON time. The current can be set by the resistor in series with the CS pin.
4	COMP/EN	Compensation / Enable (Input): Dual function pin. Pin for external compensation. If this pin is pulled below 0.25V, with the reference fully up the device shuts down (50μA typical current draw).
5	FB	Feedback (Input): Input to error amplifier. Regulates error amplifier to 0.8V.
6	GND	Ground (Return).
7	LSD	Low-Side Drive (Output): High-current driver output for external synchronous MOSFET.
8	VSW	Switch (Return): High-side MOSFET driver return.
9	HSD	High-Side Drive (Output): High-current output-driver for the high-side MOSFET. When V _{IN} is between 3.0V to 5V, 2.5V threshold MOSFETs should be used. At V _{IN} > 5V, 4.5V threshold MOSFETs should be used.
10	BST	Boost (Input): Provides the drive voltage for the high-side MOSFET driver. The gate-drive voltage is higher than the source voltage by V _{DD} minus a diode drop.
ePad	EP	Connect to Ground.

Absolute Maximum Ratings⁽¹⁾

Supply Voltage (V_{IN}).....	-0.3V to 15.5V
Booststrapped Voltage (V_{BST})	-0.3V to $V_{IN} + 6V$
VSW	-0.3V to 15.5V
CS	15.25V
LSD,FB.....	-0.3V to 6V
Storage Temperature (T_S).....	-65°C to +150°C
Peak Reflow Temperature (10 to 20 sec)	+260°C
ESD (HBM) ⁽³⁾	2kV
ESD (MM).....	200V

Operating Ratings⁽²⁾

Supply Voltage (V_{IN}).....	+3V to +14.5V
Ambient Temperature (T_A)	-40°C to +85°C
Junction Temperature (T_J)	-40°C to +125°C
Junction Thermal Resistance	
ePad MSOP (θ_{JA}).....	76.7°C/W
ePad MSOP (θ_{JC})	9.6°C/W
MSOP (θ_{JA})	130°C/W
MSOP (θ_{JC}).....	42.6°C/W
Output Voltage Range.....	0.8V to $V_{IN} \times D_{MAX}$

Electrical Characteristics⁽⁴⁾

$T_J = 25^\circ\text{C}$, $V_{IN} = 5\text{V}$; **Bold** values indicate $-40^\circ\text{C} \leq T_J \leq +125^\circ\text{C}$; unless otherwise specified.

Parameter	Condition	Min	Typ	Max	Units
Feedback Voltage Reference	($\pm 1\%$)	0.792	0.8	0.808	V
Feedback Voltage Reference	($\pm 2\%$ over temp)	0.784	0.8	0.816	V
Feedback Bias Current			150	350	nA
Output Voltage Line Regulation			0.03		% / V
Output Voltage Load Regulation			0.5		%
Output Voltage Total Regulation	$3\text{V} \leq V_{IN} \leq 14.5\text{V}$; $1\text{A} \leq I_{OUT} \leq 10\text{A}$; ($V_{OUT} = 2.5\text{V}$) ⁽⁴⁾		0.6	1.5	%
Oscillator Section					
Oscillator Frequency		450	500	550	kHz
Maximum Duty Cycle		92			%
Minimum On-Time ⁽⁵⁾			30	60	ns
Input and V_{DD} Supply					
PWM Mode Supply Current	$V_{CS} = V_{IN} - 0.25\text{V}$; $V_{FB} = 0.7\text{V}$ (output switching but excluding external MOSFET gate current.)		1.5	3	mA
Shutdown Quiescent Current	$V_{COMP}/EN = 0\text{V}$		50	150	μA
V_{COMP} Shutdown Threshold		0.1	0.25	0.35	V
V_{COMP} Shutdown Blanking Period	$C_{COMP} = 100\text{nF}$		675		μs
Digital Supply Voltage (V_{DD})	$V_{IN} \geq 6\text{V}$	4.7	5	5.3	V

Electrical Characteristics⁽⁴⁾ (continued)

$T_J = 25^\circ\text{C}$, $V_{IN} = 5\text{V}$; **Bold** values indicate $-40^\circ\text{C} \leq T_J \leq +125^\circ\text{C}$; unless otherwise specified.

Parameter	Condition	Min	Typ	Max	Units
Error Amplifier					
DC Gain ⁽⁵⁾			70		dB
Transconductance			1.1		$\text{m}\Omega^{-1}$
Soft-Start					
Soft-Start Current	After time out of internal timer. $V_{\text{COMP}} = 0.8\text{V}$	4	8.5	13	μA
Current Sense					
CS Over Current Trip Point	$V_{\text{CS}} = V_{\text{IN}} - 0.25\text{V}$	160	200	240	μA
Temperature Coefficient			1800		ppm°C
Gate Drivers					
Rise/Fall Time	Into 3000pF at $V_{\text{IN}} > 5\text{V}$		15		ns
Output Driver Impedance	Source, $V_{\text{IN}} = 4.5\text{V}$		2.2	3	Ω
	Sink, $V_{\text{IN}} = 4.5\text{V}$		1.3	3	Ω
	Source, $V_{\text{IN}} = 3\text{V}$		2.7	4	Ω
	Sink, $V_{\text{IN}} = 3\text{V}$		1.7	4	Ω
Driver Non-Overlap Time ⁽⁵⁾			50		ns

Notes:

1. Absolute maximum ratings indicate limits beyond which damage to the component may occur. Electrical specifications do not apply when operating the device outside of its operating ratings. The maximum allowable power dissipation is a function of the maximum junction temperature, $T_{J(\text{max})}$, the junction-to-ambient thermal resistance, θ_{JA} , and the ambient temperature, T_A . The maximum allowable power dissipation will result in excessive die temperature.
2. The device is not guaranteed to function outside its operating rating.
3. Devices are ESD sensitive, handling precautions required.
4. Specification for packaged product only.
5. Guaranteed by design.

Typical Characteristics

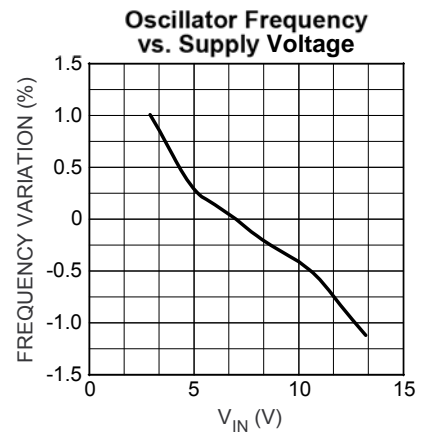
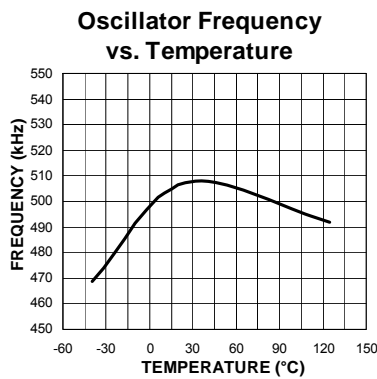
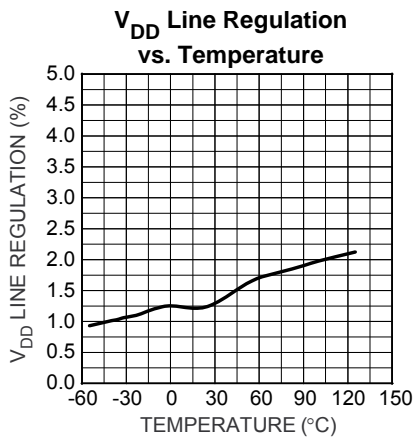
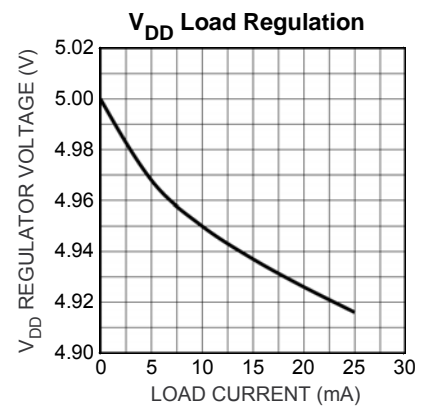
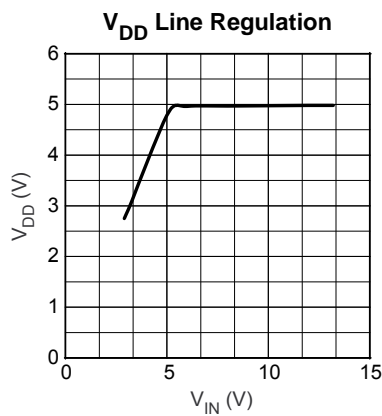
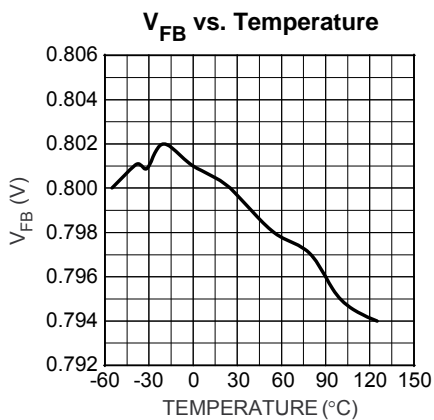
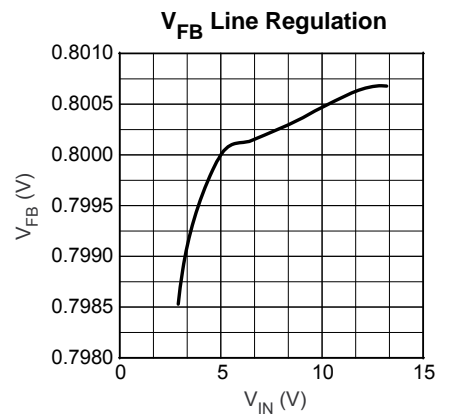
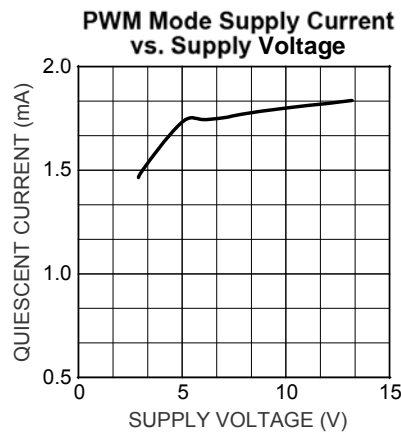
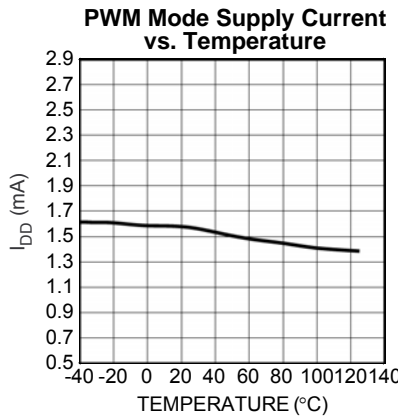

Typical Characteristics (continued)

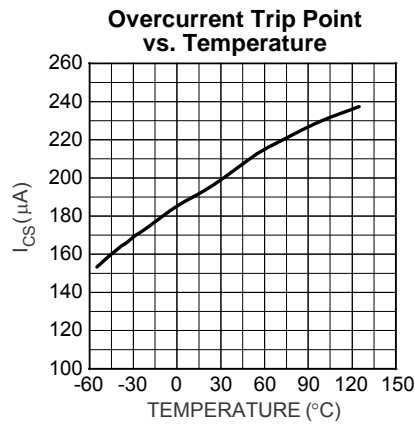

Functional Diagram

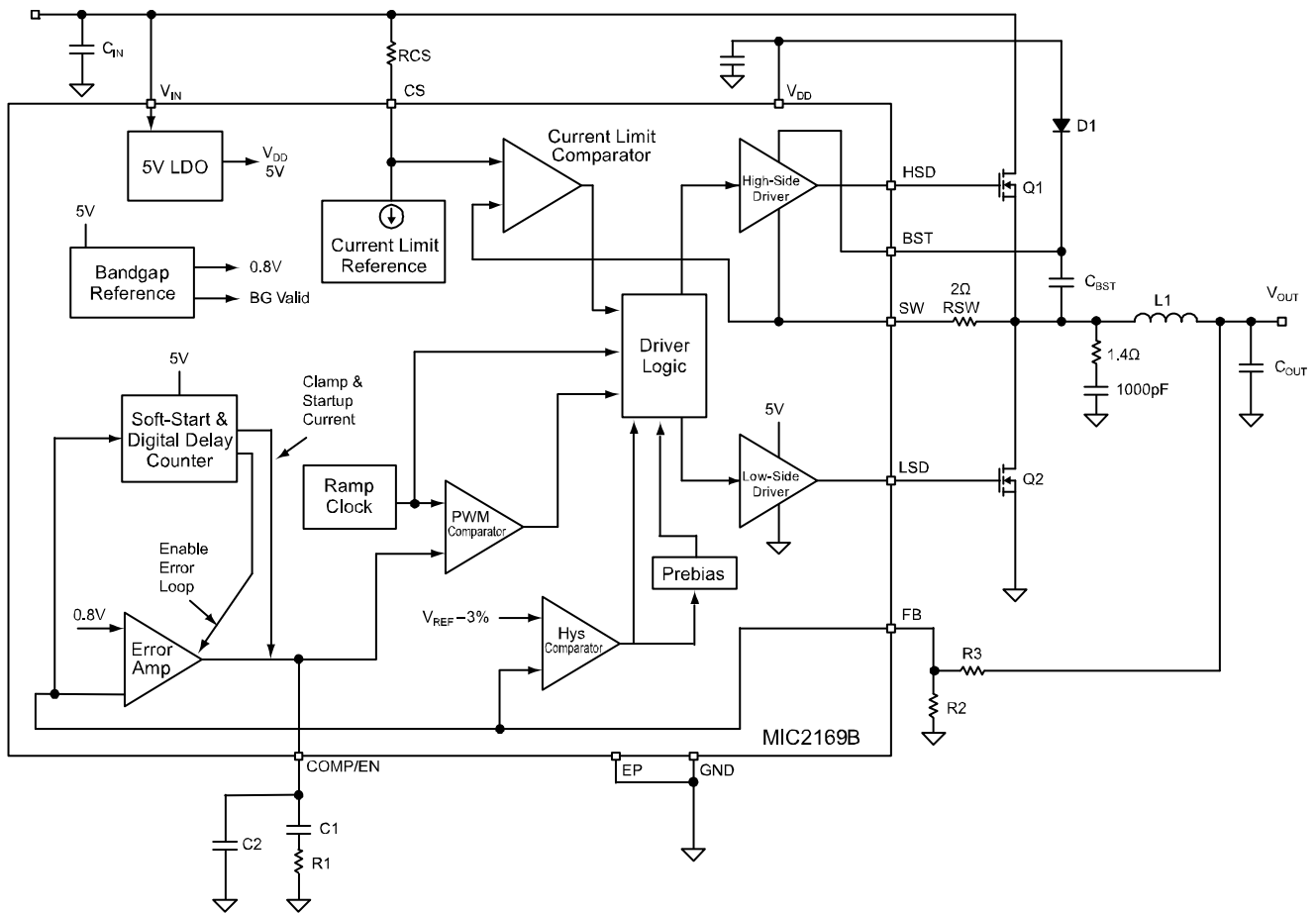

MIC2169B Block Diagram

Functional Description

The MIC2169B is a voltage-mode, synchronous step-down switching regulator controller designed for high power. Current limit is implemented without the use of an external sense resistor. It includes an internal soft-start function which reduces the power supply input surge current at start-up by controlling the output voltage rise time, a PWM generator, a reference voltage, two MOSFET drivers, and short-circuit current limiting circuitry to form a complete 500kHz switching regulator. MIC2169B is identical to the MIC2169A except it supports pre-bias loads and has a lower impedance gate-drive circuit.

Theory of Operation

The MIC2169B is a voltage mode step-down regulator. The figure above illustrates the block diagram for the voltage control loop. The output voltage variation due to load or line changes will be sensed by the inverting input of the transconductance error amplifier via the feedback resistors R3, and R2 and compared to a reference voltage at the non-inverting input. This will cause a small change in the DC voltage level at the output of the error amplifier which is the input to the PWM comparator. The other input to the comparator is a 0.95V to 1.45V triangular waveform. The comparator generates a rectangular waveform whose width t_{ON} is equal to the time from the start of the clock cycle t_0 until t_1 , the time the triangle crosses the output waveform of the error amplifier. To illustrate the control loop, let us assume the output voltage drops due to sudden load turn-on, this would cause the inverting input of the error amplifier, which is divided down version of V_{OUT} , to be slightly less than the reference voltage, causing the output voltage of the error amplifier to go high. This will cause the PWM comparator to increase t_{ON} time of the top side MOSFET, causing the output voltage to go up and bringing V_{OUT} back in regulation.

Soft-Start

The COMP/EN pin on the MIC2169B is used for the following three functions:

1. Disables the part by grounding this pin
2. External compensation to stabilize the voltage control loop
3. Soft-start

For better understanding of the soft-start feature, assume $V_{IN} = 12V$, and the MIC2169B is allowed to power-up by un-grounding the COMP/EN pin. The COMP pin has an internal $8.5\mu A$ current source that charges the external compensation capacitor. As soon as this voltage rises to 250mV ($t = Cap_COMP \times 0.25V/8.5\mu A$) and V_{IN} crosses the 2.6V UVLO threshold, the MIC2169B allows the internal V_{DD} linear regulator to

power up, and the chip's internal oscillator starts switching. At this point in time, the COMP pin current source increases to $40\mu A$ and an internal 12-bit counter starts counting which takes approximately 2ms to complete. During counting, the COMP voltage is clamped at 0.65V. After this counting cycle the COMP current source is reduced to $8.5\mu A$ and the COMP pin voltage rises from 0.65V to 0.95V, the bottom edge of the saw-tooth oscillator. This is the beginning of 0% duty cycle and it increases slowly causing the output voltage to rise slowly. The MIC2169B has one hysteretic comparator whose output is asserted high when V_{OUT} is within -3% of steady state. When the output voltage reaches 97% of programmed output voltage then the g_m error amplifier is enabled along with the hysteretic comparator output is asserted high. This point onwards, the voltage control loop (g_m error amplifier) is fully in control and will regulate the output voltage.

Soft-start time can be calculated approximately by adding the following four time frames:

$$t1 = Cap_COMP \times 0.25V/8.5\mu A$$

$$t2 = 12 \text{ bit counter, approx } 2ms$$

$$t3 = Cap_COMP \times 0.3V/8.5\mu A$$

$$t4 = \left(\frac{V_{OUT}}{V_{IN}} \right) \times 0.5 \times \frac{Cap_COMP}{8.5\mu A}$$

$$\begin{aligned} \text{Soft-Start Time}(Cap_COMP=100nF) &= t1 + t2 \\ &+ t3 + t4 = 2.9ms + 2ms + 3.5ms + 1.6ms = \\ &10ms \end{aligned}$$

Current Limit

The MIC2169B uses the $R_{DS(ON)}$ of the top power MOSFET to measure output current. Since it uses the drain to source resistance of the power MOSFET, it is not very accurate. This scheme is adequate to protect the power supply and external components during a fault condition by cutting back the time the top MOSFET is on if the feedback voltage is greater than 0.67V. In case of a hard short when feedback voltage is less than 0.67V, the MIC2169B discharges the COMP capacitor to 0.65V, resets the digital counter and automatically shuts off the top gate drive, the g_m error amplifier is completely disabled, the -3% hysteretic comparators is asserted low, and the soft-start cycles restart from $t2$ to $t4$. This mode of operation is called the "hiccup mode" and its purpose is to protect the down stream load in case of a hard short. The circuit in Figure 1 illustrates the MIC2169B current limiting circuit.

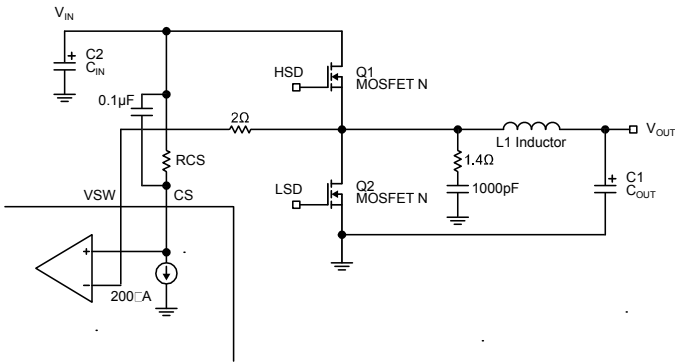

Figure 1. The MIC2169B Current Limiting Circuit

The current limiting resistor R_{CS} is calculated by the following equation:

$$R_{CS} = \frac{R_{DS(ON)Q1} \times I_L}{200\mu A}$$

where:

$$I_L = I_{LOAD} + \frac{\text{Inductor Ripple Current}}{2}$$

$$\text{Inductor Ripple Current} = V_{OUT} \times \frac{(V_{IN} - V_{OUT})}{V_{IN} \times F_S \times L}$$

$F_S = 500\text{kHz}$

$200\mu A$ is the internal sink current to program the MIC2169B current limit.

The MOSFET $R_{DS(ON)}$ varies 30% to 40% with temperature; therefore, it is recommended to add a 50% margin to the load current (I_{LOAD}) in the above equation to avoid false current limiting due to increased MOSFET junction temperature rise. It is also recommended to connect R_{CS} resistor directly to the drain of the top MOSFET Q1, and the R_{SW} resistor to the source of Q1 to accurately sense the MOSFET's $R_{DS(ON)}$. To make the MIC2169B insensitive to board layout and noise generated by the switch node, a 1.4Ω resistor and a 1000pF capacitor is recommended between the switch node and GND.

Internal V_{DD} Supply

The MIC2169B controller internally generates V_{DD} for self biasing and to provide power to the gate drives. This V_{DD} supply is generated through a low-dropout regulator and generates 5V from V_{IN} supply greater than 5V. For supply voltage less than 5V, the V_{DD} linear regulator is approximately 200mV in dropout. Therefore, it is recommended to short the V_{DD} supply to the input supply through a 10Ω resistor for input supplies between 3.0V to 5V.

MOSFET Gate Drive

The MIC2169B high-side drive circuit is designed to switch an N-Channel MOSFET. The Functional Block Diagram shows a bootstrap circuit, consisting of D1 and C_{BST} , supplies energy to the high-side drive circuit. Capacitor C_{BST} is charged while the low-side MOSFET is on and the voltage on the VSW pin is approximately 0V. When the high-side MOSFET driver is turned on, energy from C_{BST} is used to turn the MOSFET on. As the MOSFET turns on, the voltage on the VSW pin increases to approximately V_{IN} . Diode D1 is reversed biased and C_{BST} floats high while continuing to keep the high-side MOSFET on. When the low-side switch is turned back on, C_{BST} is recharged through D1. The drive voltage is derived from the internal 5V V_{DD} bias supply. The nominal low-side gate drive voltage is 5V and the nominal high-side gate drive voltage is approximately 4.5V due the voltage drop across D1. An approximate 50ns delay between the high-side and low-side driver transitions is used to prevent current from simultaneously flowing unimpeded through both MOSFETs (shoot-through).

Adaptive gate drive is implemented on the high-side (off) to low-side (on) driver transition to reduce losses in the flywheel diode and to prevent shoot-through. This is operated by detecting the VSW pin; once this pin is detected to reach 1.5V, the high-side MOSFET can be assumed to be off and the low side driver is enabled.

Total Power Dissipation and Thermal Considerations

Total power dissipation in the MIC2169B equals the power dissipation caused by driving the external MOSFETs plus the quiescent supply current:

$$P_{diss_{TOTAL}} = P_{diss_{SUPPLY}} + P_{diss_{DRIVE}}$$

where:

$$P_{diss_{SUPPLY}} = V_{DD} \times I_{DD}$$

I_{DD} is shown in the "PWM Mode Supply Current" graph in the Typical Characteristics section of the specification.

$P_{diss_{DRIVE}}$ calculations are shown in the Applications section of the specification.

The die temperature may be calculated once the total power dissipation is known:

$$T_J = T_A + P_{diss_{TOTAL}} \times \theta_{JA}$$

where:

T_A is the maximum ambient temperature ($^{\circ}\text{C}$)

T_J is the junction temperature ($^{\circ}\text{C}$)

$P_{diss_{TOTAL}}$ is the power dissipation of the MIC2169B (W)

θ_{JC} is the thermal resistance from junction-to-ambient air ($^{\circ}\text{C}/\text{W}$)

The following graphs are used to determine the maximum gate charge that can be driven with respect to supply voltage and ambient temperature. Figure 2 shows the power dissipation in the driver for different values of gate charge.

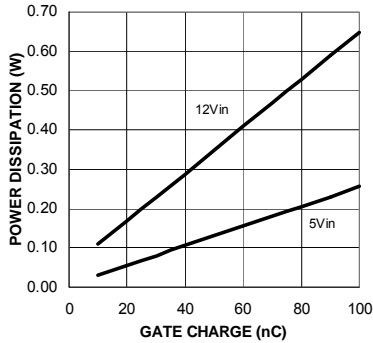

Figure 2. Power Dissipation vs. Total Gate Charge

Figure 3 shows the maximum allowable power dissipation vs ambient temperature. For a given total gate charge, the maximum operating ambient temperature can be found by using the two graphs.

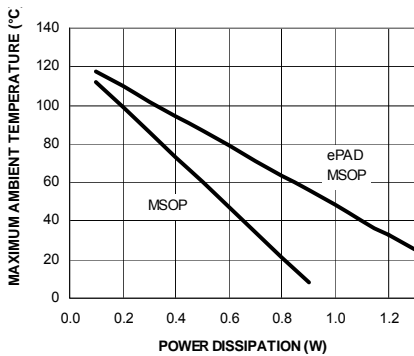

Figure 3. Maximum Ambient Temperature vs. Power Dissipation

Figures 4 and 5 show the increase in junction and case temperature for a given power dissipation.

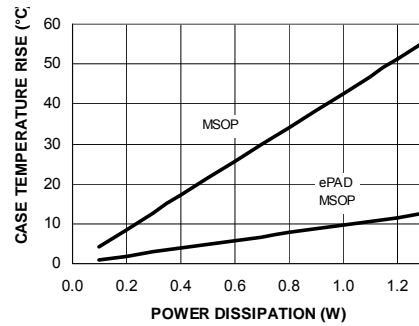

Figure 4. Case Temperature Rise vs. Power Dissipation

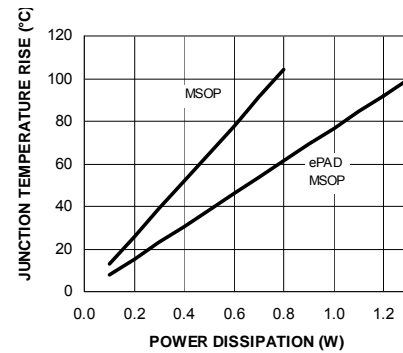

Figure 5. Junction Temperature Rise vs. Power Dissipation

Application Information

MOSFET Selection

The MIC2169B controller works from input voltages of 3V to 14.5V and has an internal 5V regulator to provide power to turn the external N-Channel power MOSFETs for high- and low-side switches. For applications where $V_{IN} < 5V$, the internal V_{DD} regulator operates in dropout mode, and it is necessary that the power MOSFETs used are sub-logic level and are in full conduction mode for V_{GS} of 2.5V. For applications when $V_{IN} > 5V$; logic-level MOSFETs, whose operation is specified at $V_{GS} = 4.5V$ must be used. For the lower (<5V) applications, the V_{DD} supply can be connected directly to V_{IN} to help increase the driver voltage to the MOSFET.

It is important to note the on-resistance of a MOSFET increases with increasing temperature. A 75°C rise in junction temperature will increase the channel resistance of the MOSFET by 50% to 75% of the resistance specified at 25°C. This change in resistance must be accounted for when calculating MOSFET power dissipation and in calculating the value of current-sense (CS) resistor. Total gate charge is the charge required to turn the MOSFET on and off under specified operating conditions (V_{DS} and V_{GS}). The gate charge is supplied by the MIC2169B gate-drive circuit. At 500kHz switching frequency and above, the gate charge can be a significant source of power dissipation in the MIC2169B. At low output load, this power dissipation is noticeable as a reduction in efficiency. The average current required to drive the high-side MOSFET is:

$$I_{G[\text{high-side}]}(\text{avg}) = Q_G \times f_S$$

where:

$I_{G[\text{high-side}]}(\text{avg})$ = average high-side MOSFET gate current.

Q_G = total gate charge for the high-side MOSFET taken from manufacturer's data sheet for $V_{GS} = 5V$.

The low-side MOSFET is turned on and off at $V_{DS} = 0$ because the freewheeling diode is conducting during this time. The switching loss for the low-side MOSFET is usually negligible. Also, the gate-drive current for the low-side MOSFET is more accurately calculated using C_{ISS} at $V_{DS} = 0$ instead of gate charge.

For the low-side MOSFET:

$$I_{G[\text{low-side}]}(\text{avg}) = C_{ISS} \times V_{GS} \times f_S$$

Since the current from the gate drive comes from the input voltage, the power dissipated in the MIC2169B due to gate drive is:

$$P_{\text{GATEDRIVE}} = V_{IN} \times (I_{G[\text{high-side}]}(\text{avg}) + I_{G[\text{low-side}]}(\text{avg}))$$

A convenient figure of merit for switching MOSFETs is the on resistance times the total gate charge $R_{DS(\text{ON})} \times Q_G$. Lower numbers translate into higher efficiency. Low gate-charge logic-level MOSFETs are a good choice for use with the MIC2169B.

Parameters that are important to MOSFET switch selection are:

- Voltage rating
- On-resistance
- Total gate charge

The voltage ratings for the top and bottom MOSFET are essentially equal to the input voltage. A safety factor of 20% should be added to the $V_{DS(\text{max})}$ of the MOSFETs to account for voltage spikes due to circuit parasitics.

The power dissipated in the switching transistor is the sum of the conduction losses during the on-time ($P_{\text{CONDUCTION}}$) and the switching losses that occur during the period of time when the MOSFETs turn on and off (P_{AC}).

$$P_{\text{SW}} = P_{\text{CONDUCTION}} + P_{\text{AC}}$$

where:

$$P_{\text{CONDUCTION}} = I_{\text{SW}(\text{rms})}^2 \times R_{\text{SW}}$$

$$P_{\text{AC}} = P_{\text{AC}(\text{off})} + P_{\text{AC}(\text{on})}$$

R_{SW} = on-resistance of the MOSFET switch

$$D = \text{duty cycle} = \left(\frac{V_O}{V_{IN}} \right)$$

Making the assumption the turn-on and turn-off transition times are equal; the transition times can be approximated by:

$$t_T = \frac{C_{ISS} \times V_{GS} + C_{OSS} \times V_{IN}}{I_G}$$

where:

C_{ISS} and C_{OSS} are measured at $V_{DS} = 0$

I_G = gate-drive current (1.4A for the MIC2169B)

The total high-side MOSFET switching loss is:

$$P_{\text{AC}} = (V_{IN} + V_D) \times I_{PK} \times t_T \times f_S$$

where:

t_T = switching transition time (typically 20ns to 50ns)

V_D = freewheeling diode drop, typically 0.5V

f_S is the switching frequency, nominally 500kHz

The low-side MOSFET switching losses are negligible and can be ignored for these calculations.

Inductor Selection

Values for inductance, peak, and RMS currents are required to select the output inductor. The input and output voltages and the inductance value determine the peak-to-peak inductor ripple current. Generally, higher inductance values are used with higher input voltages. Larger peak-to-peak ripple currents will increase the power dissipation in the inductor and MOSFETs. Larger output ripple currents will also require more output capacitance to smooth out the larger ripple current. Smaller peak-to-peak ripple currents require a larger inductance value and therefore a larger and more expensive inductor. A good compromise between size, loss and cost is to set the inductor ripple current to be equal to 20% of the maximum output current. The inductance value is calculated by the equation below.

$$L = \frac{V_{OUT} \times (V_{IN(max)} - V_{OUT})}{V_{IN(max)} \times f_S \times 0.2 \times I_{OUT(max)}}$$

where:

f_S = switching frequency, 500kHz

0.2 = ratio of AC ripple current to DC output current

$V_{IN(max)}$ = maximum input voltage

The peak-to-peak inductor current (AC ripple current) is:

$$I_{PP} = \frac{V_{OUT} \times (V_{IN(max)} - V_{OUT})}{V_{IN(max)} \times f_S \times L}$$

The peak inductor current is equal to the average output current plus one half of the peak-to-peak inductor ripple current.

$$I_{PK} = I_{OUT(max)} + 0.5 \times I_{PP}$$

The RMS inductor current is used to calculate the $I^2 \times R$ losses in the inductor.

$$I_{INDUCTOR} = \sqrt{(I_{OUT_MAX})^2 + \frac{I_{PP}^2}{12}}$$

Maximizing efficiency requires the proper selection of core material and minimizing the winding resistance. The high frequency operation of the MIC2169B requires the use of ferrite materials for all but the most cost sensitive applications.

Lower cost iron powder cores may be used but the increase in core loss will reduce the efficiency of the power supply. This is especially noticeable at low output power. The winding resistance decreases efficiency at the higher output current levels. The winding resistance must be minimized although this usually comes at the expense of a larger inductor. The power dissipated in the inductor is equal to the sum of the core and copper losses. At higher output loads, the core losses are usually insignificant and can be ignored. At lower output

currents, the core losses can be a significant contributor. Core loss information is usually available from the magnetics vendor. Copper loss in the inductor is calculated by the equation below:

$$P_{INDUCTORCu} = I_{INDUCTOR(rms)}^2 \times R_{WINDING}$$

The resistance of the copper wire, $R_{WINDING}$, increases with temperature. The value of the winding resistance used should be at the operating temperature.

$$R_{WINDING(hot)} = R_{WINDING(20^\circ C)} \times (1 + 0.0042 \times (T_{HOT} - T_{20^\circ C}))$$

where:

T_{HOT} = temperature of the wire under operating load

$T_{20^\circ C}$ = ambient temperature

$R_{WINDING(20^\circ C)}$ = room temperature winding resistance (usually specified by the manufacturer)

Output Capacitor Selection

The output capacitor values are usually determined by the capacitors ESR (equivalent series resistance). Voltage and RMS current capability are two other important factors selecting the output capacitor. Recommended capacitors are tantalum, low-ESR aluminum electrolytics, and POSCAPS. The output capacitor's ESR is usually the main cause of output ripple. The output capacitor ESR also affects the overall voltage feedback loop from stability point of view. See "Feedback Loop Compensation" section for more information. The maximum value of ESR is calculated:

$$R_{ESR} \leq \frac{\Delta V_{OUT}}{I_{PP}}$$

where:

V_{OUT} = peak-to-peak output voltage ripple

I_{PP} = peak-to-peak inductor ripple current

The total output ripple is a combination of the ripple due to the output capacitors' ESR and the ripple due to the output capacitor. The total ripple is calculated below:

$$\Delta V_{OUT} = \sqrt{\left(\frac{I_{PP} \times (1-D)}{C_{OUT} \times f_S}\right)^2 + (I_{PP} \times R_{ESR})^2}$$

where:

D = duty cycle

C_{OUT} = output capacitance value

f_S = switching frequency

The voltage rating of capacitor should be twice the voltage for a tantalum and 20% greater for aluminum electrolytic.

The output capacitor RMS current is calculated below:

$$I_{C_{OUT(rms)}} = \frac{I_{PP}}{\sqrt{12}}$$

The power dissipated in the output capacitor is:

$$P_{DISS(C_{OUT})} = (I_{C_{OUT(rms)}})^2 \times R_{ESR(C_{OUT})}$$

Input Capacitor Selection

The input capacitor should be selected for ripple current rating and voltage rating. Tantalum input capacitors may fail when subjected to high inrush currents, caused by turning the input supply on. A tantalum input capacitor’s voltage rating should be at least 2 times the maximum input voltage to maximize reliability. Aluminum electrolytic, OS-CON, and multilayer polymer film capacitors can handle the higher inrush currents without voltage derating. The input voltage ripple will primarily depend on the input capacitor’s ESR. The peak input current is equal to the peak inductor current, so:

$$\Delta V_{IN} = I_{INDUCTOR(peak)} \times R_{ESR(C_{IN})}$$

The input capacitor must be rated for the input current ripple. The RMS value of input capacitor current is determined at the maximum output current. Assuming the peak-to-peak inductor ripple current is low:

$$I_{C_{IN(rms)}} \approx I_{OUT(max)} \times \sqrt{D \times (1-D)}$$

The power dissipated in the input capacitor is:

$$P_{DISS(C_{IN})} = (I_{C_{IN(rms)}})^2 \times R_{ESR(C_{IN})}$$

Voltage Setting Components

The MIC2169B requires two resistors to set the output voltage as shown in Figure 6.

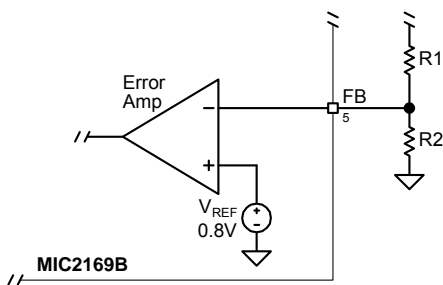

Figure 6. Voltage-Divider Configuration

The output voltage is determined by the equation:

$$V_O = V_{REF} \times \left(1 + \frac{R1}{R2}\right)$$

where

V_{REF} for the MIC2169B is typically 0.8V

A typical value of R1 can be between 3kΩ and 10kΩ. If R1 is too large, it may allow noise to be introduced into the voltage feedback loop. If R1 is too small, in value, it will decrease the efficiency of the power supply, especially at light loads. Once R1 is selected, R2 can be calculated using:

$$R2 = \frac{V_{REF} \times R1}{V_O - V_{REF}}$$

External Schottky Diode

An external freewheeling diode is used to keep the inductor current flow continuous while both MOSFETs are turned off. This dead time prevents current from flowing unimpeded through both MOSFETs and is typically 50ns. The diode conducts twice during each switching cycle. Although the average current through this diode is small, the diode must be able to handle the peak current.

$$I_{D(avg)} = I_{OUT} \times 2 \times 50ns \times f_s$$

The reverse voltage requirement of the diode is:

$$V_{DIODE(rm)} = V_{IN}$$

The power dissipated by the Schottky diode is:

$$P_{DIODE} = I_{D(avg)} \times V_F$$

where:

V_F = forward voltage at the peak diode current

The external Schottky diode, D1, is not necessary for circuit operation since the low-side MOSFET contains a parasitic body diode. The external diode will improve efficiency and decrease high frequency noise. If the MOSFET body diode is used, it must be rated to handle the peak and average current. The body diode has a relatively slow reverse recovery time and a relatively high forward voltage drop. The power lost in the diode is proportional to the forward voltage drop of the diode. As the high-side MOSFET starts to turn on, the body diode becomes a short circuit for the reverse recovery period, dissipating additional power. The diode recovery and the circuit inductance will cause ringing during the high-side MOSFET turn-on. An external Schottky diode conducts at a lower forward voltage preventing the body diode in the MOSFET from turning on. The lower forward voltage drop dissipates less power than the body diode. The lack of a reverse recovery mechanism in a Schottky diode causes less ringing and less power loss.

Depending on the circuit components and operating conditions, an external Schottky diode will give a ½% to 1% improvement in efficiency.

Feedback Loop Compensation

The MIC2169B controller comes with an internal transconductance error amplifier used for compensating the voltage feedback loop by placing a capacitor (C1) in series with a resistor (R1) and another capacitor C2 in parallel from the COMP pin to ground. See “Functional Block Diagram.”

Power Stage

The power stage of a voltage mode controller has an inductor, L1, with its winding resistance (DCR) connected to the output capacitor, C_{OUT}, with its electrical series resistance (ESR) as shown in Figure 7. The transfer function G(s), for such a system is:

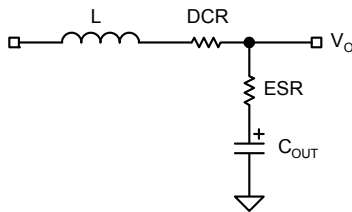

Figure 7. The Output LC Filter in a Voltage-Mode Buck Converter

$$G(s) = \left(\frac{(1 + ESR \times s \times C)}{DCR \times s \times C + s^2 \times L \times C + 1 + ESR \times s \times C} \right)$$

Plotting this transfer function with the following assumed values (L=1µH, DCR=0.009Ω, C_{OUT}=660µF, ESR=0.025Ω) gives lot of insight as to why one needs to compensate the loop by adding resistor and capacitors on the COMP pin. Figures 8 and 9 show the gain curve and phase curve for the above transfer function.

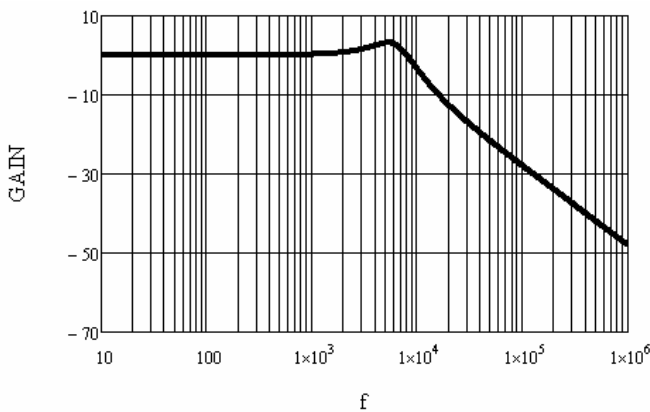

Figure 8. The Gain Curve for G(s)

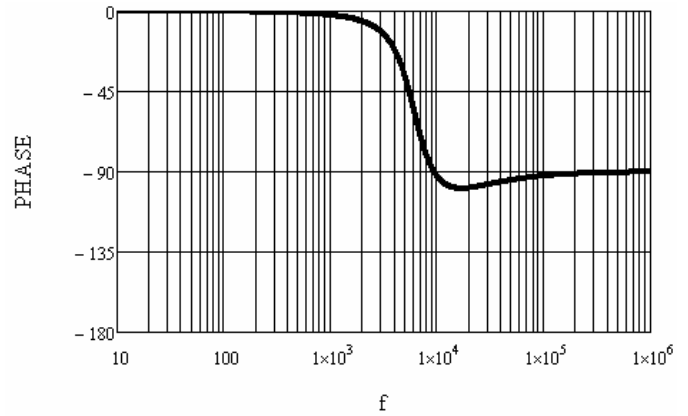

Figure 9. Phase Curve for G(s)

It can be seen from the transfer function G(s) and the gain curve that the output inductor and capacitor create a two pole system with a break frequency at:

$$f_{LC} = \frac{1}{2 \times \pi \times \sqrt{L \times C_{OUT}}}$$

Therefore, f_{LC} = 6.2kHz

By looking at the phase curve, it can be seen that the output capacitor ESR (0.025Ω) cancels one of the two poles (LC_{OUT}) system by introducing a zero at:

$$f_{ZERO} = \frac{1}{2 \times \pi \times ESR \times C_{OUT}}$$

Therefore, F_{ZERO} = 9.6kHz.

From the point of view of compensating the voltage loop, it is recommended to use higher ESR output capacitors since they provide a 90° phase gain in the power path. For comparison purposes, Figure 10, shows the same phase curve with an ESR value of 0.002Ω.

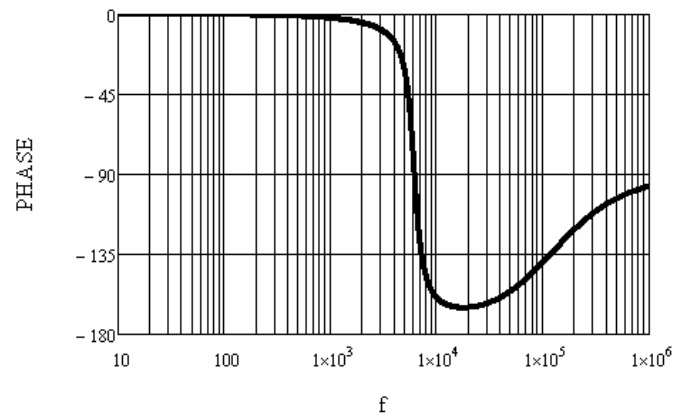

Figure 10. The Phase Curve with ESR = 0.002Ω

It can be seen from Figure 9 that at 50kHz, the phase is approximately -90° versus Figure 10 where the number is -150° . This means that the transconductance error amplifier has to provide a phase boost of about 45° to achieve a closed loop phase margin of 45° at a crossover frequency of 50kHz for Figure 9, versus 105° for Figure 10. The simple RC and C2 compensation scheme allows a maximum error amplifier phase boost of about 90° . Therefore, it is easier to stabilize the MIC2169B voltage control loop by using high-ESR value output capacitors.

g_m Error Amplifier

It is undesirable to have high error amplifier gain at high frequencies because high frequency noise spikes would be picked up and transmitted at large amplitude to the output, thus, gain should be permitted to fall off at high frequencies. At low frequency, it is desired to have high open-loop gain to attenuate the power line ripple. Thus, the error amplifier gain should be allowed to increase rapidly at low frequencies.

The transfer function with R1, C1, and C2 for the internal g_m error amplifier can be approximated by the following equation:

$$\text{Error Amplifier}(z) = g_m \times \left[\frac{1 + s \times R1 \times C1}{s \times (C1 + C2) \times \left(1 + s \times R1 \times \frac{C1 \times C2}{C1 + C2} \right)} \right]$$

The above equation can be simplified by assuming $C2 \ll C1$,

$$\text{Error Amplifier}(z) = g_m \times \left[\frac{1 + s \times R1 \times C1}{s \times C1 \times (1 + s \times R1 \times C2)} \right]$$

From the above transfer function, one can see that R1 and C1 introduce a zero and R1 and C2 a pole at the following frequencies:

$$F_{ZERO} = 1/2 \pi \times R1 \times C1$$

$$F_{POLE} = 1/2 \pi \times C2 \times R1$$

$$F_{POLE@origin} = 1/2 \pi \times C1$$

Figures 11 and 12 show the gain and phase curves for the above transfer function with R1 = 4.02k, C1 = 100nF, C2 = 150pF, and g_m = 1.1mΩ⁻¹.

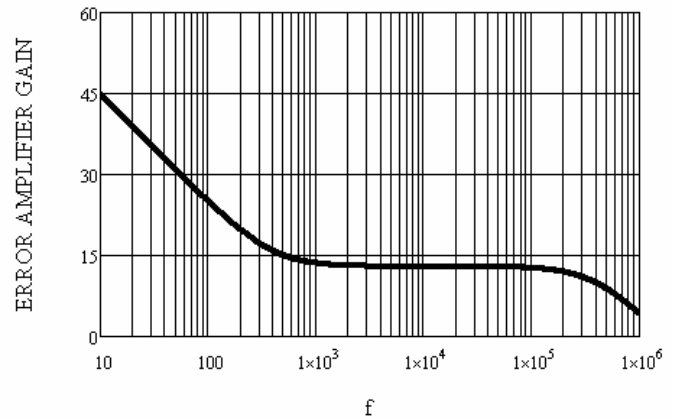

Figure 11. Error Amplifier Gain Curve

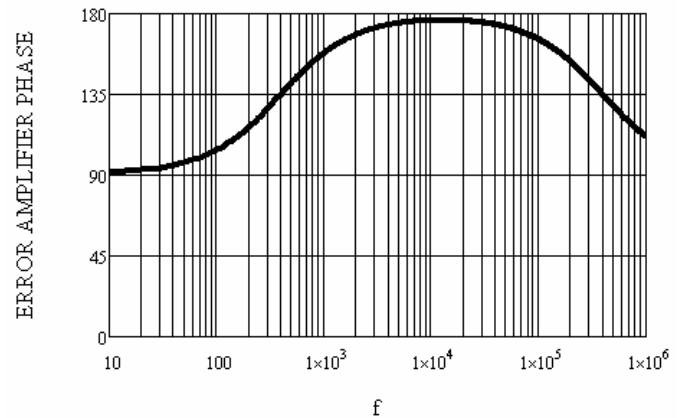

Figure 12. Error Amplifier Phase Curve

Total Open-Loop Response

The open-loop response for the MIC2169B controller is easily obtained by adding the power path and the error amplifier gains together, since they already are in Log scale. It is desirable to have the gain curve intersect zero dB at tens of kilohertz, this is commonly called crossover frequency; the phase margin at crossover frequency should be at least 45° . Phase margins of 30° or less cause the power supply to have substantial ringing when subjected to transients, and have little tolerance for component or environmental variations.

Figures 13 and 14 show the open-loop gain and phase margin for the 5V input and 1.8V output application, and it can be seen from Figure 13 that the gain curve intersects the 0dB at approximately 50kHz, and from Figure 14 that at 50kHz, the phase shows approximately 74° of margin.

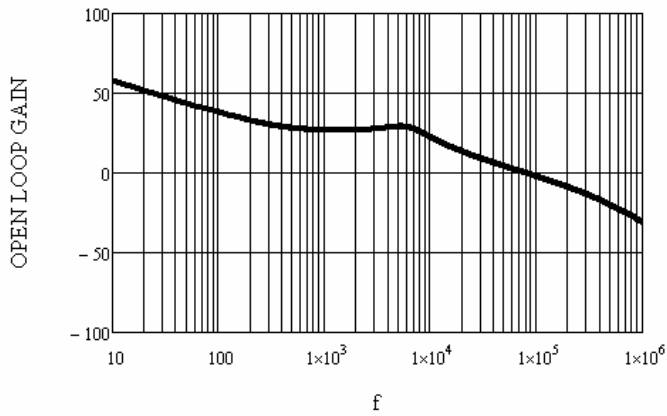

Figure 13. Open-Loop Gain Margin

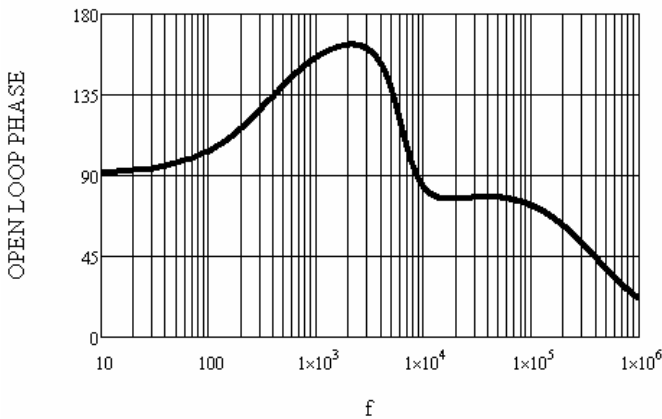

Figure 14. Open-Loop Phase Margin

Pre-Biased Loads

The MIC2169B supports pre-biased loads. Some applications have a pre-existing voltage on the output. This pre-existing or pre-biased load is generated by an external supply (other than the MIC2169B). During startup without pre-bias support, MIC2169A will pull the output voltage to ground through the inductor and low side FET (see Figure 15).

The MIC2169B prevents the current sinking of any pre-existing voltage source at the output (see Figure 16). It does this by keeping the low-side FET off during the soft start period. In some applications this pre-bias current sink is not a problem, and the MIC2169A may be used. In some applications the pre-bias current sink may cause a problem, and the MIC2169B should be used. The MIC2169B can support up to 90% of a pre-bias condition (up to 90% of the final regulated output voltage) see Figure 17.

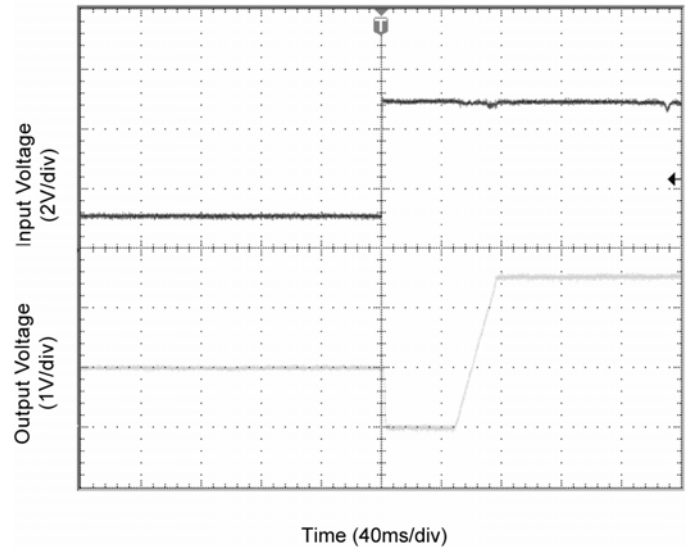

Figure 15. MIC2169A Startup without Pre-Bias Support

Figure 15 shows MIC2169B startup with a pre-bias of 1V on the output, in which the pre-existing output voltage discharges during soft start.

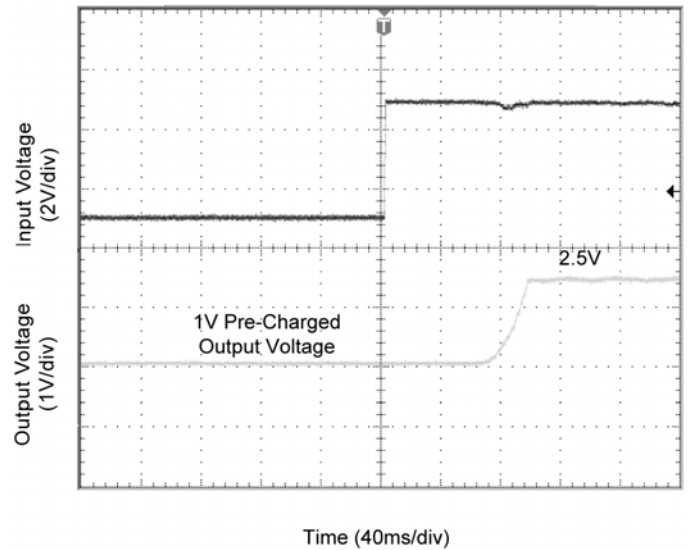
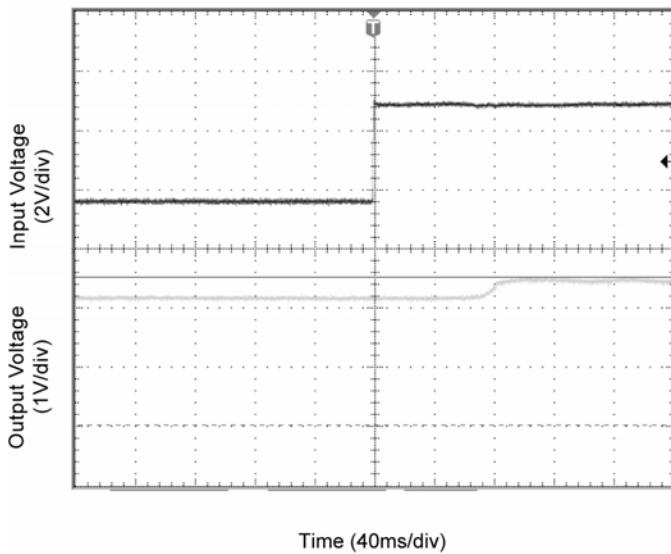

Figure 16. MIC2169B Startup with Pre-Bias Support

Figure 16 shows MIC2169B startup with a pre-bias of 1V on the output, in which the pre-existing output voltage has no discharge.



**Figure 17. MIC2169B Startup with Pre-Bias Support,
Pre-Bias At 90% of V_{OUT_FINAL}**

Figure 17 shows MIC2169B startup with a pre-bias of 2.2V on the output (90% of V_{OUT}) without the pre-existing output voltage discharge.

Design and PCB Layout Guideline

WARNING!!! TO MINIMIZE EMI AND OUTPUT NOISE, FOLLOW THESE LAYOUT RECOMMENDATIONS:

PCB Layout is critical to achieve reliable, stable and efficient performance. A ground plane is required to control EMI and minimize the inductance in power, signal and return paths.

The following guidelines should be followed to insure proper operation of the MIC2169B converter.

IC

- Place the IC and MOSFETs close to the point of load (POL).
- Use fat traces to route the input and output power lines.
- Signal and power grounds should be kept separate and connected at only one location.

Input Capacitor

- Place the V_{IN} input capacitor next.
- Place the V_{IN} input capacitors on the same side of the board and as close to the MOSFETs as possible.

- Keep both the V_{IN} and power GND connections short.
- Place several vias to the ground plane close to the V_{IN} input capacitor ground terminal.
- Use either X7R or X5R dielectric input capacitors. Do not use Y5V or Z5U type capacitors.
- Do not replace the ceramic input capacitor with any other type of capacitor. Any type of capacitor can be placed in parallel with the input capacitor.
- If a Tantalum input capacitor is placed in parallel with the input capacitor, it must be recommended for switching regulator applications and the operating voltage must be derated by 50%.
- In “Hot-Plug” applications, a Tantalum or Electrolytic bypass capacitor must be used to limit the over-voltage spike seen on the input supply with power is suddenly applied.
- An additional Tantalum or Electrolytic bypass input capacitor of 22 μ F or higher is required at the input power connection.
- Use a 5 Ω resistor from the input supply to the V_{DD} pin on the MIC2169B. Also, place a 1 μ F ceramic capacitor from this pin to GND, preferably not through a via. The capacitor must be located right at the IC. The V_{dd} terminal is very noise sensitive and placement of the capacitor is very critical. Connections must be made with wide trace.

Inductor

- Keep the inductor connection to the switch node (SW) short.
- Do not route any digital lines underneath or close to the inductor.
- Keep the switch node (SW) away from the feedback (FB) pin.
- To minimize noise, place a ground plane underneath the inductor.

Output Capacitor

- Use a wide trace to connect the output capacitor ground terminal to the input capacitor ground terminal.
- Phase margin will change as the output capacitor value and ESR changes. Contact the factory if the output capacitor is different from what is shown in the BOM.
- The feedback trace should be separate from the power trace and connected as close as possible to the output capacitor. Sensing a long high-current load trace can degrade the DC load regulation.

MOSFETs

- Low gate charge MOSFETs should be used to maximize efficiency, such as Si4800, Si4804BDY, IRF7821, IRF8910, FDS6680A and FDS6912A, etc.

RC Snubber

- Add a RC snubber of 1.4Ω resistor and a 1000pF capacitor from the switch node to ground pin. Place the snubber on the same side of the board and as close to the MOSFETs as possible. See page 8, Current Limiting section for more detail.

Schottky Diode (Optional)

- Place the Schottky diode on the same side of the board as the MOSFETs and V_{IN} input capacitor.
- The connection from the Schottky diode's Anode to the input capacitors ground terminal must be as short as possible.
- The diode's Cathode connection to the switch node (SW) must be keep as short as possible.

Others

- Connect the current limiting (R2) resistor directly to the drain of top MOSFET Q3.
- The feedback resistors R3 and R4/R5/R6 should be placed close to the FB pin. The top side of R3 should connect directly to the output node. Run this trace away from the switch node (junction of Q3, Q2, and L1). The bottom side of R3 should connect to the GND pin on the MIC2169B.
- The compensation resistor and capacitors should be placed right next to the COMP pin and the other side should connect directly to the GND pin on the MIC2169B rather than going to the plane.
- Add a place holder for a gate resistor on the top MOSFET gate drive. Do not use a resistor in series with the low-side MOSFET gate.

Evaluation Board Schematics

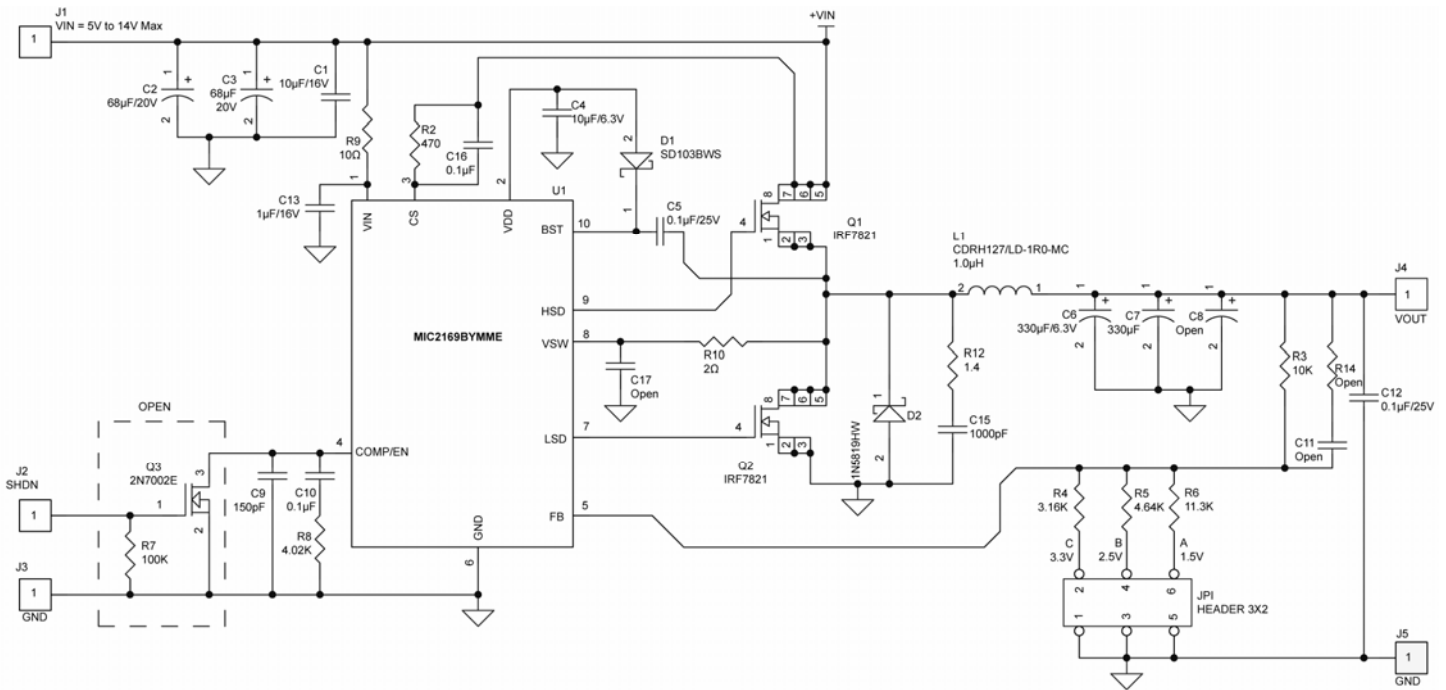

MIC2169B Evaluation Board Schematic

Bill of Materials

Item	Part Number	Manufacturer	Description	Qty.
U1	MIC2169B-YMME	Micrel, Inc.	Buck Controller	1
Q1, Q2	IRF7821-TR SI4174DY	IR Vishay	30V, N-Channel HEXFET, Power MOSFET	2 0
Q3	2N7002E	On Semiconductor	60V, N-Channel MOSFET	0
D1	SD103BWS	Vishay	30V, Schottky Diode	1
D2	1N5819HW SL04 CMMSH1-40	Diodes, Inc. Vishay Central Semi	40V, Schottky Diode	1 0 0
L1	CDRH127LDNP-1R0NC HC5-1R0 SER1360-1R0	Sumida Cooper Electronic Coilcraft	1.0µH, 10A Inductor	1 0 0
C1	C3225X7R1C106M	TDK	10µF/16V, X7R Ceramic Capacitor	1
C2, C3	TPSD686M020R0070 594D686X0020D2T	AVX Vishay/Sprague	68µF, 20V Tantalum	2 0
C4	C2012X5R0J106M	TDK	10µF/6.3V, 0805 Ceramic Capacitor	1
C5, C10, C12, C16	VJ1206Y104KXXAT	Vishay Victramon	0.1µF/25V Ceramic Capacitor	4
C6, C7	TPSD337M006R0045	AVX	330µF/6.3V, Tantalum	2
C8, C11, C17			Open	0
C13	C2012X7R1C105K GRM21BR71C105KA01B VJ1206S105KXJAT	TDK muRata Vishay Victramon	1µF/16V, 0805 Ceramic Capacitor	1 0 0
C15	VJ0603A102KXXAT	Vishay Victramon	1000pF/25V, 0603, NPO	1
R2	CRCW06034700JRT1	Vishay	470Ω, 0603, 1/16W, 5%	1
R3	CRCW08051002FRT1	Vishay	10kΩ, 0805, 1/10W, 1%	1
R4	CRCW08053161FRT1	Vishay	3.16kΩ, 0805, 1/10W, 1%	1
R5	CRCW08054641FRT1	Vishay	4.64kΩ, 0805, 1/10W, 1%	1
R6	CRCW08051132FRT1	Vishay	11.3kΩ, 0805, 1/10W, 1%	1
R7	CRCW08051003FRT1	Vishay	100kΩ, 0805, 1/10W, 1%	1
C9	VJ0603A151KXAAT	Vishay	150pF/50V, 0603, NPO	1

Notes:

1. Micrel, Inc. 408-944-0800
2. Vishay corp 206-452-5664
3. Diodes, Inc 805-446-4800
4. Sumida 408-321-9660
5. TDK 847-803-6100
6. muRata 800-831-9172
7. AVX 843-448-9411
8. International Rectifier 847-803-6100
9. Fairchild Semiconductor 207-775-8100
10. Cooper Electronic 561-752-5000
11. Coilcraft 1-800-322-2645
12. Central Semi 631-435-1110

Bill of Materials (continued)

Item	Part Number	Manufacturer	Description	Qty.
R8	CRCW06034021FRT1	Vishay	4.02k Ω , 0603, 1/16W, 1%	1
R9	CRCW120610R0FRT1	Vishay	10 Ω , 1/8W, 1206, 1%	1
R10	CRCW12062R00FRT1	Vishay	2 Ω , 1/8W, 1206, 1%	1
R12	CRCW12061R40FRT1	Vishay	1.4 Ω , 1/8W, 1206, 1%	
R14			Open	0
J1, J3, J4, J5	2551-2-00-01-00-00-07-0	MillMax	Turrent Pins	4

Notes:

- | | |
|-----------------------------|----------------|
| 13. Micrel.Inc | 408-944-0800 |
| 14. Vishay corp | 206-452-5664 |
| 15. Diodes. Inc | 805-446-4800 |
| 16. Sumida | 408-321-9660 |
| 17. TDK | 847-803-6100 |
| 18. muRata | 800-831-9172 |
| 19. AVX | 843-448-9411 |
| 20. International Rectifier | 847-803-6100 |
| 21. Fairchild Semiconductor | 207-775-8100 |
| 22. Cooper Electronic | 561-752-5000 |
| 23. Coilcraft | 1-800-322-2645 |
| 24. Central Semi | 631-435-1110 |

MIC2169B PCB Layout

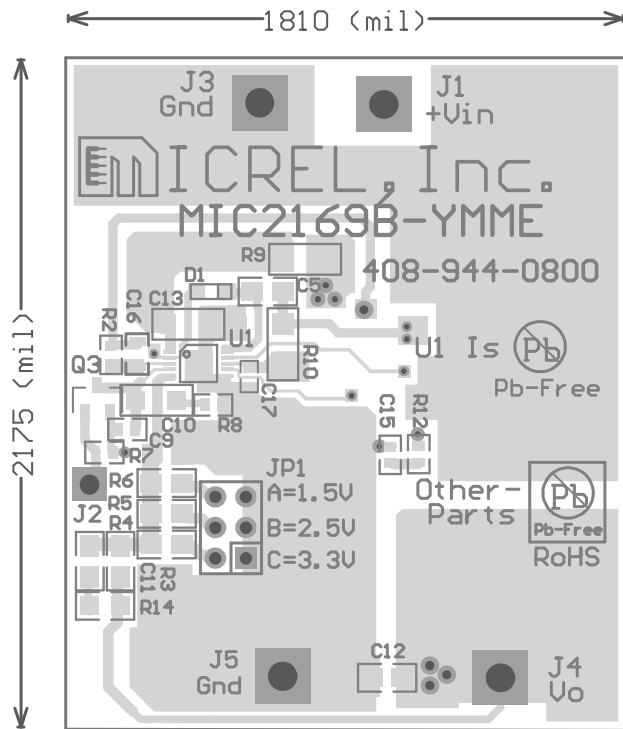

MIC2169B Top Layer

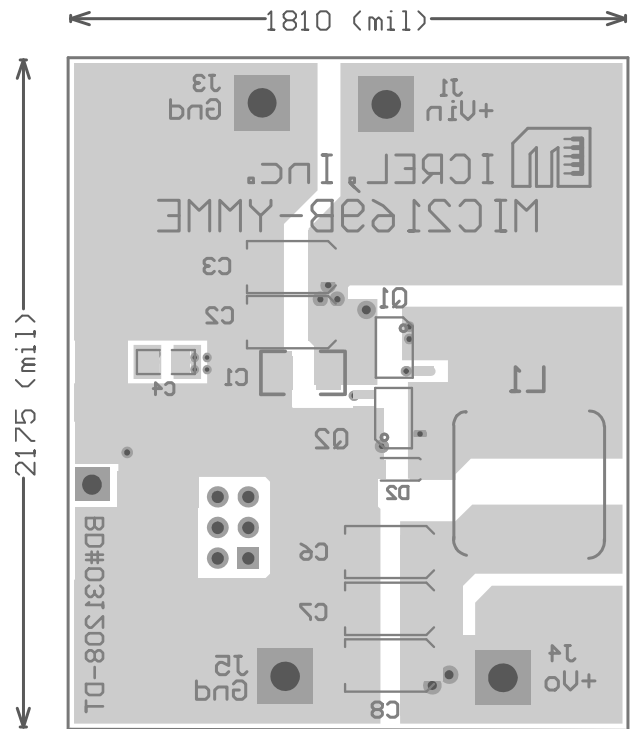

MIC2169B Bottom Layer

Package Information

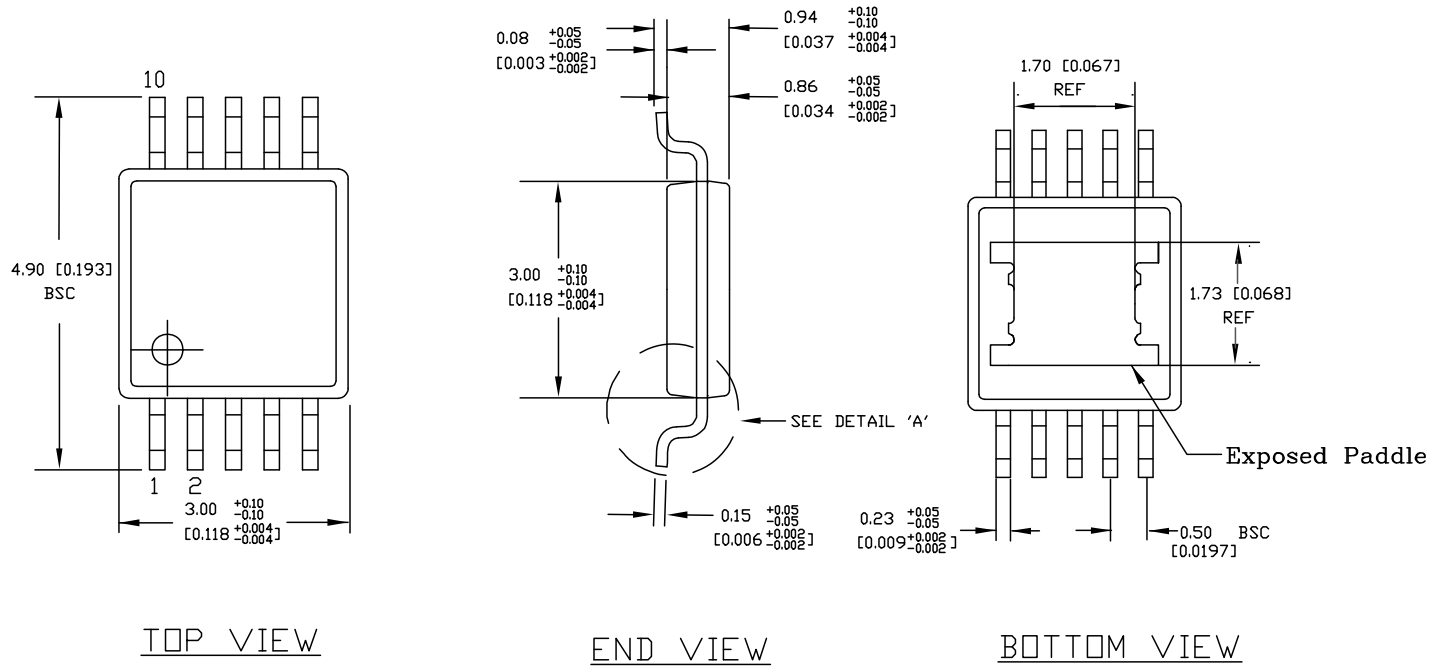

- NOTES:**
1. DIMENSIONS ARE IN MM [INCHES].
 2. CONTROLLING DIMENSION: MM
 3. DIMENSION DOES NOT INCLUDE MOLD FLASH OR PROTRUSIONS, EITHER OF WHICH SHALL NOT EXCEED 0.20 [0.008] PER SIDE.

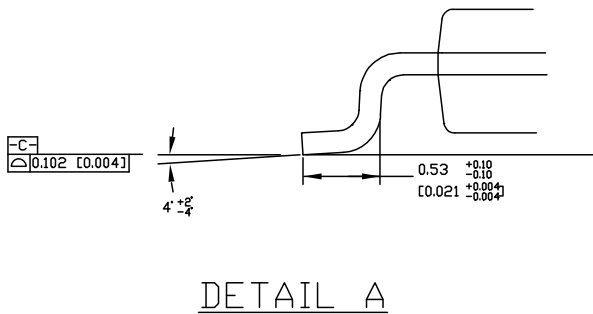

10-Pin ePad MSOP (MME)

Package Information (continued)

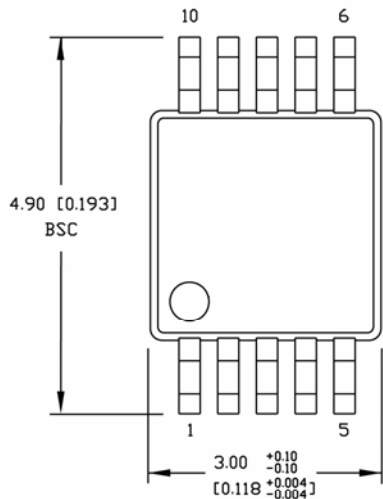

TOP VIEW

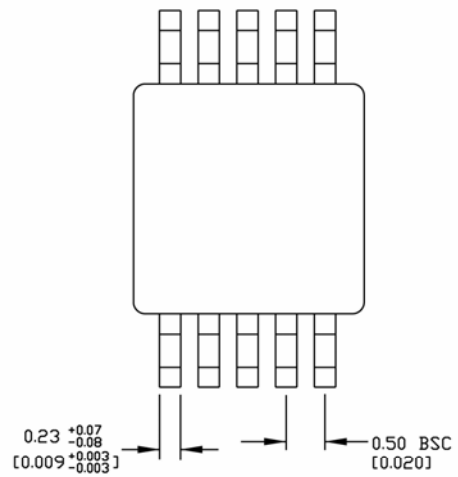

BOTTOM VIEW

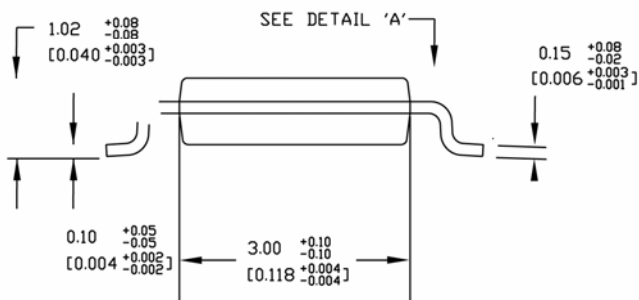

SIDE VIEW

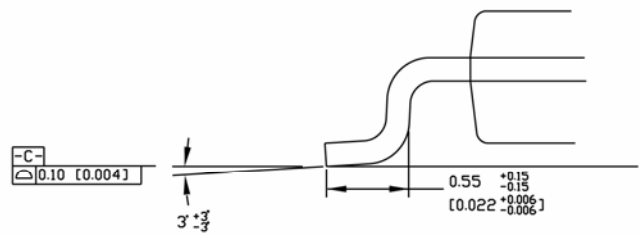

DETAIL A

10-Pin MSOP (MM)

MIC2169B Land Patterns

LP # MSOP-10LD-LP-1
All units are in mm
Tolerance ± 0.05 if not noted

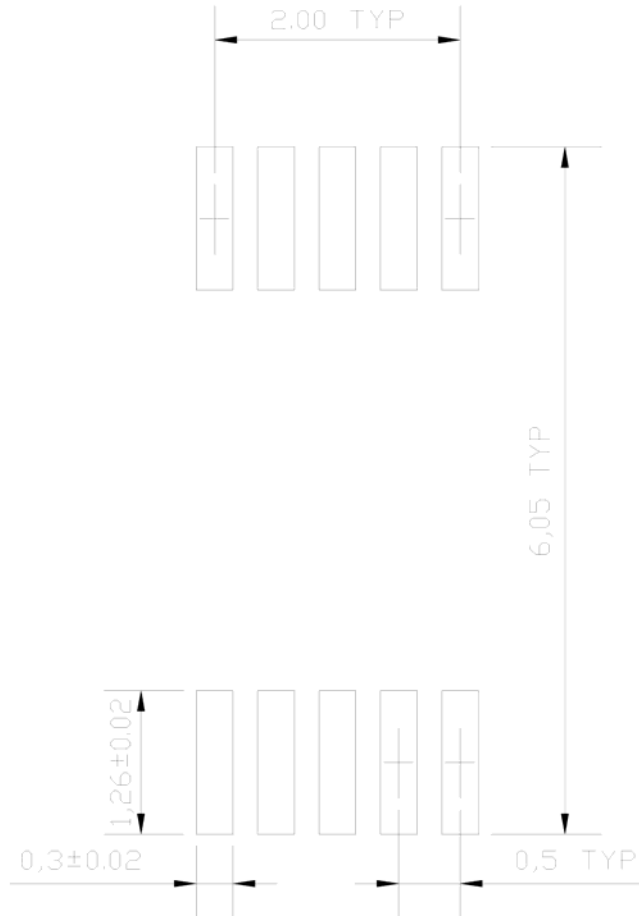

Recommended Land Pattern for 10-Pin MSOP

MIC2169B Land Patterns (continued)

LP # MSOPEP-10LD-LP-1

All units are in mm

Tolerance ± 0.05 if not noted

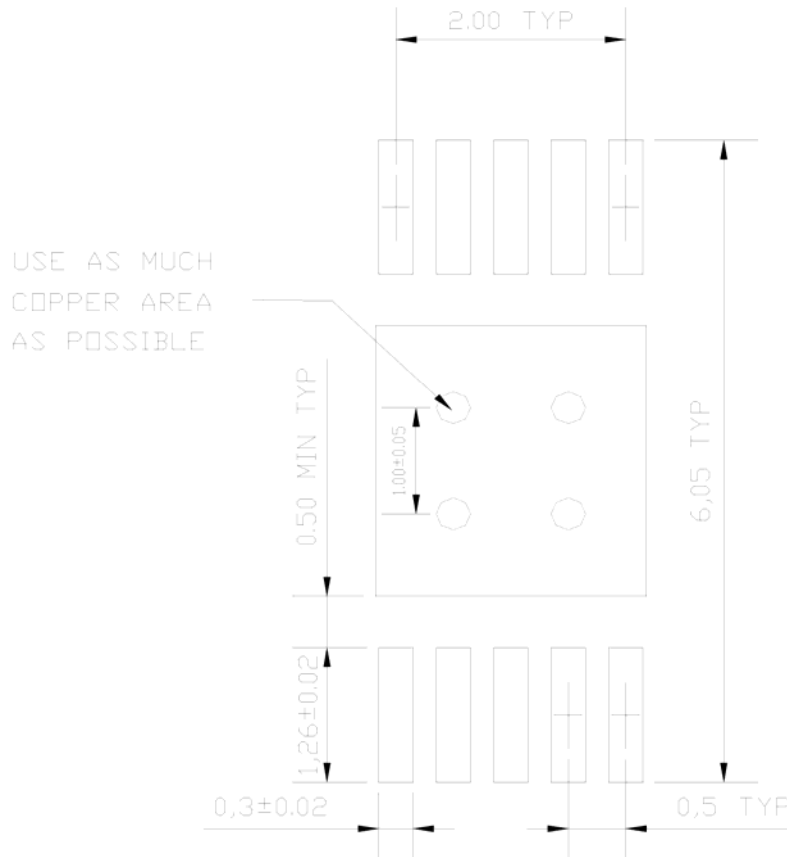

Recommended Land Pattern for ePad 10-Pin MSOP

MICREL, INC. 2180 FORTUNE DRIVE SAN JOSE, CA 95131 USA
 TEL +1 (408) 944-0800 FAX +1 (408) 474-1000 WEB <http://www.micrel.com>

The information furnished by Micrel in this data sheet is believed to be accurate and reliable. However, no responsibility is assumed by Micrel for its use. Micrel reserves the right to change circuitry and specifications at any time without notification to the customer.

Micrel Products are not designed or authorized for use as components in life support appliances, devices or systems where malfunction of a product can reasonably be expected to result in personal injury. Life support devices or systems are devices or systems that (a) are intended for surgical implant into the body or (b) support or sustain life, and whose failure to perform can be reasonably expected to result in a significant injury to the user. A Purchaser's use or sale of Micrel Products for use in life support appliances, devices or systems is a Purchaser's own risk and Purchaser agrees to fully indemnify Micrel for any damages resulting from such use or sale.

© 2006 Micrel, Incorporated.

Компания «Life Electronics» занимается поставками электронных компонентов импортного и отечественного производства от производителей и со складов крупных дистрибьюторов Европы, Америки и Азии.

С конца 2013 года компания активно расширяет линейку поставок компонентов по направлению коаксиальный кабель, кварцевые генераторы и конденсаторы (керамические, пленочные, электролитические), за счёт заключения дистрибьюторских договоров

Мы предлагаем:

- Конкурентоспособные цены и скидки постоянным клиентам.
- Специальные условия для постоянных клиентов.
- Подбор аналогов.
- Поставку компонентов в любых объемах, удовлетворяющих вашим потребностям.
- Приемлемые сроки поставки, возможна ускоренная поставка.
- Доставку товара в любую точку России и стран СНГ.
- Комплексную поставку.
- Работу по проектам и поставку образцов.
- Формирование склада под заказчика.
- Сертификаты соответствия на поставляемую продукцию (по желанию клиента).
- Тестирование поставляемой продукции.
- Поставку компонентов, требующих военную и космическую приемку.
- Входной контроль качества.
- Наличие сертификата ISO.

В составе нашей компании организован Конструкторский отдел, призванный помогать разработчикам, и инженерам.

Конструкторский отдел помогает осуществить:

- Регистрацию проекта у производителя компонентов.
- Техническую поддержку проекта.
- Защиту от снятия компонента с производства.
- Оценку стоимости проекта по компонентам.
- Изготовление тестовой платы монтаж и пусконаладочные работы.



Тел: +7 (812) 336 43 04 (многоканальный)

Email: org@lifeelectronics.ru