

1.8V Operating Voltage 3rd Overtone Quartz Crystal Oscillator IC with Input Tolerant Function

GENERAL DESCRIPTION

The NJU6227 series is a C-MOS quartz crystal oscillator IC realized excellent frequency stability for 3rd Overtone (up to 160MHz) oscillation, and consists of an oscillation amplifier, a 3-state output buffer, a built-in LDO and a input tolerant circuit.

The operating voltage is from 1.62V to 3.63V (x3, x4, x5, x6: from 2.25V to 3.63V), and the LDO holds down the characteristic change of the oscillation amplifier for operating voltage variation, and has been stabilized oscillation frequency (Frequency stability $\pm 1\text{ppm}@V_{DD}\pm 10\%$). The 3-state output buffer is C-MOS compatible.

The input tolerant circuit ensures that 0 to 3.63 V can be applied to CONT terminal without regard to the supply voltage.

The oscillation stopping current is very low stand-by mode, therefore, it is suitable for the portable items of the communication equipment and the like.

PACKAGE OUTLINE



NJU6227xXC-V

FEATURES

- Maximum Oscillation Frequency 160MHz(3rd Overtone)
- Frequency Stability $\pm 1\text{ppm}@V_{DD}\pm 10\%$
- Wide Operating Voltage 1.62 to 3.63V(x3, x4, x5, x6 2.25V to 3.63V)
- Built-in LDO
- Input Tolerant Circuit 0 to 3.63V@CONT Term.
- Stand-by Function (Oscillation Stop and High-Z)
- 3-State Output Buffer
- Variable Pull-up Resistance on-Die (CONT Terminal: Pull-up resistance is large at Stand-by Function)
- Oscillation Capacitors Cg and Cd on-Die
- C-MOS Technology
- Package Outline Die/Wafer

BLOCK DIAGRAM

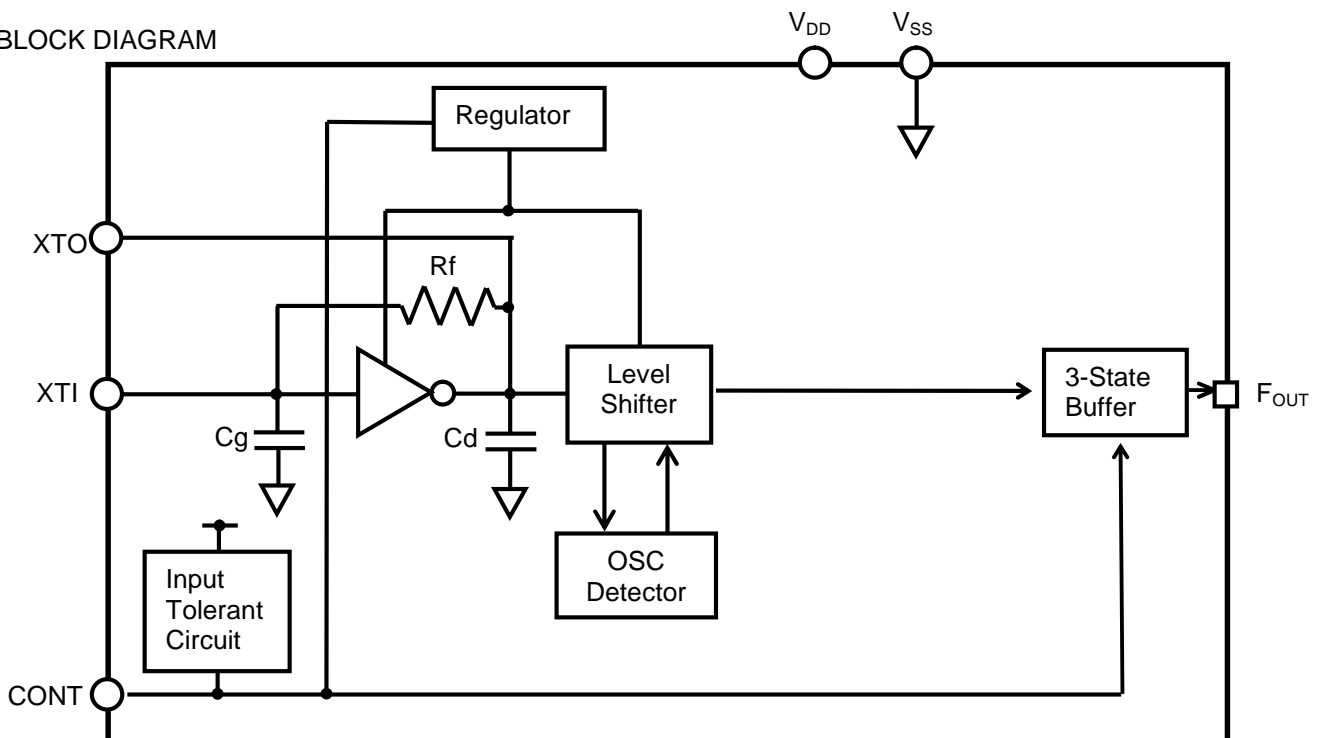

LINE-UP TABLE

Type No.	Recommended Oscillation Frequency	Version		
		Type A	Type B	Type C
NJU6227	40 to 50MHz	A1*	B1*	C1
	50 to 60MHz	A2*	B2*	C2
	60 to 85MHz	A3*	B3*	C3
	85 to 110MHz	A4*	B4*	C4
	110 to 130MHz	A5*	B5*	C5
	130 to 160MHz	A6*	B6*	C6

* Under development and tentative value.

PAD LOCATION

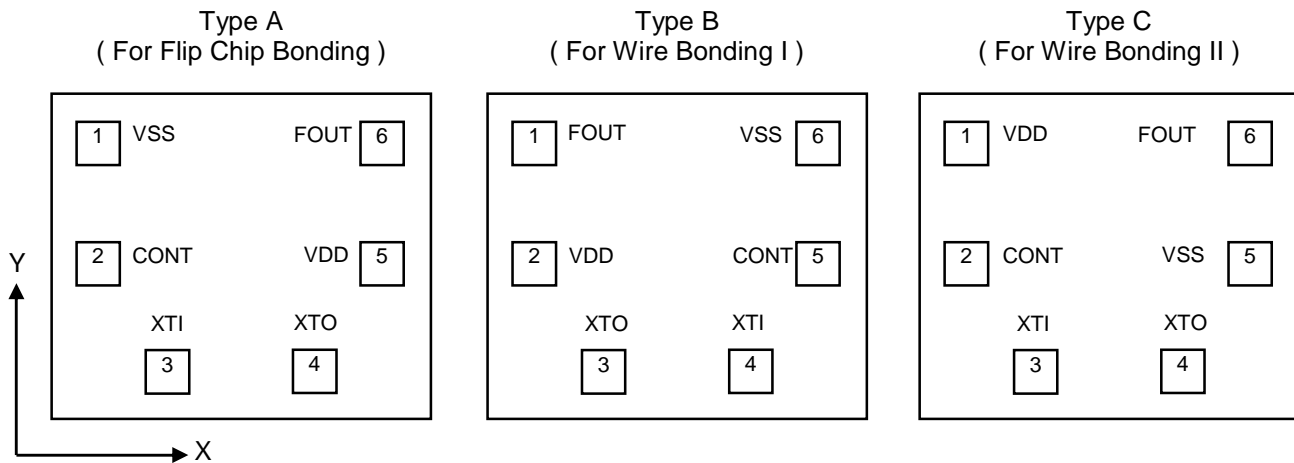

COORDINATES

	X	Y
1	-261.5	198.5
2	-261.5	-21.5
3	-146.5	-211.5
4	144.5	-211.5
5	260.5	-21.5
6	260.5	198.5

PART NUMBER

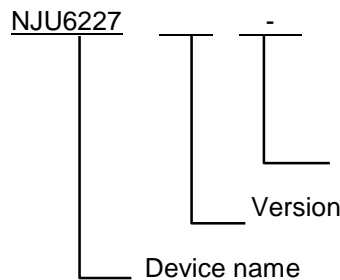

W-H: Wafer (200μm)
W-B: Wafer (160μm)
WS4-V: 1/4Wafer(130μm)
C-V: Chip(130μm)

Starting Point: Die Center Unit[μm]
Die Size: 0.73x0.63mm
Die Thickness (C-V): 130±15μm
Wafer Thickness(WS4-V): 130±15μm
Wafer Thickness (W-B): 160±20μm
Wafer Thickness (W-H): 200±20μm
Pad size: 80x80μm
Die Substrate: V_{SS} level

VERSION DISCRIMINATION INTERNAL COMPONENTS

PAD layout version of the NJU6227 series is determined by the mask pattern. Frequency version of the NJU6227 series is determined by the internal fuse trimming.

Laser-trimmed versions are identified externally by the combination of the version name marking (1) and the locations of trimmed fuses (2). (Table 1 shows the chip version identification)

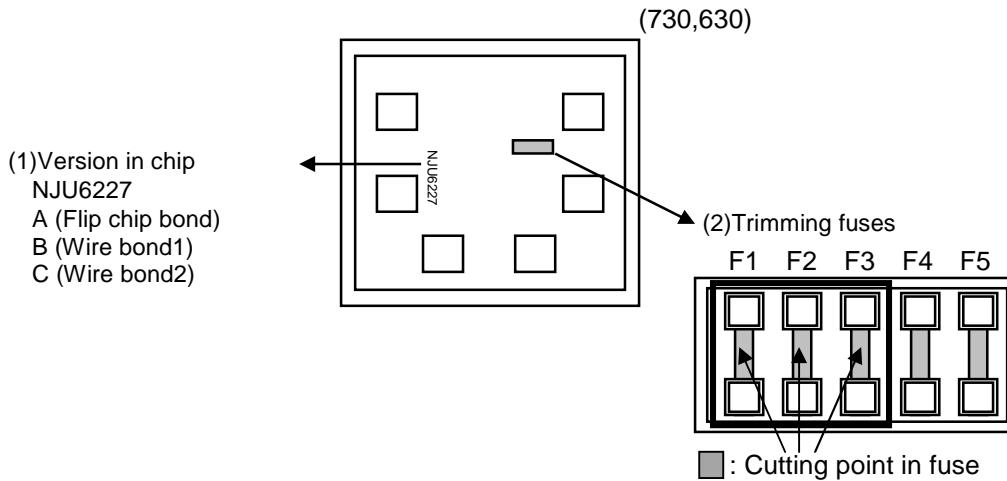

Table1: Frequency version and Cutting point in fuse.

Version name	Mask / Version set by trimming fuses					
	Mask	Trimming fuses				
	Version	F1	F2	F3	F4	F5
NJU6227A1	A	*	-	-	Untrimmed	
NJU6227A2	A	*	-	*		
NJU6227A3	A	-	-	-		
NJU6227A4	A	-	-	*		
NJU6227A5	A	-	*	-		
NJU6227A6	A	-	*	*		
NJU6227B1	B	*	-	-		
NJU6227B2	B	*	-	*		
NJU6227B3	B	-	-	-		
NJU6227B4	B	-	-	*		
NJU6227B5	B	-	*	-		
NJU6227B6	B	-	*	*		
NJU6227C1	C	*	-	-		
NJU6227C2	C	*	-	*		
NJU6227C3	C	-	-	-		
NJU6227C4	C	-	-	*		
NJU6227C5	C	-	*	-		
NJU6227C6	C	-	*	*		

Note1) “-”: Uncut, “*”: Cutting

TERMINAL DESCRIPTION

SYMBOL	FUNCTION
CONT	Oscillation and 3-state Output Buffer Control
	CONT F _{OUT}
	H or OPEN Output frequency f ₀
	L Oscillation Stop and High impedance Output
XTI	Quartz Crystal Connecting Terminals
XTO	
V _{SS}	GND Terminal (V _{SS} =0V)
F _{OUT}	Frequency Output
V _{DD}	V _{DD} =1.62 to 3.63V (x3, x4, x5, x6 2.25 to 3.63V)

FUNCTIONAL DESCRIPTION

Standby Function

When CONT Terminal goes "Low", the F_{OUT} Terminal output becomes High impedance.

CONT	F _{OUT}	Oscillator
High(Open)	Frequency output	Normal operation
Low	High impedance	Stopped

Variable Pull-up Resistance

The CONT Terminal pull-up resistance changes in response to the input level. When CONT is tied "LOW" level, the pull-up resistance is large, reducing the current consumed by the resistance. When CONT is left open circuit, the pull-up resistance is small, which increases the input susceptibility to external noise. However, the pull-up resistance ties the CONT Terminal "High" level to prevent external noise from unexpectedly stopping the output.

ABSOLUTE MAXIMUM RATINGS

(V_{SS}=0V, Ta=25°C)

PARAMETER	SYMBOL	RATING	UNIT
Supply Voltage	V _{DD}	-0.5 to +4.0	V
Input Voltage	V _{IN}	-0.5 to +4.0	V
Output Voltage	V _O	-0.5 to V _{DD} +0.5	V
Input Current	I _{IN}	±10	mA
Output Current	I _O	±25	mA
Operating Temperature Range	T _{opr}	-40 to +85	°C
Storage Temperature Range	T _{stg}	-55 to +125	°C

Note1) Decoupling capacitor should be connected between V_{DD} and V_{SS} due to the stabilized operation for the circuit.

ELECTRICAL CHARACTERISTICS

(Ta=+25°C)

PARAMETER	SYMBOL	CONDITIONS	MIN	TYP	MAX	UNIT
Operating Voltage	V _{DD}	x1,x2, version	1.62		3.63	V
Input Voltage	V _{IN}	CONT	0		3.63	V
Output Voltage	V _{OUT}	F _{OUT}	0		V _{DD}	V
Output Frequency Stability	df/f	V _{DD} ±10%		±1		ppm

(Ta=+25°C)

PARAMETER	SYMBOL	CONDITIONS	MIN	TYP	MAX	UNIT
Operating Voltage	V _{DD}	x3, x4, x5, x6 version	2.25		3.63	V
Input Voltage	V _{IN}	CONT	0		3.63	V
Output Voltage	V _{OUT}	F _{OUT}	0		V _{DD}	V
Output Frequency Stability	df/f	V _{DD} ±10%		±1		ppm

Note3) C0 minimum requirement

Version: x1, x2, x3, x4, x5 1pF

Version: x6 1.5pF

($V_{DD}=1.62$ to $3.63V$ (x3, x4, x5, x6 2.25 to $3.63V$), $V_{SS}=0V$, $T_a=+25^{\circ}C$)

PARAMETER	SYMBOL	CONDITIONS	MIN	TYP	MAX	UNIT	
Operating Current	I_{DD}	x1 version No load CONT=Open $f_{osc}=50MHz$	$V_{DD}=1.8V$	-	2.0	2.6	mA
			$V_{DD}=2.5V$	-	2.4	3.1	
			$V_{DD}=3.3V$	-	3.1	4.0	
		x2 version No load CONT=Open $f_{osc}=60MHz$	$V_{DD}=1.8V$	-	2.4	3.1	
			$V_{DD}=2.5V$	-	2.8	3.6	
			$V_{DD}=3.3V$	-	3.6	4.7	
		x3 version No load CONT=Open $f_{osc}=85MHz$	$V_{DD}=2.5V$	-	6.0	7.8	
			$V_{DD}=3.3V$	-	7.0	9.1	
		x4 version No load CONT=Open $f_{osc}=110MHz$	$V_{DD}=2.5V$	-	6.6	8.6	
			$V_{DD}=3.3V$	-	7.8	10.1	
		x5 version No load CONT=Open $f_{osc}=130MHz$	$V_{DD}=2.5V$	-	6.8	8.8	
			$V_{DD}=3.3V$	-	8.2	10.7	
		x6 version No load CONT=Open $f_{osc}=160MHz$	$V_{DD}=2.5V$	-	7.5	9.8	
			$V_{DD}=3.3V$	-	9.0	11.7	
Oscillation Stopping Current	I_{STB}	CONT= V_{SS} , No load	-	-	10	μA	
Output Voltage	V_{OH}	$I_{OH}=4mA$	$V_{DD}-0.4$	-	-	V	
	V_{OL}	$I_{OL}=4mA$	-	-	0.4	V	
Input Voltage	V_{IH}	CONT Input Tolerant Function	$0.7V_{DD}$	-	-	V	
	V_{IL}	CONT	-	-	$0.3V_{DD}$	V	
Input Current Note1)	I_{IN}	CONT= $3.63V$	-	-	1	μA	
		CONT= $0.8V_{DD}$	-	-	8		
		CONT= $0.2V_{DD}$	-	-	5		
3-state Off Leakage Current	I_{OZ}	CONT= V_{SS} , $F_{OUT}=V_{DD}$ or V_{SS}	-	-	± 0.1	μA	

Note1) Absolute value.

($V_{DD}=1.62$ to $3.63V$ (x3, x4, x5, x6 2.25 to $3.63V$), $V_{SS}=0V$, $T_a=+25^{\circ}C$)

PARAMETER	SYMBOL	CONDITIONS	MIN	TYP	MAX	UNIT	
Feedback Resistance	Rf	x1 version	-	12.5	-	kΩ	
		x2 version	-	6.8	-		
		x3 version	-	6.8	-		
		x4 version	-	12.3	-		
		x5 version	--	12.4	-		
		x6 version	-	12.5	-		
Internal Capacitor	Cg/Cd	x1 version	-	7.2/7.2	-	pF	
		x2 version	-	7.2/7.2	-		
		x3 version	-	7.2/7.2	-		
		x4 version	-	5.1/5.4	-		
		x5 version	-	4.2/4.1	-		
		x6 version	-	3.1/3.1	-		
Oscillation Frequency	fosc	Recommendation Note1)	40		50	MHz	
			50		60		
			60		85		
			85		110		
			110		130		
			130		160		
Output Signal Symmetry	SYM	$C_L=15pF$, @ $V_{DD}/2$	45	50	55	%	
Output Signal Rise Time	tr	$C_L=15pF$ $0.1V_{DD}$ to $0.9V_{DD}$	$V_{DD}=1.8V$	-	2.0	4.0	ns
			$V_{DD}=2.5V$	-	1.1	2.1	
			$V_{DD}=3.3V$	-	0.8	1.7	
Output Signal Fall Time	tf	$C_L=15pF$ $0.9V_{DD}$ to $0.1V_{DD}$	$V_{DD}=1.8V$	-	1.7	3.4	ns
			$V_{DD}=2.5V$	-	1.0	1.9	
			$V_{DD}=3.3V$	-	0.8	1.5	
Output Disable time	t_{POZ}	$C_L=15pF$, $R_L=1k\Omega$	-	-	100	ns	
Output Enable Time	t_{PZO}	$C_L=15pF$	-	-	1	ms	

Note1) The oscillation frequency range has used NJRC's standard crystal for measurement. However it is not guaranteed. (Refer to EXAMPLE OF CRYSTAL PARAMETERS FOR MEASUREMENT CIRCUITS)

EXAMPLE OF CRYSTAL PARAMETERS FOR MEASUREMENT CIRCUITS

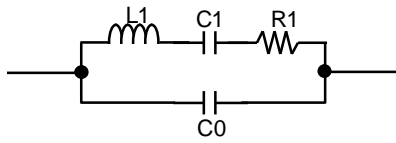

f[MHz]	R1[Ω]	L1[mH]	C1[fF]	C0[pF]	Size
40	34.8	20.8	0.76	2.42	7050
50	67.1	27.5	0.37	1.46	7050
60	33.1	10.7	0.66	2.49	7050
90	42.2	6.68	0.47	2.03	7050
113	30.2	3.52	0.56	3.22	7050
125	30.3	2.61	0.62	3.47	7050
133	24.7	2.11	0.68	3.60	7050
155	38.3	1.55	0.68	3.75	7050

MEASUREMENT CIRCUITS

(1) Operating Current ($C_L=0pF$), Output Signal Symmetry ($C_L=15pF$), Output Signal Rise/Fall Time ($C_L=15pF$)

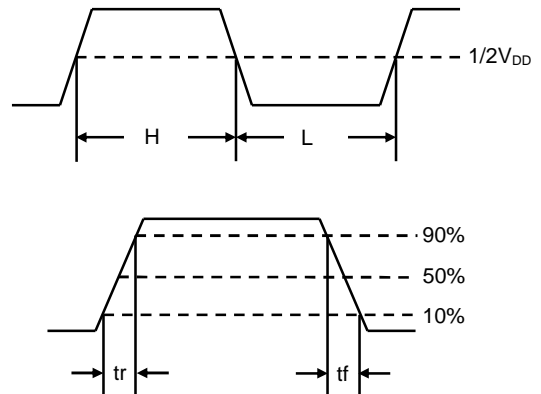
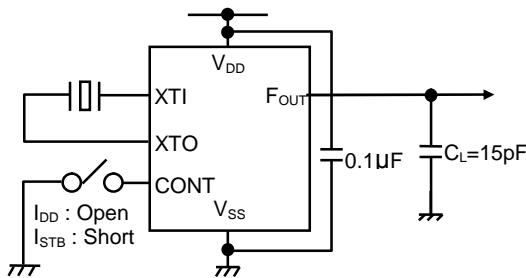

(2) Output Disable Time ($C_L=15pF, R_L=1kΩ$)

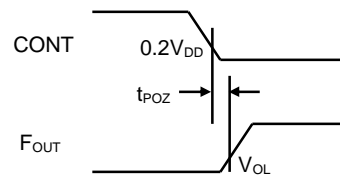
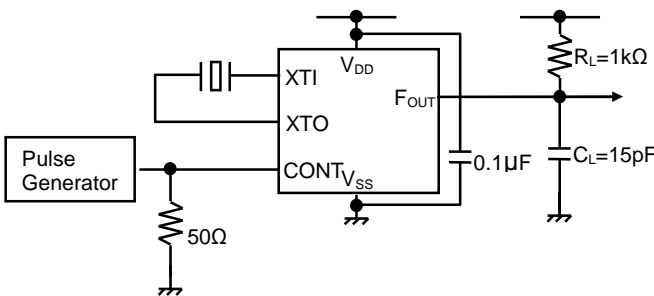

(3) Output Enable Time ($C_L=15pF$)

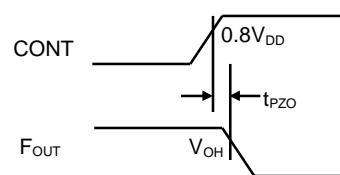
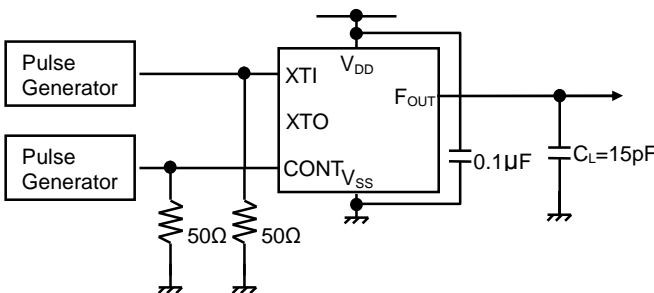

(4) Input Current ($C_L=15\text{pF}$)

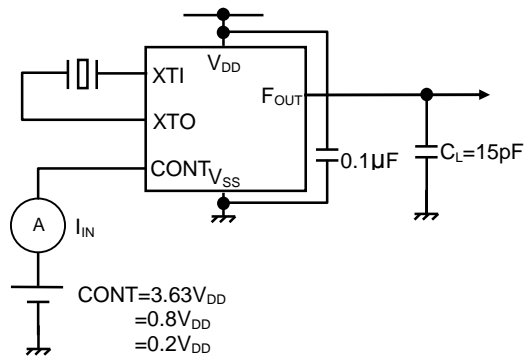

[CAUTION]
 The specifications on this data book are only given for information, without any guarantee as regards either mistakes or omissions. The application circuits in this data book are described only to show representative usages of the product and not intended for the guarantee or permission of any right including the industrial rights.

Mouser Electronics

Authorized Distributor

Click to View Pricing, Inventory, Delivery & Lifecycle Information:

[NJR:](#)

[NJU6227](#)

Компания «Life Electronics» занимается поставками электронных компонентов импортного и отечественного производства от производителей и со складов крупных дистрибьюторов Европы, Америки и Азии.

С конца 2013 года компания активно расширяет линейку поставок компонентов по направлению коаксиальный кабель, кварцевые генераторы и конденсаторы (керамические, пленочные, электролитические), за счёт заключения дистрибьюторских договоров

Мы предлагаем:

- Конкурентоспособные цены и скидки постоянным клиентам.
- Специальные условия для постоянных клиентов.
- Подбор аналогов.
- Поставку компонентов в любых объемах, удовлетворяющих вашим потребностям.
- Приемлемые сроки поставки, возможна ускоренная поставка.
- Доставку товара в любую точку России и стран СНГ.
- Комплексную поставку.
- Работу по проектам и поставку образцов.
- Формирование склада под заказчика.
- Сертификаты соответствия на поставляемую продукцию (по желанию клиента).
- Тестирование поставляемой продукции.
- Поставку компонентов, требующих военную и космическую приемку.
- Входной контроль качества.
- Наличие сертификата ISO.

В составе нашей компании организован Конструкторский отдел, призванный помогать разработчикам, и инженерам.

Конструкторский отдел помогает осуществить:

- Регистрацию проекта у производителя компонентов.
- Техническую поддержку проекта.
- Защиту от снятия компонента с производства.
- Оценку стоимости проекта по компонентам.
- Изготовление тестовой платы монтаж и пусконаладочные работы.



Тел: +7 (812) 336 43 04 (многоканальный)
Email: org@lifeelectronics.ru