

## 6x8 MATRIX LED DRIVER

### DESCRIPTION

The IS32FL3738 is an automotive grade general purpose 6x8 LEDs matrix driver with 1/12 cycle rate. The device can be programmed via an I2C compatible interface. Each LED can be dimmed individually with 8-bit × 4 PWM data which allowing 512 steps of linear dimming.

IS32FL3738 features 3 Auto Breathing Modes which are noted as ABM-1, ABM-2 and ABM-3. For each Auto Breathing Mode, there are 4 timing characters which include current rising / holding / falling / off time and 3 loop characters which include Loop-Beginning / Loop-Ending / Loop-Times. Every LED can be configured to be any Auto Breathing Mode or No-Breathing Mode individually.

### FEATURES

- Up to 48 LEDs (6x8) in dot matrix
- Programmable 6x8 (16 RGBs) matrix size with de-ghost function
- Selectable 3 Auto Breath Modes for each dot
- Auto Breath Loop Features interrupt pin inform MCU Auto Breath Loop completed
- Auto Breath offers 128 steps gamma current, interrupt and state look up registers
- 256 steps Global Current Setting
- Individual 512 PWM control steps
- Individual Auto Breath Mode select
- Individual open and short error detect function

### QUICK START



Figure 1: Photo of IS32FL3738 Evaluation Board

(V01A board with 12V DC input please refer to Appendix I)

### RECOMMENDED EQUIPMENT

- 5.0V, 2A Micro USB
- Arduino IDE, [www.arduino.cc/en/Main/Software](http://www.arduino.cc/en/Main/Software)
- Arduino code download from ISSI website

### ABSOLUTE MAXIMUM RATINGS

- ≤ 5.5V Micro USB DC power supply

**Caution: Do not exceed the conditions listed above, otherwise the board will be damaged.**

### PROCEDURE

The IS32FL3738 evaluation board is fully assembled, tested and comes programmed with evaluation software. Follow the steps listed below to verify board operation.

**Caution: Do not turn on the power supply until all connections are completed.**

- 1) Connect the 5VDC USB power to the Micro USB.
- 2) Press K1 to cycle through a display mode.

### EVALUATION BOARD OPERATION

The IS32FL3738 evaluation board drives 16 RGB LEDs located underneath the light dispersing filter. Every press of the K1 switch will cycle through one of the 8 pre-programmed lighting sequences below:

- 1) White LED
- 2) Rainbow bar
- 3) Red color breath
- 4) Green color breath
- 5) Blue color breath
- 6) Pink color breath
- 7) Yellow color breath
- 8) Cyan color breath

**Note: IS32FL3738 solely controls the FxLED function on the evaluation board.**

### ORDERING INFORMATION

Part No.	Temperature Range	Package
IS32FL3738-ZLA3-EB	-40°C to +125°C (Automotive)	eTSSOP-28, Lead-free

Table 1: Ordering Information

For pricing, delivery, and ordering information, please contact ISSI's analog marketing team at [analog@issi.com](mailto:analog@issi.com) or (408) 969-6600.

### SOFTWARE CONTROL

The evaluation board comes with an Arduino compatible microcontroller circuit preloaded with IS32FL3738 demonstration firmware, called a sketch. This allows the functionality of the IS32FL3738 to be verified before starting firmware development.

The Arduino hardware consists of an Atmel microcontroller with a bootloader allowing quick firmware updates. First download the latest Arduino Integrated Development Environment IDE (1.6.12 or greater) from [www.arduino.cc/en/Main/Software](http://www.arduino.cc/en/Main/Software). Then download the latest IS32FL3738 firmware (sketch) from the ISSI website [www.issi.com/US/product-analog-automotive.shtml](http://www.issi.com/US/product-analog-automotive.shtml). When using the Arduino environment, please select Genuino UNO as shown below, then select the serial port. Follow the standard procedure to upload the latest IS32FL3738 firmware into the Arduino; then use the IDE to modify it. There is no additional software required to run the eval board.

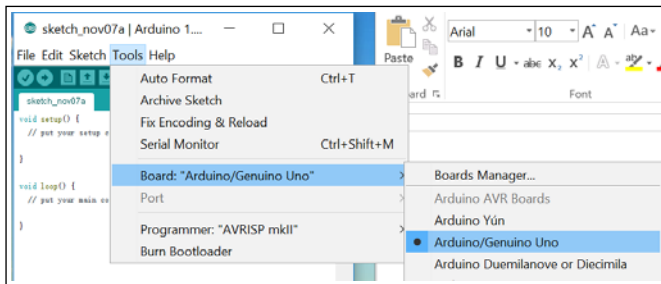

### EXT-SOFTWARE CONTROL

The IS32FL3738 can also be driven by an external IIC source.

Follow the steps below to configure the eval board for external control.

- 1) Open the two pins of J7 on the right side, to disable the onboard Arduino and enable external control (the SDA SCL and SDB become high impedance).
- 2) Default VIO is 5V, if you use a 3.3V IO, connect 3.3V to VIO pin in J7.
- 3) Connect SDB to VIO or high level IO
- 4) Connect external IIC to the IIC pins of J7
- 5) Start external IIC control.

*Please refer to the datasheet to get more information about IS32FL3738*

# 6x8 MATRIX LED DRIVER

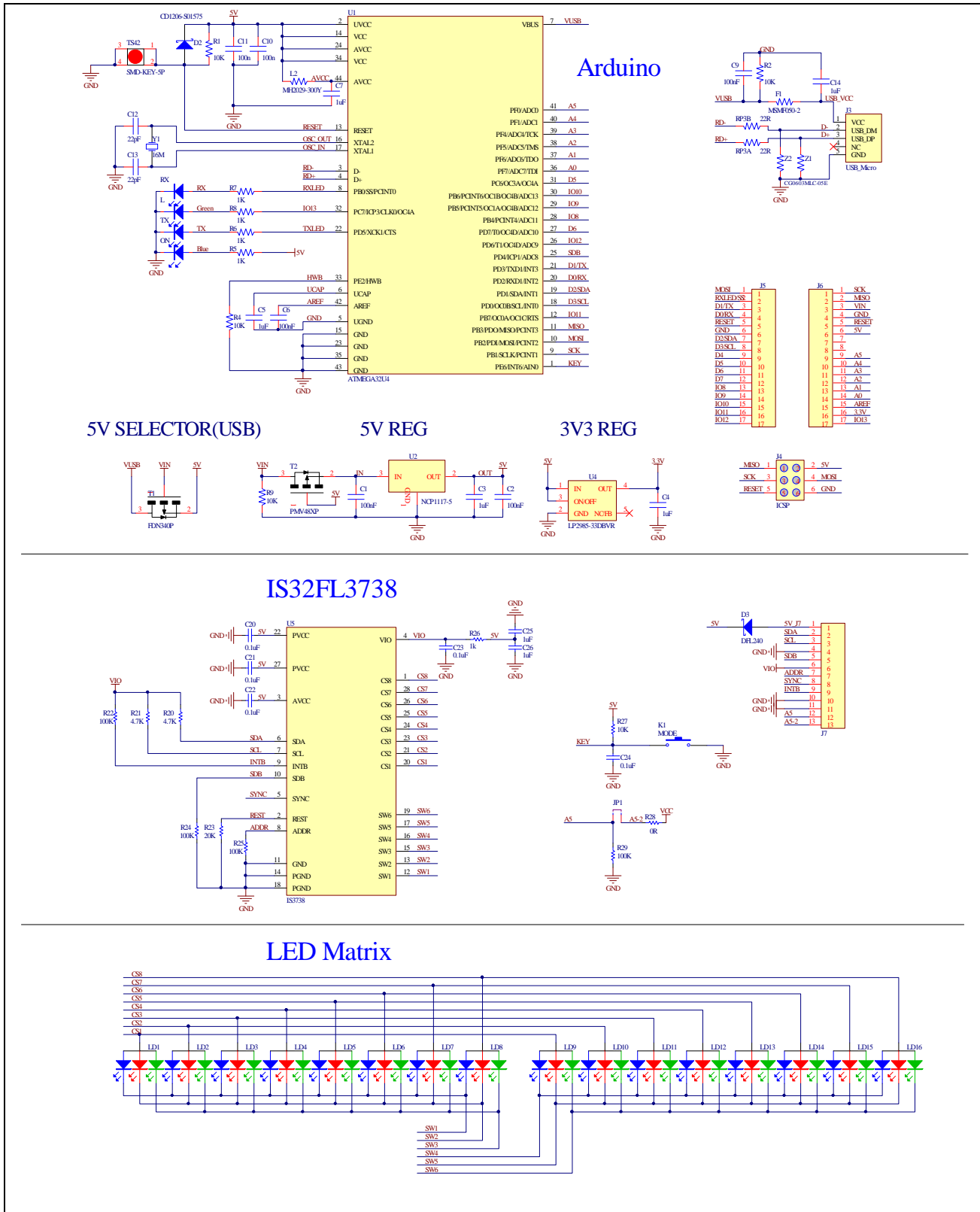

Figure 2: IS32FL3738 Application Schematic

## 6x8 MATRIX LED DRIVER

### BILL OF MATERIALS - Arduino

Name	Symbol	Description	Qty	Supplier	Part No.
MCU	U1	Microcontroller	1	ATM	ATMEGA32U4
LDO	U2	Reduced voltage	1	ON	NCP1117-5
LDO	U4	Reduced voltage	1	TI	LP2985-33DBVR
Triode	T1	FET	1	FAIRCHILD	FDN340P
Triode	T2	FET	1	NXP	PMV48XP
Crystal	Y1	Crystal, 16MHz	1	Risym	3225 16MHz
Button	K1	Button SMD	1	MT	SMD-KEY-5P
LED	ON,TX,RX	LED, SMD Blue	3	EVERLIGHT	0603
LED	L	LED, SMD Green	1	EVERLIGHT	0603
F1	F1	SMD Fuse	1	MF	MSMF050-2
Beads	L2	Beads	1	BOURNS	MH2029-300Y
Diode	D2	Diode, SMD	1	BOURNS	CD1206-S01575
Varistor	Z1,Z2	Varistor	2	BOURNS	CG0603MLC-05E
Resistor	RP3A,PR3B	RES,22R,1/16W,±5%,SMD	2	Yageo	RC0603JR-0722RL
Resistor	R5,R6,R7,R8	RES,1k,1/16W,±5%,SMD	4	Yageo	RC0603JR-071KL
Resistor	R1,R2,R4,R9	RES,10k,1/16W,±5%,SMD	4	Yageo	RC0603JR-0710KL
Capacitor	C12,C13	CAP,22pF,16V,±20%,SMD	2	Yageo	CC0603KKX7R9BB22
Capacitor	C1,C2,C6,C9,C10,C11	CAP,100nF,16V,±20%,SMD	6	Yageo	CC0603KKX7R9BB101
Capacitor	C3,C4,C5,C7,C14	CAP,1µF,16V, ±20%,SMD	4	Yageo	CC0603KKX7R9BB105

### BILL OF MATERIALS – IS32FL3738

Name	Symbol	Description	Qty	Supplier	Part No.
LED Driver	U5	Matrix LED Driver	1	ISSI	IS32FL3738
RGB LED	LD1~LD16	RGB LED, SMD	16	ROHM	SMLV56RGB1W1
Diode	D3	Diode, SMD	1	DIODES	DFLS240
Resistor	R20,R21	RES,4.7k,1/16W,±5%,SMD	2	Yageo	RC0603JR-074K7L
Resistor	R22,R24,R25,R29	RES,100k,1/16W,±5%,SMD	4	Yageo	RC0603JR-07100KL
Resistor	R23	RES,20k,1/16W,±5%,SMD	1	Yageo	RC0603JR-0720KL
Resistor	R26	RES,1k,1/16W,±5%,SMD	1	Yageo	RC0603JR-071KL
Resistor	R27	RES,10k,1/16W,±5%,SMD	1	Yageo	RC0603JR-0710KL
Resistor	R28	RES,0k,1/16W,±5%,SMD	1	Yageo	RC0603JR-070KL
Capacitor	C20,C21,C22,C23,C24	CAP,0.1µF,16V,±20%,SMD	5	Yageo	CC0603KKX7R9BB104
Capacitor	C25,C26	CAP,1µF,16V,±20%,SMD	2	Yageo	CC0603KKX7R9BB105
Button	K1(Bottom)	Button	1		

Bill of Materials, refer to Figure 1 above.

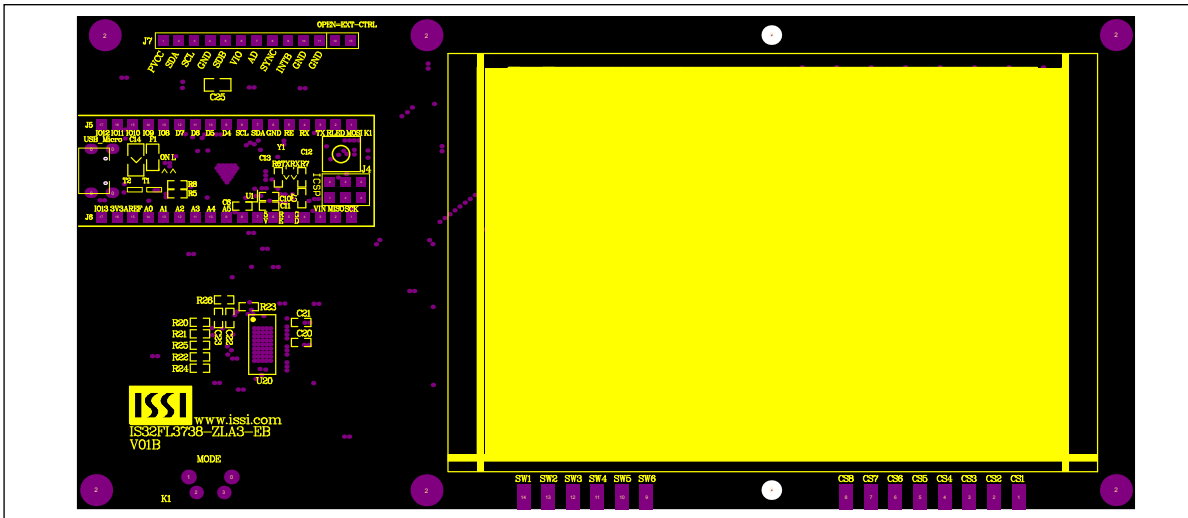

Figure 3: Board Component Placement Guide - Top Layer

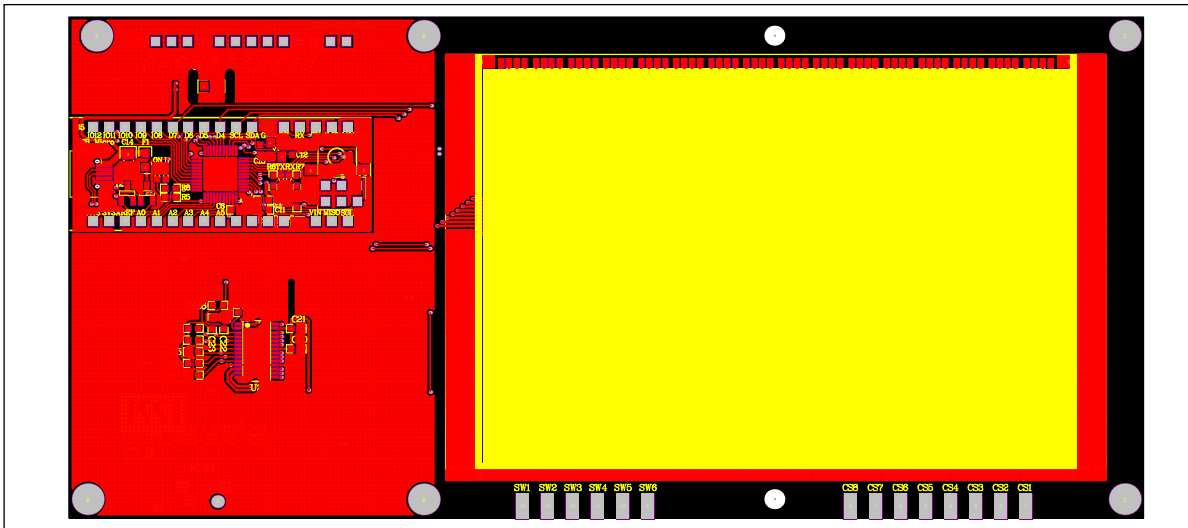

Figure 4: Board PCB Layout - Top Layer





## 6x8 MATRIX LED DRIVER

---

### REVISION HISTORY

---

Revision	Detail Information	Date
A	Initial release	2016.09.18
B	1. Deleted 12V, 1A power supply. 2. Update schematic and PCB. 3. Update bill of materials	2016.11.04
C	Correct the PWM level to 512 levels, please check datasheet for more information.	2017.03.22

## APPENDIX I: V01A GUIDE

### QUICK START

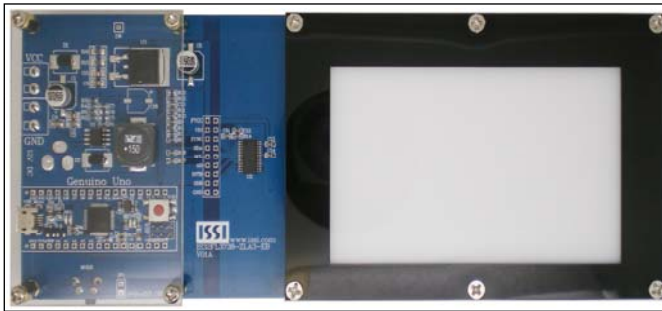

Figure 7: Photo of IS32FL3738 Evaluation Board

### RECOMMENDED EQUIPMENT V01A

- 5.0V, 2A Micro USB or 12V, 1A power supply

### ABSOLUTE MAXIMUM RATINGS V01A

- ≤ 17V DC power supply
- ≤ 5.5V Micro USB DC power supply

**Caution:** Do not exceed the conditions listed above, otherwise the board will be damaged.

### PROCEDURE V01A

The IS32FL3738 evaluation board is fully assembled and tested. Follow the steps listed below to verify board operation.

**Caution:** Do not turn on the power supply until all connections are completed.

- 1) Connect the 12VDC power to the connector or 5VDC USB power to the Micro USB.
- 2) Turn on the power supply, pay attention to the supply current. If the current exceeds 1A, please check for circuit fault.

### EVALUATION BOARD OPERATION V01A

The IS32FL3738 evaluation board has three animation display modes. Press K1 to switch configurations.

- 1) White LED

- 2) Rainbow bar
- 3) Red LED breath
- 4) Green LED breath
- 5) Blue LED breath
- 6) Red and blue LED breath
- 7) Red and green LED breath
- 8) Blue and green LED breath

**Note:** IS32FL3738 solely controls the FxLED function on the evaluation board.

### SOFTWARE CONTROL

The IS32FL3738 use Arduino as its master controller, if using Arduino environment, please select Genuino UNO. No driver is needed when initial the hardware.

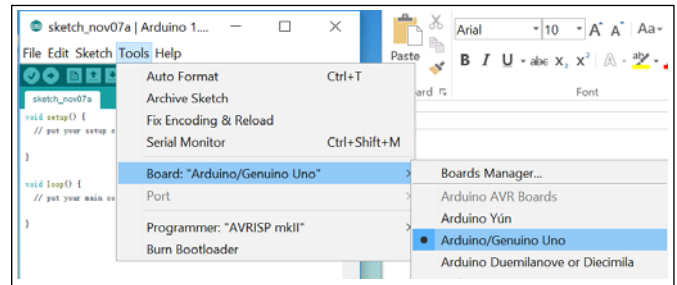

### EXT-SOFTWARE CONTROL V01A

The IS32FL3738 can set its I2C bus interface logic threshold based on the voltage on the VIO pin.

Follow the steps listed below for external control.

- 1) Open JP1 to disconnect the I2C communication, and connect an external MCU VCC to VIO.
- 2) Pull-up the SDB to VIO.
- 3) Connect the 12VDC power to the connector or 5VDC power to the Micro USB.
- 4) Turn on the power supply pay attention to the supply current. If the current exceeds 1A, please check for circuit fault.
- 5) Start external IIC control.

**Please refer to the datasheet to get more information about IS32FL3738**





## 6x8 MATRIX LED DRIVER

### BILL OF MATERIALS (EVB Part)

Name	Symbol	Description	Qty	Supplier	Part No.
Buck Chip	U1	Buck Chip	1	ISSI	IS32PM3415
LED Driver	U2	Matrix LED Driver	1	ISSI	IS32FL3738
LDO	U3	Reduced voltage	1	ST	LM317D2T
Diode	LD1~LD16	RGB LED, SMD	16	ROHM	SMLV56RGB1W1
Diode	D1,D2	Diode, SMD	2	DIODES	SS36
Resistor	R5	RES,200k,1/16W,±5%,SMD	1	Yageo	RC0603JR-07200KL
Resistor	R3,R8,R9,R10	RES,100k,1/16W,±5%,SMD	4	Yageo	RC0603JR-07100KL
Resistor	R1	RES,62k,1/16W,±5%,SMD	1	Yageo	RC0603JR-0762KL
Resistor	R4,R17,R18	RES,51k,1/16W,±5%,SMD	3	Yageo	RC0603JR-0751KL
Resistor	R14	RES,20k,1/16W,±5%,SMD	1	Yageo	RC0603JR-0720KL
Resistor	R2	RES,12k,1/16W,±5%,SMD	1	Yageo	RC0603JR-0712KL
Resistor	R11	RES,10k,1/16W,±5%,SMD	1	Yageo	RC0603JR-0710KL
Resistor	R6,R7	RES,4.7k,1/16W,±5%,SMD	2	Yageo	RC0603JR-074K7L
Resistor	R15	RES,390R,1/16W,±5%,SMD	1	Yageo	RC0603JR-07390RL
Resistor	R16	RES,120R,1/16W,±5%,SMD	1	Yageo	RC0603JR-07120RL
Resistor	R12	RES,0R,1/16W,±5%,SMD	1	Yageo	RC0603JR-070RL
Resistor	R13	NC	1		
Capacitor	C15	CAP,1µF,16V,±20%,SMD	1	Yageo	CC0603KKX7R9BB105
Capacitor	C7	CAP,330pF,16V,±20%,SMD	1	Yageo	CC0603KKX7R9BB331
Capacitor	C4,12	CAP,4.7µF,16V, ±20%,SMD	2	Yageo	CC0603KKX7R9BB476
Capacitor	C6,C7	CAP,33pF,16V,±20%,SMD	2	Yageo	CC0603KKX7R9BB330
Capacitor	C8,C9,C10	CAP,0.1µF,16V,±20%,SMD	3	Yageo	CC0603KKX7R9BB104
Button	K1	Button SMD	1		

## 6x8 MATRIX LED DRIVER

### BILL OF MATERIALS (Genuino Uno Part)

Name	Symbol	Description	Qty	Supplier	Part No.
MCU	U1	Microcontroller	1	ATM	ATMEGA32U4
LDO	U2	Reduced voltage	1	ON	NCP1117-5
LDO	U4	Reduced voltage	1	TI	LP2985-33DBVR
Triode	T1	FET	1	FAIRCHILD	FDN340P
Triode	T2	FET	1	NXP	PMV48XP
Crystal	Y1	Crystal, 16MHz	1	Risym	3225 16MHz
Button	K1	Button SMD	1	MT	SMD-KEY-5P
LED	ON,TX,RX	LED, SMD Blue	3	EVERLIGHT	0603
LED	L	LED, SMD Greed	1	EVERLIGHT	0603
F1	F1	SMD Fuse	1	MF	MSMF050-2
Beads	L2	Beads	1	BOURNS	RC0603JR-0712KL
Varistor	Z1,Z2	Varistor	2	BOURNS	CG0603MLC-05E
Resistor	R3,R10	RES,22R,1/16W,±5%,SMD	2	Yageo	RC0603JR-0722RL
Resistor	R5,R6,R7,R8	RES,1k,1/16W,±5%,SMD	4	Yageo	RC0603JR-071KL
Resistor	R1,R2,R4	RES,10k,1/16W,±5%,SMD	3	Yageo	RC0603JR-0710KL
Capacitor	C12,C13	CAP,22pF,16V,±20%,SMD	2	Yageo	CC0603KKX7R9BB22
Capacitor	C1,C2,C6, C9,C10,C11	CAP,100nF,16V,±20%,SMD	6	Yageo	CC0603KKX7R9BB101
Capacitor	C4,C5	CAP,1µF,16V, ±20%,SMD	2	Yageo	CC0603KKX7R9BB105
Capacitor	C3,C14	CAP,22µF,16V,±20%,SMD	2	Yageo	CC0603KKX7R9BB226
Diode	D2	Diode, SMD	1	BOURNS	CD1206-S01575

*Bill of Materials, refer to Figure 1 above.*

6x8 MATRIX LED DRIVER

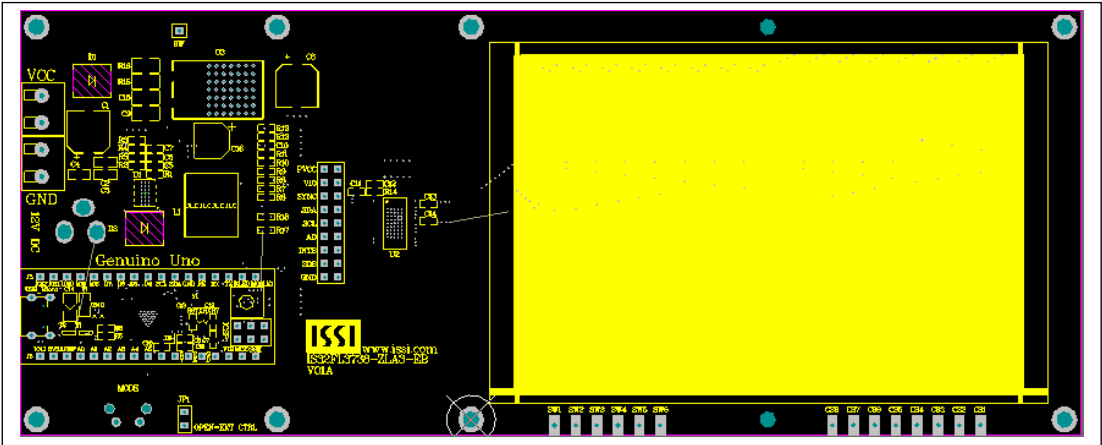

Figure 9: Board Component Placement Guide - Top Layer: V01A

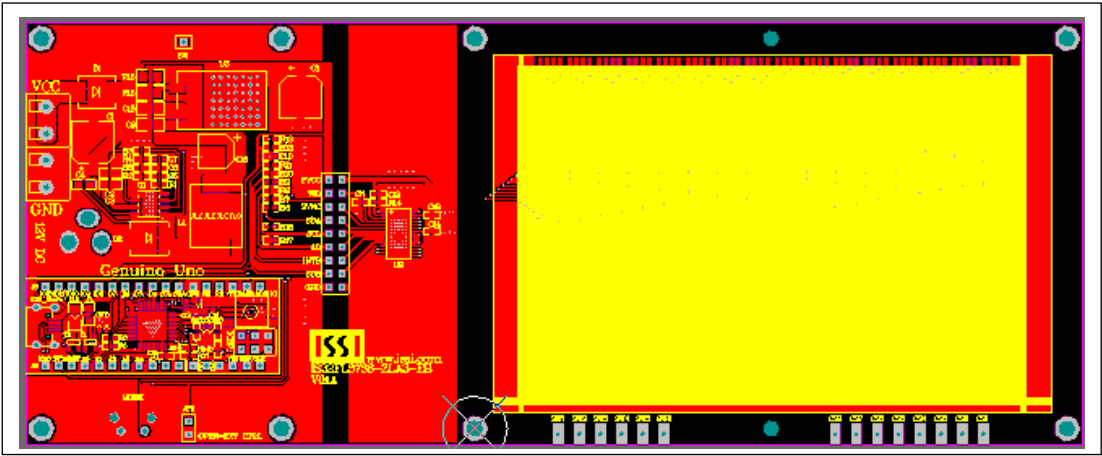

Figure 10: Board PCB Layout - Top Layer: V01A



Компания «Life Electronics» занимается поставками электронных компонентов импортного и отечественного производства от производителей и со складов крупных дистрибьюторов Европы, Америки и Азии.

С конца 2013 года компания активно расширяет линейку поставок компонентов по направлению коаксиальный кабель, кварцевые генераторы и конденсаторы (керамические, пленочные, электролитические), за счёт заключения дистрибьюторских договоров

Мы предлагаем:

- Конкурентоспособные цены и скидки постоянным клиентам.
- Специальные условия для постоянных клиентов.
- Подбор аналогов.
- Поставку компонентов в любых объемах, удовлетворяющих вашим потребностям.
- Приемлемые сроки поставки, возможна ускоренная поставка.
- Доставку товара в любую точку России и стран СНГ.
- Комплексную поставку.
- Работу по проектам и поставку образцов.
- Формирование склада под заказчика.
- Сертификаты соответствия на поставляемую продукцию (по желанию клиента).
- Тестирование поставляемой продукции.
- Поставку компонентов, требующих военную и космическую приемку.
- Входной контроль качества.
- Наличие сертификата ISO.

В составе нашей компании организован Конструкторский отдел, призванный помогать разработчикам, и инженерам.

Конструкторский отдел помогает осуществить:

- Регистрацию проекта у производителя компонентов.
- Техническую поддержку проекта.
- Защиту от снятия компонента с производства.
- Оценку стоимости проекта по компонентам.
- Изготовление тестовой платы монтаж и пусконаладочные работы.



Тел: +7 (812) 336 43 04 (многоканальный)

Email: [org@lifeelectronics.ru](mailto:org@lifeelectronics.ru)