

MC10EP142, MC100EP142

3.3 V / 5 V ECL 9-Bit Shift Register

The MC10EP/100EP142 is a 9-bit shift register, designed with byte-parity applications in mind. The MC10/100EP142 is capable of performing serial/parallel data into serial/parallel out and shifting in only one direction. The nine inputs D0 – D8 accept parallel input data, while S-IN accepts serial input data. The Q0:87 outputs do not need to be terminated for the shift operation to function. To minimize power, any Q output not used should be left unterminated.

The SEL (Select) input pin is used to switch between the two modes of operation – SHIFT and LOAD. The shift direction is from Bit 0 to Bit 8. Input data is accepted by the registers a set-up time before the positive going edge of CLK0 or CLK1; shifting is also accomplished on the positive clock edge. A HIGH on the Master Reset pin (MR) asynchronously resets all the registers to zero, overriding CLK0 and CLK1 inputs.

The 100 Series contains temperature compensation.

Features

- Shift Frequency >2.8 GHz (Typical)
- 9-Bit for Byte-Parity Applications
- Asynchronous Master Reset
- Dual Clocks
- PECL Mode Operating Range: $V_{CC} = 3.0\text{ V}$ to 5.5 V with $V_{EE} = 0\text{ V}$
- NECL Mode Operating Range: $V_{CC} = 0\text{ V}$ with $V_{EE} = -3.0\text{ V}$ to -5.5 V
- Open Input Default State
- Safety Clamp on Inputs
- Pb-Free Packages are Available



ON Semiconductor®

<http://onsemi.com>

MARKING DIAGRAM*



LQFP-32
FA SUFFIX
CASE 873A

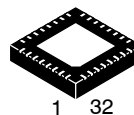
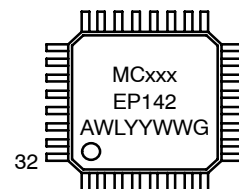

QFN32
MN SUFFIX
CASE 488AM



xxx = 10 or 100
A = Assembly Location
WL, L = Wafer Lot
YY, Y = Year
WW, W = Work Week
G or ■ = Pb-Free Package

(Note: Microdot may be in either location)

*For additional marking information, refer to Application Note AND8002/D.

ORDERING INFORMATION

See detailed ordering and shipping information in the package dimensions section on page 11 of this data sheet.

MC10EP142, MC100EP142

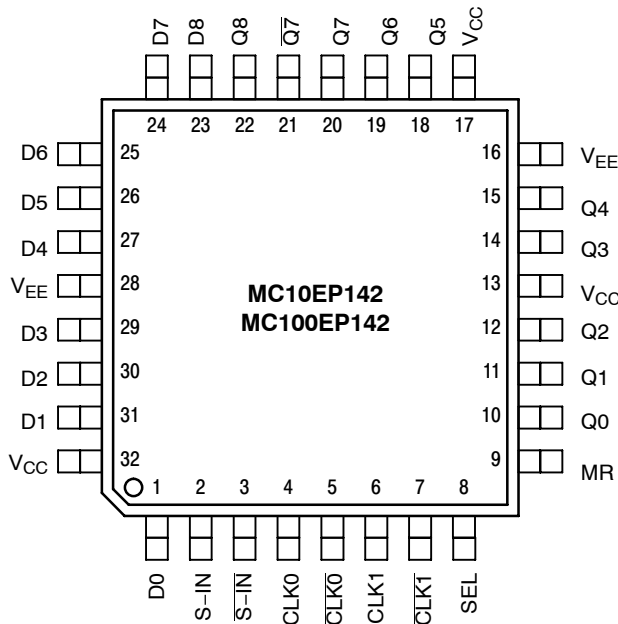

Figure 1. Pinout: LQFP-32 (Top View)

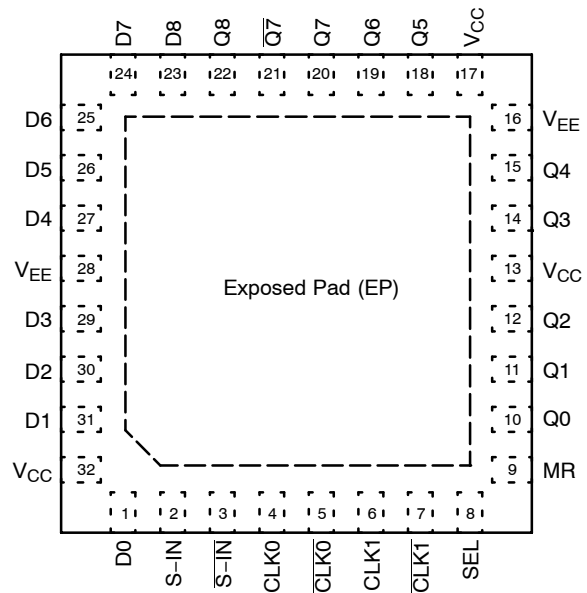

Figure 2. Pinout: QFN-32 (Top View)

Table 1. PIN DESCRIPTION

Pin	Name	I/O	Default State	Description
1,23,24,25,26,27,29,30,31	D[0:8]	ECL Input	Low	Single-Ended Parallel Data Inputs [0:8]. Internal 75 kΩ to V _{EE} .
2	S-IN	ECL Input	Low	Noninverted Differential Serial Input. Internal 75 kΩ to V _{EE} .
3	$\overline{S-IN}$	ECL Input	High	Inverted Differential Serial Input. Internal 75 kΩ to V _{EE} and 36.5 kΩ to V _{CC} .
4	CLK0	ECL Input	Low	Noninverted Differential CLK0 Input. Internal 75 kΩ to V _{EE} .
5	$\overline{CLK0}$	ECL Input	High	Inverted Differential CLK0B Input. Internal 75 kΩ to V _{EE} and 36.5 kΩ to V _{CC} .
6	CLK1	ECL Input	Low	Noninverted Differential CLK1 Input. Internal 75 kΩ to V _{EE} .
7	$\overline{CLK1}$	ECL Input	High	Inverted Differential CLK1B Input. Internal 75 kΩ to V _{EE} and 36.5 kΩ to V _{CC} .
8	SEL	ECL Input	Low	Single-Ended Select Logic Input. Internal 75 kΩ to V _{EE} .
9	MR	ECL Input	Low	Single-Ended Master Reset Logic Input. Internal 75 kΩ to V _{EE} .
10,11,12,14,15,18,19,22	Q0,Q1,Q2,Q3,Q4,Q5,Q6,Q8	ECL Output	-	Single-Ended parallel Data outputs [0,1,2,3,4,5,6,8]. Typically Terminated with 50 Ω to V _{TT} = V _{CC} - 2 V.
13,17,32	V _{CC}	-	-	Positive supply Voltage. All V _{CC} Pins must be Externally Connected to Power Supply to Guarantee Proper Operation.
16,28	V _{EE}	-	-	Negative supply Voltage. All V _{EE} Pins must be Externally connected to Power Supply to Guarantee Proper Operation.
20	Q7	ECL Output	-	Noninverted Differential parallel/Serial Data Output 7. Typically Terminated with 50 Ω to V _{TT} = V _{CC} - 2 V.
21	$\overline{Q7}$	ECL Output	-	Inverted Differential parallel/Serial Data Output 7. Typically Terminated with 50 Ω to V _{TT} = V _{CC} - 2 V.

1. All V_{CC} and V_{EE} pins must be externally connected to Power Supply to guarantee proper operation.

MC10EP142, MC100EP142

Table 2. TRUTH TABLE

Function (Note 2)	SEL	S-IN	MR	CLK0	CLK1	Q0	Q1	Q2	Q3	Q4	Q5	Q6	Q7	Q8	Q9
Load	L	X	L	Z	Z	D0	D1	D2	D3	D4	D5	D6	D7	D8	D9
Shift	H	L	L	Z	Z	L	Q0	Q1	Q2	Q3	Q4	Q5	Q6	Q7	Q8
	H	H	L	Z	Z	H	Q0	Q1	Q2	Q3	Q4	Q5	Q6	Q7	Q8
Reset	X	X	H	Z	Z	L	L	L	L	L	L	L	L	L	L

2. All Load and Shift functions are accomplished on the positive edge of CLK0 or CLK1.

MC10EP142, MC100EP142

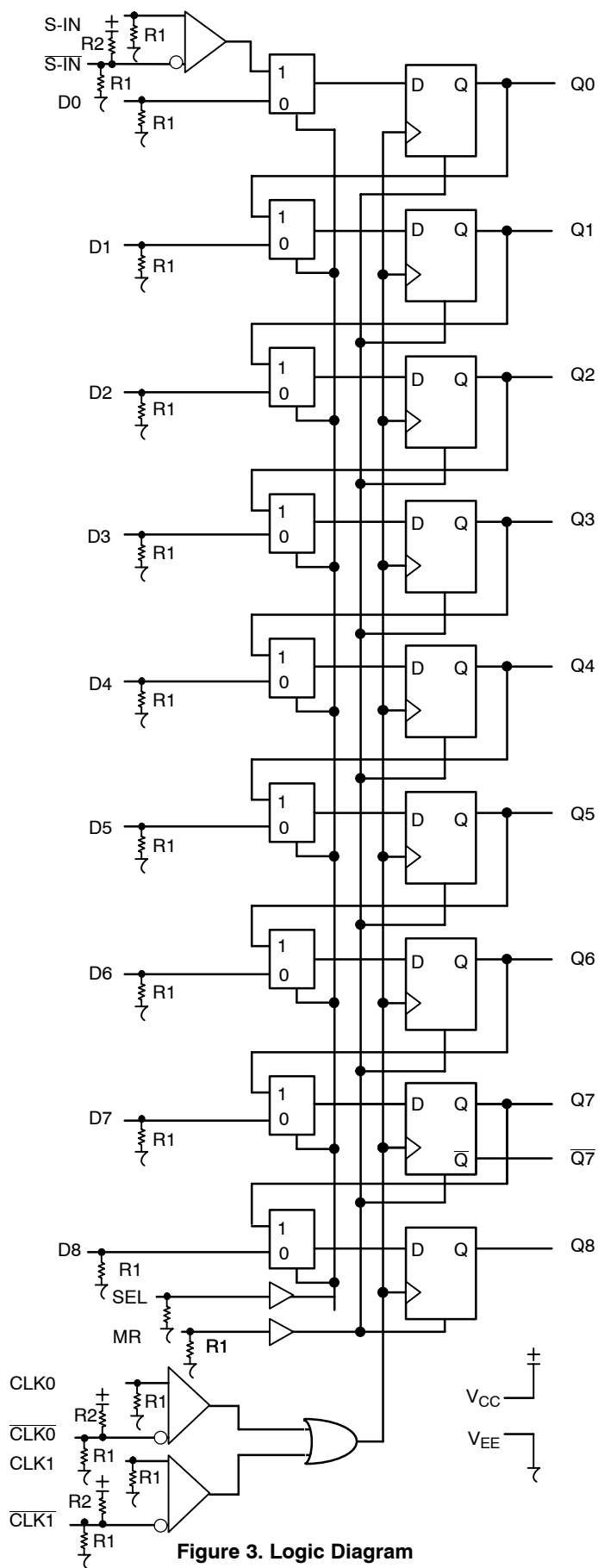

Figure 3. Logic Diagram

MC10EP142, MC100EP142

Table 3. ATTRIBUTES

Characteristics		Value
Internal Input Pulldown Resistor	(R1)	75 k Ω
Internal Input Pullup Resistor	(R2)	37.5 k Ω
ESD Protection	Human Body Model Machine Model Charged Device Model	> 2 kV > 100 V > 2 kV
Moisture Sensitivity (Note 3)	LQFP QFN	Level 2 Level 1
Flammability Rating	Oxygen Index: 28 to 34	UL-94 V-0 @ 0.125 in
Transistor Count		405 Devices
Meets or exceeds JEDEC Spec EIA/JESD78 IC Latchup Test		

3. For additional information, refer to Application Note AND8003/D.

Table 4. MAXIMUM RATINGS

Symbol	Parameter	Condition 1	Condition 2	Rating	Unit
V _{CC}	Positive Power Supply	V _{EE} = 0 V		8	V
V _{EE}	Negative Power Supply	V _{CC} = 0 V		-8	V
V _I	PECL Mode Input Voltage NECL Mode Input Voltage	V _{EE} = 0 V V _{CC} = 0 V	V _I \leq V _{CC} V _I \geq V _{EE}	6 -6	V
I _{out}	Output Current	Continuous Surge		50 100	mA
T _A	Operating Temperature Range			-40 to +85	$^{\circ}$ C
T _{stg}	Storage Temperature Range			-65 to +150	$^{\circ}$ C
θ_{JA}	Thermal Resistance (Junction-to-Ambient)	0 lfpm 500 lfpm	LQFP-32 LQFP-32	80 55	$^{\circ}$ C/W
θ_{JC}	Thermal Resistance (Junction-to-Case)	Standard Board	LQFP-32	12 to 17	$^{\circ}$ C/W
θ_{JA}	Thermal Resistance (Junction-to-Ambient)	0 lfpm 500 lfpm	QFN-32 QFN-32	31 27	$^{\circ}$ C/W
θ_{JC}	Thermal Resistance (Junction-to-Case)	2S2P	QFN-32	12	$^{\circ}$ C/W
T _{sol}	Wave Solder	Pb \leq 3 sec @ 248 $^{\circ}$ C Pb-Free \leq 3 sec @ 260 $^{\circ}$ C		265 265	$^{\circ}$ C

Stresses exceeding Maximum Ratings may damage the device. Maximum Ratings are stress ratings only. Functional operation above the Recommended Operating Conditions is not implied. Extended exposure to stresses above the Recommended Operating Conditions may affect device reliability.

MC10EP142, MC100EP142

Table 5. 10EP DC CHARACTERISTICS, PECL $V_{CC} = 3.3\text{ V}$, $V_{EE} = 0\text{ V}$ (Note 4)

Symbol	Characteristic	-40°C			25°C			85°C			Unit
		Min	Typ	Max	Min	Typ	Max	Min	Typ	Max	
I_{EE}	Negative Power Supply Current	105	125	145	105	125	145	105	125	145	mA
V_{OH}	Output HIGH Voltage (Note 5)	2165	2290	2415	2230	2355	2480	2290	2415	2540	mV
V_{OL}	Output LOW Voltage (Note 5)	1365	1490	1615	1430	1555	1680	1490	1615	1740	mV
V_{IH}	Input HIGH Voltage (Single-Ended)	2090		2415	2155		2480	2215		2540	mV
V_{IL}	Input LOW Voltage (Single-Ended)	1365		1690	1460		1755	1490		1815	mV
V_{IHCMR}	Input HIGH Voltage Common Mode Range (Differential Configuration) (Note 6)	2.0		3.3	2.0		3.3	2.0		3.3	V
I_{IH}	Input HIGH Current (@ V_{IH})			150			150			150	μA
I_{IL}	Input LOW Current (@ V_{IL}) CLK0, CLK1, D, S-IN CLK0, CLK1, S-IN	0.5 -150			0.5 -150			0.5 -150			μA

NOTE: Device will meet the specifications after thermal equilibrium has been established when mounted in a test socket or printed circuit board with maintained transverse airflow greater than 500 lfm. Electrical parameters are guaranteed only over the declared operating temperature range. Functional operation of the device exceeding these conditions is not implied. Device specification limit values are applied individually under normal operating conditions and not valid simultaneously.

4. Input and output parameters vary 1:1 with V_{CC} . V_{EE} can vary +0.3 V to -2.2 V.

5. All loading with 50 Ω to $V_{CC} - 2.0\text{ V}$.

6. V_{IHCMR} min varies 1:1 with V_{EE} . V_{IHCMR} max varies 1:1 with V_{CC} . The V_{IHCMR} range is referenced to the most positive side of the differential input signal.

Table 6. 10EP DC CHARACTERISTICS, PECL $V_{CC} = 5.0\text{ V}$, $V_{EE} = 0\text{ V}$ (Note 7)

Symbol	Characteristic	-40°C			25°C			85°C			Unit
		Min	Typ	Max	Min	Typ	Max	Min	Typ	Max	
I_{EE}	Negative Power Supply Current (Note 8)	105	125	145	105	125	145	105	125	145	mA
V_{OH}	Output HIGH Voltage (Note 9)	3865	3990	4115	3930	4055	4180	3990	4115	4240	mV
V_{OL}	Output LOW Voltage (Note 9)	3065	3190	3315	3130	3255	3380	3190	3315	3440	mV
V_{IH}	Input HIGH Voltage (Single-Ended)	3790		4115	3855		4180	3915		4240	mV
V_{IL}	Input LOW Voltage (Single-Ended)	3065		3390	3130		3455	3190		3515	mV
V_{IHCMR}	Input HIGH Voltage Common Mode Range (Differential Configuration) (Note 10)	2.0		5.0	2.0		5.0	2.0		5.0	V
I_{IH}	Input HIGH Current (@ V_{IH})			150			150			150	μA
I_{IL}	Input LOW Current (@ V_{IL}) CLK0, CLK1, D, S-IN CLK0, CLK1, S-IN	0.5 -150			0.5 -150			0.5 -150			μA

NOTE: Device will meet the specifications after thermal equilibrium has been established when mounted in a test socket or printed circuit board with maintained transverse airflow greater than 500 lfm. Electrical parameters are guaranteed only over the declared operating temperature range. Functional operation of the device exceeding these conditions is not implied. Device specification limit values are applied individually under normal operating conditions and not valid simultaneously.

7. Input and output parameters vary 1:1 with V_{CC} . V_{EE} can vary +2.0 V to -0.5 V.

8. Required 500 lfm air flow when using +5 V power supply. For $(V_{CC} - V_{EE}) > 3.3\text{ V}$, 5 Ω to 10 Ω in line with V_{EE} required for maximum thermal protection at elevated temperatures. Recommend $V_{CC} - V_{EE}$ operation at $\leq 3.3\text{ V}$.

9. All loading with 50 Ω to $V_{CC} - 2.0\text{ V}$.

10. V_{IHCMR} min varies 1:1 with V_{EE} . V_{IHCMR} max varies 1:1 with V_{CC} . The V_{IHCMR} range is referenced to the most positive side of the differential input signal.

MC10EP142, MC100EP142

Table 7. 10EP DC CHARACTERISTICS, NECL $V_{CC} = 0\text{ V}$, $V_{EE} = -5.5\text{ V}$ to -3.0 V (Note 11)

Symbol	Characteristic	-40°C			25°C			85°C			Unit
		Min	Typ	Max	Min	Typ	Max	Min	Typ	Max	
I_{EE}	Negative Power Supply Current (Note 12)	105	125	145	105	125	145	105	125	145	mA
V_{OH}	Output HIGH Voltage (Note 13)	-1135	-1010	-885	-1070	-945	-820	-1010	-885	-760	mV
V_{OL}	Output LOW Voltage (Note 13)	-1935	-1810	-1685	-1870	-1745	-1620	-1810	-1685	-1560	mV
V_{IH}	Input HIGH Voltage (Single-Ended)	-1210		-885	-1145		-820	-1085		-760	mV
V_{IL}	Input LOW Voltage (Single-Ended)	-1935		-1610	-1870		-1545	-1810		-1485	mV
V_{IHCMR}	Input HIGH Voltage Common Mode Range (Differential Configuration) (Note 14)	$V_{EE}+2.0$		0.0	$V_{EE}+2.0$		0.0	$V_{EE}+2.0$		0.0	V
I_{IH}	Input HIGH Current (@ V_{IH})			150			150			150	μA
I_{IL}	Input LOW Current (@ V_{IL}) CLK0, CLK1, D, S-IN CLK0, CLK1, S-IN	0.5 -150			0.5 -150			0.5 -150			μA

NOTE: Device will meet the specifications after thermal equilibrium has been established when mounted in a test socket or printed circuit board with maintained transverse airflow greater than 500 lfm. Electrical parameters are guaranteed only over the declared operating temperature range. Functional operation of the device exceeding these conditions is not implied. Device specification limit values are applied individually under normal operating conditions and not valid simultaneously.

11. Input and output parameters vary 1:1 with V_{CC} .

12. Required 500 lfm air flow when using -5 V power supply. For $(V_{CC} - V_{EE}) > 3.3\text{ V}$, $5\ \Omega$ to $10\ \Omega$ in line with V_{EE} required for maximum thermal protection at elevated temperatures. Recommend $V_{CC}-V_{EE}$ operation at $\leq 3.3\text{ V}$.

13. All loading with $50\ \Omega$ to $V_{CC} - 2.0\text{ V}$.

14. V_{IHCMR} min varies 1:1 with V_{EE} . V_{IHCMR} max varies 1:1 with V_{CC} . The V_{IHCMR} range is referenced to the most positive side of the differential input signal.

Table 8. 100EP DC CHARACTERISTICS, PECL $V_{CC} = 3.3\text{ V}$, $V_{EE} = 0\text{ V}$ (Note 15)

Symbol	Characteristic	-40°C			25°C			85°C			Unit
		Min	Typ	Max	Min	Typ	Max	Min	Typ	Max	
I_{EE}	Negative Power Supply Current	105	125	145	105	130	150	105	130	150	mA
V_{OH}	Output HIGH Voltage (Note 16)	2155	2280	2405	2155	2280	2405	2155	2280	2405	mV
V_{OL}	Output LOW Voltage (Note 16)	1355	1480	1605	1355	1480	1605	1355	1480	1605	mV
V_{IH}	Input HIGH Voltage (Single-Ended)	2075		2420	2075		2420	2075		2420	mV
V_{IL}	Input LOW Voltage (Single-Ended)	1355		1675	1355		1675	1355		1675	mV
V_{IHCMR}	Input HIGH Voltage Common Mode Range (Differential Configuration) (Note 17)	2.0		3.3	2.0		3.3	2.0		3.3	V
I_{IH}	Input HIGH Current (@ V_{IH})			150			150			150	μA
I_{IL}	Input LOW Current (@ V_{IL}) CLK0, CLK1, D, S-IN CLK0, CLK1, S-IN	0.5 -150			0.5 -150			0.5 -150			μA

NOTE: Device will meet the specifications after thermal equilibrium has been established when mounted in a test socket or printed circuit board with maintained transverse airflow greater than 500 lfm. Electrical parameters are guaranteed only over the declared operating temperature range. Functional operation of the device exceeding these conditions is not implied. Device specification limit values are applied individually under normal operating conditions and not valid simultaneously.

15. Input and output parameters vary 1:1 with V_{CC} . V_{EE} can vary +0.3 V to -2.2 V.

16. All loading with $50\ \Omega$ to $V_{CC} - 2.0\text{ V}$.

17. V_{IHCMR} min varies 1:1 with V_{EE} . V_{IHCMR} max varies 1:1 with V_{CC} . The V_{IHCMR} range is referenced to the most positive side of the differential input signal.

MC10EP142, MC100EP142

Table 9. 100EP DC CHARACTERISTICS, PECL $V_{CC} = 5.0\text{ V}$, $V_{EE} = 0\text{ V}$ (Note 18)

Symbol	Characteristic	-40°C			25°C			85°C			Unit
		Min	Typ	Max	Min	Typ	Max	Min	Typ	Max	
I_{EE}	Negative Power Supply Current (Note 19)	105	125	145	105	130	150	105	130	150	mA
V_{OH}	Output HIGH Voltage (Note 20)	3855	3980	4105	3855	3980	4105	3855	3980	4105	mV
V_{OL}	Output LOW Voltage (Note 20)	3055	3180	3305	3055	3180	3305	3055	3180	3305	mV
V_{IH}	Input HIGH Voltage (Single-Ended)	3775		4120	3775		4120	3775		4120	mV
V_{IL}	Input LOW Voltage (Single-Ended)	3055		3375	3055		3375	3055		3375	mV
V_{IHCMR}	Input HIGH Voltage Common Mode Range (Differential Configuration) (Note 21)	2.0		5.0	2.0		5.0	2.0		5.0	V
I_{IH}	Input HIGH Current (@ V_{IH})			150			150			150	μA
I_{IL}	Input LOW Current (@ V_{IL}) CLK0, CLK1, D, S-IN CLK0, CLK1, S-IN	0.5 -150			0.5 -150			0.5 -150			μA

NOTE: Device will meet the specifications after thermal equilibrium has been established when mounted in a test socket or printed circuit board with maintained transverse airflow greater than 500 lfm. Electrical parameters are guaranteed only over the declared operating temperature range. Functional operation of the device exceeding these conditions is not implied. Device specification limit values are applied individually under normal operating conditions and not valid simultaneously.

18. Input and output parameters vary 1:1 with V_{CC} . V_{EE} can vary +2.0 V to -0.5 V.

19. Required 500 lfm air flow when using +5 V power supply. For $(V_{CC} - V_{EE}) > 3.3\text{ V}$, $5\ \Omega$ to $10\ \Omega$ in line with V_{EE} required for maximum thermal protection at elevated temperatures. Recommend $V_{CC} - V_{EE}$ operation at $\leq 3.3\text{ V}$.

20. All loading with $50\ \Omega$ to $V_{CC} - 2.0\text{ V}$.

21. V_{IHCMR} min varies 1:1 with V_{EE} . V_{IHCMR} max varies 1:1 with V_{CC} . The V_{IHCMR} range is referenced to the most positive side of the differential input signal.

Table 10. 100EP DC CHARACTERISTICS, NECL $V_{CC} = 0\text{ V}$, $V_{EE} = -5.5\text{ V}$ to -3.0 V (Note 22)

Symbol	Characteristic	-40°C			25°C			85°C			Unit
		Min	Typ	Max	Min	Typ	Max	Min	Typ	Max	
I_{EE}	Negative Power Supply Current (Note 23)	105	125	145	105	130	150	105	130	150	mA
V_{OH}	Output HIGH Voltage (Note 24)	-1145	-1020	-895	-1145	-1020	-895	-1145	-1020	-895	mV
V_{OL}	Output LOW Voltage (Note 24)	-1945	-1820	-1695	-1945	-1820	-1695	-1945	-1820	-1695	mV
V_{IH}	Input HIGH Voltage (Single-Ended)	-1225		-880	-1225		-880	-1225		-880	mV
V_{IL}	Input LOW Voltage (Single-Ended)	-1945		-1625	-1945		-1625	-1945		-1625	mV
V_{IHCMR}	Input HIGH Voltage Common Mode Range (Differential Configuration) (Note 25)	$V_{EE} + 2.0$		0.0	$V_{EE} + 2.0$		0.0	$V_{EE} + 2.0$		0.0	V
I_{IH}	Input HIGH Current (@ V_{IH})			150			150			150	μA
I_{IL}	Input LOW Current (@ V_{IL}) CLK0, CLK1, D, S-IN CLK0, CLK1, S-IN	0.5 -150			0.5 -150			0.5 -150			μA

NOTE: Device will meet the specifications after thermal equilibrium has been established when mounted in a test socket or printed circuit board with maintained transverse airflow greater than 500 lfm. Electrical parameters are guaranteed only over the declared operating temperature range. Functional operation of the device exceeding these conditions is not implied. Device specification limit values are applied individually under normal operating conditions and not valid simultaneously.

22. Input and output parameters vary 1:1 with V_{CC} .

23. Required 500 lfm air flow when using -5 V power supply. For $(V_{CC} - V_{EE}) > 3.3\text{ V}$, $5\ \Omega$ to $10\ \Omega$ in line with V_{EE} required for maximum thermal protection at elevated temperatures. Recommend $V_{CC} - V_{EE}$ operation at $\leq 3.3\text{ V}$.

24. All loading with $50\ \Omega$ to $V_{CC} - 2.0\text{ V}$.

25. V_{IHCMR} min varies 1:1 with V_{EE} . V_{IHCMR} max varies 1:1 with V_{CC} . The V_{IHCMR} range is referenced to the most positive side of the differential input signal.

MC10EP142, MC100EP142

Table 11. AC CHARACTERISTICS $V_{CC} = 3.0\text{ V to }5.5\text{ V}$; $V_{EE} = 0.0\text{ V or }V_{CC} = 0.0\text{ V}$; $V_{EE} = -3.0\text{ V to }-5.5\text{ V}$ (Note 26)

Symbol	Characteristic	-40°C			25°C			85°C			Unit
		Min	Typ	Max	Min	Typ	Max	Min	Typ	Max	
f_{SHIFT}	Maximum Shift Frequency					2.8					GHz
t_{PLH} , t_{PHL}	Propagation Delay to Output CLKx MR	500 500	625 625	750 750	550 550	675 675	800 800	575 575	700 700	825 825	ps
t_s	Setup Time D SEL	50 100	-50 50		50 100	-50 50		50 100	-50 50		ps
t_h	Hold Time D SEL	100 50	50 -50		100 50	50 -50		100 50	50 -50		ps
t_{RR}	Reset Recovery Time					800					ps
t_{pw}	Minimum Pulse Width					200					ps
t_{SKEW}	Within-Device Skew (Note 27) Duty Cycle Skew (Note 28) Q, \bar{Q}		50 5.0	100 20		50 5.0	100 20		50 5.0	100 20	ps
t_{JITTER}	Random Clock Jitter (Figure 4)		1	2		1	2		1	2	ps
V_{inpp}	Input Voltage Swing/Sensitivity (Differential Configuration)	150	800	1200	150	800	1200	150	800	1200	mV
t_r , t_f	Rise/Fall Times @ 50 MHz (20 - 80%)	110	180	250	125	190	275	150	215	300	ps

NOTE: Device will meet the specifications after thermal equilibrium has been established when mounted in a test socket or printed circuit board with maintained transverse airflow greater than 500 lfpm. Electrical parameters are guaranteed only over the declared operating temperature range. Functional operation of the device exceeding these conditions is not implied. Device specification limit values are applied individually under normal operating conditions and not valid simultaneously.

26. Measured using a 750 mV source, 50% duty cycle clock source. All loading with 50 Ω to $V_{CC} - 2.0\text{ V}$.

27. Within-device skew is defined as identical transitions on similar paths through a device.

28. Skew is measured between outputs under identical transitions. Duty cycle skew is defined only for differential operation when the delays are measured from the cross point of the inputs to the cross point of the outputs.

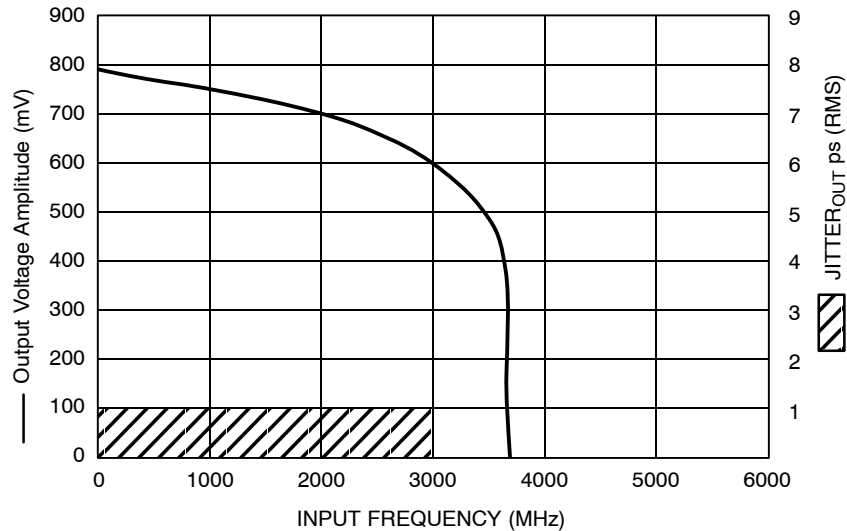

Figure 4. Output Voltage Amplitude / RMS Jitter vs. Input Frequency at Ambient Temperature (Typical)

MC10EP142, MC100EP142

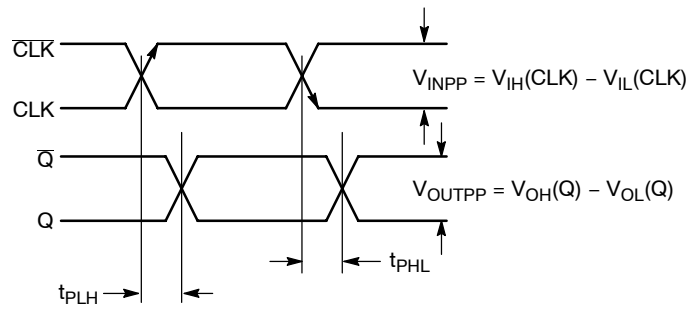
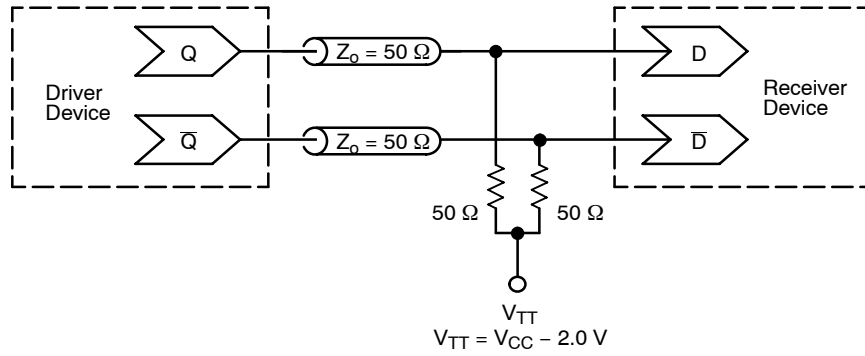

Figure 5. AC Reference Measurement



**Figure 6. Typical Termination for Output Driver and Device Evaluation
(See Application Note AND8020/D – Termination of ECL Logic Devices.)**

MC10EP142, MC100EP142

ORDERING INFORMATION

Device	Package	Shipping [†]
MC10EP142FA	LQFP-32	250 Units / Tray
MC10EP142FAG	LQFP-32 (Pb-Free)	250 Units / Tray
MC10EP142FAR2	LQFP-32	2000 / Tape & Reel
MC10EP142FAR2G	LQFP-32 (Pb-Free)	2000 / Tape & Reel
MC10EP142MNG	QFN-32 (Pb-Free)	74 Units / Rail
MC10EP142MNR4G	QFN-32 (Pb-Free)	1000 / Tape & Reel
MC100EP142FA	LQFP-32	250 Units / Tray
MC100EP142FAG	LQFP-32 (Pb-Free)	250 Units / Tray
MC100EP142FAR2	LQFP-32	2000 / Tape & Reel
MC100EP142FAR2G	LQFP-32 (Pb-Free)	2000 / Tape & Reel
MC100EP142MNG	QFN-32 (Pb-Free)	74 Units / Rail
MC100EP142MNR4G	QFN-32 (Pb-Free)	1000 / Tape & Reel

[†]For information on tape and reel specifications, including part orientation and tape sizes, please refer to our Tape and Reel Packaging Specifications Brochure, BRD8011/D.

Resource Reference of Application Notes

- AN1405/D** - ECL Clock Distribution Techniques
- AN1406/D** - Designing with PECL (ECL at +5.0 V)
- AN1503/D** - ECLinPS™ I/O SPICE Modeling Kit
- AN1504/D** - Metastability and the ECLinPS Family
- AN1568/D** - Interfacing Between LVDS and ECL
- AN1672/D** - The ECL Translator Guide
- AND8001/D** - Odd Number Counters Design
- AND8002/D** - Marking and Date Codes
- AND8020/D** - Termination of ECL Logic Devices
- AND8066/D** - Interfacing with ECLinPS
- AND8090/D** - AC Characteristics of ECL Devices

MC10EP142, MC100EP142

PACKAGE DIMENSIONS

32 LEAD LQFP
CASE 873A-02
ISSUE C

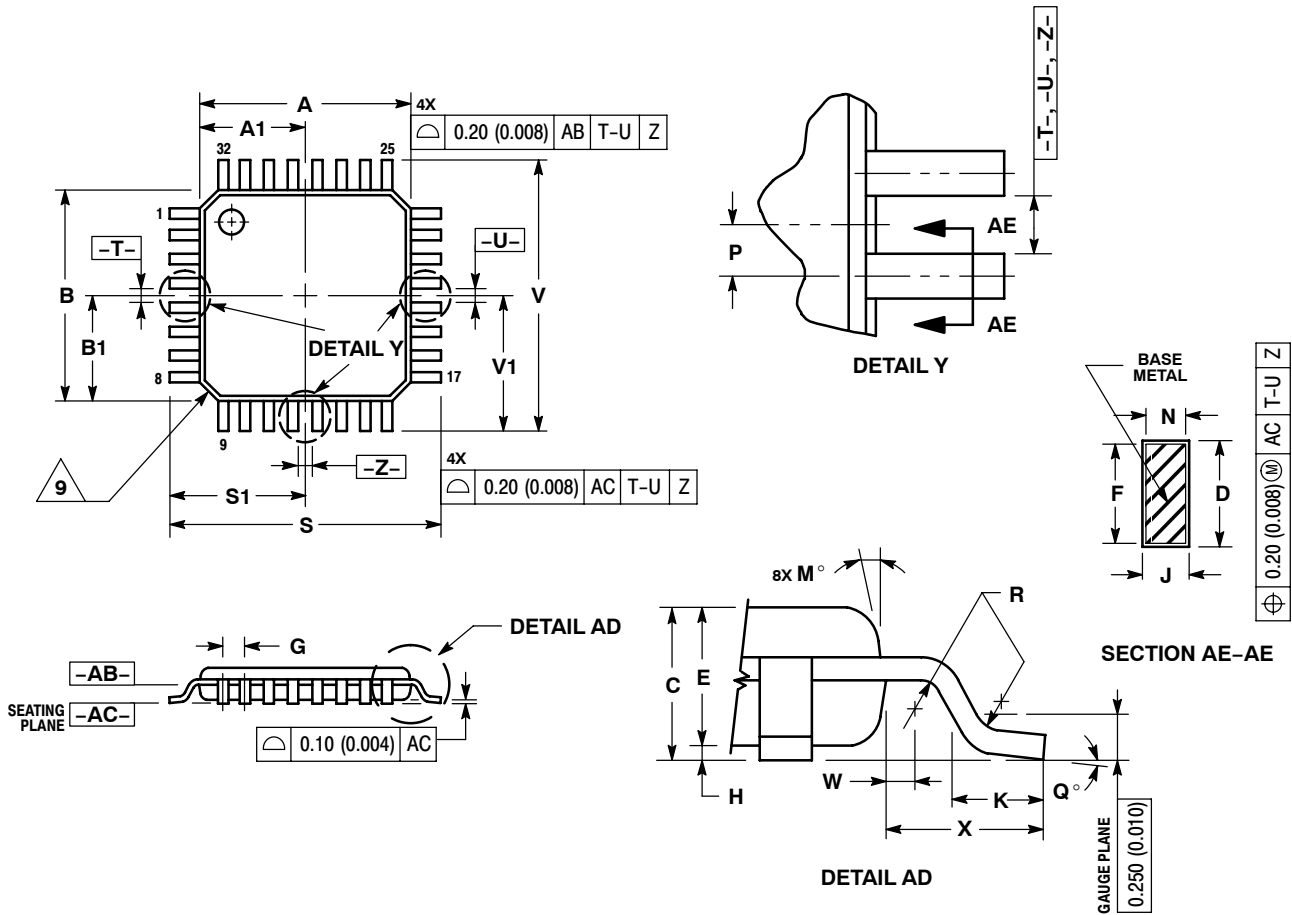

NOTES:

- DIMENSIONING AND TOLERANCING PER ANSI Y14.5M, 1982.
- CONTROLLING DIMENSION: MILLIMETER.
- DATUM PLANE -AB- IS LOCATED AT BOTTOM OF LEAD AND IS COINCIDENT WITH THE LEAD WHERE THE LEAD EXITS THE PLASTIC BODY AT THE BOTTOM OF THE PARTING LINE.
- DATUMS -T-, -U-, AND -Z- TO BE DETERMINED AT DATUM PLANE -AB-.
- DIMENSIONS S AND V TO BE DETERMINED AT SEATING PLANE -AC-.
- DIMENSIONS A AND B DO NOT INCLUDE MOLD PROTRUSION. ALLOWABLE PROTRUSION IS 0.250 (0.010) PER SIDE. DIMENSIONS A AND B DO INCLUDE MOLD MISMATCH AND ARE DETERMINED AT DATUM PLANE -AB-.
- DIMENSION D DOES NOT INCLUDE DAMBAR PROTRUSION. DAMBAR PROTRUSION SHALL NOT CAUSE THE D DIMENSION TO EXCEED 0.520 (0.020).
- MINIMUM SOLDER PLATE THICKNESS SHALL BE 0.0076 (0.0003).
- EXACT SHAPE OF EACH CORNER MAY VARY FROM DEPICTION.

MC10EP142, MC100EP142

PACKAGE DIMENSIONS

QFN32 5*5*1 0.5 P
CASE 488AM-01
ISSUE O

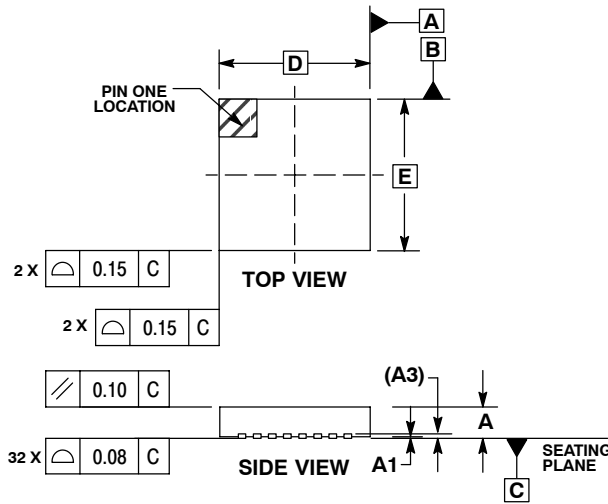

NOTES:

1. DIMENSIONS AND TOLERANCING PER ASME Y14.5M, 1994.
2. CONTROLLING DIMENSION: MILLIMETERS.
3. DIMENSION b APPLIES TO PLATED TERMINAL AND IS MEASURED BETWEEN 0.25 AND 0.30 MM TERMINAL
4. COPLANARITY APPLIES TO THE EXPOSED PAD AS WELL AS THE TERMINALS.

DIM	MILLIMETERS		
	MIN	NOM	MAX
A	0.800	0.900	1.000
A1	0.000	0.025	0.050
A3	0.200 REF		
b	0.180	0.250	0.300
D	5.00 BSC		
D2	2.950	3.100	3.250
E	5.00 BSC		
E2	2.950	3.100	3.250
e	0.500 BSC		
K	0.200	---	---
L	0.300	0.400	0.500

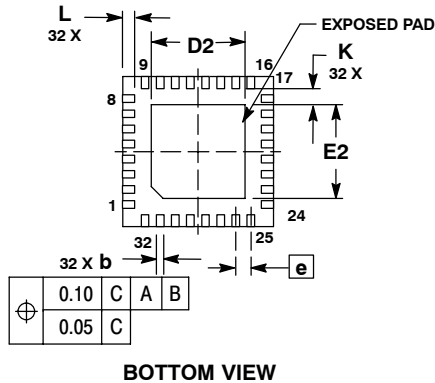

SOLDERING FOOTPRINT*

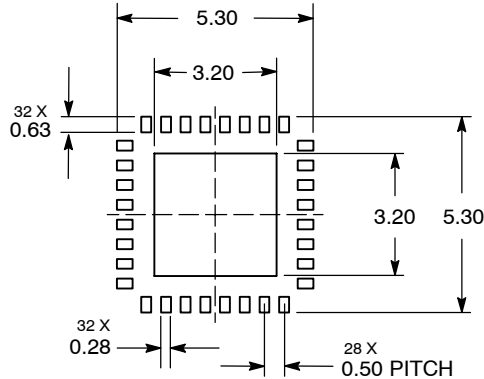

*For additional information on our Pb-Free strategy and soldering details, please download the ON Semiconductor Soldering and Mounting Techniques Reference Manual, SOLDERRM/D.

ECLinPS is a trademark of Semiconductor Components Industries, LLC (SCILLC)

ON Semiconductor and are registered trademarks of Semiconductor Components Industries, LLC (SCILLC). SCILLC reserves the right to make changes without further notice to any products herein. SCILLC makes no warranty, representation or guarantee regarding the suitability of its products for any particular purpose, nor does SCILLC assume any liability arising out of the application or use of any product or circuit, and specifically disclaims any and all liability, including without limitation special, consequential or incidental damages. "Typical" parameters which may be provided in SCILLC data sheets and/or specifications can and do vary in different applications and actual performance may vary over time. All operating parameters, including "Typicals" must be validated for each customer application by customer's technical experts. SCILLC does not convey any license under its patent rights nor the rights of others. SCILLC products are not designed, intended, or authorized for use as components in systems intended for surgical implant into the body, or other applications intended to support or sustain life, or for any other application in which the failure of the SCILLC product could create a situation where personal injury or death may occur. Should Buyer purchase or use SCILLC products for any such unintended or unauthorized application, Buyer shall indemnify and hold SCILLC and its officers, employees, subsidiaries, affiliates, and distributors harmless against all claims, costs, damages, and expenses, and reasonable attorney fees arising out of, directly or indirectly, any claim of personal injury or death associated with such unintended or unauthorized use, even if such claim alleges that SCILLC was negligent regarding the design or manufacture of the part. SCILLC is an Equal Opportunity/Affirmative Action Employer. This literature is subject to all applicable copyright laws and is not for resale in any manner.

PUBLICATION ORDERING INFORMATION

LITERATURE FULFILLMENT:
Literature Distribution Center for ON Semiconductor
P.O. Box 5163, Denver, Colorado 80217 USA
Phone: 303-675-2175 or 800-344-3860 Toll Free USA/Canada
Fax: 303-675-2176 or 800-344-3867 Toll Free USA/Canada
Email: orderlit@onsemi.com

N. American Technical Support: 800-282-9855 Toll Free USA/Canada
Europe, Middle East and Africa Technical Support:
Phone: 421 33 790 2910
Japan Customer Focus Center
Phone: 81-3-5773-3850

ON Semiconductor Website: www.onsemi.com
Order Literature: <http://www.onsemi.com/orderlit>

For additional information, please contact your local Sales Representative

Компания «Life Electronics» занимается поставками электронных компонентов импортного и отечественного производства от производителей и со складов крупных дистрибьюторов Европы, Америки и Азии.

С конца 2013 года компания активно расширяет линейку поставок компонентов по направлению коаксиальный кабель, кварцевые генераторы и конденсаторы (керамические, пленочные, электролитические), за счёт заключения дистрибьюторских договоров

Мы предлагаем:

- Конкурентоспособные цены и скидки постоянным клиентам.
- Специальные условия для постоянных клиентов.
- Подбор аналогов.
- Поставку компонентов в любых объемах, удовлетворяющих вашим потребностям.
- Приемлемые сроки поставки, возможна ускоренная поставка.
- Доставку товара в любую точку России и стран СНГ.
- Комплексную поставку.
- Работу по проектам и поставку образцов.
- Формирование склада под заказчика.
- Сертификаты соответствия на поставляемую продукцию (по желанию клиента).
- Тестирование поставляемой продукции.
- Поставку компонентов, требующих военную и космическую приемку.
- Входной контроль качества.
- Наличие сертификата ISO.

В составе нашей компании организован Конструкторский отдел, призванный помогать разработчикам, и инженерам.

Конструкторский отдел помогает осуществить:

- Регистрацию проекта у производителя компонентов.
- Техническую поддержку проекта.
- Защиту от снятия компонента с производства.
- Оценку стоимости проекта по компонентам.
- Изготовление тестовой платы монтаж и пусконаладочные работы.



Тел: +7 (812) 336 43 04 (многоканальный)

Email: org@lifeelectronics.ru

www.lifeelectronics.ru