

# 20W RX DUAL MODE WIRELESS CHARGING COIL

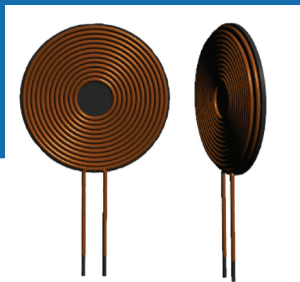

**AWCCA-RX350300-101**

Ø 35.00 x 3.0 mm

RoHS/RoHS II Compliant

MSL= 1

## FEATURES

- Wireless charging receiver coil
- Optimized for 19V/20W operation
- 25uH inductance
- 35mm diameter
- 3.0mm height
- High permeability shielding to protect sensitive electronics
- Durable construction
- Industrial -40°C to 85°C operating temperature
- Compatible with Semtech's high power 20W wireless charging receiver (TSDMRX-19V/20W-EVM)

## APPLICATIONS

- Industrial automation
- Medical devices
- Portable audio/video
- Robotics
- Drones
- Appliances
- Power tools

## MAXIMUM RATINGS

Item	Value
Operating Temperature Range	T = -25°C ~ 85°C, RH 65±20%
Storage Temperature Range	T = -40°C~85°C, RH 65±20%

## ELECTRICAL SPECIFICATIONS

Part Number	Inductance	DC Resistance	Q
AWCCA-RX350300-101	25µH±10%	170mΩ Max	85 Typ
Test Condition	100KHz / 1V	20±15°C	100KHz/1V
Test Equipment	HP4284A, HP42841A , Agilent 34420A or equivalent		
Test Environment	Temperature: 20±15°C, RH: 65% ±20%.		

**Test Conditions:** Ambient Temperature: 20±10°C, RH: 65% ±20%.

## PART IDENTIFICATION

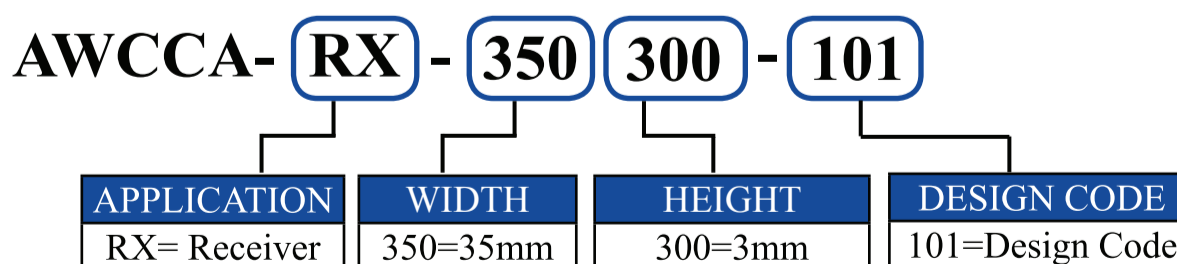

REVISED: 08/07/2018



5101 Hidden Creek Lane Spicewood TX 78669  
 Phone: 512-371-6159 | Fax: 512-351-8858  
 For terms and conditions of sale please visit:  
[www.abracon.com](http://www.abracon.com)

ABRACON IS  
 ISO9001-2015  
 CERTIFIED

# 20W RX DUAL MODE WIRELESS CHARGING COIL

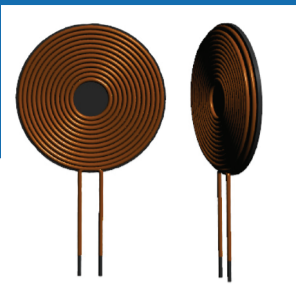

**AWCCA-RX350300-101**

Ø 35.00 x 3.0 mm

 **RoHS/RoHS II Compliant**  
MSL= 1

## MECHANICAL DIMENSIONS (ALL DIMENSIONS ARE IN mm)

Tolerances are ±0.2mm, unless otherwise specified\*

Dimensions of AWCCA-RX350300-101

Item	A	B	C	D	E	F	G	H
Spec	11.00	33.00	35.00	35.00	5.00	1.00	3.00	5.00
Tol	±0.5	±1.00	±0.80	±2.00	±2.00	±0.08	MAX	±1.50

Winding Details of AWCCA-RX350300-101

Number of Coils	Wire	Number of Turns	Inductance
1	USTC Wire Φ0.08 mm*50	13.5 Turns, 2 layer	25µH±10%
Magnetic Sheet		Format	
Soft Ferrite		1 layer / Φ35.0mm x 1.00mm	

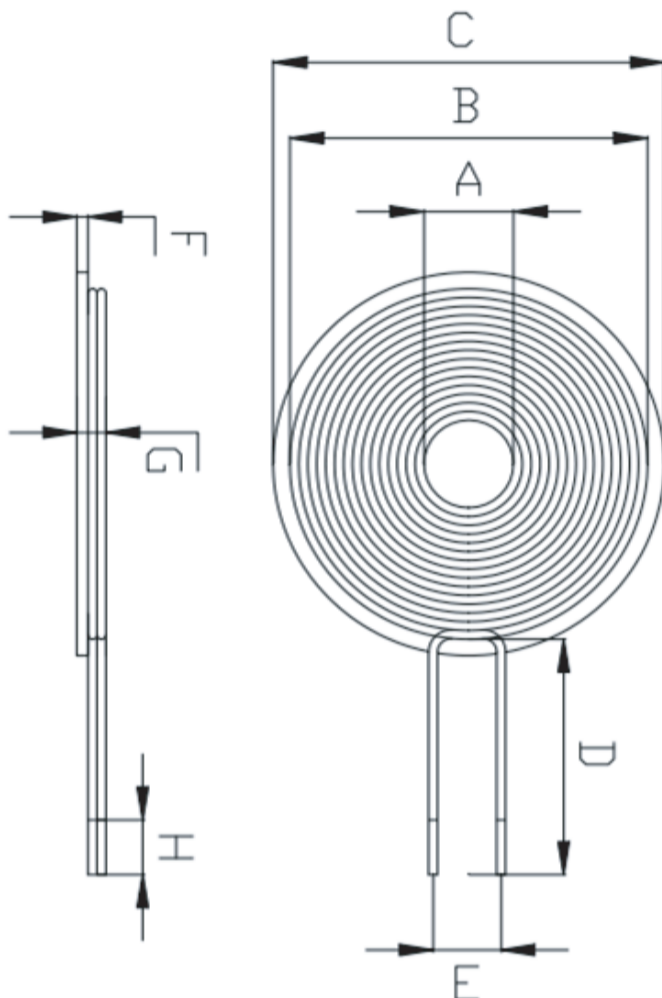

**Wave Soldering Profile:** Not suitable for wave soldering

**Manual Soldering:** 350°C Max, 3secs

**Packaging:** Tray packaging: 15 per grid, 300pcs per tray

Weight approximately: 2.8Kg

Tray dimensions 395 x 258 x 60mm

Carton packaging: 4 trays per carton, 1200pcs per carton

Weight approximately: 12Kg

Carton dimensions: 395 x 285 x 275mm

## STORAGE AND OPERATIONAL CONDITIONS

### Storage Conditions

1. Recommended storage conditions: -40°C~85°C, RH 65±20%
2. Service life: 12 Month @ 40°C, RH 40 ~ 65%
3. The appearance and solder ability should be check, if product is not in expiry date.

### Operation Conditions

1. Use condition limit: T= -25°C ~ 85°C, RH 65±20%

REVISED: 08/07/2018

# 20W RX DUAL MODE WIRELESS CHARGING COIL

**AWCCA-RX350300-101**

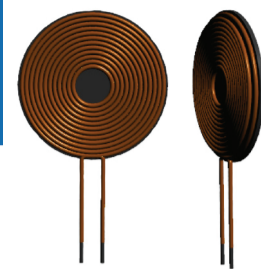

Ø 35.00 x 3.0 mm



RoHS/RoHS II Compliant

MSL= 1

## NOTES

---

1. The parts are manufactured in accordance with this specification. If other conditions and specifications which are required for this specification, please contact ABRACON for more information.
2. ABRACON will supply the parts in accordance with this specification unless we receive a written request to modify prior to an order placement.
3. In no case shall ABRACON be liable for any product failure from in appropriate handling or operation of the item beyond the scope of this specification.
4. When changing your production process, please notify ABRACON immediately.
5. ABRACON LLC's products are COTS – Commercial-Off-The-Shelf products; suitable for Commercial, Industrial and, where designated, Automotive Applications. ABRACON's products are not specifically designed for Military, Aviation, Aerospace, Life-dependant Medical applications or any application requiring high reliability where component failure could result in loss of life and/or property. For applications requiring high reliability and/or presenting an extreme operating environment, written consent and authorization from ABRACON LLC is required. Please contact ABRACON LLC for more information.
6. All specifications and Marking will be subject to change without notice.

REVISED: 08/07/2018



5101 Hidden Creek Lane Spicewood TX 78669  
Phone: 512-371-6159 | Fax: 512-351-8858  
For terms and conditions of sale please visit:  
[www.abracon.com](http://www.abracon.com)

ABRACON IS  
ISO9001-2015  
CERTIFIED

Компания «Life Electronics» занимается поставками электронных компонентов импортного и отечественного производства от производителей и со складов крупных дистрибьюторов Европы, Америки и Азии.

С конца 2013 года компания активно расширяет линейку поставок компонентов по направлению коаксиальный кабель, кварцевые генераторы и конденсаторы (керамические, пленочные, электролитические), за счёт заключения дистрибьюторских договоров

Мы предлагаем:

- Конкурентоспособные цены и скидки постоянным клиентам.
- Специальные условия для постоянных клиентов.
- Подбор аналогов.
- Поставку компонентов в любых объемах, удовлетворяющих вашим потребностям.
- Приемлемые сроки поставки, возможна ускоренная поставка.
- Доставку товара в любую точку России и стран СНГ.
- Комплексную поставку.
- Работу по проектам и поставку образцов.
- Формирование склада под заказчика.
- Сертификаты соответствия на поставляемую продукцию (по желанию клиента).
- Тестирование поставляемой продукции.
- Поставку компонентов, требующих военную и космическую приемку.
- Входной контроль качества.
- Наличие сертификата ISO.

В составе нашей компании организован Конструкторский отдел, призванный помогать разработчикам, и инженерам.

Конструкторский отдел помогает осуществить:

- Регистрацию проекта у производителя компонентов.
- Техническую поддержку проекта.
- Защиту от снятия компонента с производства.
- Оценку стоимости проекта по компонентам.
- Изготовление тестовой платы монтаж и пусконаладочные работы.



Тел: +7 (812) 336 43 04 (многоканальный)

Email: [org@lifeelectronics.ru](mailto:org@lifeelectronics.ru)