



SPnT Coaxial Switches DC to 6 GHz, DC to 20 GHz, DC to 26.5 GHz, DC to 40 GHz

Radiall's TITANIUM switches are optimised to perform at a high level over an extended life span. With outstanding RF performances, and a guaranteed Insertion Loss repeatability of 0.03 dB over a life span of 2,5 million switching cycles. RADIALL TITANIUM switches are perfect for automated test and measurement equipment, as well as signal monitoring devices.

PART NUMBER SELECTION

R 514 . 73 . . 7 .

NEW

RF Connectors :
3 : SMA up to 6 GHz
4 : SMA up to 20 GHz
F : SMA up to 26.5 GHz
8 : SMA 2.9 up to 40 GHz

Type :
7 : Latching + Self cut-off + Auto Reset + Indicators

Number of Positions :
4 : 4 positions
6 : 6 positions

Options :
1 : Positive common (without TTL)
2 : TTL/5V logic with 24 Vdc supply

Documentation :
- : Certificate Of Conformity
C : Calibration certificate
R : Calibration certificate + RF curves

Actuator Terminal :
7 : HE 10 receptacle, delivered with 750 mm (30 inches) ribbon cable + HE10 connector

PICTURE



**RF PERFORMANCES**

| PART NUMBER | R5143734-7 R5143736-7 | R5144734-7 R5144736-7 | R514F734-7 R514F736-7 | R5148734-7 R5148736-7 |
|----------------------------------|-----------------------------------|--|--|---|
| Frequency Range GHz | DC to 6 | DC to 20 | DC to 26.5 | DC to 40 |
| Impedance Ohms | 50 | | | |
| Insertion Loss dB (Maximum) | 0.3 + 0.015 x frequency (GHz) | | | |
| Isolation dB (Minimum) | 80 | DC to 6 GHz : 80 6 to 12.4 GHz : 70 12.4 to 20 GHz : 65 | DC to 6 GHz : 80 6 to 12.4 GHz : 70 12.4 to 20 GHz : 65 20 to 26.5 GHz : 60 | DC to 6 GHz : 80 6 to 12.4 GHz : 70 12.4 to 20 GHz : 65 20 to 26.5 GHz : 60 26.5 to 40 GHz : 55 |
| V.S.W.R. (Maximum) | 1.20 | DC to 6 GHz : 1.20 6 to 12.4 GHz : 1.35 12.4 to 18 GHz : 1.45 18 to 20 GHz : 1.70 | DC to 6 GHz : 1.20 6 to 12.4 GHz : 1.35 12.4 to 18 GHz : 1.45 18 to 26.5 GHz : 1.70 | DC to 6 GHz : 1.20 6 to 12.4 GHz : 1.35 12.4 to 18 GHz : 1.45 18 to 26.5 GHz : 1.70 26.5 to 40 GHz : 1.90 |
| Third order Inter Modulation | -120 dBc typical (2 carriers 20W) | | | |
| Repeatability (measured at 25°C) | 0.03 dB | | | 0.05 dB |

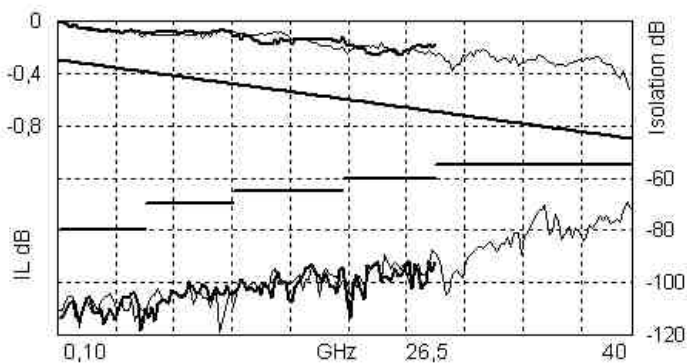
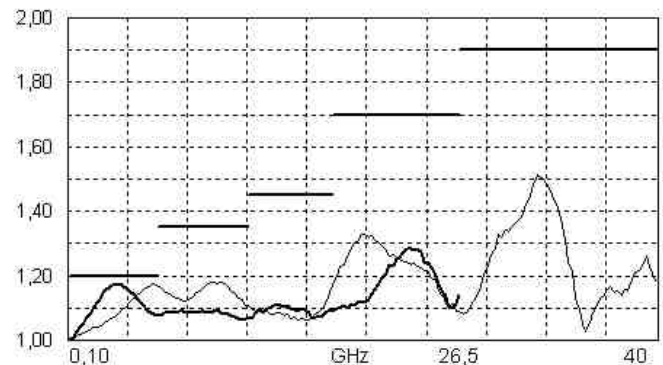
TYPICAL RF PERFORMANCES**Insertion Loss and Isolation****V.S.W.R.**

**ADDITIONAL SPECIFICATIONS**

| | | | |
|---|------------|---|-------------------------|
| Operating mode | | Latching | |
| Nominal operating voltage (across operating temperature) Vdc | | 24 (20 / 32) | |
| Coil resistance (+/-10%) | Ohms | 120 | |
| Nominal operating current at 23°C | | 200 | |
| Maximum stand-by current | | 50 | |
| Average power | | RF path Cold switching : see Power Rating Chart on page 8 Hot switching : 1 Watt CW | |
| | | Internal terminations 1 Watt average into 50 Ω | |
| TTL input | High Level | 3 to 7 V | 1.4 mA max at Vcc = Max |
| | Low Level | 0 to 0.8 V | |
| Indicator specifications | | Maximum withstanding voltage : 60V Maximum current capacity : 150 mA Maximum « ON » resistance : 2.5 Ω Minimum « OFF » resistance : 100 MΩ | |
| Switching time (max) | | 15 | |
| Life (min) for | SMA | 2,5 million cycles | |
| | SMA 2.9 | 1 million cycles | |
| Connectors | | SMA – SMA 2.9 | |
| Actuator terminal | | HE10 ribbon receptacle | |
| Weight (max) | | 230 | |

ENVIRONMENTAL SPECIFICATIONS

| | | |
|---|----|---------------------------------------|
| Operating temperature range | °C | -25 to +75 |
| Storage temperature range | °C | -55 to +85 |
| Temperature cycling (MIL-STD-202 , Method 107D , Cond.A) | °C | -55 to +85 (10 cycles) |
| Vibration (MIL STD 202 , Method 204D , Cond.D) | | 10-2000 Hz , 10g operating |
| Shock (MIL STD 202 , Method 213B , Cond.C) | | 50g / 6 ms , ½ sine operating |
| Moisture resistance (MIL STD 202 , Method 106E , Cond.E) | | 65°C, 95% RH, 10 days |
| Altitude storage (MIL STD 202 , Method 105C , Cond.B) | | 50,000 feet (15,240 meters) |
| RFI (MIL STD 1344 , Method 3008 or IEC 61726) | | 55dB at 20GHz |
| Magnetic field | | < 5.10 ⁻⁵ gauss at 1 meter |



ELECTRONIC POSITION INDICATORS

The electronic position indicators utilise photo-MOS transistors which are driven by the mechanical position of the RF paths moving elements. The circuitry consists of a common which can be connected to an output corresponding to selected RF path. If one or several RF paths are closed, the corresponding indicators are connected to the common. The photo-MOS transistors are configured for AC and/or DC operation. The electronic position indicators require the supply (20 to 32 VDC) to be connected to pin 1 and ground connected to pin 15.

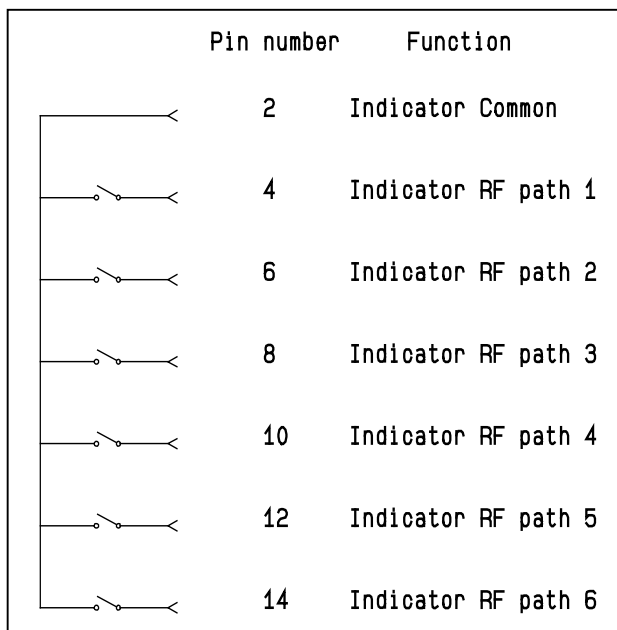

Ways 1 and 4 are not connected for SP4T switches.



DRIVING THE SWITCH : Type 7 : with TTL (option "2") / without TTL (option "1").

Each RF path can be closed by applying Ground or TTL "High" for option 2 to the corresponding "drive" pin. In general, except for Make-Before-Break drive, all other RF paths are simultaneously opened by internal logic.



Standard drive option "1"

- Connect pin 15 to ground.
- Connect pin 1 to supply (+20 VDC to +32 VDC)
- Select (close) desired RF path by applying Ground to the corresponding "drive" pin (Ex: apply Ground to pin 3 to close RF path 1).
- To select another path, ensure that all unwanted RF path "drive" pins are disconnected from Ground (to prevent multiple RF path engagement). Apply Ground to the "drive" pin which corresponds to the desired RF path.
- To open all RF paths, ensure that all RF path "drive" pins are disconnected from Ground. Complete the operation by applying Ground to pin 16.

TTL drive option "2"

- Connect pin 15 to ground.
- Connect pin 1 to supply (+20 VDC to +32 VDC)
- Select (close) desired RF path by applying TTL "High" to the corresponding "drive" pin (Ex: apply TTL "High" to pin 3 to close RF path 1).
- To select another path, ensure that all unwanted RF path "drive" pins are in TTL "Low" position (to prevent multiple RF path engagement). Apply TTL "High" to the "drive" pin which corresponds to the desired RF path.
- To open all RF paths, ensure that all RF path "drive" pins are in TTL "Low" position. Complete the operation by applying TTL "High" to pin 16.

Ways 1 and 4 are not connected for SP4T switches.

Break-Before-Make

Open the undesired RF path. After 15 ms (minimum), close the new RF port.

Make-Before-Break

Ensure that the previously selected RF path "drive" is connected to Ground (or TTL "High" for option "2", then close the new RF path.



TYPICAL OUTLINE DRAWING

SMA connectors

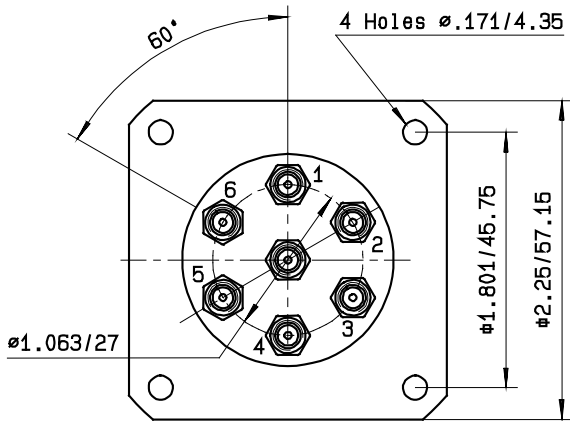

SMA 2.9 connectors

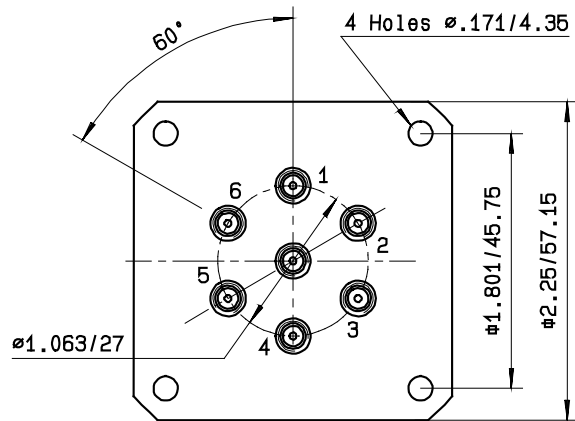

16 pin HB10 male connector

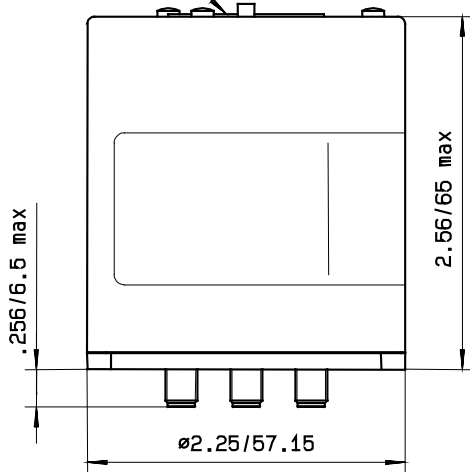

16 pin HB10 male connector

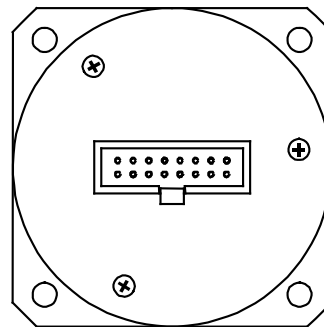
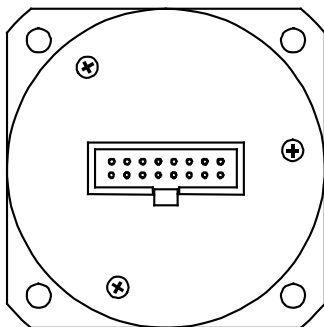
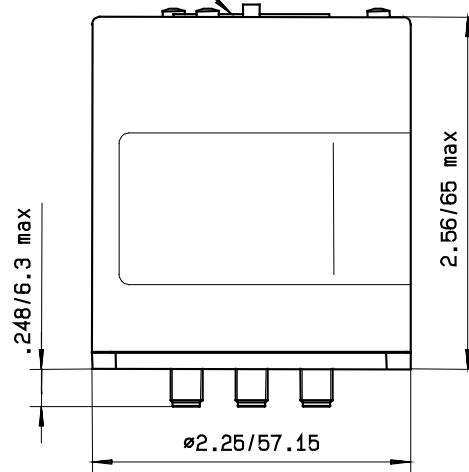

All dimensions are in inches/millimetres.

Ways 1 and 4 are not connected for SP4T





POWER RATING CHART

This graph is based on the following conditions :

- Ambient temperature : + 25°C
- Sea level
- V.S.W.R. : 1 and cold switching



DERATING FACTOR VERSUS V.S.W.R.

The average power input must be reduced for load V.S.W.R. above 1.



Компания «Life Electronics» занимается поставками электронных компонентов импортного и отечественного производства от производителей и со складов крупных дистрибьюторов Европы, Америки и Азии.

С конца 2013 года компания активно расширяет линейку поставок компонентов по направлению коаксиальный кабель, кварцевые генераторы и конденсаторы (керамические, пленочные, электролитические), за счёт заключения дистрибьюторских договоров

Мы предлагаем:

- Конкурентоспособные цены и скидки постоянным клиентам.
- Специальные условия для постоянных клиентов.
- Подбор аналогов.
- Поставку компонентов в любых объемах, удовлетворяющих вашим потребностям.
- Приемлемые сроки поставки, возможна ускоренная поставка.
- Доставку товара в любую точку России и стран СНГ.
- Комплексную поставку.
- Работу по проектам и поставку образцов.
- Формирование склада под заказчика.
- Сертификаты соответствия на поставляемую продукцию (по желанию клиента).
- Тестирование поставляемой продукции.
- Поставку компонентов, требующих военную и космическую приемку.
- Входной контроль качества.
- Наличие сертификата ISO.

В составе нашей компании организован Конструкторский отдел, призванный помогать разработчикам, и инженерам.

Конструкторский отдел помогает осуществить:

- Регистрацию проекта у производителя компонентов.
- Техническую поддержку проекта.
- Защиту от снятия компонента с производства.
- Оценку стоимости проекта по компонентам.
- Изготовление тестовой платы монтаж и пусконаладочные работы.



Тел: +7 (812) 336 43 04 (многоканальный)

Email: org@lifeelectronics.ru