

Description

ZXGD3009DY is a high-speed, non-inverting single gate driver for switching MOSFETs. It can transfer up to 1A peak source/sink current into the gate for effective charging and discharging of the capacitive load.

This gate driver ensures rapid switching of the MOSFET to minimize power losses and distortion in high current switching applications. It can typically drive 500mA into the low gate impedance with just 10mA input from a controller. The turn-on and turn-off switching behavior of the MOSFET can be individually tailored to suit an application. In particular, by defining the switching characteristics appropriately, EMI and cross conduction problems can be reduced.

Applications

Power MOSFET Gate Driving in:

- Power Supplies
- DC-DC Converters
- Amplifier Output Stages

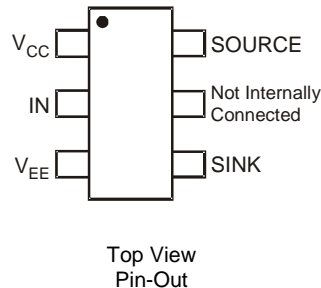
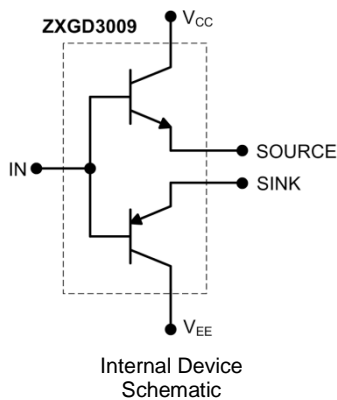

Pin Name	Pin Function
V _{CC}	Supply Voltage High
IN	Driver Input
V _{EE}	Supply Voltage Low
SOURCE	Source Current Output
SINK	Sink Current Output

Features

- High-Gain Buffer with Typically 500mA Output from 10mA Input
- Emitter-Follower that is Rugged to Latch-Up/Shoot-Through Issues
- Wide Supply Voltage to Minimize On-Losses
- Separate Source and Sink Outputs for Independent Control of MOSFET Turn-On and Turn-Off Times
- Optimized Pin-Out to Simplify PCB Layout and Reduce Parasitic Trace Inductances
- Near-Zero Quiescent Supply Current
- **Totally Lead-Free & Fully RoHS Compliant (Notes 1 & 2)**
- **Halogen and Antimony Free. "Green" Device (Note 3)**

Mechanical Data

- Case: SOT363
- Case material: Molded Plastic, "Green" Molding Compound. UL Flammability Rating 94V-0
- Moisture Sensitivity: Level 1 per J-STD-020
- Terminals: Finish - Matte Tin Plated Leads. Solderable per MIL-STD-202, Method 208[Ⓔ]
- Weight: 0.018 grams (Approximate)

Ordering Information (Note 4)

Product	Marking	Reel size (inches)	Tape width (mm)	Quantity per reel
ZXGD3009DYTA	3009	7	8	3,000

- Notes:
1. No purposely added lead. Fully EU Directive 2002/95/EC (RoHS) & 2011/65/EU (RoHS 2) compliant.
 2. See http://www.diodes.com/quality/lead_free.html for more information about Diodes Incorporated's definitions of Halogen- and Antimony-free, "Green" and Lead-free.
 3. Halogen- and Antimony-free "Green" products are defined as those which contain <900ppm bromine, <900ppm chlorine (<1500ppm total Br + Cl) and <1000ppm antimony compounds.
 4. For packaging details, go to our website at <http://www.diodes.com/products/packages.html>.

Marking Information

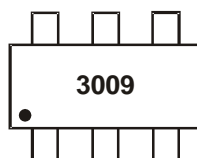

3009 = Product Type Marking Code

Absolute Maximum Ratings (@T_A = +25°C, unless otherwise specified.)

Characteristic	Symbol	Value	Unit
Supply Voltage, with Respect to V _{EE}	V _{CC}	40	V
Input Voltage, with Respect to V _{EE}	V _{IN}	40	V
Output Difference Voltage (Source – Sink)	ΔV _(source-sink)	±7	V
Peak Pulsed Output Current (Source and Sink)	I _{OM}	±2	A
Peak Pulsed Input Current	I _{IM}	±1	A

Thermal Characteristics (@T_A = +25°C, unless otherwise specified.)

Characteristic	Symbol	Value	Unit
Power Dissipation	P _D	320	mW
		277	
Thermal Resistance, Junction to Ambient	R _{θJA}	391	°C/W
		450	
Thermal Resistance, Junction to Lead (Note 8)	R _{θJL}	350	
Operating and Storage Temperature Range	T _J , T _{STG}	-55 to +150	°C

ESD Ratings (Note 9)

Characteristics	Symbols	Value	Unit	JEDEC Class
Electrostatic Discharge – Human Body Model	ESD HBM	4,000	V	3A
Electrostatic Discharge – Machine Model	ESD MM	400	V	C

- Notes:
5. For a device mounted with pin 1 (V_{CC}) and pin 3 (V_{EE}) on 25mm x 25mm 1oz copper that is on a single-sided 1.6mm FR4 PCB; device is measured under still air conditions whilst operating in steady-state. The heatsink is split in half with pin 1 (V_{CC}) and pin 3 (V_{EE}) connected separately to each half.
 6. Same as Note 5, except the device is mounted on minimum recommended pad layout.
 7. For device with two active die running at equal power.
 8. Thermal resistance from junction to solder-point at the end of each lead on pin 1 (V_{CC}) and pin 3 (V_{EE}).
 9. Refer to JEDEC specification JESD22-A114 and JESD22-A115.

Electrical Characteristics (@T_A = +25°C, unless otherwise specified.)

Characteristic	Symbol	Min	Typ	Max	Unit	Test Condition
Output Voltage, High	V _{OH}	V _{CC} - 0.8	V _{CC} - 0.4	—	V	I _(source) = 1μA, V _{IN} = V _{CC}
Output Voltage, Low	V _{OL}	-	V _{EE} + 0.2	V _{EE} + 0.5		I _(sink) = 1μA, V _{IN} = V _{EE}
Supply Breakdown Voltage	BV _{CC}	40	—	—	V	I _Q = 100μA, V _{IN} = V _{CC}
		40	—	—		I _Q = 100μA, V _{IN} = V _{EE} = 0V
Quiescent Supply Current	I _Q	—	—	20	nA	V _{CC} = 32V, V _{IN} = V _{CC}
		—	—	20		V _{CC} = 32V, V _{IN} = V _{EE} = 0V
Peak Pulsed Source Current	I _{(source)M}	—	0.98	—	A	I _{IN} = 10mA, V _{CC} = 5V, V _{OUT} = 0V
Peak Pulsed Sink Current	I _{(sink)M}	—	0.78	—		I _{IN} = -10mA, V _{EE} = 0V, V _{OUT} = 5V
Peak Pulsed Source Current	I _{(source)M}	—	1.58	—	A	I _{IN} = 50mA, V _{CC} = 5V, V _{OUT} = 0V
Peak Pulsed Sink Current	I _{(sink)M}	—	1.38	—		I _{IN} = -50mA, V _{EE} = 0V, V _{OUT} = 5V
Peak Pulsed Source Current with Varying Input Resistances	I _{(source)M}	—	0.74 0.175 0.019	—	A	R _{IN} = 100Ω R _{IN} = 1kΩ R _{IN} = 10kΩ V _{CC} = 15V, V _{EE} = 0V V _{IN} = 15V C _L = 1nF, R _L = 0.18Ω R _{SOURCE} = 0Ω, R _{SINK} = 0Ω
Peak Pulsed Sink Current with Varying Input Resistances	I _{(sink)M}	—	1.05 0.22 0.025	—	A	R _{IN} = 100Ω R _{IN} = 1kΩ R _{IN} = 10kΩ V _{CC} = 15V, V _{EE} = 0V V _{IN} = 15V C _L = 1nF, R _L = 0.18Ω R _{SOURCE} = 0Ω, R _{SINK} = 0Ω
Switching Times with Low Input Resistance	t _{d(rise)} t _r t _{d(fall)} t _f	—	3.8 15 4 15	—	ns	V _{CC} = 12V, V _{EE} = 0V V _{IN} = 0 to 10V R _{IN} = 25Ω C _L = 1nF, R _L = 0.18Ω R _{SOURCE} = 0Ω, R _{SINK} = 0Ω
Switching Times with Low Load Capacitance C _L = 1nF	t _{d(rise)} t _r t _{d(fall)} t _f	—	18 36 16 40	—	ns	V _{CC} = 15V, V _{EE} = 0V V _{IN} = 0 to 15V R _{IN} = 1kΩ C _L = 1nF, R _L = 0.18Ω R _{SOURCE} = 0Ω, R _{SINK} = 0Ω
Switching Times with High Load Capacitance C _L = 10nF	t _{d(rise)} t _r t _{d(fall)} t _f	—	47 210 39 240	—	ns	V _{CC} = 15V, V _{EE} = 0V V _{IN} = 0 to 15V R _{IN} = 1kΩ C _L = 10nF, R _L = 0.18Ω R _{SOURCE} = 0Ω, R _{SINK} = 0Ω

Switching Test Circuit and Timing Diagram

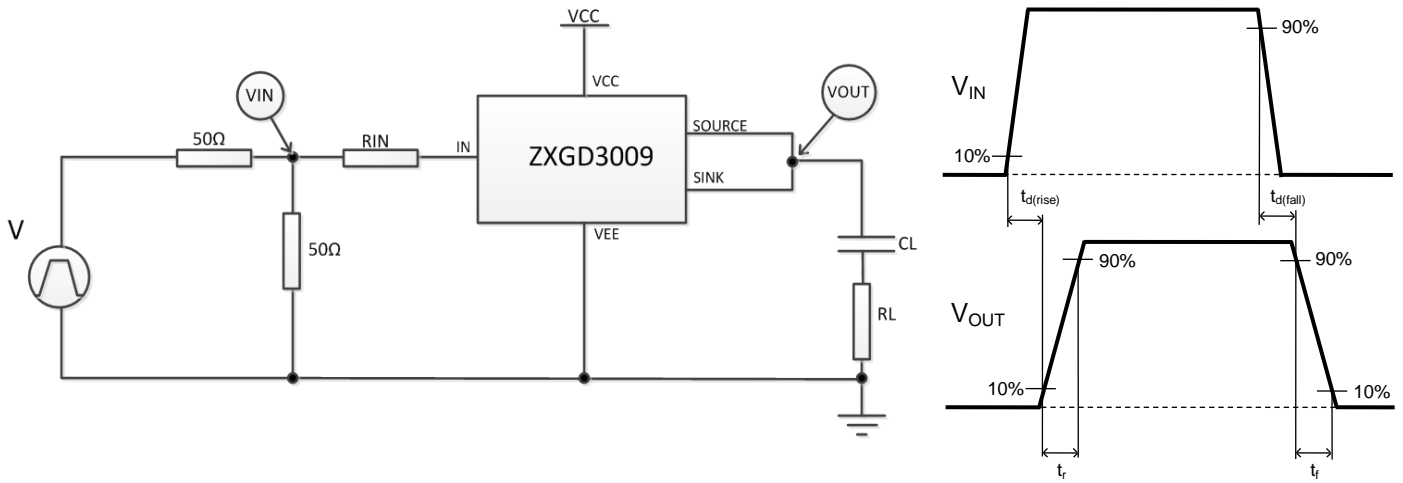

Typical Application Circuit

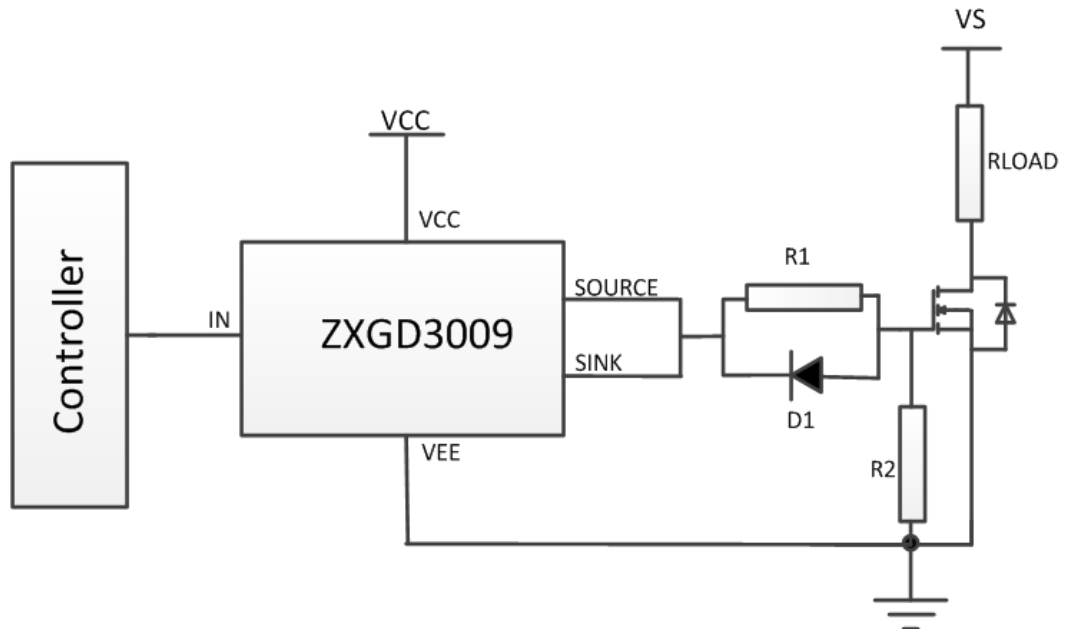

R1, D1 combination can be used for variable turn on and turn off times.

Typical Switching Characteristics (@ $T_A = +25^\circ\text{C}$, unless otherwise specified.)

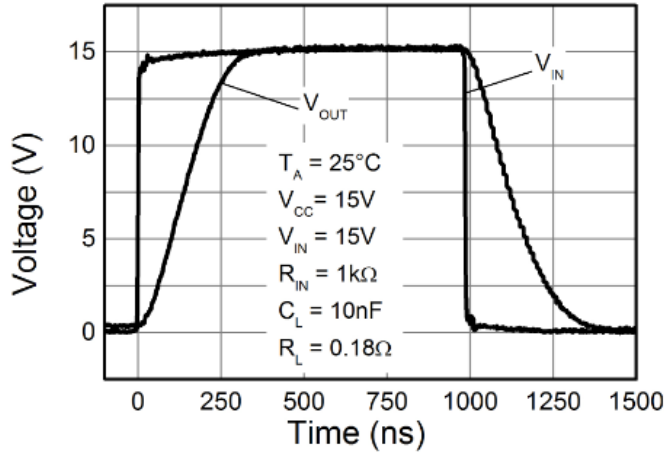

Switching Speed

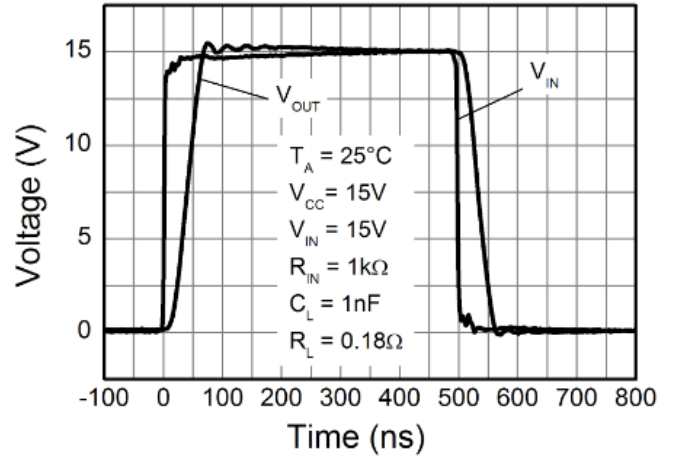

Switching Speed

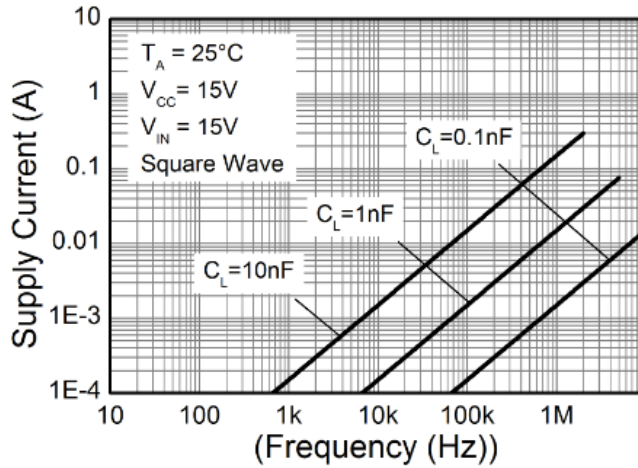

Supply Current

Typical Switching Characteristics (@ $T_A = +25^\circ\text{C}$, unless otherwise specified.)

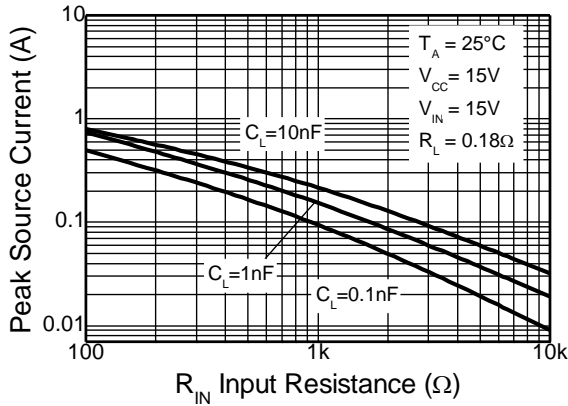

Source Current vs. Input Resistance

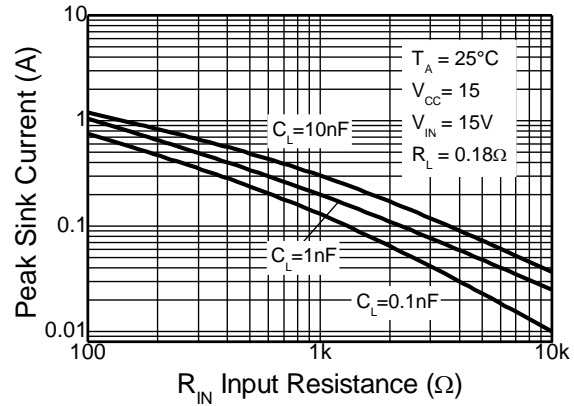

Sink Current vs. Input Resistance

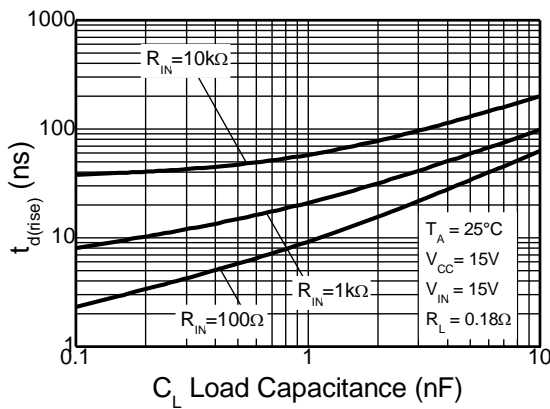

Turn-On Delay Time

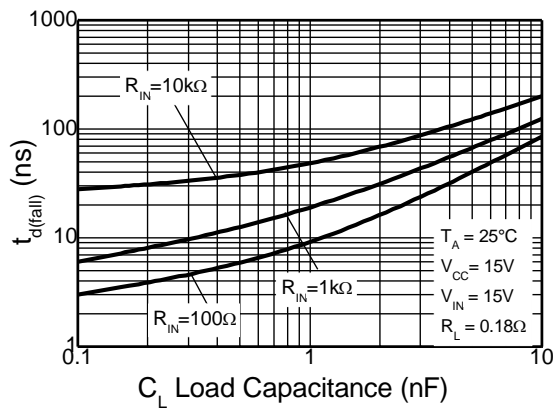

Turn-Off Delay Time

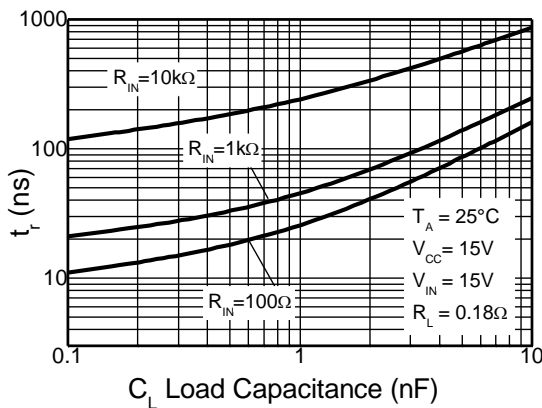

Turn-On Rise Time

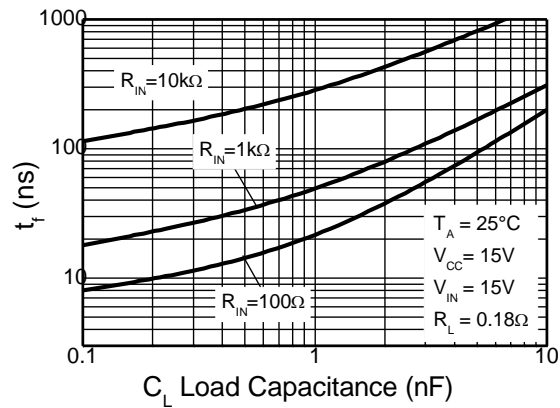

Turn-Off Fall Time

Package Outline Dimensions

Please see AP02002 at <http://www.diodes.com/datasheets/ap02002.pdf> for the latest version.

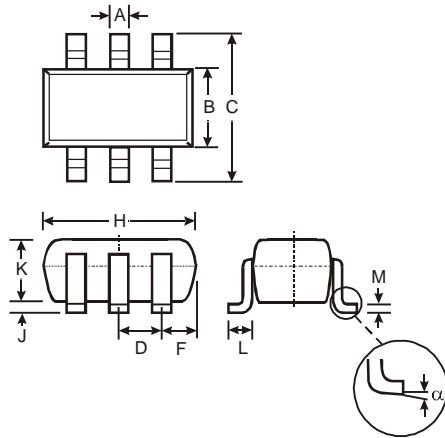

SOT363			
Dim	Min	Max	Typ
A	0.10	0.30	0.25
B	1.15	1.35	1.30
C	2.00	2.20	2.10
D	0.65 Typ		
F	0.40	0.45	0.425
H	1.80	2.20	2.15
J	0	0.10	0.05
K	0.90	1.00	1.00
L	0.25	0.40	0.30
M	0.10	0.22	0.11
α	0°	8°	-
All Dimensions in mm			

Suggested Pad Layout

Please see AP02001 at <http://www.diodes.com/datasheets/ap02001.pdf> for the latest version.

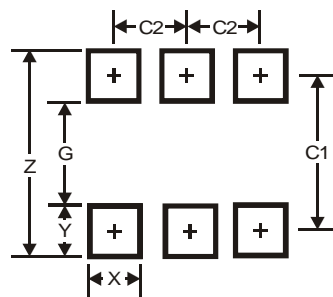

Dimensions	Value (in mm)
Z	2.5
G	1.3
X	0.42
Y	0.6
C1	1.9
C2	0.65

IMPORTANT NOTICE

DIODES INCORPORATED MAKES NO WARRANTY OF ANY KIND, EXPRESS OR IMPLIED, WITH REGARDS TO THIS DOCUMENT, INCLUDING, BUT NOT LIMITED TO, THE IMPLIED WARRANTIES OF MERCHANTABILITY AND FITNESS FOR A PARTICULAR PURPOSE (AND THEIR EQUIVALENTS UNDER THE LAWS OF ANY JURISDICTION).

Diodes Incorporated and its subsidiaries reserve the right to make modifications, enhancements, improvements, corrections or other changes without further notice to this document and any product described herein. Diodes Incorporated does not assume any liability arising out of the application or use of this document or any product described herein; neither does Diodes Incorporated convey any license under its patent or trademark rights, nor the rights of others. Any Customer or user of this document or products described herein in such applications shall assume all risks of such use and will agree to hold Diodes Incorporated and all the companies whose products are represented on Diodes Incorporated website, harmless against all damages.

Diodes Incorporated does not warrant or accept any liability whatsoever in respect of any products purchased through unauthorized sales channel. Should Customers purchase or use Diodes Incorporated products for any unintended or unauthorized application, Customers shall indemnify and hold Diodes Incorporated and its representatives harmless against all claims, damages, expenses, and attorney fees arising out of, directly or indirectly, any claim of personal injury or death associated with such unintended or unauthorized application.

Products described herein may be covered by one or more United States, international or foreign patents pending. Product names and markings noted herein may also be covered by one or more United States, international or foreign trademarks.

This document is written in English but may be translated into multiple languages for reference. Only the English version of this document is the final and determinative format released by Diodes Incorporated.

LIFE SUPPORT

Diodes Incorporated products are specifically not authorized for use as critical components in life support devices or systems without the express written approval of the Chief Executive Officer of Diodes Incorporated. As used herein:

A. Life support devices or systems are devices or systems which:

1. are intended to implant into the body, or
2. support or sustain life and whose failure to perform when properly used in accordance with instructions for use provided in the labeling can be reasonably expected to result in significant injury to the user.

B. A critical component is any component in a life support device or system whose failure to perform can be reasonably expected to cause the failure of the life support device or to affect its safety or effectiveness.

Customers represent that they have all necessary expertise in the safety and regulatory ramifications of their life support devices or systems, and acknowledge and agree that they are solely responsible for all legal, regulatory and safety-related requirements concerning their products and any use of Diodes Incorporated products in such safety-critical, life support devices or systems, notwithstanding any devices- or systems-related information or support that may be provided by Diodes Incorporated. Further, Customers must fully indemnify Diodes Incorporated and its representatives against any damages arising out of the use of Diodes Incorporated products in such safety-critical, life support devices or systems.

Copyright © 2014, Diodes Incorporated

www.diodes.com

Компания «Life Electronics» занимается поставками электронных компонентов импортного и отечественного производства от производителей и со складов крупных дистрибьюторов Европы, Америки и Азии.

С конца 2013 года компания активно расширяет линейку поставок компонентов по направлению коаксиальный кабель, кварцевые генераторы и конденсаторы (керамические, пленочные, электролитические), за счёт заключения дистрибьюторских договоров

Мы предлагаем:

- Конкуренспособные цены и скидки постоянным клиентам.
- Специальные условия для постоянных клиентов.
- Подбор аналогов.
- Поставку компонентов в любых объемах, удовлетворяющих вашим потребностям.
- Приемлемые сроки поставки, возможна ускоренная поставка.
- Доставку товара в любую точку России и стран СНГ.
- Комплексную поставку.
- Работу по проектам и поставку образцов.
- Формирование склада под заказчика.
- Сертификаты соответствия на поставляемую продукцию (по желанию клиента).
- Тестирование поставляемой продукции.
- Поставку компонентов, требующих военную и космическую приемку.
- Входной контроль качества.
- Наличие сертификата ISO.

В составе нашей компании организован Конструкторский отдел, призванный помогать разработчикам, и инженерам.

Конструкторский отдел помогает осуществить:

- Регистрацию проекта у производителя компонентов.
- Техническую поддержку проекта.
- Защиту от снятия компонента с производства.
- Оценку стоимости проекта по компонентам.
- Изготовление тестовой платы монтаж и пусконаладочные работы.



Тел: +7 (812) 336 43 04 (многоканальный)

Email: org@lifeelectronics.ru