

Amplified SiSonic™ Microphone

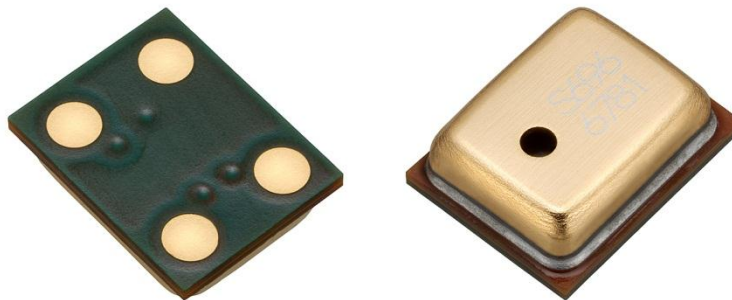

The SPU0414HR5H-SB is a miniature, high-performance, low power, top port silicon microphone. Using Knowles' proven high performance SiSonic™ MEMS technology, the SPU0414HR5H-SB consists of an acoustic sensor, a low noise input buffer, and an output amplifier. These devices are suitable for applications such as cellphones, smart phones, laptop computers, sensors, digital still cameras, portable music recorders, and other portable electronic devices where excellent wideband audio performance and RF immunity are required.

Features:

- Up to 20dB of Gain
- Low Current
- Small package
- MaxRF protection
- Ultra-Stable Performance
- Standard SMD Reflow
- Omnidirectional

1. ABSOLUTE MAXIMUM RATINGS

| Parameter | Absolute Maximum Rating | Units |
|---------------------------|-----------------------------|-------|
| V _{DD} to Ground | -0.5, +5.0 | V |
| OUT to Ground | -0.3, V _{DD} + 0.3 | V |
| Input Current to Any Pin | ±5 | mA |
| Temperature Range | -40 to +100 | °C |

Stresses exceeding these “Absolute Maximum Ratings” may cause permanent damage to the device. These are stress ratings only. Functional operation at these or any other conditions beyond those indicated under “Acoustic & Electrical Specifications” is not implied. Exposure beyond those indicated under “Acoustic & Electrical Specifications” for extended periods may affect device reliability.

2. ACOUSTIC & ELECTRICAL SPECIFICATIONS

TEST CONDITIONS: 23 ±2°C, 60-70% R.H., V_{DD}(min) < V_{DD} < V_{DD}(max), no load, unless otherwise indicated

| Parameter | Symbol | Conditions | Min | Typ | Max | Units |
|-------------------------------|------------------|---|---------------------------|------|-----|--------|
| Supply Voltage ¹ | V _{DD} | | 1.5 | - | 3.6 | V |
| Supply Current ^{1,2} | I _{DD} | | - | 155 | 220 | μA |
| Sensitivity ¹ | S | 94 dB SPL @ 1 kHz | -25 | -22 | -19 | dBV/Pa |
| Signal to Noise Ratio | SNR | 94 dB SPL @ 1 kHz, A-weighted | - | 59 | - | dB(A) |
| Total Harmonic Distortion | THD | 94 dB SPL @ 1 kHz, S = Typ, R _{load} > 2 kΩ | - | - | 1 | % |
| Acoustic Overload Point | AOP | 10% THD @ 1 kHz, S = Typ, V _{DD} = 3.6V, R _{load} > 2 kΩ | 115 ³ | - | - | dB SPL |
| DC Output | | V _{DD} = 1.5V | - | 0.93 | - | V |
| Output Impedance | Z _{OUT} | @ 1 kHz | - | - | 400 | Ω |
| Directivity | | | Omnidirectional | | | |
| Polarity | | Increasing sound pressure | Decreasing output voltage | | | |

¹ 100% tested.

² Maximum specifications are measured at maximum V_{DD}. Typical specifications are measured at V_{DD} = 1.8V.

³ For gain = 20dB, AOP(min) = 95 dB SPL.

3. FREQUENCY RESPONSE CURVE

**Typical Free Field Response
Normalized to 1 kHz (C1 = 2.2 μ F)**

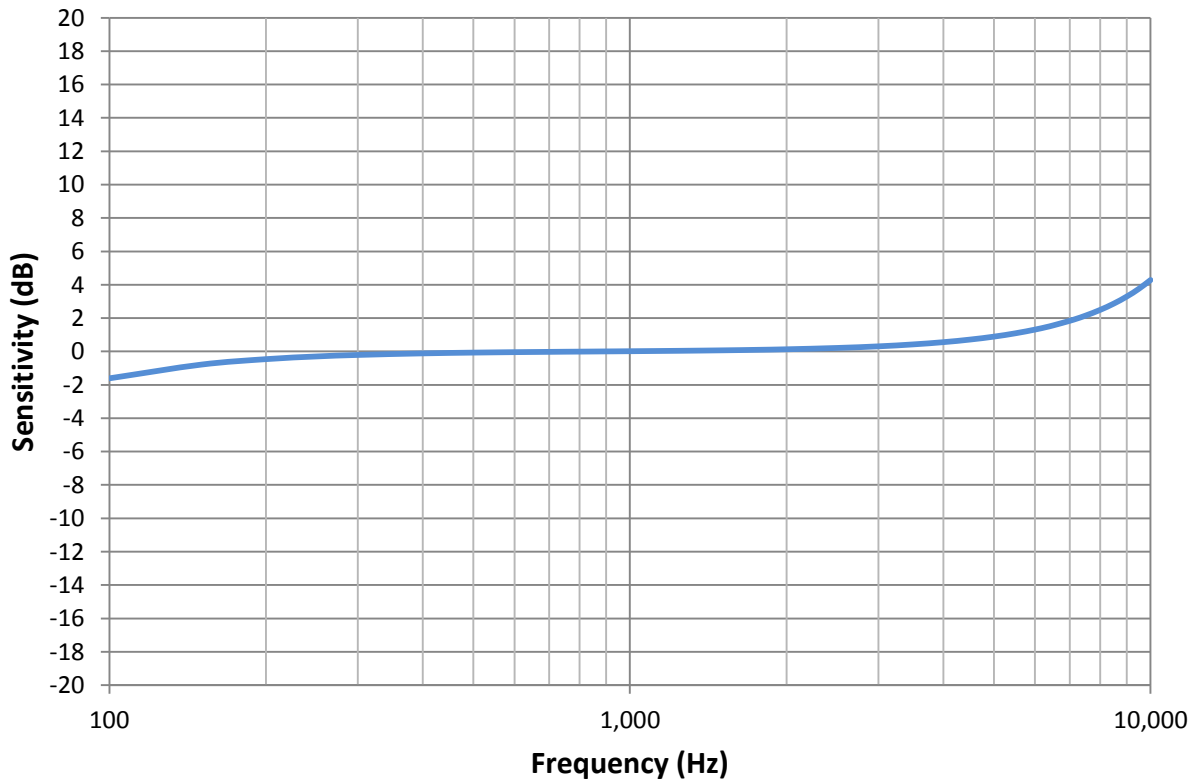

4. INTERFACE CIRCUIT

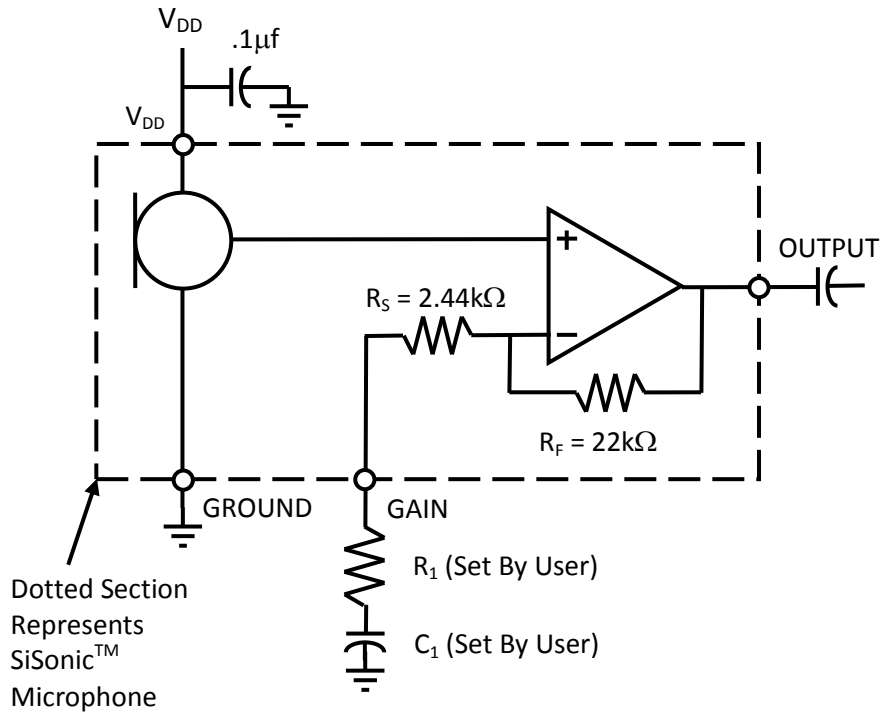

| Gain | GAIN Pin Termination |
|-------------------------------|--|
| Unity Gain (0dB) | Connect GAIN to OUTPUT |
| Max Gain (20dB) | Set $R_1 = 0\Omega$. Set C_1 according to equation below: Highpass corner frequency = $\frac{1}{2\pi R_S C_1}$ |
| Adjustable Gain (0dB to 20dB) | Set R_1 and C_1 according to the equations below: Gain(dB) = $20\log\left(1 + \frac{R_F}{R_S + R_1}\right)$ Highpass corner frequency = $\frac{1}{2\pi(R_S + R_1)C_1}$ |

Note: Capacitors near the microphone should not contain Class 2 dielectrics.

Detailed information on acoustic, mechanical, and system integration can be found in the latest *SiSonic™ Design Guide* application note.

5. MECHANICAL SPECIFICATIONS

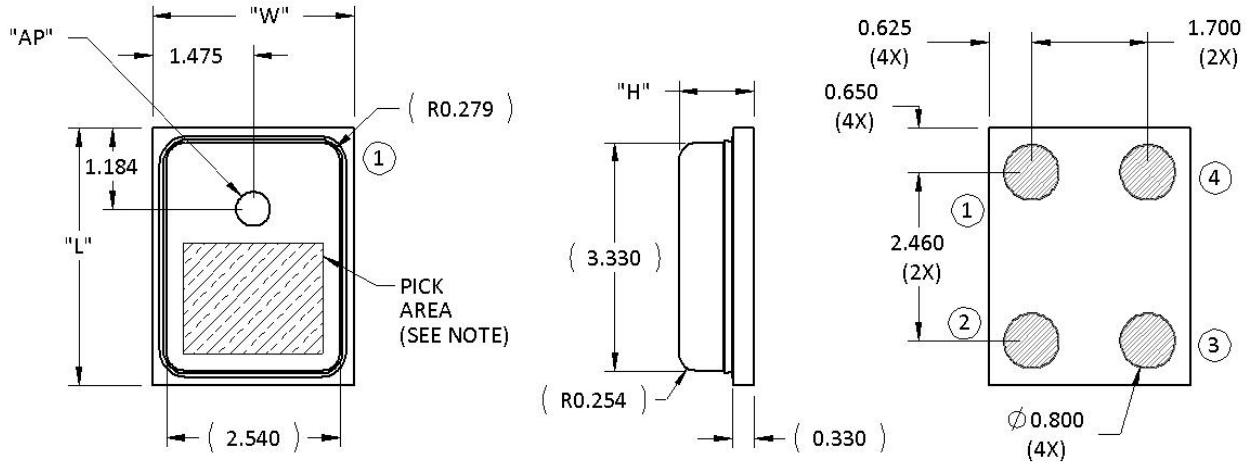

| Item | Dimension | Tolerance |
|--------------------|-----------|-----------|
| Length (L) | 3.76 | ±0.10 |
| Width (W) | 2.95 | ±0.10 |
| Height (H) | 1.10 | ±0.10 |
| Acoustic Port (AP) | Ø0.50 | ±0.05 |

| Pin # | Pin Name | Type | Description |
|-------|-----------------|--------|------------------------------|
| 1 | V _{DD} | Power | Power Supply |
| 2 | GROUND | Power | Ground |
| 3 | GAIN | Signal | Connect resistor to set gain |
| 4 | OUTPUT | Signal | Output Signal |

Notes: Pick Area only extends to 0.25 mm of any edge or hole unless otherwise specified.

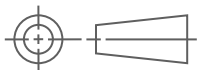

Dimensions are in millimeters unless otherwise specified.

Tolerance is ±0.15mm unless otherwise specified

6. EXAMPLE LAND PATTERN

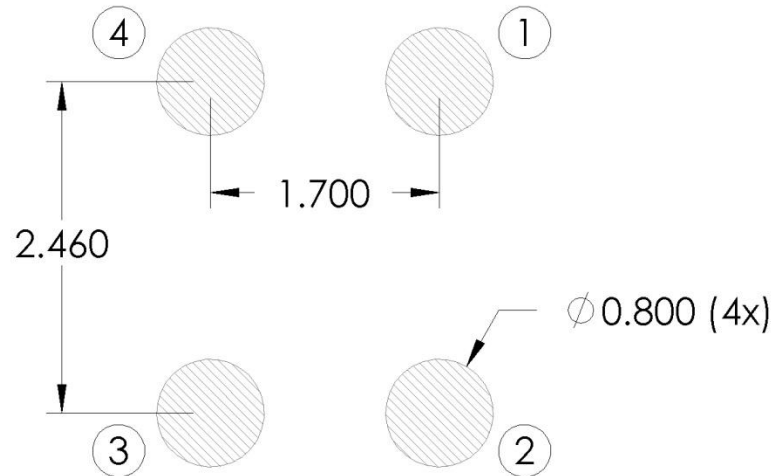

7. EXAMPLE SOLDER STENCIL PATTERN

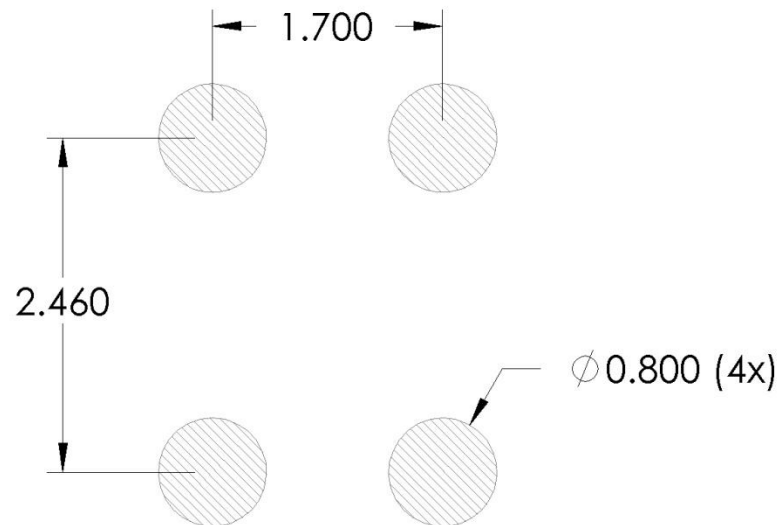

Notes: Dimensions are in millimeters unless otherwise specified.

Further optimizations based on application should be performed.

8. PACKAGING & MARKING DETAIL

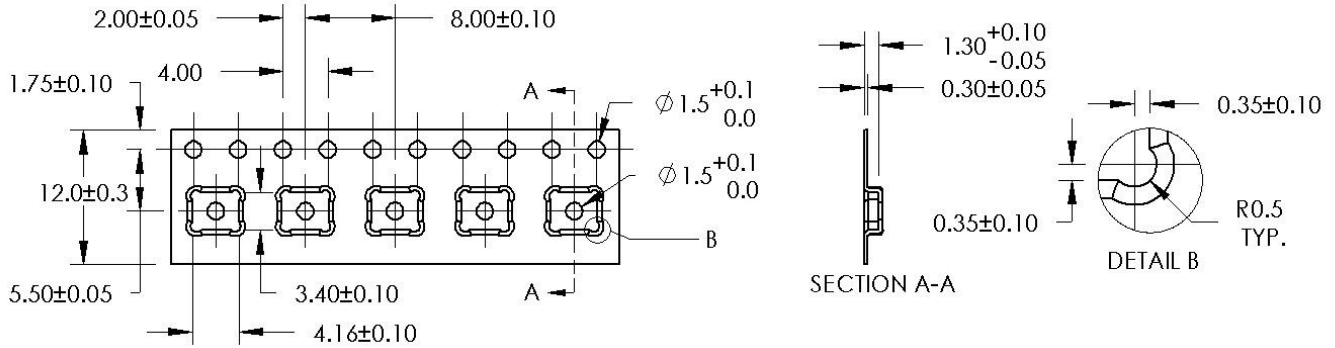

| Model Number | Suffix | Reel Diameter | Quantity Per Reel |
|----------------|--------|---------------|-------------------|
| SPU0414HR5H-SB | -7 | 13" | 5,700 |

Alpha Character A:

“S”: Knowles SiSonic™ Production

“E”: Knowles Engineering Samples

“P”: Knowles Prototype Samples

“JIN NUMBER”:

Unique Job Identification Number for product traceability

Pin 1

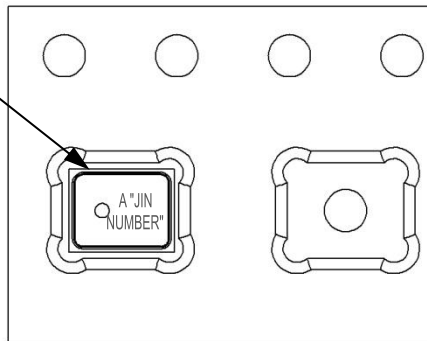

Notes: Dimensions are in millimeters unless otherwise specified.

Vacuum pickup only in the pick area indicated in Mechanical Specifications.

Tape & reel per EIA-481.

Labels applied directly to reel and external package.

9. RECOMMENDED REFLOW PROFILE

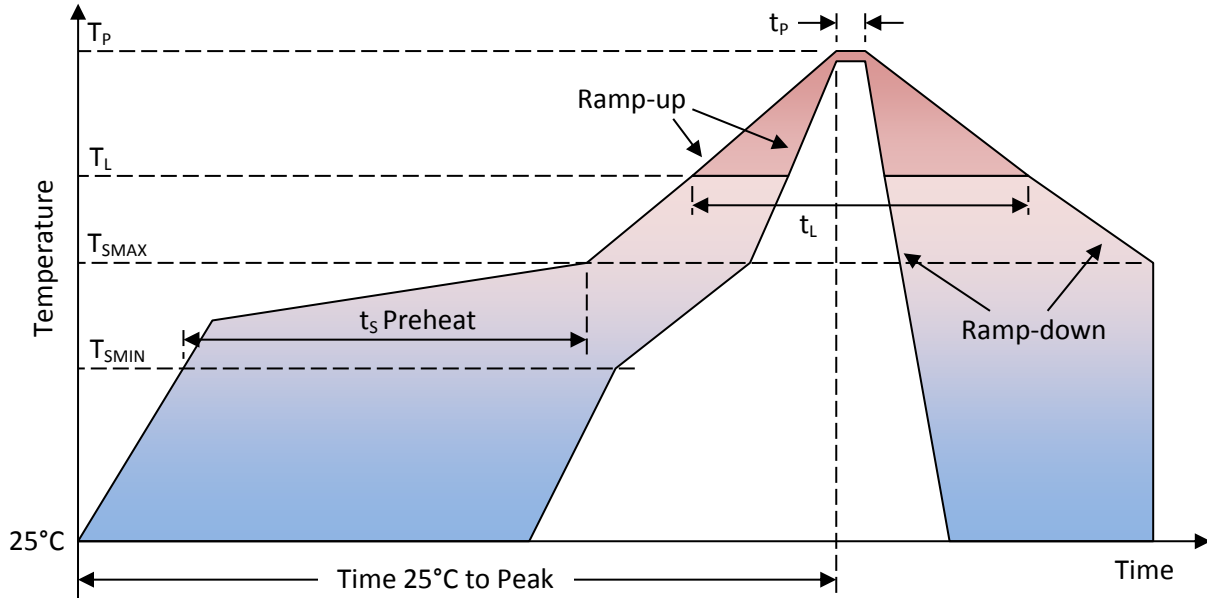

| Profile Feature | Pb-Free |
|--|----------------------------------|
| Average Ramp-up rate ($T_{S\text{MAX}}$ to T_P) | 3°C/second max. |
| Preheat <ul style="list-style-type: none"> • Temperature Min ($T_{S\text{MIN}}$) • Temperature Max ($T_{S\text{MAX}}$) • Time ($T_{S\text{MIN}}$ to $T_{S\text{MAX}}$) (t_s) | 150°C 200°C 60-180 seconds |
| Time maintained above: <ul style="list-style-type: none"> • Temperature (T_L) • Time (t_L) | 217°C 60-150 seconds |
| Peak Temperature (T_P) | 260°C |
| Time within 5°C of actual Peak Temperature (t_p) | 20-40 seconds |
| Ramp-down rate (T_P to $T_{S\text{MAX}}$) | 6°C/second max |
| Time 25°C to Peak Temperature | 8 minutes max |

Notes: Based on IPC/JDEC J-STD-020 Revision C.

All temperatures refer to topside of the package, measured on the package body surface.



10. ADDITIONAL NOTES

(A) Shelf life: Twelve (12) months when devices are to be stored in factory supplied, unopened ESD moisture sensitive bag under maximum environmental conditions of 30°C, 70% R.H.

(B) MSL (moisture sensitivity level) Class 1.

(C) Maximum of 3 reflow cycles is recommended.

(D) In order to minimize device damage:

- Do not board wash or clean after the reflow process.
- Do not brush board with or without solvents after the reflow process.
- Do not directly expose to ultrasonic processing, welding, or cleaning.
- Do not insert any object in port hole of device at any time.
- Do not apply over 30 psi of air pressure into the port hole.
- Do not pull a vacuum over port hole of the microphone.
- Do not apply a vacuum when repacking into sealed bags at a rate faster than 0.5 atm/sec.

11. MATERIALS STATEMENT

Meets the requirements of the European RoHS directive 2002/95/EC as amended.

Meets the requirements of the industry standard IEC 61249-2-21:2003 for halogenated substances and Knowles Green Materials Standards Policy section on Halogen-Free.

Ozone depleting substances are not used in the product or the processes used to make the product, including compounds listed in Annex A, B, and C of the “Montreal Protocol on Substances That Deplete the Ozone Layer.”

12. RELIABILITY SPECIFICATIONS

| Test | Description |
|-----------------------------|--|
| Thermal Shock | 100 cycles air-to-air thermal shock from -40°C to +125°C with 15 minute soaks. (IEC 68-2-4) |
| High Temperature Storage | 1,000 hours at +105°C environment (IEC 68-2-2 Test Ba) |
| Low Temperature Storage | 1,000 hours at -40°C environment (IEC 68-2-2 Test Aa) |
| High Temperature Bias | 1,000 hours at +105°C under bias (IEC 68-2-2 Test Ba) |
| Low Temperature Bias | 1,000 hours at -40°C under bias (IEC 68-2-2 Test Aa) |
| Temperature / Humidity Bias | 1,000 hours at +85°C/85% R.H. under bias. (JESD22-A101A-B) |
| Vibration | 4 cycles of 20 to 2,000 Hz sinusoidal sweep with 20 G peak acceleration lasting 12 minutes in X, Y, and Z directions. (Mil-Std-883E, method 2007.2 A) |
| Electrostatic Discharge | 3 discharges of ±8 kV direct contact to lid while unit is grounded (IEC 61000-4-2) and 3 discharges of ±2 kV direct contact to I/O pins. (MIL 883E, Method 3015.7) |
| Reflow | 5 reflow cycles with peak temperature of +260°C |
| Mechanical Shock | 3 pulses of 10,000 G in the X, Y, and Z direction (IEC 68-2-27, Test Ea) |

Note: After reliability tests are performed, the sensitivity of the microphones shall not deviate more than 3 dB from its initial value.



SPU0414HR5H-SB

13. SPECIFICATION REVISIONS

| Revision | Specification Changes | Date |
|----------|--|----------|
| A | Initial Release (C10109400) | 4/23/09 |
| C | Update Sections 2, 3, 4, 6, 8; misc cleanup (C10112517) | 10/21/10 |
| D | Update Section 2, 3, 7, 8, 10, 11; misc cleanup (C10113579) | 11/10/11 |
| E | Released in new format; add DC Output; new JIN designation (C10114423) | 12/04/12 |
| | | |
| | | |
| | | |
| | | |
| | | |
| | | |
| | | |

Information contained herein is subject to change without notice. It may be used by a party at their own discretion and risk. We do not guarantee any results or assume any liability in connection with its use. This publication is not to be taken as a license to operate under any existing patents.

Компания «Life Electronics» занимается поставками электронных компонентов импортного и отечественного производства от производителей и со складов крупных дистрибьюторов Европы, Америки и Азии.

С конца 2013 года компания активно расширяет линейку поставок компонентов по направлению коаксиальный кабель, кварцевые генераторы и конденсаторы (керамические, пленочные, электролитические), за счёт заключения дистрибьюторских договоров

Мы предлагаем:

- Конкурентоспособные цены и скидки постоянным клиентам.
- Специальные условия для постоянных клиентов.
- Подбор аналогов.
- Поставку компонентов в любых объемах, удовлетворяющих вашим потребностям.
- Приемлемые сроки поставки, возможна ускоренная поставка.
- Доставку товара в любую точку России и стран СНГ.
- Комплексную поставку.
- Работу по проектам и поставку образцов.
- Формирование склада под заказчика.
- Сертификаты соответствия на поставляемую продукцию (по желанию клиента).
- Тестирование поставляемой продукции.
- Поставку компонентов, требующих военную и космическую приемку.
- Входной контроль качества.
- Наличие сертификата ISO.

В составе нашей компании организован Конструкторский отдел, призванный помогать разработчикам, и инженерам.

Конструкторский отдел помогает осуществить:

- Регистрацию проекта у производителя компонентов.
- Техническую поддержку проекта.
- Защиту от снятия компонента с производства.
- Оценку стоимости проекта по компонентам.
- Изготовление тестовой платы монтаж и пусконаладочные работы.



Тел: +7 (812) 336 43 04 (многоканальный)
Email: org@lifeelectronics.ru