

SPDT SWITCH GaAs MMIC

■GENERAL DESCRIPTION

NJG1512V is a GaAs SPDT switch IC featuring high isolation and low insertion loss.

This switch allows low operating voltage from 2.5V at the wide frequency range from 1MHz to 3GHz.

NJG1512V is suitable to switch the synthesizer signals between transmit and receiving circuit.

A very small SSOP package is adopted.

■PACKAGE OUTLINE

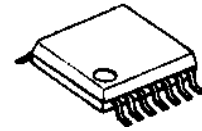

NJG1512V

■FEATURES

- Single, low voltage control +2.5~+5.5V
- High isolation 46dB typ. @f=0.05~2GHz, P_{in}=0dBm
- Low insertion loss 0.8dB typ. @f=2GHz, P_{in}=0dBm
- Low current consumption 2uA typ. @f=0.05~2.5GHz, P_{in}=10dBm
- Package SSOP14 (Mount Size: 6.4x5.0x1.25mm)

■PIN CONFIGURATION

V Type
(Top View)

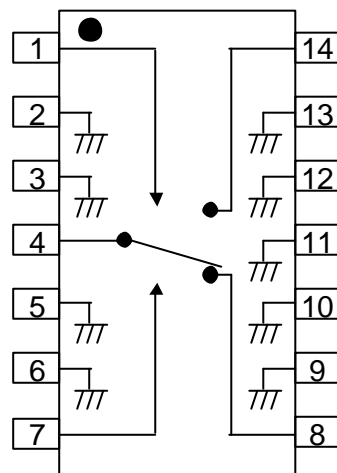

Pin Connection

1. V_{CTR2}
2. GND
3. GND
4. PC
5. GND
6. GND
7. V_{CTR1}
8. P1
9. GND
10. GND
11. GND
12. GND
13. GND
14. P2

■TRUTH TABLE

“H”=V_{CTR (H)}, “L”=V_{CTR (L)}

V _{CTR1}	H	L	L	H
V _{CTR2}	L	H	L	H
PC-P1	OFF	ON	*1	
PC-P2	ON	OFF		

*1) Combinations of V_{CTR1}/V_{CTR2}=L/L, H/H are not available.

NJG1512V

■ABSOLUTE MAXIMUM RATINGS

($T_a=25^{\circ}\text{C}$, $Z_s=Z_l=50\Omega$)

PARAMETER	SYMBOL	RATINGS	UNITS
Input Power	P_{in}	27	dBm
Control Voltage	V_{CTR}	6.0	V
Power Dissipation	P_D	600	mW
Operating Temp.	T_{opr}	-20~+85	$^{\circ}\text{C}$
Storage Temp.	T_{stg}	-40~+150	$^{\circ}\text{C}$

■ELECTRICAL CHARACTERISTICS 1

(TEST CIRCUIT 1: $V_{CTR(L)}=0\text{V}$, $V_{CTR(H)}=2.7\text{V}$, $Z_s=Z_o=50\Omega$, $T_a=25^{\circ}\text{C}$)

PARAMETER	SYMBOL	CONDITIONS	MIN	TYP	MAX	UNITS
Control voltage (L)	$V_{CTR(L)}$	$f=0.05\sim 2.5\text{GHz}$, $P_{in}=10\text{dBm}$	-0.2	0	0.2	V
Control voltage (H)	$V_{CTR(H)}$	$f=0.05\sim 2.5\text{GHz}$, $P_{in}=10\text{dBm}$	2.5	2.7	5.5	V
Control current	I_{CTR}	$f=0.05\sim 2.5\text{GHz}$, $P_{in}=10\text{dBm}$	-	2.0	4.0	μA
Isolation	ISL1	$f=0.05\sim 2.0\text{GHz}$, $P_{in}=0\text{dBm}$	43	46	-	dB
Insertion loss 1	LOSS1	$f=1.0\text{GHz}$, $P_{in}=0\text{dBm}$	-	0.6	1.0	dB
Insertion loss 2	LOSS2	$f=2.0\text{GHz}$, $P_{in}=0\text{dBm}$	-	0.8	1.2	dB
Pin at 1dB compression point	$P_{-1\text{dB}}$	$f=2.0\text{GHz}$	19.0	22.0	-	dBm
VSWR	VSWR	$f=0.05\sim 2.5\text{GHz}$, ON STATE	-	1.2	1.8	
Switching time	T_{SW}	$f=0.05\sim 2.5\text{GHz}$	-	8	-	ns

■ELECTRICAL CHARACTERISTICS 2

(TEST CIRCUIT 2: $V_{CTR(L)}=0\text{V}$, $V_{CTR(H)}=2.7\text{V}$, $Z_s=Z_o=50\Omega$, $T_a=25^{\circ}\text{C}$)

PARAMETER	SYMBOL	CONDITIONS	MIN	TYP	MAX	UNITS
Isolation 2	ISL2	$f=1\sim 100\text{MHz}$, $P_{in}=0\text{dBm}$	-	55	-	dB
Insertion loss 3	LOSS3	$f=1\sim 100\text{MHz}$, $P_{in}=0\text{dBm}$	-	0.5	-	dB

■ TYPICAL CHARACTERISTICS

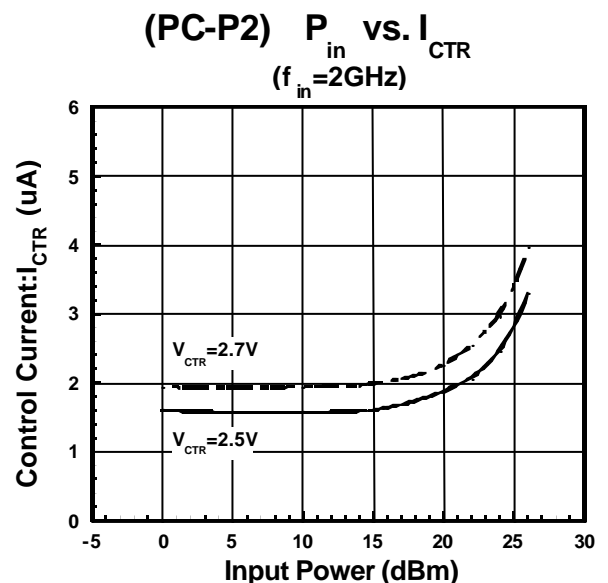
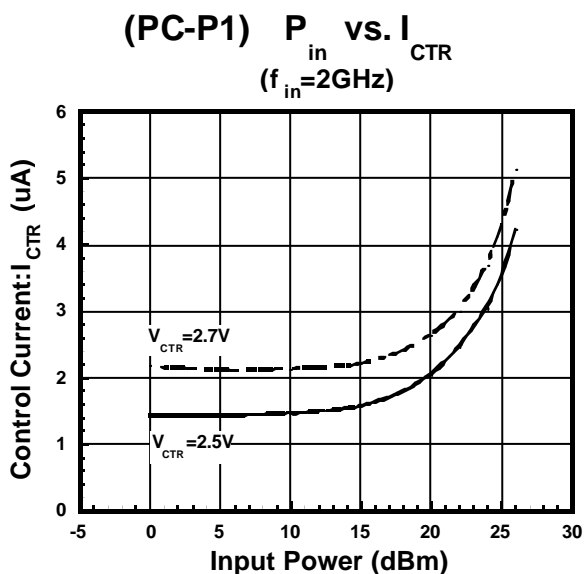
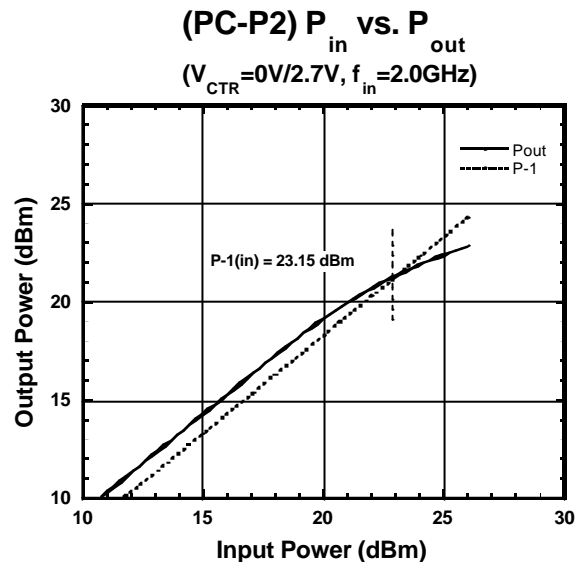
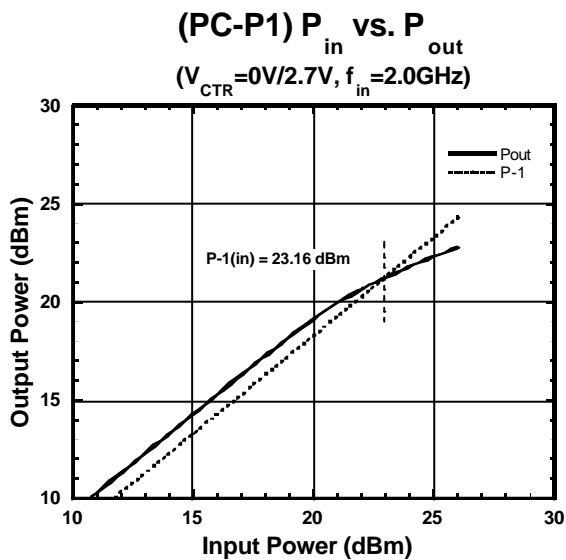
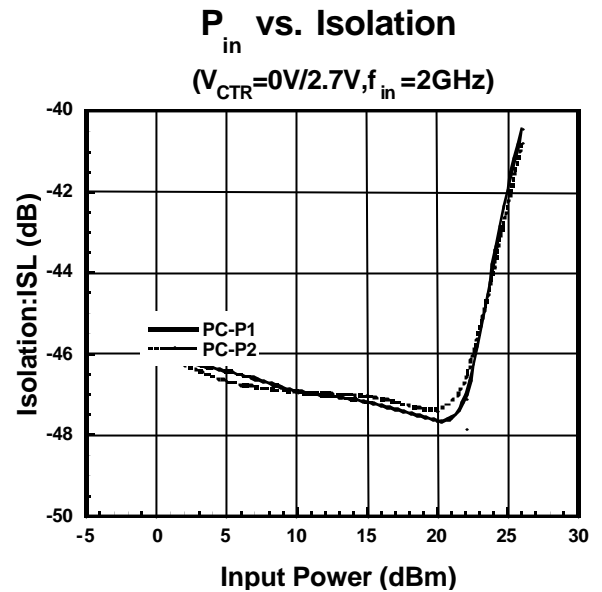
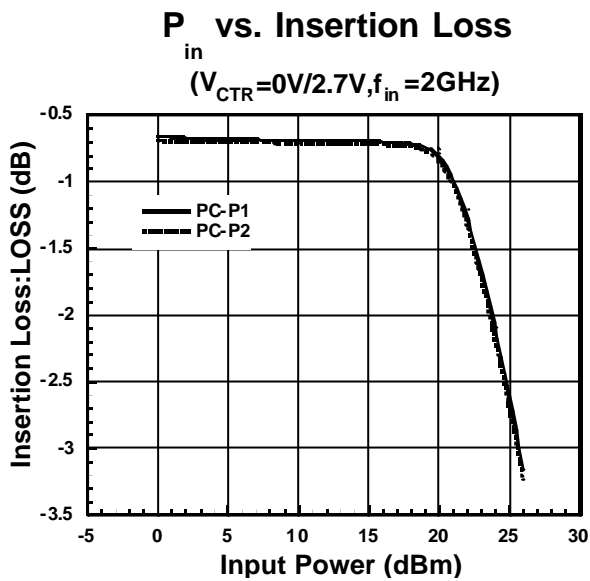

■ TYPICAL CHARACTERISTICS

PC-P1 Isolation

1-100MHz
($V_{CTR}=0V/2.7V$)

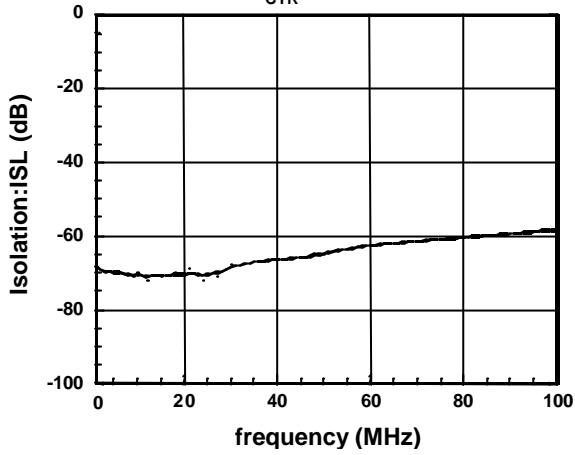

PC-P2 Isolation

1-100MHz
($V_{CTR}=0V/2.7V$)

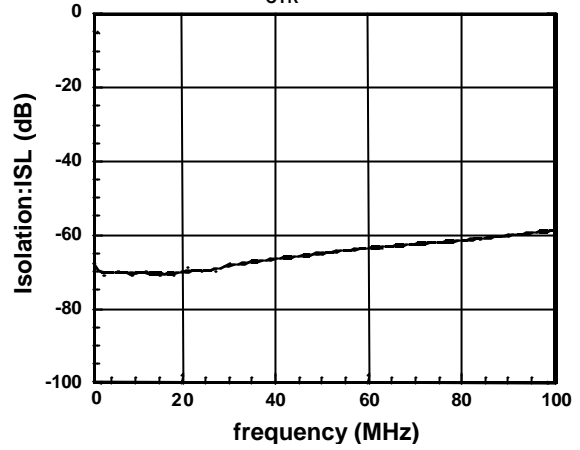

PC-P1 Insertion Loss

1-100MHz
($V_{CTR}=0V/2.7V$)

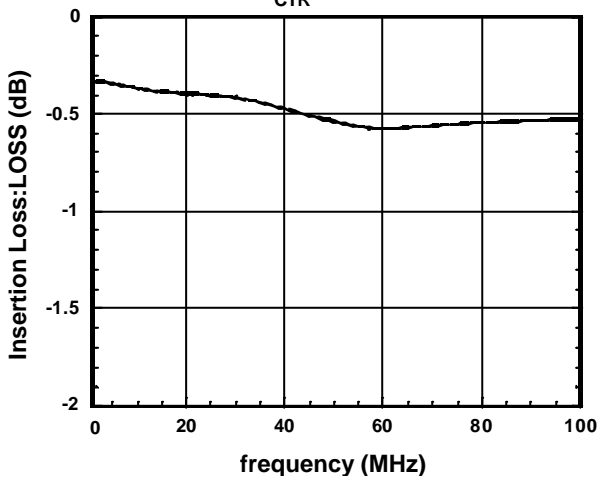

PC-P2 Insertion Loss

1-100MHz
($V_{CTR}=0V/2.7V$)

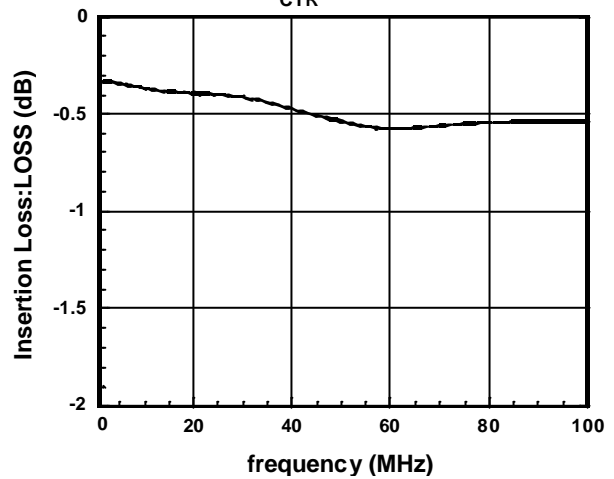

■ TYPICAL CHARACTERISTICS

PC-P1 Isolation

0.1-3GHz
($V_{CTR} = 0V/2.7V$)

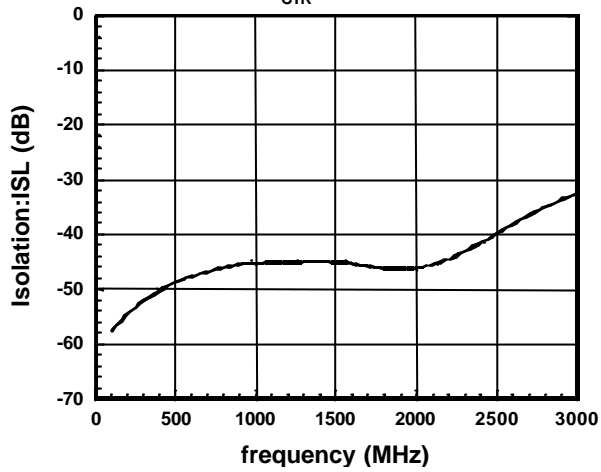

PC-P2 Isolation

0.1-3GHz
($V_{CTR} = 0V/2.7V$)

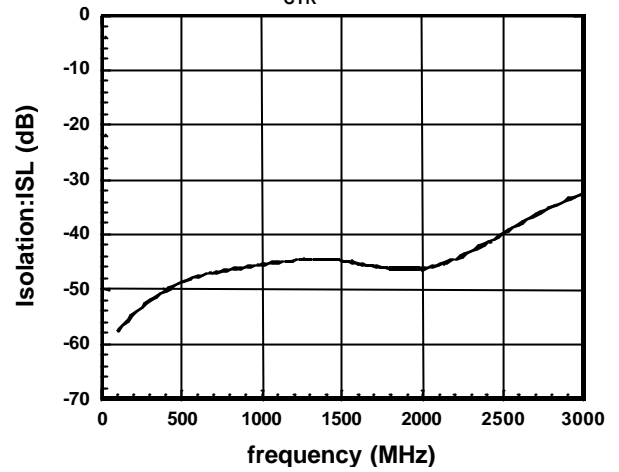

PC-P1 Insertion Loss

0.1-3GHz
($V_{CTR} = 0V/2.7V$)

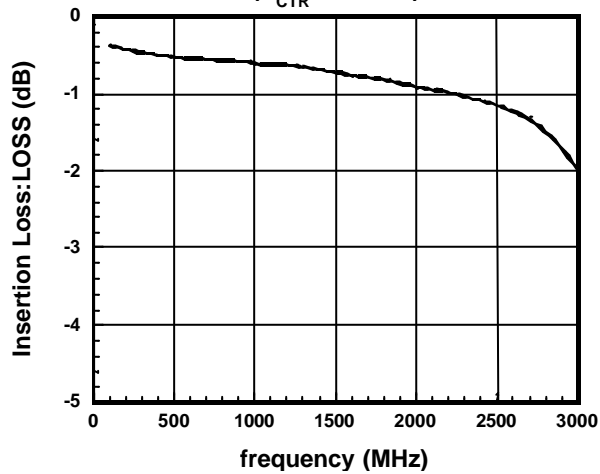

PC-P2 Insertion Loss

0.1-3GHz
($V_{CTR} = 0V/2.7V$)

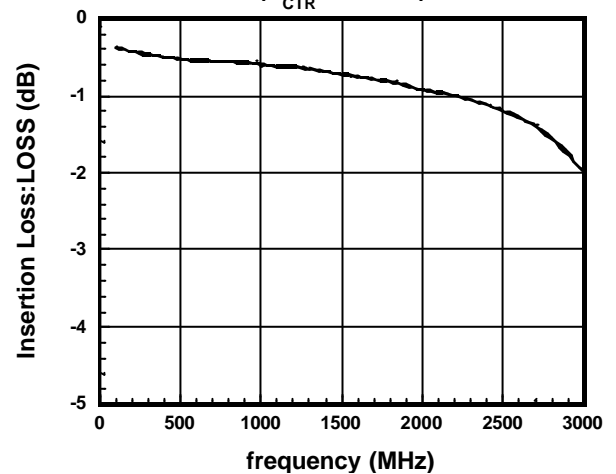

NJG1512V

■APPLICATION CIRCUIT: Single control signal operation by using C-MOS inverter
(frequency range: 0.1~2.0GHz)

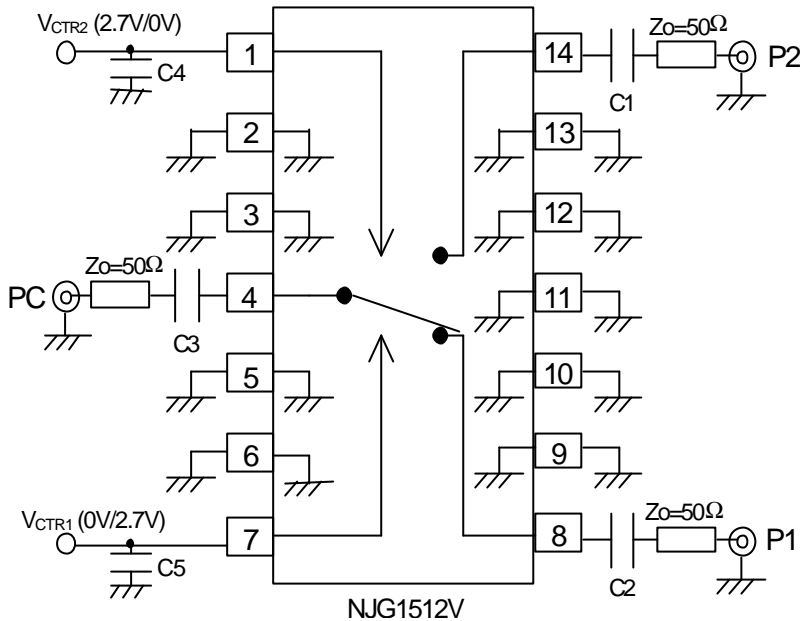

	Test circuit 1 0.5~2GHz	Test circuit 2 1~500MHz
C1~C3	56pF	0.1uF
C4, C5	10pF	1000pF

■RECOMMENDED PCB DESIGN

(TOP VIEW)

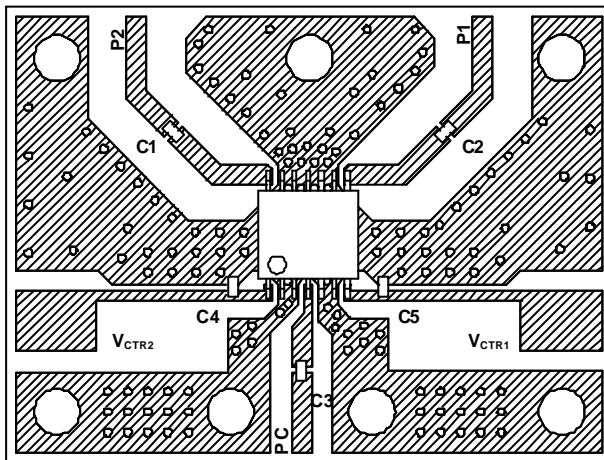

PCB SIZE=30.0x22.5mm
PCB: FR-4, t=0.5mm
STRIPLINE WIDTH =1mm
CAPACITOR: size 1005

PRECAUTIONS

- [1] The external capacitors should be connected to the input and output RF terminals (P₁, P₂, P_C) to block DC current. Please use a 0.01uF capacitor at 50 to 100MHz, a 0.1uF capacitor at 100 to 500MHz, and 56pF at 500MHz to 2.0GHz.
- [2] To avoid coupling between terminals, the capacitors have to be placed at the control terminals (V_{CTR1}, V_{CTR2}) as close as possible. The capacitor values of 0.01uF at 50 to 100MHz, 100pF at 100 to 500MHz, and 10pF at 500MHz to 2GHz are desired. In general, the switching time is depend on the capacitor values, so please be careful choosing capacitor values.
- [3] For good isolation characteristics, the ground terminals (2, 3, 5, 6, 9~13 pin) should be directly connected to the ground patterns and through-holes as close as possible using relatively wide patterns.

■APPLICATION CIRCUIT 1: Single control signal operation by using C-MOS inverter
(frequency: 0.1~2.0GHz)

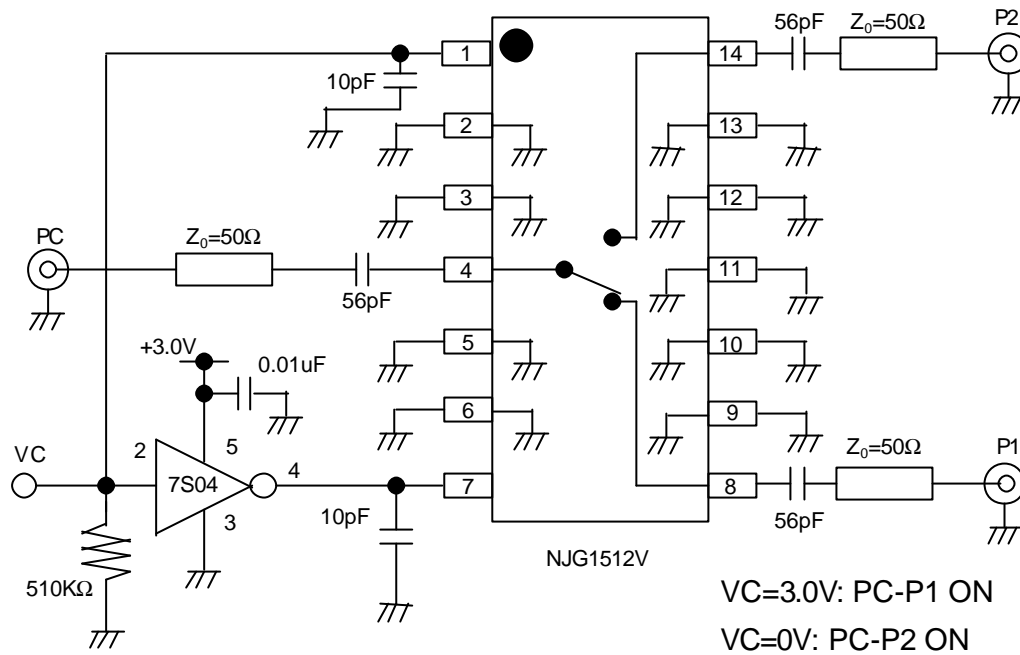

- [1]Please connect the bypass capacitor to the power supply terminal of the C-MOS inverter.
[2]In order to stabilize the input impedance of inverter, the input terminal of the C-MOS inverter should be pulled down by the resistor of 510KΩ to the ground plane.

NJG1512V

APPLICATION CIRCUIT 2: High Isolation SPDT Switch

(PA to PC, PB to PC, and PA to PB Isolation are greater than 70dB@fin=0.7~2GHz)

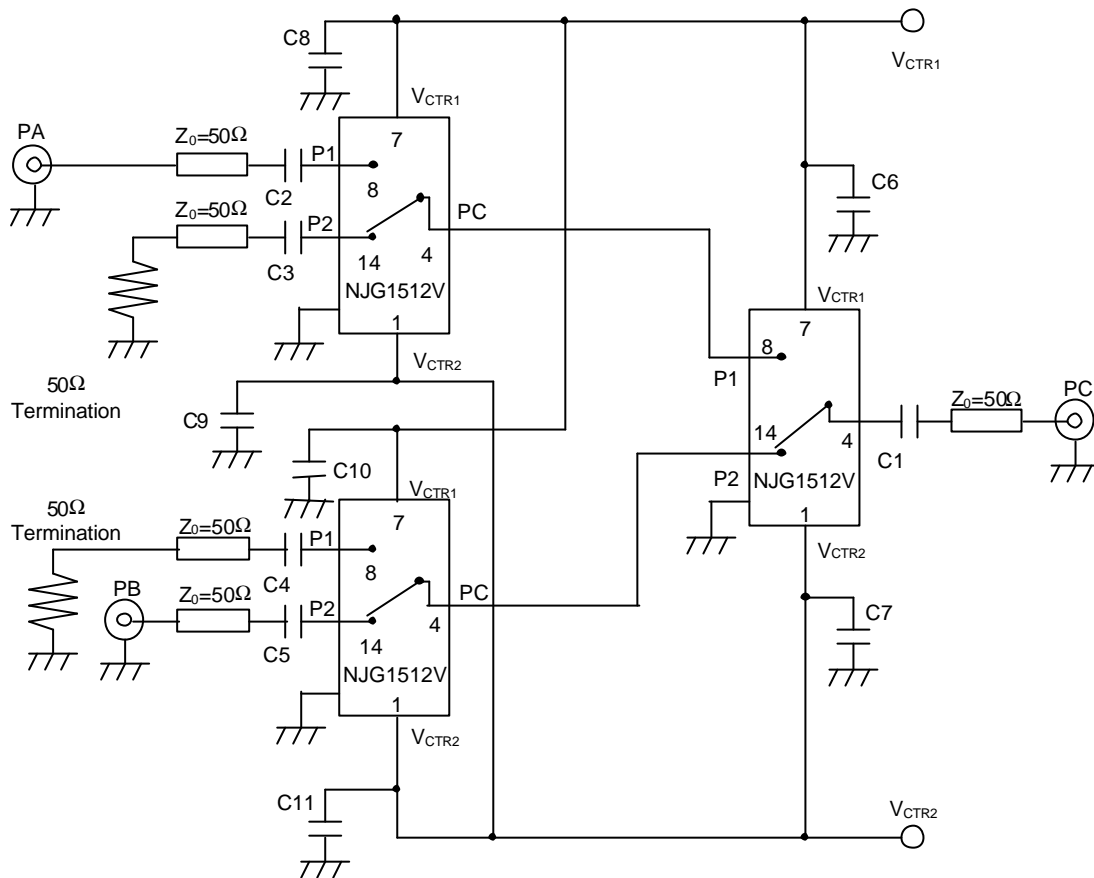

PCB DESIGN

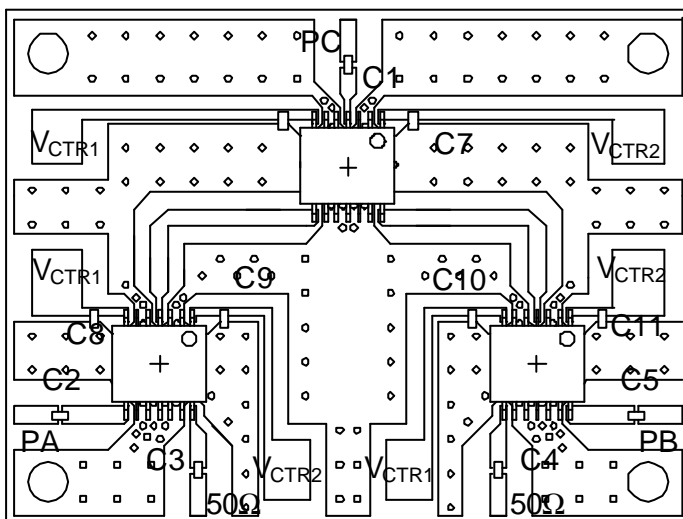

PCB SIZE=40.0x30.0mm
 PCB: FR-4 t=0.5mm
 STRIPLINE WIDTH=1mm
 CAPACITOR: size 1005
 C1~C5: 56pF
 C6~C11: 10pF

NOTE: As shown in the schematic above, the two 50Ω ports should be terminate externally.

■PACKAGE OUTLINE (SSOP14)

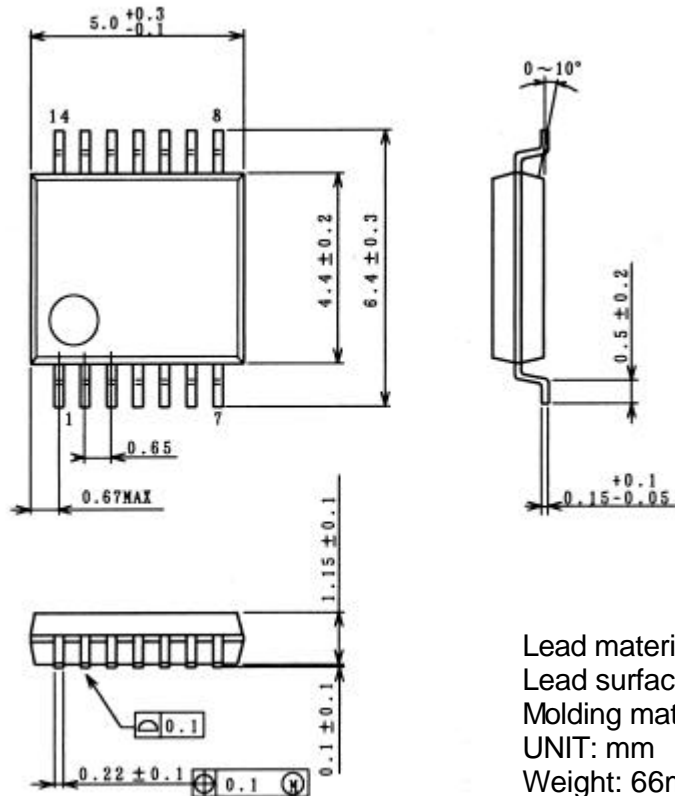

Lead material: Copper
 Lead surface finish: Solder plating
 Molding material: Epoxy resin
 UNIT: mm
 Weight: 66mg

Cautions on using this product

This product contains Gallium-Arsenide (GaAs) which is a harmful material.

- Do NOT eat or put into mouth.
- Do NOT dispose in fire or break up this product.
- Do NOT chemically make gas or powder with this product.
- To waste this product, please obey the relating law of your country.

[CAUTION]

The specifications on this databook are only given for information, without any guarantee as regards either mistakes or omissions. The application circuits in this databook are described only to show representative usages of the product and not intended for the guarantee or permission of any right including the industrial rights.

This product may be damaged with electric static discharge (ESD) or spike voltage. Please handle with care to avoid these damages.

Компания «Life Electronics» занимается поставками электронных компонентов импортного и отечественного производства от производителей и со складов крупных дистрибьюторов Европы, Америки и Азии.

С конца 2013 года компания активно расширяет линейку поставок компонентов по направлению коаксиальный кабель, кварцевые генераторы и конденсаторы (керамические, пленочные, электролитические), за счёт заключения дистрибьюторских договоров

Мы предлагаем:

- Конкуренспособные цены и скидки постоянным клиентам.
- Специальные условия для постоянных клиентов.
- Подбор аналогов.
- Поставку компонентов в любых объемах, удовлетворяющих вашим потребностям.
- Приемлемые сроки поставки, возможна ускоренная поставка.
- Доставку товара в любую точку России и стран СНГ.
- Комплексную поставку.
- Работу по проектам и поставку образцов.
- Формирование склада под заказчика.
- Сертификаты соответствия на поставляемую продукцию (по желанию клиента).
- Тестирование поставляемой продукции.
- Поставку компонентов, требующих военную и космическую приемку.
- Входной контроль качества.
- Наличие сертификата ISO.

В составе нашей компании организован Конструкторский отдел, призванный помогать разработчикам, и инженерам.

Конструкторский отдел помогает осуществить:

- Регистрацию проекта у производителя компонентов.
- Техническую поддержку проекта.
- Защиту от снятия компонента с производства.
- Оценку стоимости проекта по компонентам.
- Изготовление тестовой платы монтаж и пусконаладочные работы.



Тел: +7 (812) 336 43 04 (многоканальный)

Email: org@lifeelectronics.ru