



## Four Bi-Directional Channel Fiber Optic Media Converter

CTF-4G-4TXRX

### FEATURES

- + Built around a rugged and high technology readiness level (TRL) quad channel bi-directional transceiver
  - Four copper to fiber transmitters/receivers
  - Four optical to copper transmitters/receivers
- + For use with the DVI interface, has optional receive equalization and transmit pre-emphasis CDR
- + Standard serial interface for built-in test interface
- + For DVI fiber repeating, a single product to convert from copper to fiber and from fiber to copper concurrently
  - Copper DVI input and output channels connect to unit via standard MIL-DTL-38999 connectors and high speed quadrax sockets
  - Fiber DVI input and output channels connect to unit via a standard MIL-DTL-38999 connector with M29504 fiber optic termini sockets
- + 28 V DC power input for low power operation on a standard MIL-DTL-38999 connector
- + Built upon Amphenol low risk and affordable CTF copper to fiber converter product line

### CONTACT US:

Jared Sibrava

E-mail: [jsibrava@amphenol-aao.com](mailto:jsibrava@amphenol-aao.com)

Phone: 607-643-1845

### OVERVIEW

The CTF-4G-4TXRX Media Converter is an integrated, standalone, convection cooled, and rugged fiber to copper and copper to fiber converter for use with Gigabit Ethernet, Fiber Channel, Infiniband, Digital Video Interface (DVI), and many other interfaces.

### FIBER INTERFACE

The CTF-4G-4TXRX uses industry standard M29504/5 fiber termini.

### COPPER INTERFACE

The Quadrax inputs can utilize Split-Pair Quadrax versus standard quadrax. The contacts are rated for 6.5Gbps versus 3.125Gbps

### RUGGEDIZATION

The CTF-4G-4TXRX Media Converter is Natural convection cooled, so there is no fan. The operational temperature is -40°C to +85°C, and the converter is environmentally sealed.



# Four Bi-Directional Channel Fiber Optic Media Converter CTF-4G-4TXRX

## Drawing

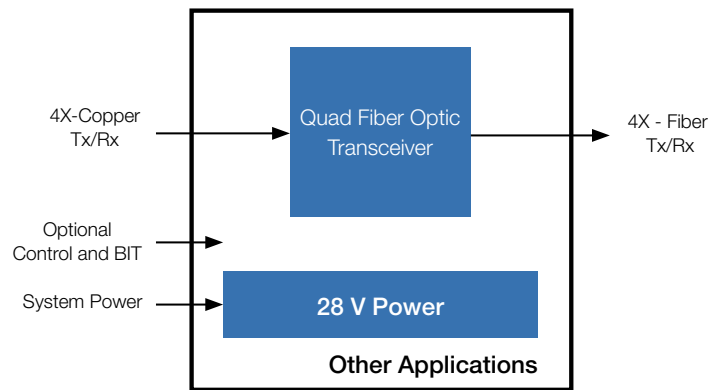
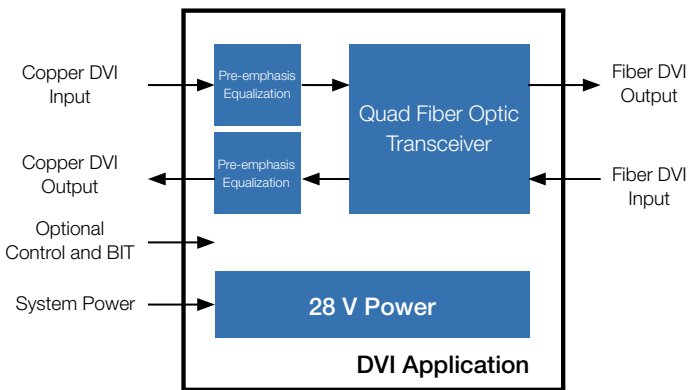
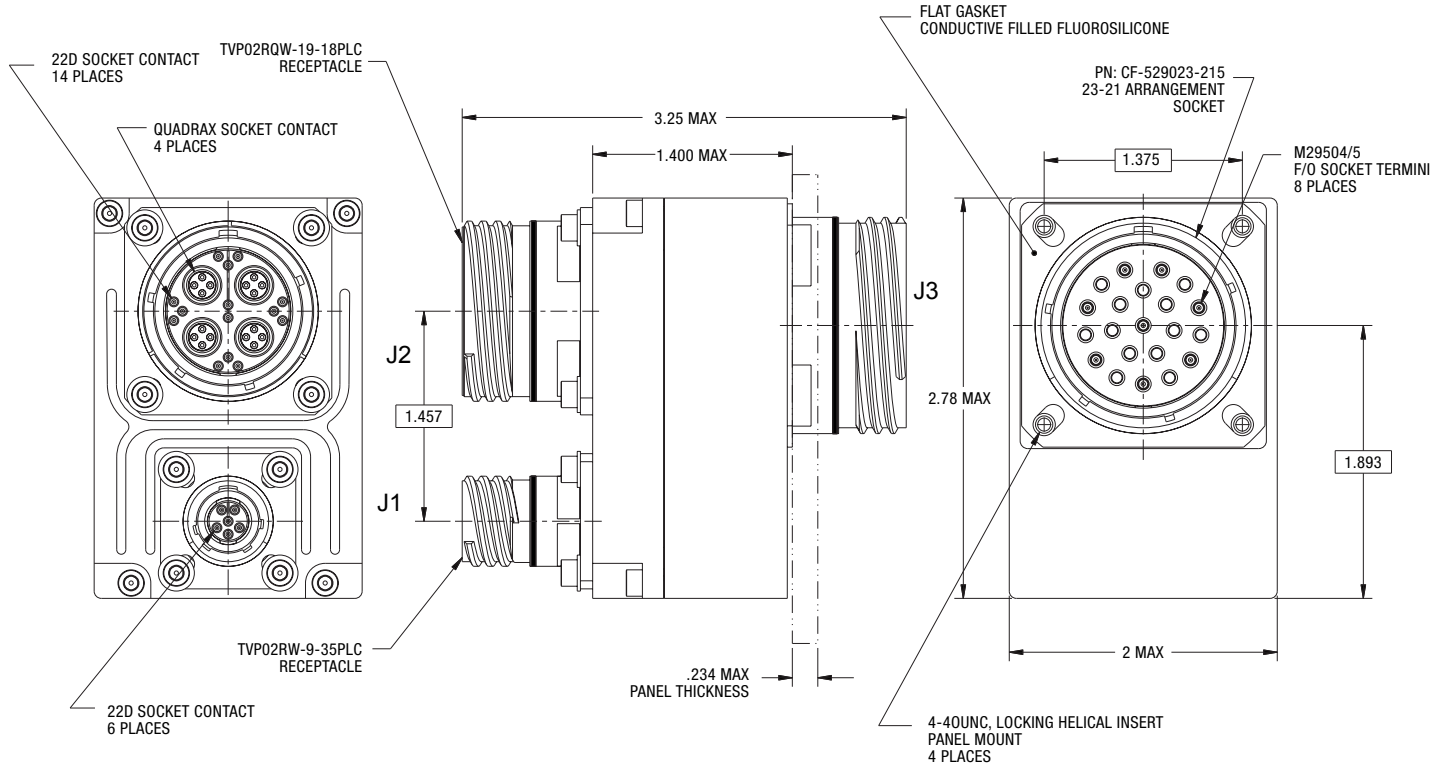

CONTACT US:

Jared Sibrava

E-mail: jsibrava@amphenol-aa.com

Phone: 607-643-1845

## How to Order

Ordering procedure is shown below using part number CTF-

1.	2.	3.	4.	5.	6.	7.	8.
Connector Type	Material	Quadrax Contact	Finish	Shell Style	Copper DVI Keying	Power Connector Keying	Fiber Connector Keying
CTF	-5	Q	Z	0	-A	B	C

### Step 1. Connector Type

	Designates
CTF	Copper to Fiber Media Conversion Family

### Step 2. Select a Material

	Designates
-5	Aluminum Shell
-6	Composite Shell
-8	Stainless Steel Shell

### Step 3. Quadrax Configuration

	Designates
Q	3.125 GB Quadrax Sockets for copper DVI inputs and outputs
S	6.5 GB Split-Pair Quadrax Sockets

### Step 4. Select a Finish

	Designates
T	Aluminum Durmalon
Z	Aluminum Black Zinc Nickel
F	Aluminum Electroless Nickel
M	Composite Electroless Nickel
W	Aluminum OD Cad
J	Composite OD Cad
L	Stainless Steel Electrodeposited Nickel
Y	Stainless Steel Passivated

### Step 5. Select a Shell Style

	Designates
0	Wall Mount

### Step 6. Select Copper DVI Connector Keying (IAW MIL-DTL-38999)

	Designates
N	N
A	A
B	B
C	C
D	D
E	E

### Step 7. Select Power Connector Keying (IAW MIL-DTL-38999)

	Designates
N	N
A	A
B	B
C	C
D	D
E	E

### Step 8. Select Fiber Connector Keying (IAW MIL-DTL-38999)

	Designates
N	N
A	A
B	B
C	C
D	D
E	E

### Available Test Equipment

Part Number	Description
CF-901201-007	LC Fiber Optic Test Cable for D38999 Connector
CA-628485-A42	Power Test Cable for D38999 Power Connector
CA-628485-A43	High Speed Copper SMA Cable for D38999 Data Connector

CONTACT US:

Jared Sibrava

E-mail: jsibrava@amphenol-ao.com

Phone: 607-643-1845

## Specifications

### Absolute Maximum Ratings

Stress beyond the values stated below may cause permanent damage to the device.

Parameter	Symbol	Min	Max	Unit	Notes
Storage temperature	Tst	-55	+125	°C	-
Soldering temperature	Tsol	-	230	°C	-
Soldering Time	tsol	-	60	s	-
Supply voltage range	VcCTx, VCCRx	-0.3	+4.0	V	-
Signal pins voltage range	Vpin	V.EEX-0.3	V.ccx.+0.3	V	-
Differential input voltage	$\Delta V_{in}$	-	1.2	V	-
Junction temperature	Tj	-	130	°C	-
ESD resistance voltage	ESD	-	1	KV	-

### Module Specifications-General

Parameter	Symbol	Min	Typ	Max	Unit	Notes
Supply voltage	VccTx, VCCRx	3.0	3.3	3.6	V	-
Supply voltage noise	Nvccx	-	-	100	mV	-
Supply current (Tx + Rx)	Icc	-	275	300	mA	1
Power consumption (Tx + Rx)	P	-	900	1000	mW	1
Data Rate	B	0.001	2.5	3.125	Gbps	-
Operating temperature	Top	-40	-	+85	°C	2

CONTACT US:

Jared Sibrava

E-mail: [jsibrava@amphenol-ao.com](mailto:jsibrava@amphenol-ao.com)

Phone: 607-643-1845

**Module Specifications-Electrical**

Parameter	Symbol	Min	Typ	Max	Unit	Notes
Number of TX or Rx channels	Nch	2	-	4	-	-
Transmitter (one channel)						
Input voltage range	V <sub>IN</sub>	V <sub>EE</sub> + 0.825		V <sub>CC</sub> +0.2	V	
Differential input voltage	V <sub>INpp</sub>	100	-	950	mV	-
Input impedance	Z <sub>IN</sub>	80	100	120	Ω	-
Input capacitance (each input)	C <sub>IN</sub>	1.0	1.3	1.6	pF	-
Digital inputs	High	V <sub>high</sub>	0.7xV <sub>CC</sub>	-	V <sub>CC</sub> +0.3	V
	Low	V <sub>low</sub>	V <sub>EE</sub> -0.3	-	0.3xV <sub>CC</sub>	V
Tx supply current	I <sub>CC</sub> Tx	-	150	160	mA	-
Receiver (one channel)						
Differential output voltage	V <sub>OUTp</sub>	100	250	350	mV	-
Output impedance	Z <sub>out</sub>	80	100	120	Ω	-
Output CML drive current	I <sub>o</sub>	-	12	-	mA	
Average proportional photocurrent output	I <sub>avg</sub>	0	-	160	μA	1,2
Total jitter receiver	T <sub>JRx</sub>	-	60	150	ps	-
Rise/Fall Time	T <sub>R</sub> Rx, T <sub>F</sub> Rx	-	80	150	ps	3
Rx supply current	I <sub>CC</sub> Rx	-	125	140	mA	-

**Module Specifications-Optical**

Parameter	Symbol	Min	Typ	Max	Unit	Notes
Transmitter (one channel)						
Center wavelength	λ <sub>C</sub>	840	850	860	nm	-
Spectral width-rms	Δλ	-	-	0.85	nm	-
Core diameter of the Tx optical fiber pigtail	D <sub>C</sub>	50	62.5	-	μm	-
Optical output power (average)	P <sub>out</sub>	-5	-3	+1	dBm	1,2,3
Optical output power variation over the specified temperature range	ΔP <sub>out</sub>	-	0.5	1	dB	3,4
Optical modulation amplitude	OMA <sub>Tx</sub>	650	-	-	μW	-
Optical extinction ratio	E <sub>R</sub>	7.0	9.0	-	dB	-
Relative intensity Noise	RIN	-	-	-117	dB/Hz	-
Total jitter		-	60	150	ps	-
Rise/Fall time	τ <sub>R</sub> , τ <sub>F</sub>	-	80	150	ps	5
Receiver (one channel)						
Center wavelength	λ <sub>C</sub>	760	850	860	nm	-
Spectral width-rms	Δλ	-	-	1	nm	-
Core diameter of the Rx optical fiber pigtail	D <sub>C</sub>	50	-	62.5	μm	-
Optical sensitivity	P <sub>in</sub>	-21	-19	-17	dBm	6
Optical modulation amplitude	OMA <sub>Rx</sub>	-	-	-	μW	-
Optical return loss	ORL	-30	-	-	dB	-

CONTACT US:

Jared Sibrava

E-mail: jsibrava@amphenol-ao.com

Phone: 607-643-1845

## Overview

Amphenol integrated electronic products are designed and manufactured to our Ruggedization guidelines listed below. These guidelines ensure years of reliable operation in harsh environment applications where extreme operating temperatures, shock, vibration and corrosive atmospheres are regularly experienced

## Temperature

- Operating Temperature - Thermal Cycles between -40°C and 85°C while device is operating
- Temperature is measured at chassis housing or card edge
- Storage Temperature - Thermal Cycles between -55°C and 125°C

## Humidity

- Operating Humidity – Humidity cycle between 0-100% non-condensing humidity while device is operating
- Storage Humidity – Humidity cycle between 0-100% condensing humidity

## Sealing

- Sealing can be optionally provided at the MIL-DTL-38999 interface with up to 10-5 cc/sec performance

## Fluids Susceptibility

- MIL-DTL-38999 receptacle interface per EIA-364-10E

## Vibration & Shock

- Sine Vibration – 10 g Peak, 5-2,000Hz
  - Based on a sine sweep duration of 10 minutes per axis in each of three mutually perpendicular axes. May be displacement limited from 5 to 44 Hz, depending on specific test.
- Random Vibration - 0.005@5Hz, 0.1@15Hz, 0.1@2,000Hz
  - 60 minutes per axis, in each of three mutually perpendicular axes.
- 40 G Peak Shock Cycle
  - Three hits in each axis, both directions, ½ sine and terminal-peak saw tooth, Total 36 hits.

## Altitude

- -1,500 to 60,000 ft Altitude Testing w/ Rapid Depressurization

## Electromagnetic Compatibility

- Designed to comply with MIL-STD-461E

## Printed Circuit Board Assemblies

- Conformal Coat
  - Amphenol performs Conformal Coating to both sides of printed circuit board assemblies using HUMISEAL IB31 in accordance with IPC-610, Class 3.
- Printed Circuit Board Rigidity
  - Amphenol printed circuit boards are fabricated in accordance with IPC-6012, Class 3.
- Printed Circuit Board Fabrication
  - Amphenol printed circuit boards acceptance criteria is in accordance with IPC-610, Class 3.

## Reliability Predictions (MTBF)

Amphenol can perform Mean Time Between Failure (MTBF) reliability analysis in full compliance with MIL-HDBK-217F-1 Parts Count Prediction and MIL-HDBK-217F-1 Parts Stress Analysis Prediction. We can also perform reliability analyses in full compliance of ANSI/VITA 51.1 if it is required or preferred over the later method.

## CONTACT US:

Jared Sibrava

E-mail: [jsibrava@amphenol-aa0.com](mailto:jsibrava@amphenol-aa0.com)

Phone: 607-643-1845

**Notice:** Specifications are subject to change without notice. Contact your nearest Amphenol Corporation Sales Office for the latest specifications. All statements, information and data given herein are believed to be accurate and reliable but are presented without guarantee, warranty, or responsibility of any kind, expressed or implied. Statements or suggestions concerning possible use of our products are made without representation or warranty that any such use is free of patent infringement and are not recommendations to infringe any patent. The user should assume that all safety measures are indicated or that other measures may not be required. Specifications are typical and may not apply to all connectors.

AMPHENOL is a registered trademark of Amphenol Corporation. ©2015 Amphenol Corporation REV:3/4/2015

6

Компания «Life Electronics» занимается поставками электронных компонентов импортного и отечественного производства от производителей и со складов крупных дистрибьюторов Европы, Америки и Азии.

С конца 2013 года компания активно расширяет линейку поставок компонентов по направлению коаксиальный кабель, кварцевые генераторы и конденсаторы (керамические, пленочные, электролитические), за счёт заключения дистрибьюторских договоров

Мы предлагаем:

- Конкурентоспособные цены и скидки постоянным клиентам.
- Специальные условия для постоянных клиентов.
- Подбор аналогов.
- Поставку компонентов в любых объемах, удовлетворяющих вашим потребностям.
- Приемлемые сроки поставки, возможна ускоренная поставка.
- Доставку товара в любую точку России и стран СНГ.
- Комплексную поставку.
- Работу по проектам и поставку образцов.
- Формирование склада под заказчика.
- Сертификаты соответствия на поставляемую продукцию (по желанию клиента).
- Тестирование поставляемой продукции.
- Поставку компонентов, требующих военную и космическую приемку.
- Входной контроль качества.
- Наличие сертификата ISO.

В составе нашей компании организован Конструкторский отдел, призванный помогать разработчикам, и инженерам.

Конструкторский отдел помогает осуществить:

- Регистрацию проекта у производителя компонентов.
- Техническую поддержку проекта.
- Защиту от снятия компонента с производства.
- Оценку стоимости проекта по компонентам.
- Изготовление тестовой платы монтаж и пусконаладочные работы.



Тел: +7 (812) 336 43 04 (многоканальный)  
Email: [org@lifeelectronics.ru](mailto:org@lifeelectronics.ru)