

# Kinetis Microcontrollers

The most scalable portfolio of low power, mixed-signal MCUs based on the ARM Cortex-M4 architecture in the industry

November 4, 2010

Eduardo Montanez – Industrial & Multi-Market Systems Engineer

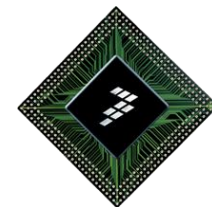

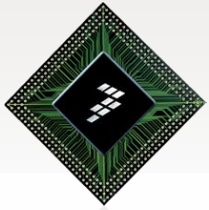

## ***Kinetis Revolution: Cortex-M4 Microcontroller Portfolio Powered with Innovative 90nm TFS Flash Technology by Freescale***

Freescale's 32-bit industrial and consumer microcontrollers are evolving into a new era with the launch of Kinetis. The first broad-market mixed signal microcontroller family based on the new ARM Cortex-M4 core and innovative 90nm thin-film storage (TFS) flash memory technology. With over 200 Kinetis MCUs, Freescale enables scalable performance, market-leading mixed-signal integration and ultra-low power consumption.

## **Agenda**

- ▶ Portfolio Overview
- ▶ Key Differentiators
- ▶ Enablement Solutions
- ▶ Application Use Cases
- ▶ Technical Deep Dive
- ▶ Kinetis Solution Demonstration





# New Kinetis MCUs

## Scalable Mixed-Signal Consumer and Industrial Microcontroller Families

The most **scalable** portfolio of **low-power ARM Cortex-M4** MCUs available today

Over **200** hardware and software compatible ARM Cortex-M4 devices with high performance **signal processing capability** and run currents of **<200uA/MHz**

Innovative Low Power **90nm Thin-Film Storage** Flash with **FlexMemory**

Offers **EEPROM capability** with unprecedented programming speed and endurance, capable of over **10 Million cycles**

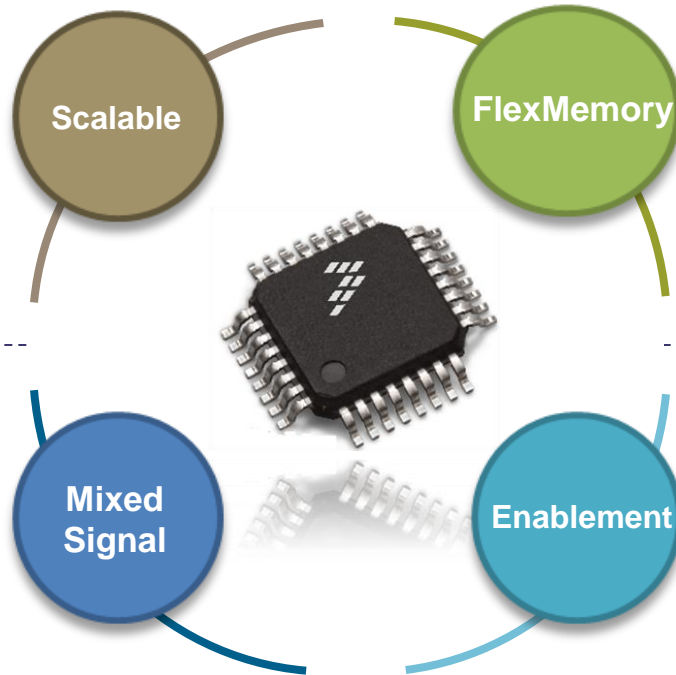

Exceptional **mixed-signal** integration

Flexible, High-speed, high-precision 16-bit **ADCs**, 12-bit **DACs**, Programmable Gain **Amplifiers**, Voltage References, and Hardware **Touch Sensing** lower system costs.

One of the most **comprehensive ARM® enablement** portfolios

**Complimentary Freescale MQX RTOS and Eclipse-based CodeWarrior 10.0 IDE**, as well as **IAR, KEIL** and other ARM ecosystem providers help speed time to market

More than **200 New Parts**  
7 scalable families

**First available broad-market MCU samples based on ARM Cortex-M4!**

# Kinetis Product Family Features

MCU Family	USB OTG (FS & HS)	Dual CAN	Ethernet (IEEE 1588)	Encryption (CAU+RNG)	NAND Flash Controller (120MHz, 150MHz, only)	Floating Point Unit (120MHz, 150MHz, only)	Hardware Tamper Unit	DRAM Controller (256 pin MAPBGA, only)
<b>K70 Family</b> 512KB-1MB, 196-256pin	●	●	●	●	●	●	●	●
<b>K60 Family</b> 256KB-1MB, 100-256pin	●	●	●	●	●	●	●	●
<b>K50 Family</b> 128-512KB, 64-144pin	●	●	●	●				
<b>K40 Family</b> 64-512KB, 64-144pin	●	●		●				
<b>K30 Family</b> 64-512KB, 64-144pin		●		●				
<b>K20 Family</b> 32KB-1MB, 32-144pin	●	●			●	●		
<b>K10 Family</b> 32KB-1MB, 32-144pin		●			●	●		

 Available Q4 2010

Common System IP	Common Analog IP	Common Digital IP	Development Tools
32-bit ARM Cortex-M4 Core w/ DSP Instructions	16-bit ADC	CRC	Bundled IDE w/ Processor Expert
Next Generation Flash Memory High Reliability, Fast Access		I <sup>2</sup> C	
FlexMemory w/ EEPROM capability	12-bit DAC	SAI (I <sup>2</sup> S)	Bundled OS USB, TCP/IP, Security
SRAM		UART/SPI	
Memory Protection Unit	High-speed Comparators	Programmable Delay Block	Modular Tower H/ware Development System
Low Voltage, Low Power Multiple Operating Modes, Clock Gating (1.71V-3.6V with 5V tolerant I/O)		External Bus Interface	
DMA		Motor Control Timers	
-40 to 105C	Low-power Touch Sensing	eSDHC	(Motor Control, HMI, USB)
		RTC	
			Broad 3rd party ecosystem

# An Unmatched Range of ARM Cortex-M4 Microcontrollers

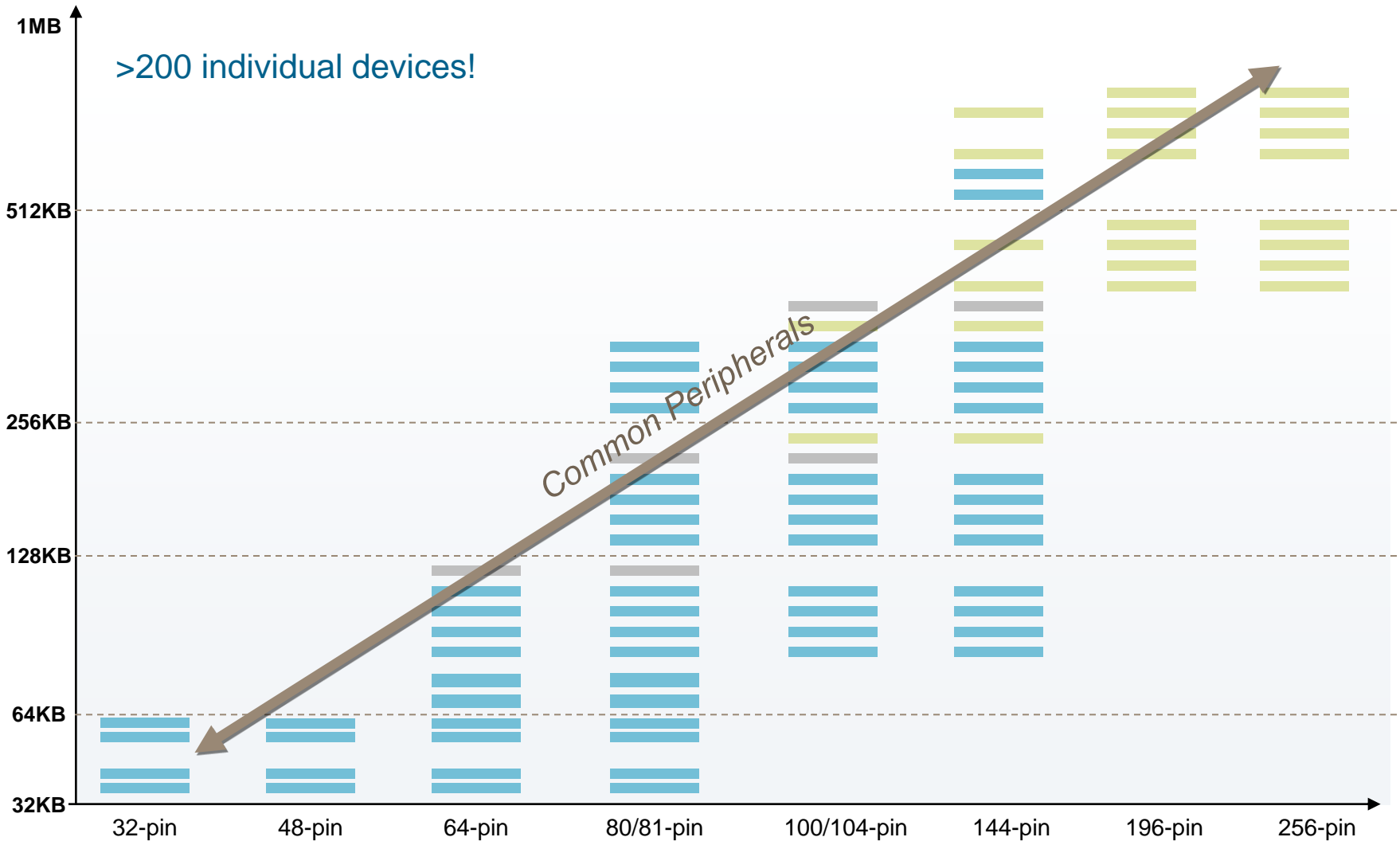

Multiple compatible families with scalable performance, memory and peripherals

# K10/K20 Family Block Diagram

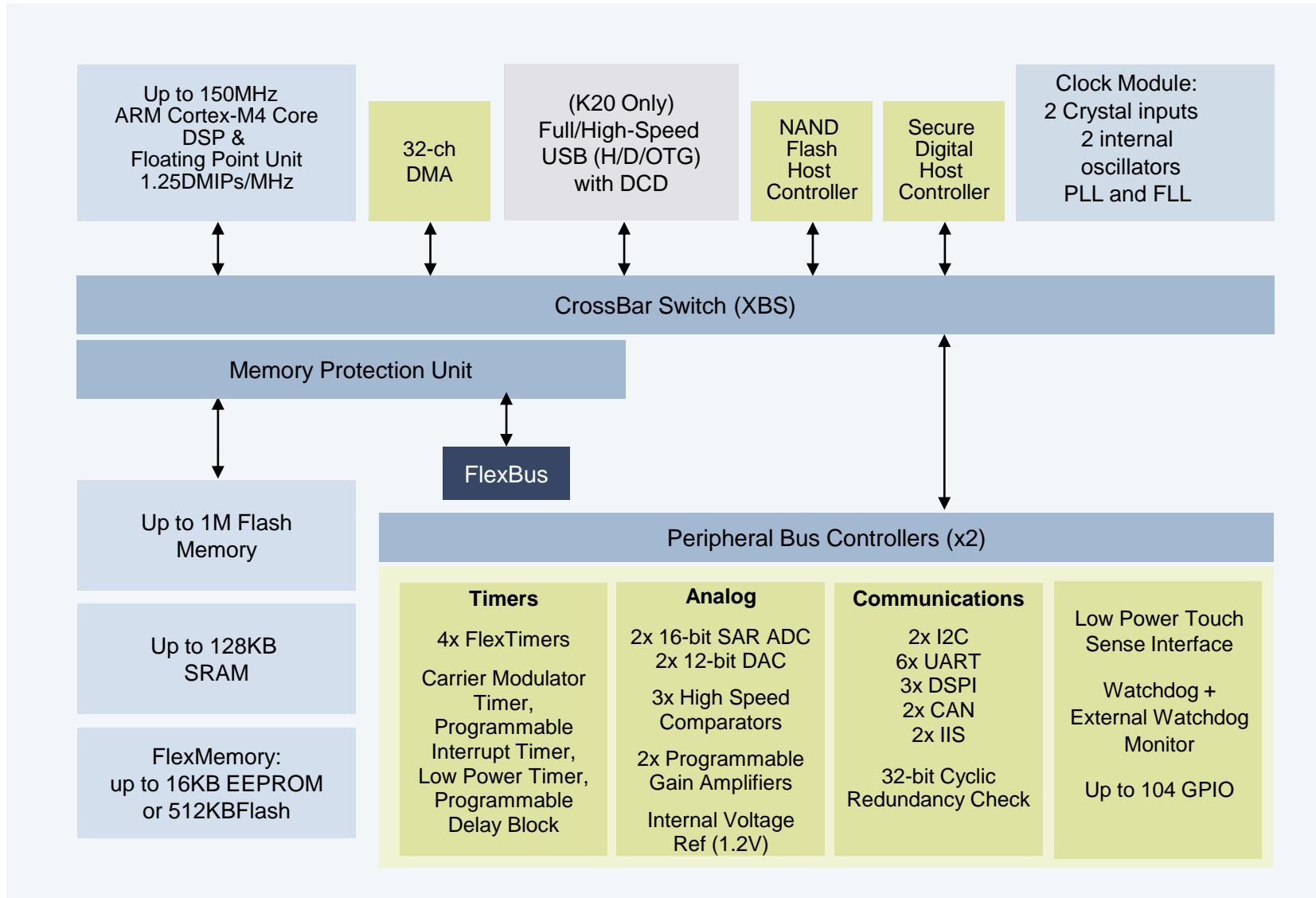

# K10/K20 Family Overview

## High Integration Mixed-Signal MCUs

### ▶ Processing Performance and FlexMemory

- Direct Memory Access, Cross Bar Switch, and on-chip Cache maximize bus bandwidth and Flash execution
- FlexMemory provides on-chip, high-endurance configurable EEPROM and/or additional Flash memory

### ▶ (K20 Only) Connect via USB AND charge a battery

- USB 2.0 Full-Speed Device/Host/OTG Controller with integrated transceiver, HS via ULPI interface
- Includes Device Charge Detector (DCD) and Regulator to supports battery charging via USB for Portable Devices

### ▶ Flexible and Powerful Mixed Signal Capability

- 16-bit ADC enables small signal capture for medical/sensing applications, or high speed conversions for motor control.
- 12-bit DAC, High-Speed Comparator, and Voltage Reference on-chip reduces system cost

### ▶ Ultra-low power with 1.71V operation

- Multiple low power modes and Flash & analog operation down to 1.71V – power profile optimization and prolonged battery life
- Stop Currents <500nA, run currents <200uA/MHz

**32KB Flash in 32 pin package  
starting at \$0.99 for 10K SRP**

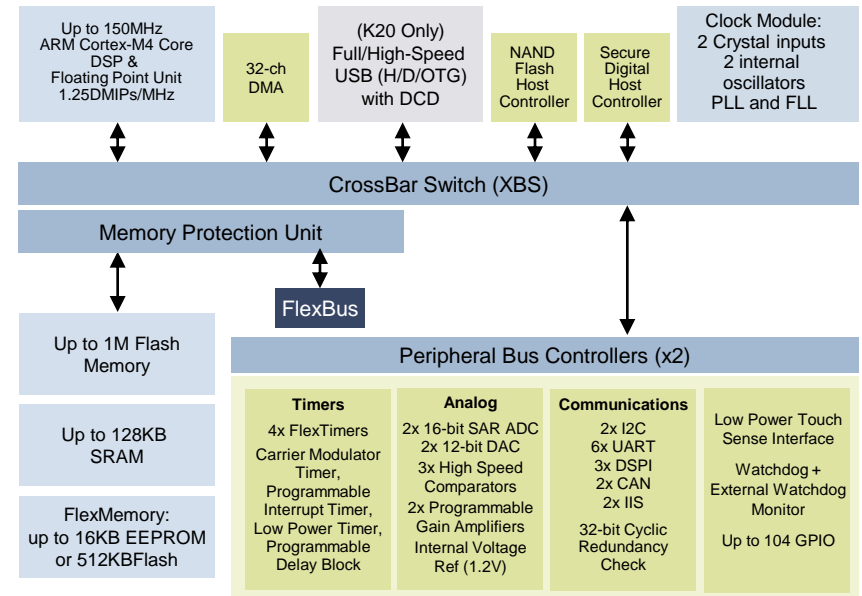

### Enablement Bundle

TOWER development system  
Complementary MQX RTOS with USB Stack  
Eclipse-Based CodeWarrior 10.0 IDE  
Processor Expert Rapid Application Development Tool  
IAR, Keil and full ARM Ecosystem Support  
Motor Control and DSP Libraries

Family	USB OTG + DCD
K10	-
K20	X

# K30/K40 Family Block Diagram

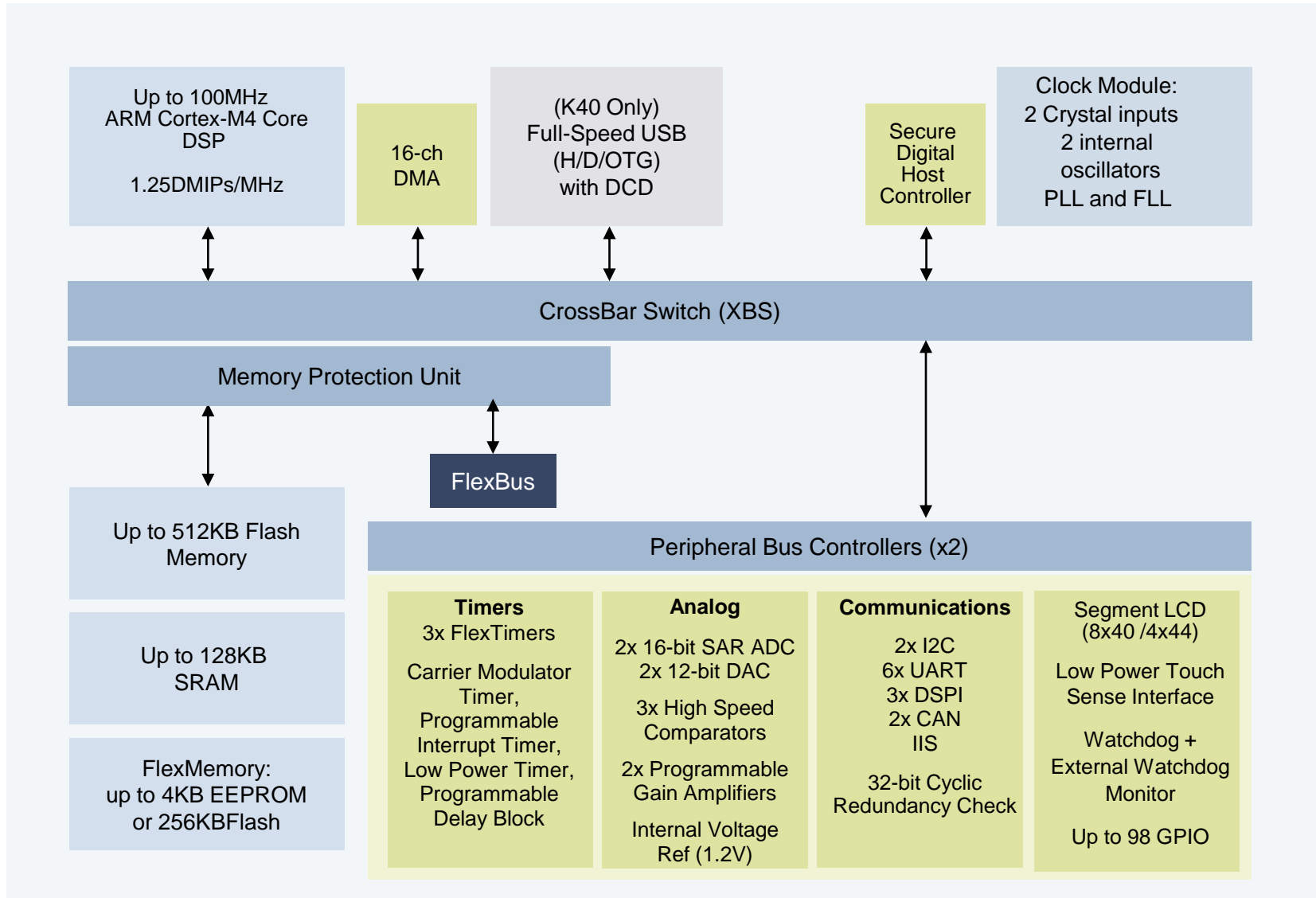



# K30/K40 Family Overview

## For Segment LCD HMI Applications

### ► Flexible, low power LCD Interface

- Segment LCD Blink mode lowers average power
- Segment Fail Detect prevents erroneous readouts and reduces LCD test cost
- Front/back plane reassignment provides pin-out flexibility and allows configuration changes in firmware

### ► Diverse communications suite

- A multitude of serial interfaces, with UART support for ISO7816 SIM/Smart Cards & IrDA interfaces
- Dual CAN for industrial network bridging

### ► System reliability & safety

- Hardware Cyclic Redundancy Check safeguards memory contents and communication data
- Memory Protection Unit – increase SW reliability
- Independently-clocked watchdog prevents code runaway for fail-safe applications e.g. IEC60730

### ► Hardware and software compatibility

- Common packages & peripherals across families enable rapid feature growth with minimal hardware & software disruption

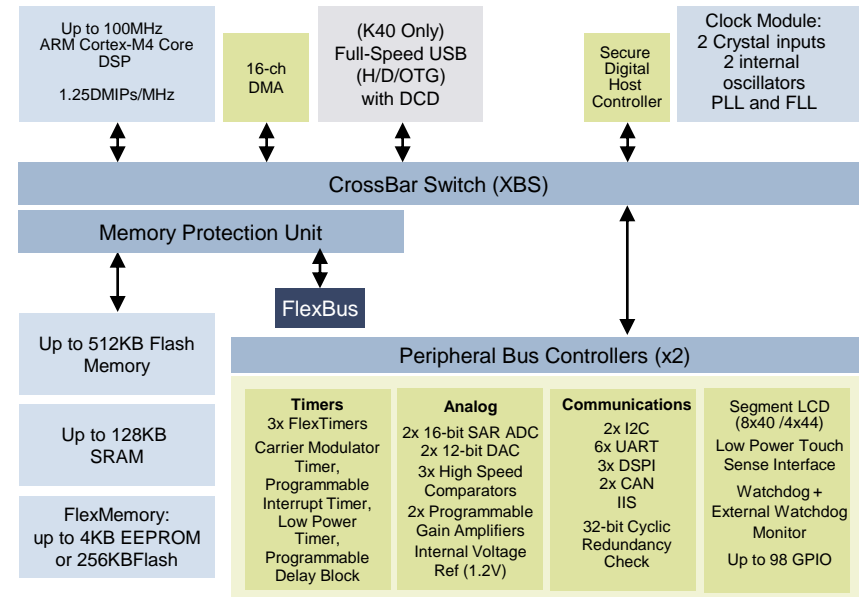

### Enablement Bundle

TOWER development system  
 Complementary MQX RTOS with USB Stack  
 Eclipse-Based CodeWarrior 10.0 IDE  
 Processor Expert Rapid Application Development Tool  
 IAR, Keil and Full ARM Ecosystem Support  
 Motor Control Software Library, IEC60730 test routines

Family	USB OTG + DCD	Segment LCD
K30	-	X
K40	X	X

# K60/K70 Family Block Diagram

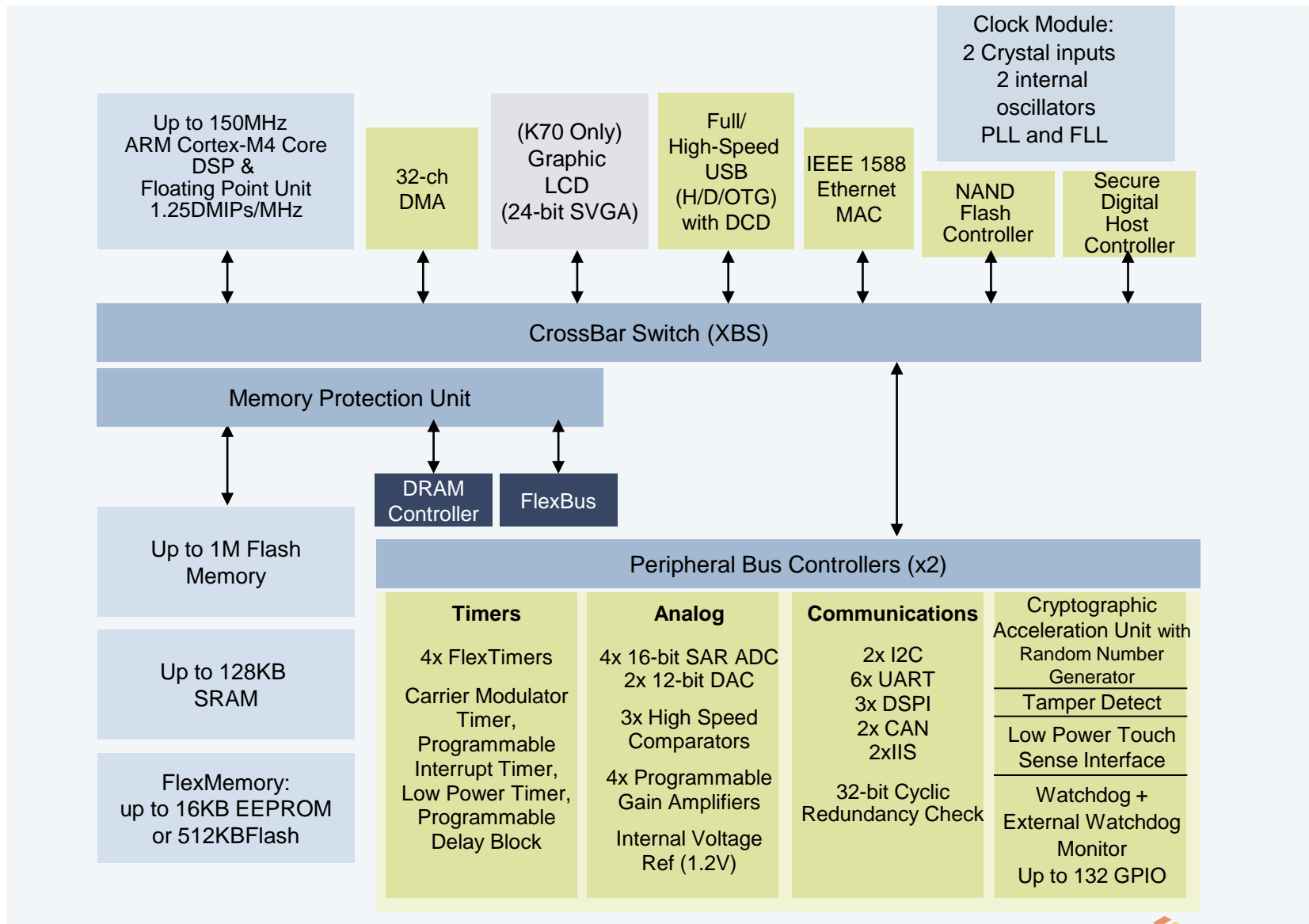

# K60/K70 Family Overview

## Higher Performance, Security, & Connectivity

### ► Real-time Ethernet for precision automation

- IEEE 1588 hardware time stamping & clock synchronization enables accurate, deterministic control over Ethernet networks

### ► (K70 only) Graphical LCD for advanced user interfaces

- Single-chip QVGA support possible, allowing use of lower-cost displays without Chip-on-Glass capability
- Up to 24-bit SVGA with external memory support

### ► Robust system security with tamper detection

- Tamper detection with voltage, frequency, and temperature monitoring. External sensor support for physical attack detection

### ► Hardware Encryption for secure data transfer & storage

- Significantly faster than software implementations while consuming minimal system resources.
- Supports numerous algorithms with hardware assisted software routines – SSH, SSL, IPSec, etc

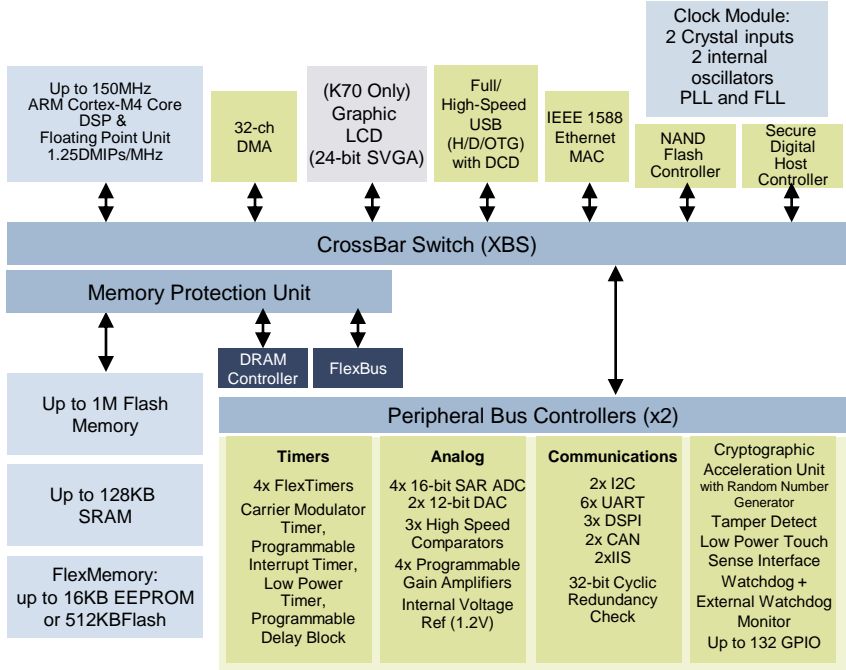

### Enablement Bundle

- TOWER development system
- Complementary MQX RTOS with TCP/IP & USB Stack
- Eclipse-Based CodeWarrior 10.0 IDE
- Processor Expert Rapid Application Development Tool
- IAR, Keil and Full ARM Ecosystem Support
- Graphics LCD and Encryption libraries

Family	Graphics LCD Controller	IEEE 1588 Ethernet / Encryption / Tamper Detect
K60	-	X
K70	X	X

Freescale, the Freescale logo, Altivec, C-5, CodeTEST, CodeWarrior, ColdFire, C-Ware, mobileGT, PowerQUICC, StarCore, and Symphony are trademarks of Freescale Semiconductor, Inc., Reg. U.S. Pat. & Tm. Off. BeeKit, BeeStack, CoreNet, the Energy Efficient Solutions logo, Flexis, MXC, Platform in a Package, Processor Expert, QorIQ, QUICC Engine, SMARTMOS, TurboLink and VortiQa are trademarks of Freescale Semiconductor, Inc. All other product or service names are the property of their respective owners. © 2010 Freescale Semiconductor, Inc.



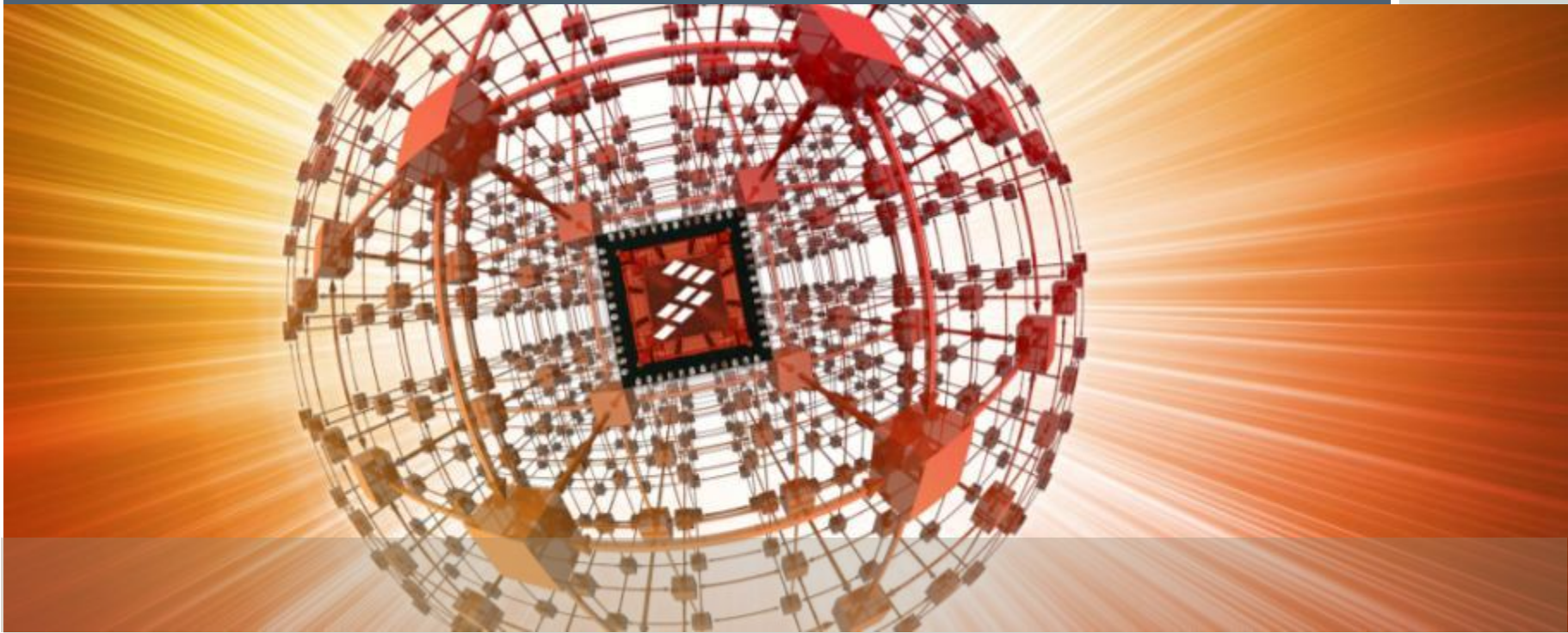

## Key Differentiators

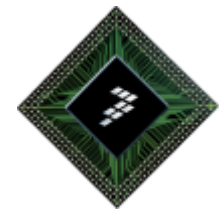

# What is FlexMemory?

## User Configurable As...

### EEPROM:

- ▶ **No external EEPROMs**
  - Reduced system cost
- ▶ **No system resource impact**
  - System performance maintained
  - No complex coding schemes
- ▶ **Configurable & high endurance**
  - Up to 10 Million w/e cycles
- ▶ **High performance**
  - Fast write time = 100 usec
  - Erase+write = 1.5msec
- ▶ **Use cases**
  - Critical data retention (power loss)
  - Frequently updated data

### Program or Data Flash:

- ▶ **Flexibility**
  - Space for future expansion needs
  - Contiguous with main program Flash
- ▶ **Efficient**
  - Read-while-write with the main program Flash
- ▶ **Use cases**
  - Program Flash: bootloader code space
  - Data Flash: large data tables

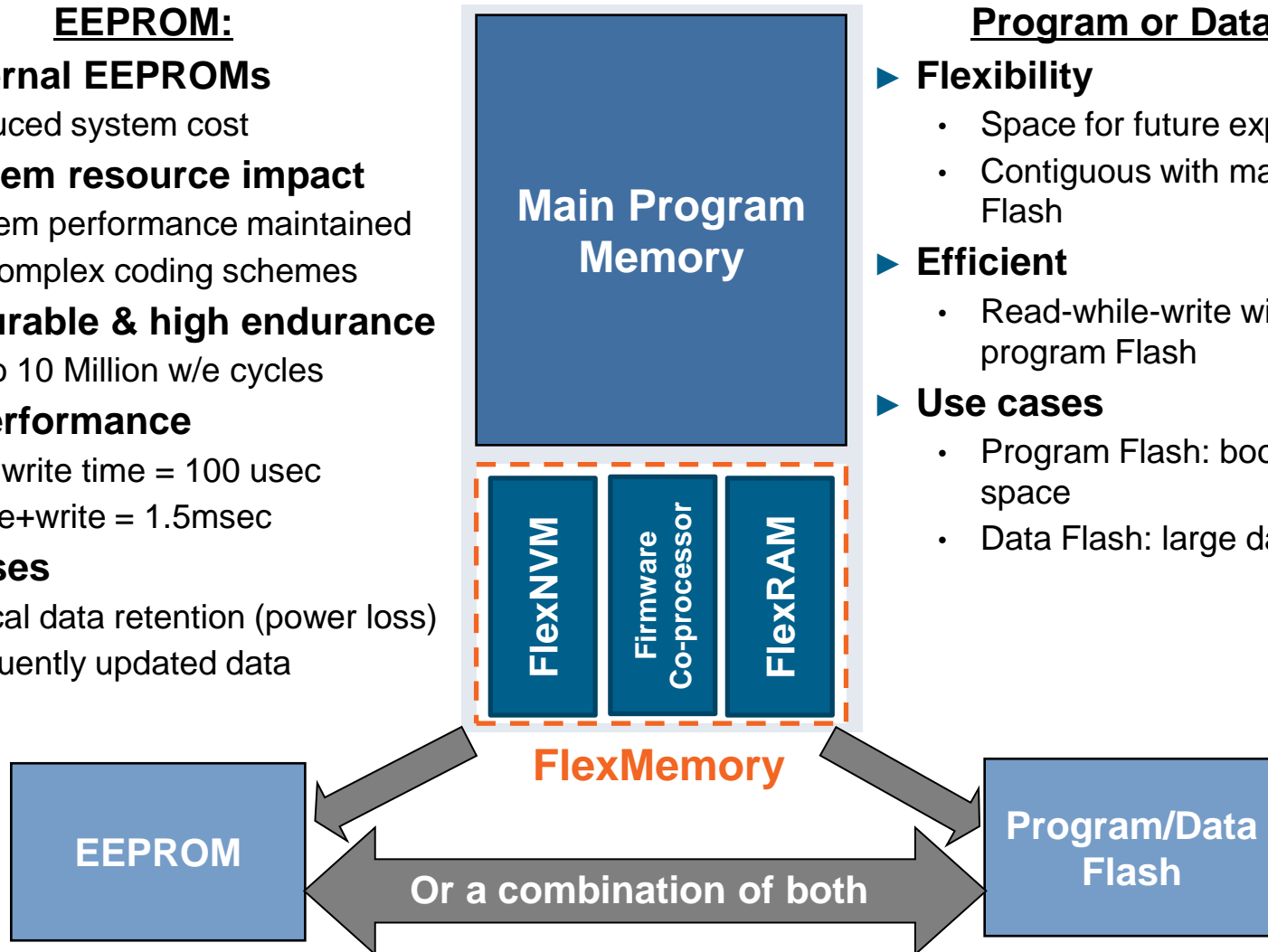



# Freescale FlexMemory vs. Traditional EEPROM

Attribute	Traditional Embedded EEPROM	FlexMemory
Read-while-write with program memory	Yes	Yes
Granularity	Byte write/erase	Byte write/erase
Write time	~1-5 msec (byte write only)	~100 $\mu$ sec (byte or word program to erased location, brown-outs w/o loss or corruption of data)
Erase + write time	~5-10 msec	~1.5 msec ( byte or word erase and program)
Endurance	50-300K cycles (fixed)	SoC implementation and user configurable, can exceed 10M cycles
Minimum write voltage	$\geq 2.0V$	1.71V
Flexibility	Fixed by part number	Programmable trade-off - quantity vs. endurance

## ➤ 16-bit SAR ADCs

- 1.15V minimum reference
- Differential or Single Ended
- Averaging by 1, 4, 8, 16, or 32
- Automatic Compare Function
- Triggering synchronization w/ DAC
- Configurable resolution, sample time, speed and power (8/10/12/16-bit resolution)
- Up to 20 input channels per converter

## ➤ Voltage Reference (Vref)

- Trimmable
- < 33ppm/°C temp variation

## ➤ 12-bit DACs

- 16 word DAC FIFO
- Hardware or software trigger

## ➤ High Speed Comparators

- Programmable hysteresis control, and interrupt trigger
- Selectable inversion on comparator output
- Integrated 6-bit DAC for reference

## ➤ Programmable Gain Amplifiers

- x64 gain

# Kinetis: Low Power Capabilities

## ➤ Flexible power modes

- **10** Run, Wait & STOP modes – customise power usage to application requirements



## ➤ Industry leading 90nm process technology

- **1/3** dynamic power reduction vs. existing technologies
- Intelligent power management controller reduces dynamic and leakage currents

## ➤ Low power design techniques

- Clock gating: only leakage currents are incurred
- Power gating: shuts down un-used modules reducing leakage

## ➤ Ultra fast wake up times

- **4μs** wake up from low leakage stop mode
- New Low Leakage Wake-up Unit for leakage current reduction

# Kinetis Power Modes

Typical Power Modes in an embedded system	Cortex M4 Power Modes	Kinetis Extended Power Modes	Recovery Time	"Typical" Idd Range
Run	Run	Run	-	Starting @ <200uA/MHz
Wait	Sleep	VLPR	-	Starting @ <200uA/MHz
Stop	DeepSleep	Wait	-	
		VLPW	4us	
		Stop	4us	
		VLPS	4us	
<b>Freescal Adds Low Leakage Wake-up Unit</b> <ul style="list-style-type: none"> <li>▶ Enables complete shut-down of core logic, including WIC, further reducing leakage currents in all low power modes</li> <li>▶ Supports 16 external input pins and 8 internal modules as wakeup sources</li> <li>▶ Wakeup inputs are activated in LLS or VLLS modes</li> </ul>		LLS	4us	1.2uA - 7uA
		VLLS3	35us	1uA - 5uA
		VLLS2	35us	750nA - 2uA
		VLLS1	100us+EE restore	500nA – 1.5uA

# ARM Cortex-M4 Processor Microarchitecture

## ▶ Backwards compatible with ARM Cortex-M3

## ▶ New features

- Single cycle MAC (Up to 32 x 32, with 32-bit result)
- DSP extensions
- Single Precision Floating Point Unit

## ▶ Freescale IP and Innovation

- On-chip cache for instructions and data
- Cross-Bar Switch for concurrent multi-master/slave accessing
- On-chip DMA for CPU off-load
- Low-leakage Wake-up Unit adds flexibility for low power operation

## ▶ Architected for Digital Signal Processing

- **Motor Control** - advanced algorithms, longer lifespan, power efficiency
- **Automation** - high calculation and algorithm bandwidth at a low cost
- **Power management** – designed for low/battery powered systems
- **Audio and Video** – 5x performance improvement over software, making batteries last longer

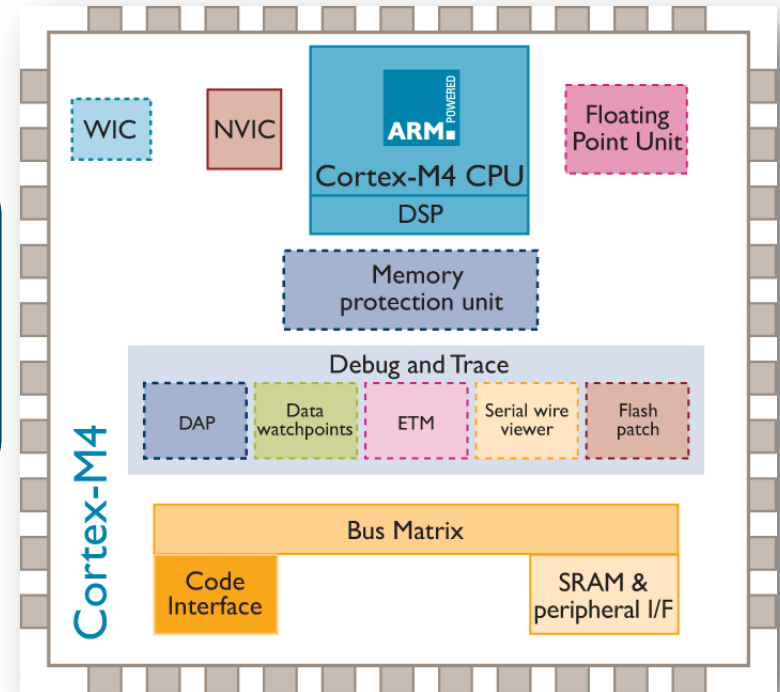



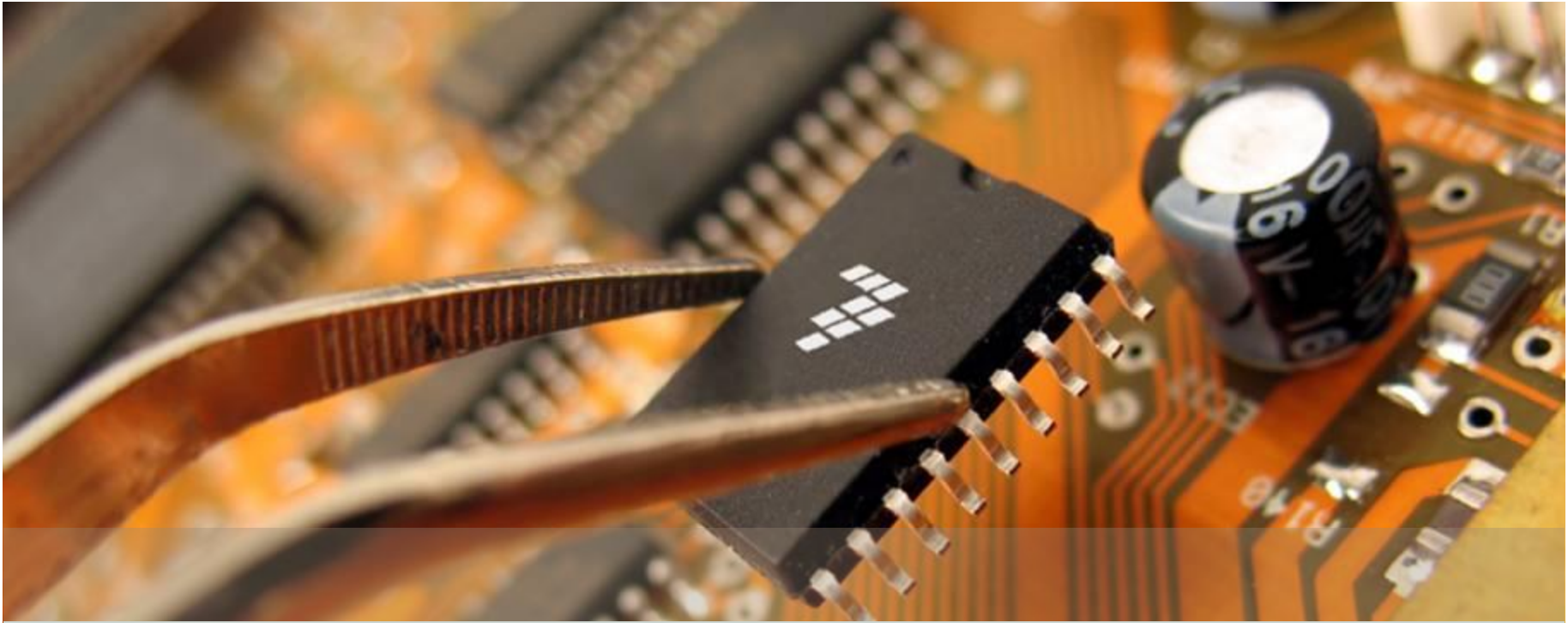

## Enablement: Software and Hardware Tools

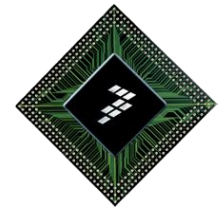

# Freescale's Microcontroller Enablement Bundle

## Freescale MQX + MCU

Complimentary MQX RTOS

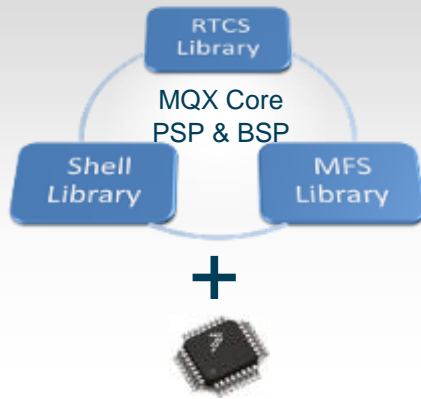

- Full-featured, scalable, proven RTOS
- Simplifies HW management, streamlines SW development
- Reduces development costs while speeding time to market

Comprehensive solution for embedded control and connectivity

## + Tower System



- Modular, expandable and cost-effective development platform for 8/16/32-bit MCUs and MPUs
- Rapid eval and prototyping with maximum HW reuse.
- Supported by a diverse range of MCU and peripheral plug-in boards and a growing web community

Open source hardware platform for prototyping application development

## + CodeWarrior IDE



- Eclipse environment
- Processor Expert code generation wizard
- Build, debug and flash tools
- Software analysis
- Kernel-aware debug
- Host platform support

Visual and automated framework to accelerate development time

Save time, cost, and effort.

# Freescale MQX RTOS Solution

## ► Scalable, fully-featured and proven RTOS bundled with 32-bit MCUs

### • Full-featured and powerful

- BSPs incorporate tightly integrated RTOS, Middleware (USB, TCP/IP stacks), file system, and I/O drivers
- Designed for speed and size efficiency

### • Market proven

- MQX has been available on Freescale processors for > 15 years
- MQX has been used in millions of products including Medical and Heavy Industrial areas

### • Simple and scalable

- Can be as small as ~10KB for smallest implementation, or scale up to support sophisticated networking and threading
- Intuitive API & modular architecture enables straight-forward feature fine-tuning
- Production source code provided

### • Similar to other “pay-for” software OS



MQX Software speeds time to market with support from Freescale

## Software Integration headache



## Integrated MQX Solution

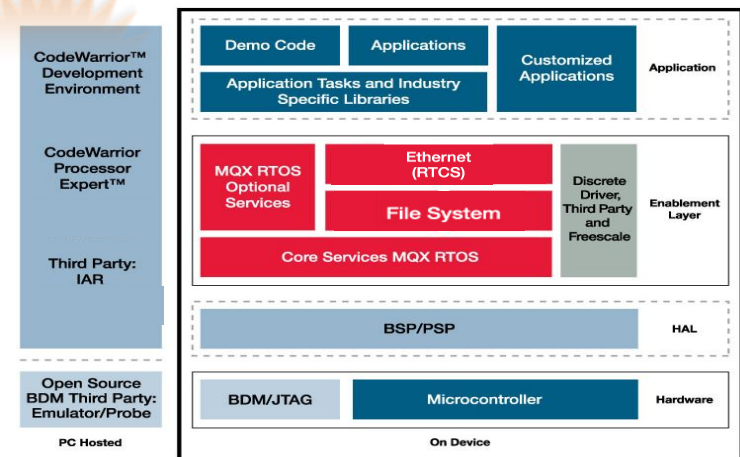

# The Freescale Tower System

## ► A modular development platform for 8/16/32-bit MCUs & MPUs

- Quickly combine Tower Modules to build a prototype of your application
- Modules sold individually or in kits
- Open Source: Build your own Tower Module to integrate your IP
- Cost-optimized hardware
- Software support from Freescale and Third Parties
- Growing community of Third Party hardware support
- On-line community: [www.towergeeks.org](http://www.towergeeks.org)

Rapidly build a prototype of your end application

Support for all ColdFire+ and Kinetis MCUs!

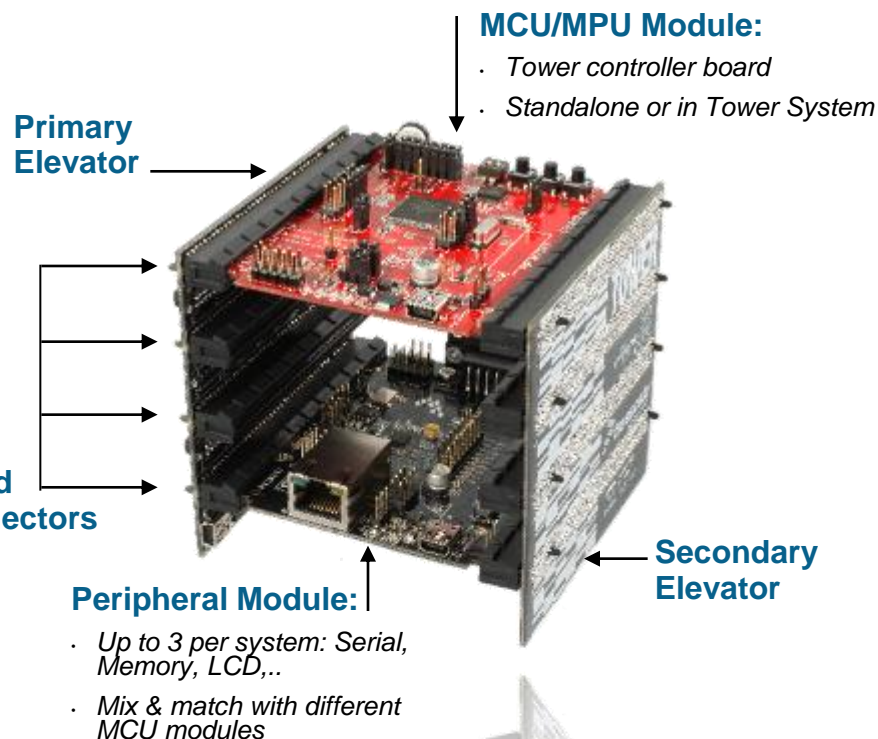

TWR-MEM



TWR-LCD



TWR-SENSOR-PAK



# CodeWarrior Development Studio for Microcontrollers v10.1

## ► Integrated development tool suite for ColdFire, Kinetis and S08 architectures based on the Eclipse open development platform

- Project Wizard creates a new project in as few as 9 clicks
- MCU Change Wizard retargets a project to a new processor in as few as 6 clicks
- CodeWarrior optimizing C/C ++ compilers for ColdFire and Kinetis Microcontrollers included
- Extensions to Eclipse CDT to provide sophisticated features to troubleshoot and repair embedded applications
- Processor Expert combines easy-to-use component-based application creation with an expert knowledge system
- Trace and profile support for on-chip trace buffers to provide emulator-like debug capability without additional hardware
- Kernel-aware debug for MQX, Linux and OSEK
- CodeWarrior Special Edition is a complimentary version up to 128KB code size

Accelerate the development of the most complex embedded applications



Free Compiler up to 128KB!

[www.freescale.com/codewarrior](http://www.freescale.com/codewarrior)  
to download



# IAR Embedded Workbench

- ▶ The most widely used tool chain for ARM MCUs
- ▶ A consistent tool chain for ColdFire+ and Kinetis devices
- ▶ Completely integrated development environment
- ▶ Highly optimized IAR C/C++ Compiler
- ▶ Powerful IAR C-SPY Debugger
- ▶ MQX integration
- ▶ Ready-made example projects



*More on [www.iar.com/freescale](http://www.iar.com/freescale)*

# Keil Software Development Tools

## Microcontroller Development Kit



Complete software development environment for Cortex-M and ARM7/9 microcontrollers

Easy to learn and use, yet powerful enough for the most demanding embedded ARM application

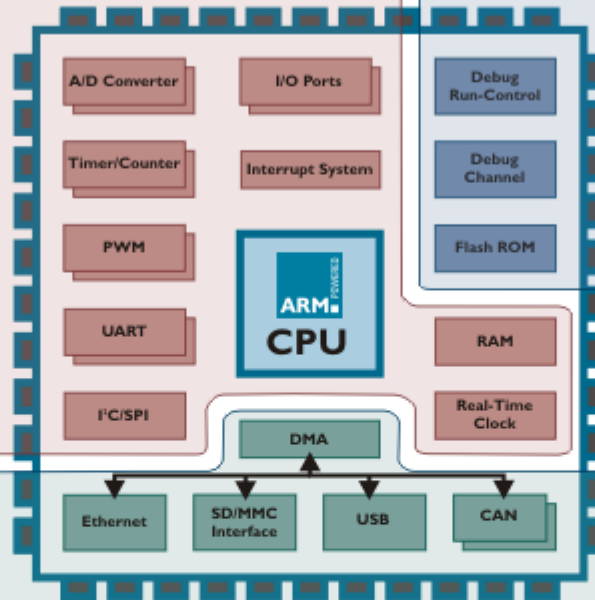
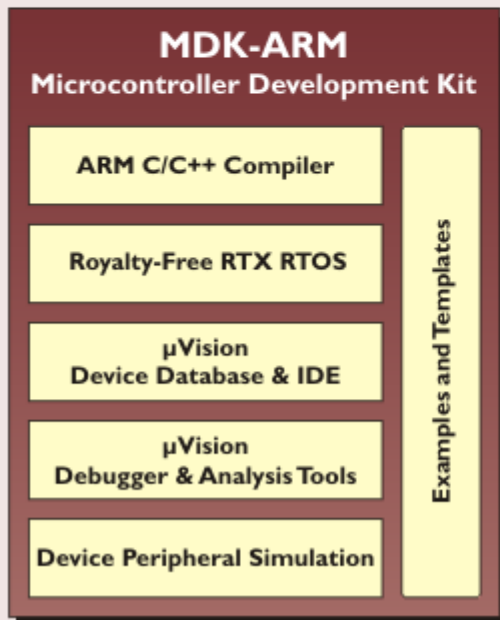

## RTOS and Real-Time Library

Fully featured real-time kernel

Library of middleware components to speed up software development and solve real-time and communication challenges

## ULINK USB Adapters

On-the-fly debugging and Flash programming via JTAG or serial interface

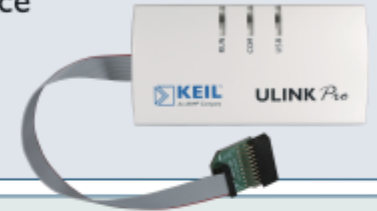

## RL-ARM Real-Time Library

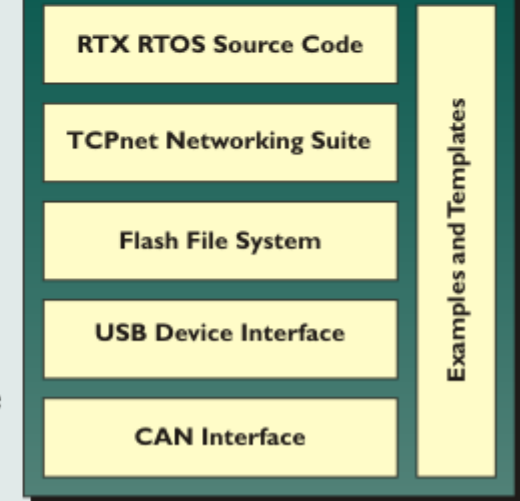

# Choose Your Partner: The Freescale Microcontroller Ecosystem

## Run-Time Software: RTOS, Stacks, File System



## HW BDM Debugger/Emulators



Rowley Associates



## IDE: Tools Compilers, Debuggers



GNU Tools



MQX Support /  
Design Services



Audio/Video  
Codecs

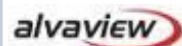

GUI  
Graphical



Security /  
Medical



EVBs &  
System Design



Ind. Protocol  
Stacks



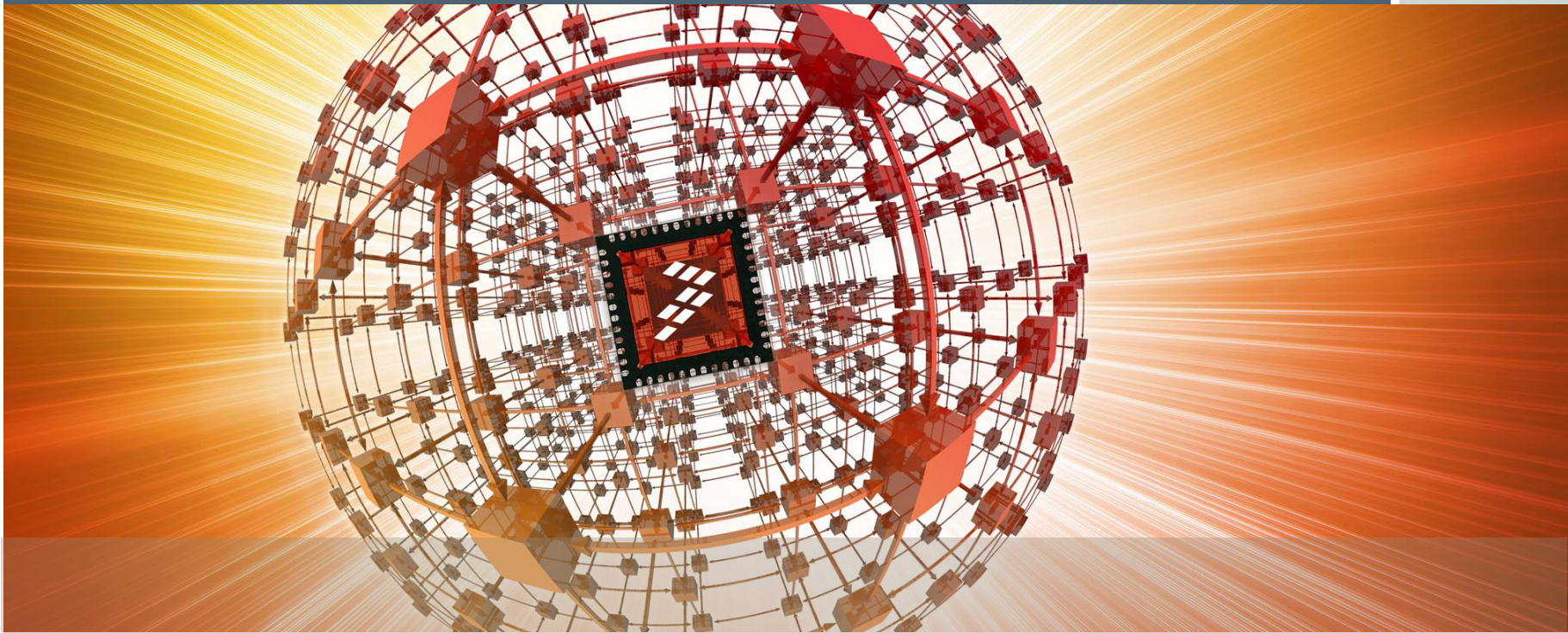

# Application Use Cases

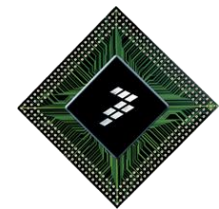



# Motor Control Use Case

**DSP hardware:**

▶ Accelerates motor control calculations

**DMA:**

▶ Off loads CPU from repetitive data transfers

**16-bit ADC & PGA:**

▶ Measures 3 phase bridge current and voltage

**Analog Comparator:**

▶ Detects back EMF  
▶ Monitors over current

**Programmable delay block:**

▶ Schedules delayed ADC conversions relative to Timer triggers

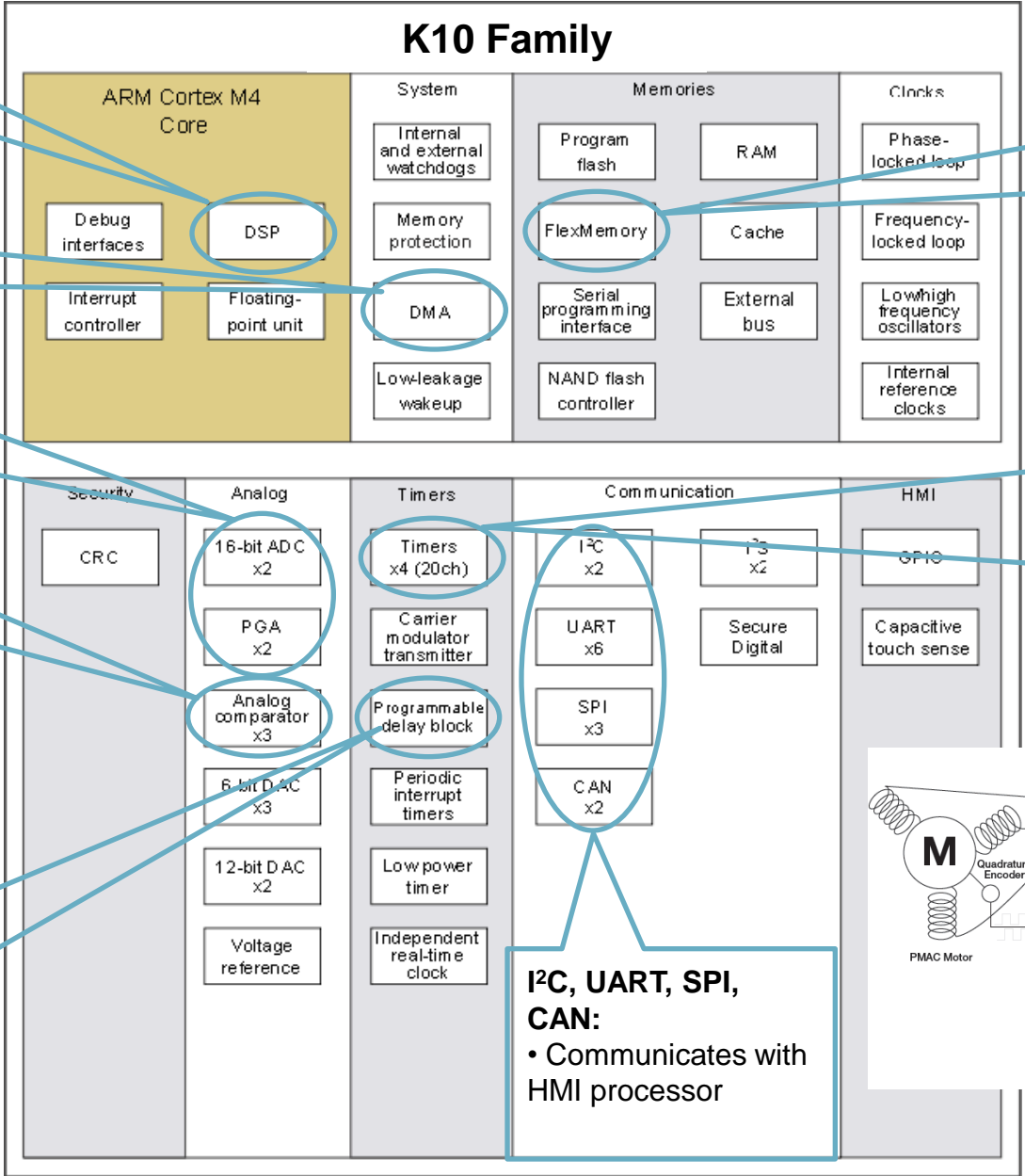

**FlexMemory:**

▶ Saving motor calibration data  
• Remote update bootloader

**Timers:**

▶ Drives various motor types including stepper, BLDC, and PMAC motors with sensor or sensorless algorithms  
▶ Built-in quadrature decoder detects motor speed

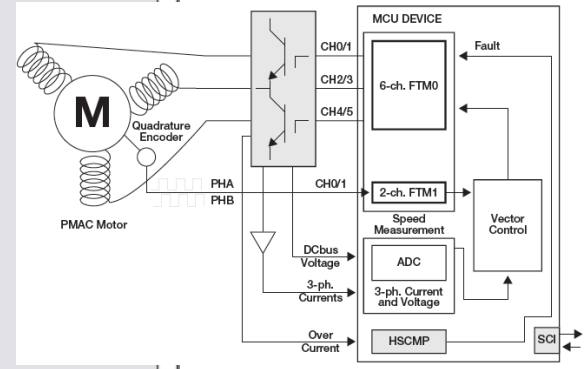



# Thermostat Use Case

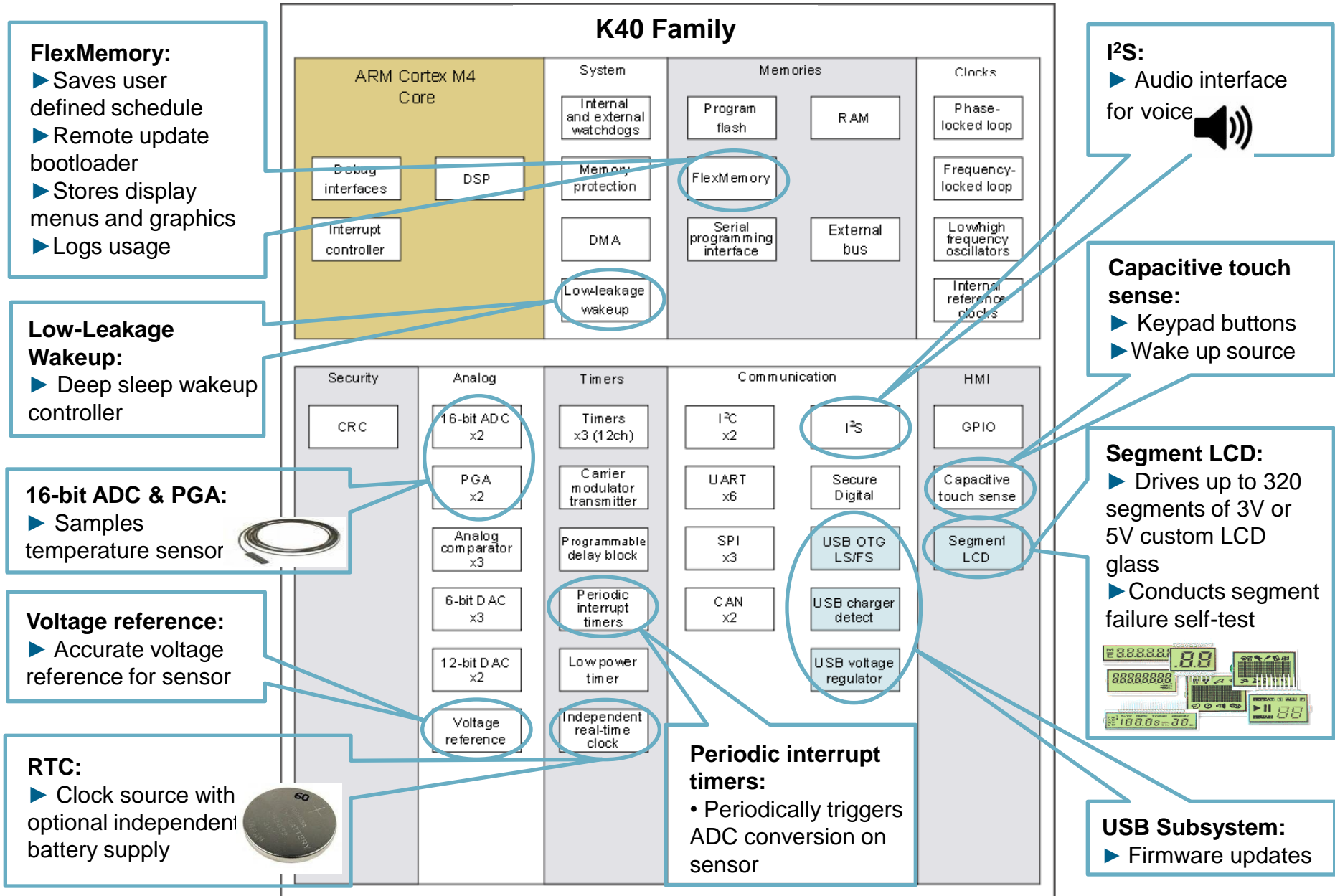

# Factory Automation Use Case

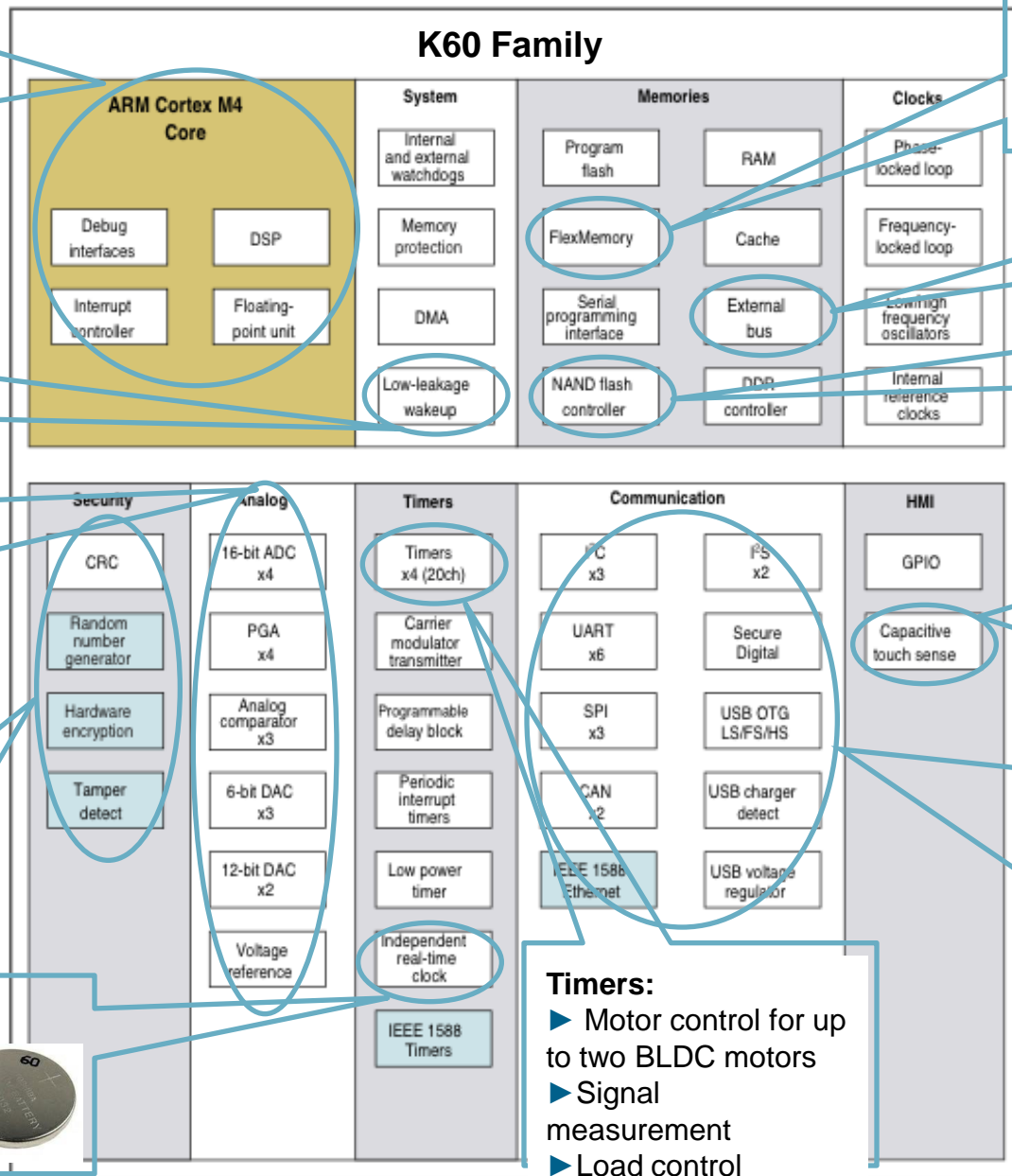

## Cortex-M4 core with DSP and FPU:

- ▶ Signal filtering
- ▶ Motor control
- ▶ Complex real time control algorithms

## Low-Leakage Wakeup:

- ▶ Deep sleep wakeup controller

## Mixed Signal:

- ▶ Sensor monitoring
- ▶ Load control
- ▶ Voltage and current measurement

## System security:

- ▶ IP protection
- ▶ Communication protection
- ▶ Tamper protection

## RTC:

- ▶ Clock source with optional independent battery supply



## FlexMemory:

- ▶ Equipment configuration & calibration
- ▶ Remote update bootloader

## External Bus:

- ▶ FPGA for custom logic

## NAND flash controller:

- ▶ External storage for data logging

## Capacitive touch sense:

- ▶ Robust keypad
- ▶ Robust slider input

## Comprehensive Industrial Connectivity:

- ▶ 10/100 Ethernet with 1588
- ▶ UARTs with RS485 and CAN for legacy protocols
- ▶ USB otg
- ▶ SPI and I2C for peripheral systems
- ▶ SDIO for wireless adaptors

## Timers:

- ▶ Motor control for up to two BLDC motors
- ▶ Signal measurement
- ▶ Load control

# Universal Remote Control Use Case

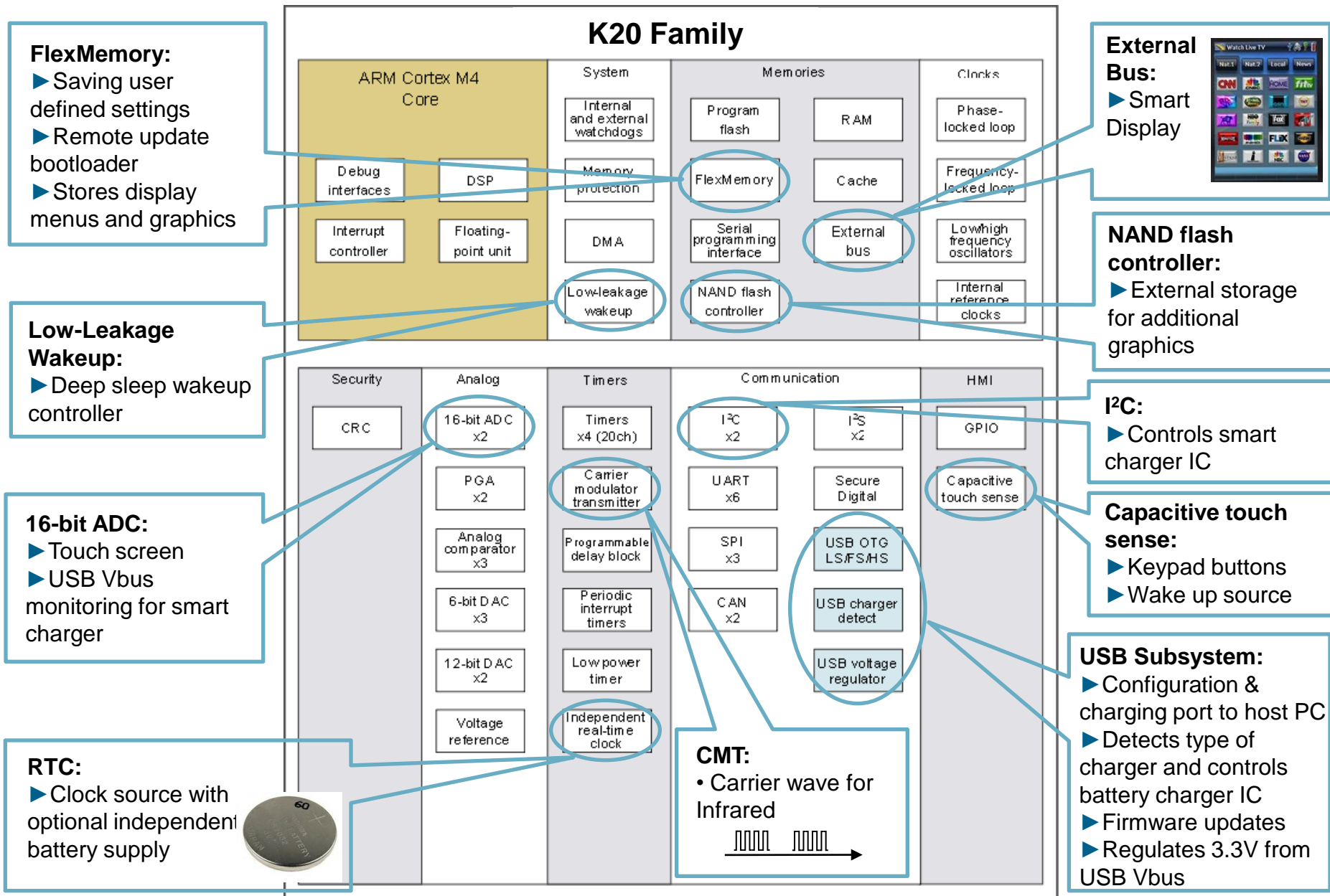

## FlexMemory:

- ▶ Saving user defined settings
- ▶ Remote update bootloader
- ▶ Stores display menus and graphics

## Low-Leakage Wakeup:

- ▶ Deep sleep wakeup controller

## 16-bit ADC:

- ▶ Touch screen
- ▶ USB Vbus monitoring for smart charger

## RTC:

- ▶ Clock source with optional independent battery supply



## External Bus:

- ▶ Smart Display



## NAND flash controller:

- ▶ External storage for additional graphics

## I2C:

- ▶ Controls smart charger IC

## Capacitive touch sense:

- ▶ Keypad buttons
- ▶ Wake up source

## USB Subsystem:

- ▶ Configuration & charging port to host PC
- ▶ Detects type of charger and controls battery charger IC
- ▶ Firmware updates
- ▶ Regulates 3.3V from USB Vbus

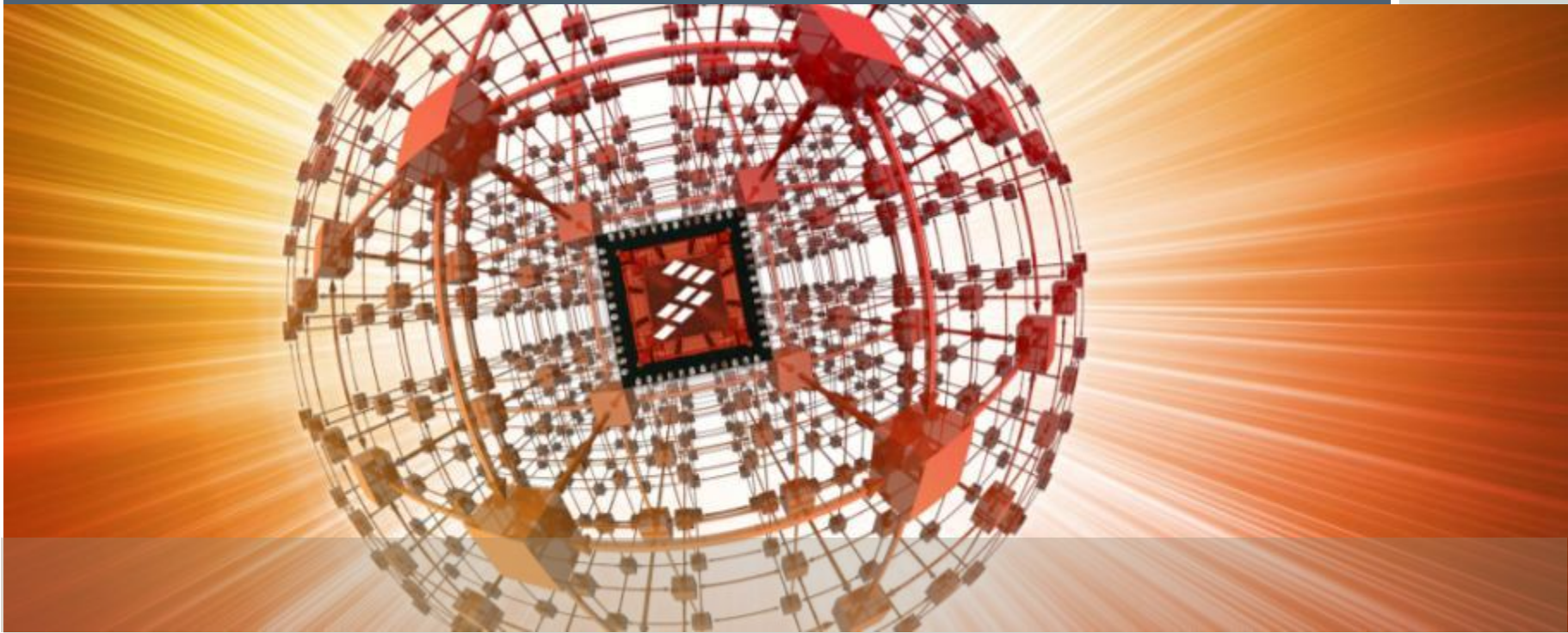

# Technical Overview

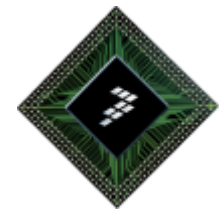

# Pin Compatibility Across Families

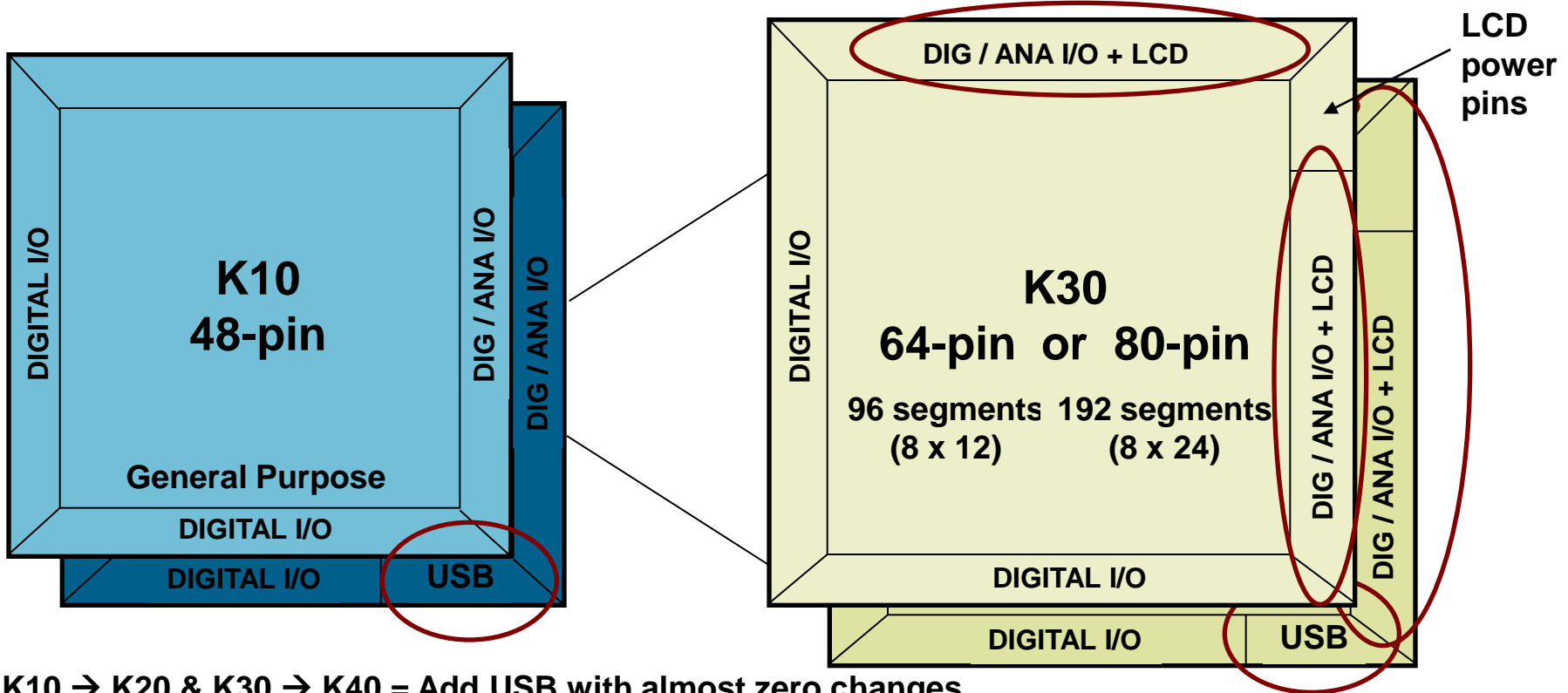

**K10 → K20 & K30 → K40 = Add USB with almost zero changes**

- ✓ The only difference will be 4 extra USB pins and 4 less digital I/O pins

**K10 → K30 & K20 → K40 = Add Segment LCD with minimal board layout changes**

- ✓ Digital & Analog I/O signals maintain placement order
- ✓ Segment LCD signals are muxed with existing Digital & Analog I/O signals
- ✓ Most Digital I/O signals muxed with Segment LCD signals become available on added pins by larger package

**K20 → K60 = Add Ethernet with NO changes**

- ✓ All Ethernet signals are muxed with existing Digital & Analog I/O signals

**DIGITAL I/O = UART, SPI, I2C, CAN, TIMER, etc.**

**ANALOG I/O = OSC, ADC, CMP, etc.**



# Operating Parameters

Operating Parameters	
<b>Voltage Range (VDD)</b>	1.71 to 3.6 V
	Flash programming across entire voltage range
<b>Temperature Range (TA)</b>	-40 to 105°C
<b>Maximum CPU Frequency Tiers (Max. CPUCLK)</b>	50 MHz
	72 MHz
	100 MHz
	120 MHz
	150 MHz



# Package Options

Type	Body Size	Pitch	Families
32-pin QFN	5 x 5 mm	0.5 mm	K10, K20
48-pin QFN	7 x 7 mm	0.5 mm	K10, K20
48-pin LQFP	7 x 7 mm	0.5 mm	K10, K20
64-pin QFN	9 x 9 mm	0.5 mm	K10, K20, K30, K40
64-pin LQFP	10 x 10 mm	0.5 mm	K10, K20, K30, K40
80-pin LQFP	12 x 12 mm	0.5 mm	K10, K20, K30, K40
81-pin MAPBGA	8 x 8 mm	0.65 mm	K10, K20, K30, K40
100-pin LQFP	14 x 14 mm	0.5 mm	K10, K20, K30, K40, K60
104-pin MAPBGA	8 x 8 mm	0.65 mm	K10, K20, K30, K40, K60
144-pin LQFP	20 x 20 mm	0.5 mm	K10, K20, K30, K40, K60
144-pin MAPBGA	13 x 13 mm	1.0 mm	K10, K20, K30, K40, K60
196-pin MAPBGA	15 x 15 mm	1.0 mm	K60
256-pin MAPBGA	17 x 17 mm	1.0 mm	K60

- ▶ QFN/LQFP packages optimized for cost reduced 2 layer board designs
- ▶ MAPBGA packages optimized for cost reduced 4 layer board designs

## Freescale Confidential and Proprietary

Freescale, the Freescale logo, CodeWarrior, ColdFire and Powerquicc are trademarks of Freescale Semiconductor, Inc., Reg. U.S. Pat. & Tm. Off. Flexis, Processor Expert and QorIQ are trademarks of Freescale Semiconductor, Inc. All other product or service names are the property of their respective owners. The Power Architecture and Power.org word marks and the Power and Power.org logos and related marks are trademarks and service marks licensed by Power.org. ARM is the registered trademark of ARM Limited. ARM Cortex-M4 and ARM Cortex-M3 are trademarks of ARM Limited. © 2010 Freescale Semiconductor, Inc.

# Embedded Memory Options

- ▶ Multiple flash arrays allowing code execution while non-volatile data or firmware are updated
- ▶ Robust update option for seamlessly switching program code execution between flash arrays
- ▶ FlexMemory option from 32 KB to 512 KB FlexNVM for additional program and data flash
  - Common uses:
    - Large data tables
    - Protected bootloader
- ▶ FlexMemory option for high-endurance, byte-writeable, embedded EEPROM from 32 bytes to 16 KB with up to 10 million read/write cycles
  - Common uses:
    - Saving frequently updated data
    - Protecting critical data during brown out conditions

# Memory Map Examples

## With FlexMemory

0x0000_0000	PFlash	256KB
0x0004_0000	Reserved	
0x1000_0000	FlexNVM	256KB
0x1004_0000	Reserved	
0x1400_0000	FlexRAM	4KB
0x1400_1000	Reserved	
0x1FFF_0000	System RAM TCML	64KB
0x2000_0000	System RAM TCMU	64KB
0x2001_0000	Reserved	
0x2200_0000	TCMU Bitband Alias	2MB
0x2220_0000	Reserved	
0x4000_0000	AIPS0 Peripherals	512KB
0x4008_0000	AIPS1 Peripherals	508KB
0x400F_F000	GPIO Peripheral	4KB
0x4010_0000	Reserved	
0x4200_0000	Periph Bitband Alias	32MB
0x4400_0000	Reserved	
0x6000_0000	Flexbus	2GB
0xE000_0000	Private Peripheral	1MB
0xE010_0000	Reserved	
0xFFFF_FFFF	Reserved	

## Without FlexMemory

0x0000_0000	PFlash	512KB
0x0008_0000	Reserved	
0x1400_0000	FlexRAM	4KB
0x1400_1000	Reserved	
0x1FFF_0000	System RAM TCML	64KB
0x2000_0000	System RAM TCMU	64KB
0x2001_0000	Reserved	
0x2200_0000	TCMU Bitband Alias	2MB
0x2220_0000	Reserved	
0x4000_0000	AIPS0 Peripherals	512KB
0x4008_0000	AIPS1 Peripherals	508KB
0x400F_F000	GPIO Peripheral	4KB
0x4010_0000	Reserved	
0x4200_0000	Periph Bitband Alias	32MB
0x4400_0000	Reserved	
0x6000_0000	Flexbus	2GB
0xE000_0000	Private Peripheral	1MB
0xE010_0000	Reserved	
0xFFFF_FFFF	Reserved	

- ▶ Identical peripherals and memory maps simplifying code reuse
- ▶ Transparent migration between devices with or without FlexMemory to quickly add additional program flash, data flash or EEPROM.

# Flash Security Options

Security State	Description
Unsecured	Debug Access: Full FSL Factory Access: Full
Secured Level I	Debug Access: Mass Erase Only FSL Factory Access: ERSALL, RD1ALL, RDREG, WRREG, and the RAM-only commands
Secured Level II	Debug Access: Mass Erase Only FSL Factory Access: Mass Erase Only
Secured Level III	Debug Access: No Access FSL Factory Access: No Access

## Mechanisms for Changing Flash Security State

Mechanism	Description
Backdoor Key	Providing an 8-byte key that is compared with one stored in flash allow the SW to change the security state. Usually the key is provided through an external port.
Debug Access	Through the debug port a Flash mass erase can be performed, clearing the security state.
FSL Factory Access	In secured Level I, NVMBIST mode can only perform a Mass Erase. Other test modes have full access to change all flags, and the entire contents of the NVM memory.

# System RAM Memory Map

Tightly Coupled Memory Lower (TCML) SRAM	0x1800_0000–0x1FFF_FFFF
Tightly Coupled Memory Upper (TCMU) SRAM	0x2000_0000–0x200F_FFFF

- SRAM performance for core accesses:
  - Instruction fetch from TCML has zero wait states
  - Instruction fetch from TCMU has one wait state
  - Data fetch from TCML and TCMU have zero wait states
- The on-chip SRAM is implemented with TCML:TCMU ranges forming a contiguous block of memory. TCML is anchored to 0x1FFF\_FFFF and occupies the range before this base address. The TCMU is anchored to 0x2000\_0000 and occupies the space after this base address.
- SRAM retained in VLLS2 mode starts at TCMU 0x2000\_0000

# Debug and Trace Options

## Debug Interfaces

2-pin Serial Wire Debug (SWD)

4 or 5-pin IEEE 1149.1 Joint Test Access Group (JTAG)

2-pin IEEE 1149.7 Compact JTAG (cJTAG)

- ▶ Use advanced debug & trace features in larger footprint with ETM and ETB and cost reduce in smaller package options

## Debug & Trace Resources

Trace Port Interface Unit (TPIU)

Flash Patch and Breakpoint (FPB)

Data Watchpoint and Trace (DWT)

Instrumentation Trace Macrocell (ITM)

Embedded Trace Macrocell (ETM)

Embedded Trace Buffer (ETB)



# EzPort (EZP) Features

- ▶ Serial interface that is compatible with a subset of the SPI format.
- ▶ Able to read, erase and program flash memory
  - Supports section program command for most efficient programming
- ▶ Able to reset the micro-controller, allowing it to boot from the flash memory after the memory has been configured
- ▶ EzPort can be made available on the JTAG header (10-pin or 20-pin)
  - EzPort can program the flash faster than JTAG
  - Using EzPort on JTAG header allows for fast programming option without needing an additional header
  - Will be supported by CodeWarrior tool chain
- ▶ EzPort force disable option bit in flash option register
  - User programmable bit that can disable entry into EzPort mode
    - Prevents accidental entry into EzPort mode
    - Extra system security (prevents EzPort from being used as a security exploit)

## Freescale Confidential and Proprietary

Freescale, the Freescale logo, CodeWarrior, ColdFire and Powerquicc are trademarks of Freescale Semiconductor, Inc., Reg. U.S. Pat. & Tm. Off. Flexis, Processor Expert and QorIQ are trademarks of Freescale Semiconductor, Inc. All other product or service names are the property of their respective owners. The Power Architecture and Power.org word marks and the Power and Power.org logos and related marks are trademarks and service marks licensed by Power.org. ARM is the registered trademark of ARM Limited. ARM Cortex-M4 and ARM Cortex-M3 are trademarks of ARM Limited. © 2010 Freescale Semiconductor, Inc.

# Cross Bar Switch (XBS) Features

- ▶ **Symmetric crossbar bus switch implementation**
- ▶ **Allows concurrent, non-blocking accesses from different masters to different slaves**
  - Allowing multiple masters to run bus cycles concurrently increases available system bus bandwidth
- ▶ **Up to 8 master ports and 8 slave ports, scalable through parameters and wrapper**
- ▶ **32-bit wide and supports byte, word (2 byte), longword (4 byte), and 16 byte burst transfers**
- ▶ **Operates at a 1-to-1 clock frequency with the bus masters**
- ▶ **Slave arbitration attributes configured on a slave by slave basis**
- ▶ **Low-power park mode support**

# Cross Bar Switch (XBS) Example

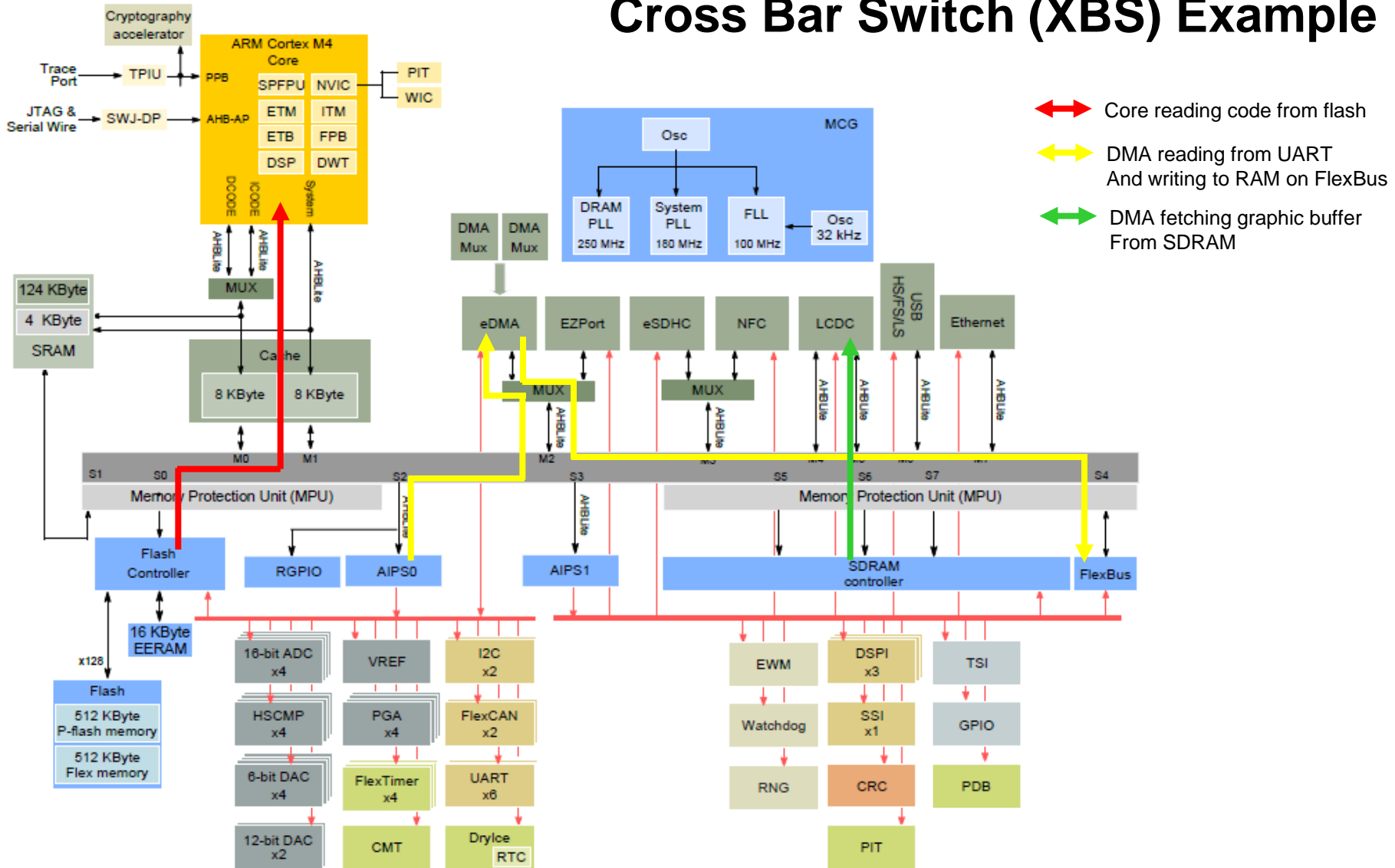

## 16 or 32 channel implementation that performs complex data transfers with minimal CPU intervention

- Number of channels depends on the specific Kinetis device
- Connections to the crossbar switch for bus mastering the data movement

## Programmable source and destination addresses and transfer size

- All data movement via dual-address transfers: read from source, write to destination
- Internal data buffer used a temporary storage to support 16-byte burst transfers
- Support for enhanced addressing modes
  - Support for scatter/gather DMA processing
  - Support for complex data structures
- Supports 8-bit, 16-bit, 32-bit, and 16-byte transfer sizes

## Transfer control descriptor (TCD) organized to support two-deep, nested transfer operations

- 32-byte TCD stored in local memory for each channel
- An inner data transfer loop defined by a minor byte transfer count
- An outer data transfer loop defined by a major iteration count

## Channel activation via one of three methods:

- Explicit software initiation
- Initiation via a channel-to-channel linking mechanism for continuous transfers
- Peripheral-paced hardware requests (one per channel)
- Support for cancelling transfers via hardware or software

## Fixed-priority and round-robin channel arbitration

## Channel completion reported via optional interrupt requests

- One interrupt per channel, optionally asserted at completion of major iteration count
- Optional error terminations per channel and logically summed together to form
- One error interrupt to the interrupt controller

# FSL MPU vs. ARM MPU

Feature	FSL MPU	ARM MPU
Region Descriptors	Up to 16	Up to 8; each with 8 equal sub-regions
Region Sizes	32 byte to 4 GB; allows overlapping protection	32 byte to 4 GB; allows overlapping protection
Access Control Rights	<p><b>Up to 8 AHB Master Connections:</b></p> <ul style="list-style-type: none"> <li>• Core Masters: read, write, and execute attributes for supervisor and user accesses</li> <li>• Non-core Masters: read and write attributes</li> </ul>	<p><b>Core Only:</b></p> <ul style="list-style-type: none"> <li>• Read, write, and execute attributes for supervisor and user accesses</li> </ul>
Protected Resources	<ul style="list-style-type: none"> <li>• TCMU SRAM</li> <li>• TCML SRAM</li> <li>• SRAM via crossbar switch               <ul style="list-style-type: none"> <li>• Flash</li> <li>• FlexBus</li> </ul> </li> <li>• DRAM Controller (3 ports)</li> <li>• IPS is protected by AIPS Controller</li> </ul>	<ul style="list-style-type: none"> <li>• TCMU SRAM</li> <li>• SRAM via crossbar switch               <ul style="list-style-type: none"> <li>• FlexBus</li> </ul> </li> <li>• DRAM Controller (3 ports)</li> <li>• IPS</li> </ul>
Error Reporting Mechanism	<ul style="list-style-type: none"> <li>• Generates access protection error</li> </ul> <p>Multiple error registers (one per slave port) capture the last faulting address, master number, attributes, etc.</p>	<ul style="list-style-type: none"> <li>• Generates access protection error (MemManage Fault Handler)</li> </ul> <p>Single error registers capture the last faulting address, attributes, etc.</p>



- ▶ **Independent clock source input** (independent from CPU/Bus clock). Choice between two clock sources:
  - 1 KHz Internal Oscillator (external to the WDOG)
  - Bus clock
- ▶ **Unlock sequence** for allowing updates to write-once WDOG Control/Configuration bits.
- ▶ **All WDOG Control/Configuration bits are writeable once only, within 256 bus clock cycles of being unlocked.**
  - Users need to always update these after unlocking, within 256 bus clock cycles. Failure to update resets the system.
- ▶ **Programmable Timeout period**, specified in terms of number of WDOG clock cycles.
- ▶ **Ability to test WDOG timer and reset**, with flag indicating watchdog test. This test can be permanently disabled.
  - Quick Test – Small timeout value programmed for quick test.
  - Byte Test – Individual bytes of timer tested one at a time.

## ▶ Read only Access to WDOG timer

- Allows dynamic check that WDOG timer is operational

## ▶ Windowed Refresh Option

- Provides robust check that program flow is faster than expected.
- Programmable window.
- Refresh outside window leads to reset.

## ▶ Robust refresh mechanism

- Write values of 0xA602 and then 0xB480, within 20 bus clock cycles of each other, to WDOG Refresh Register.

## ▶ Count of WDOG resets as they occur.

- Configurable **interrupt on timeout** to provide "**debug breadcrumbs**". This is followed by a reset after 256 bus clock cycles.

## ▶ **Class B: IEC 60730 compliant** by providing system robustness, diagnostic and self test mechanisms to ensure safe operation of hardware and software in application

- ▶ **Independent clock source input** (independent from CPU/Bus clock). Choice between two clock sources:
  - 1 KHz Internal Oscillator (external to the WDOG)
- ▶ **Programmable Timeout period**, specified in terms of number of EWM clock cycles.
- ▶ **Windowed Refresh Option**
  - Provides robust check that program flow is faster than expected.
  - Programmable window.
  - Refresh outside window leads to EWM\_OUT\_b pin assertion
- ▶ **Robust refresh mechanism**
  - Write values of 0xB4 and 0x2C to EWM Refresh Register within 15 bus clock cycles of each other, to WDOG Refresh Register.
- ▶ **One output pin, EWM\_OUT\_b**, when asserted is used to reset or place the external circuit into safe mode.
- ▶ **One input pin, EWM\_IN**, allows an external circuit to control the EWM\_OUT\_b pin.

# High Level Clocking System

## ▶ Two oscillator options

- System
  - kHz & MHz range
  - Operates from System power domain
- RTC
  - kHz range
  - Can be system oscillator
  - Operates from RTC VBAT power domain

## ▶ “On-the-fly” clock dividers with individual clock gating

- Core/Platform Clock
- Peripheral Bus Clock
  - Can operate 1:1 ratio to Core/Platform Clock up to maximum 50 MHz
  - Clock to most peripherals
- FlexBus Clock
  - Maximum 50 MHz
- Flash Clock
  - Maximum 25 MHz
- USB Clock
  - Maximum 48 MHz
  - Fractional clock divider

## ▶ Low power boot option

- User non-volatile register bit forces all clock dividers to maximum allowable dividers on system reset or POR for reduced average boot current.

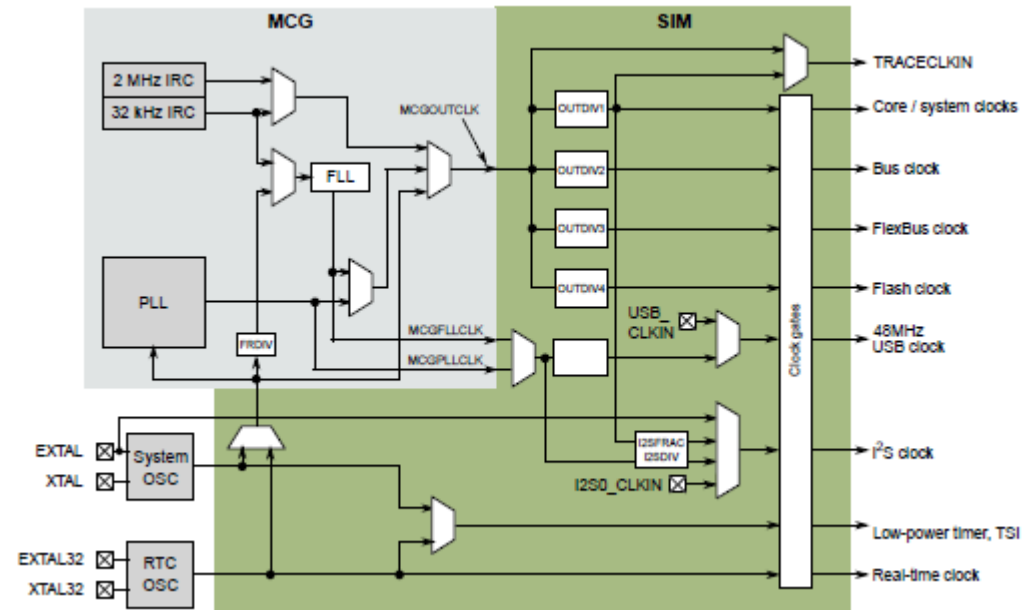

▶ 1:1 peripheral bus to core/platform clock ratio up to 50 MHz improves peripheral performance while reducing overall power consumption

▶ Clock gating allows an application unused peripheral clocks to further minimize current consumption

OSC Clock Sources	
<b>External crystal oscillator or resonator</b>	Low Range: 32 – 40 kHz
	Medium Range: 2 - 8 MHz
	High Range: 8 – 32 MHz
<b>External square wave input clock</b>	DC to 50 MHz

- ▶ **Multiple crystal oscillator frequencies supported for deriving accurate, low-jitter clocks**
- ▶ **Run IEEE 1588 Ethernet and USB simultaneously from 50 MHz clock output from external PHY eliminating need for additional system crystal**



# Oscillator Configurations

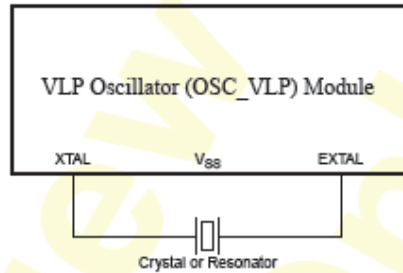

**Configuration for crystal/resonator:**  
• Low Frequency, Low Power

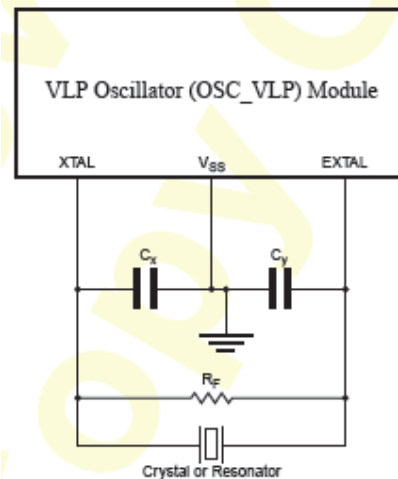

**Configuration for crystal/resonator:**  
• Low Frequency, High Gain  
• High Frequency, Low Power  
• High Frequency, High Gain

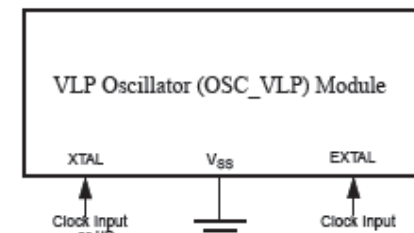

**Configuration for external clock**

- ▶ Flexible oscillator configuration eliminating external components for cost savings
- ▶ Options for low power operation and extending battery life operation

Internal Reference Clocks
32 kHz oscillator
2 MHz oscillator
1 kHz oscillator (LPO)

FLL DCO Ranges		
	Frequency Range (DMX32 = 0)	Max Frequency @ 32.768 kHz (DMX32 =1)
Range 0	20 – 25 MHz	24 MHz
Range 1	40 - 50 MHz	48 MHz
Range 2	60 - 75 MHz	72 MHz
Range 3	80 – 100 MHz	96 MHz

Max CPU Frequency Tiers	PLL VCO Ranges
50, 72, and 100 MHz	Up to 100 MHz
120 and 150 MHz	Up to 300 MHz

► Increased FLL DCO Ranges and Internal Reference Clock options for fine tuning performance with no external clock components

## ▶ 5V tolerant pins on some devices

- Use open drain connections to interface to other 5V devices

## ▶ Pin interrupt and DMA capability

- Rising/Falling edges and both edge and level
- Each 32 pin port can generate an interrupt or DMA request

## ▶ Digital glitch filter

- Spurious noise filter
- Configurable width and clock source

## ▶ Hysteresis and configurable pull up/pull down device on all input pins

## ▶ Configurable slew rate and drive strength on all output pins

- Reduced noise on output pins

# Hardware Touch-Sensing Interface (TSI)

## ▶ Capacitive touch sensing detection across all low power modes

- Automatic periodic scan with configurable duty cycle
- Low power mode current adder can be  $<1\mu\text{A}$

## ▶ 16 input capacitive touch sensing pins

- Each with individual result registers
- Automatic detection of Electrode Capacitance Change with programmable upper and lower threshold
- No need for external components

## ▶ TSI interrupts

- End of Scan, Out of Range, pad short or conversion overrun

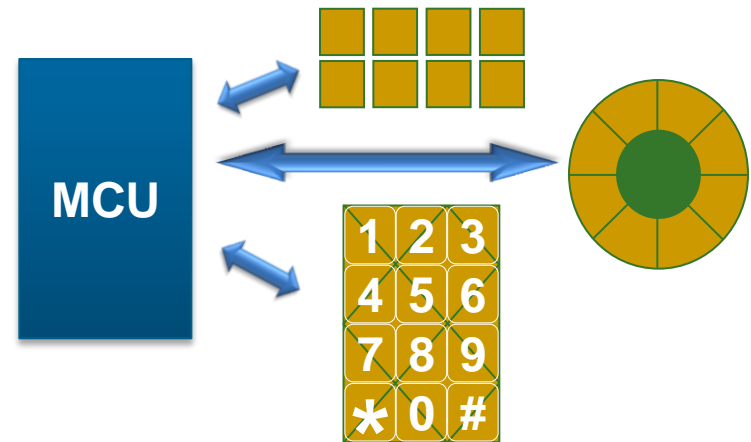

# Segment LCD Controller

## ▶ Segment fault detection capability

- Hardware support for segment LCD display errors

## ▶ Up to by 8 multiplexing

- Fewer pins required to drive LCD segments

## ▶ Low power blinking mode

- LCD glass blink capability in low power modes
- Alternate display feature can be activated to display alternate data (i.e. blink temperature and time)

## ▶ Front and back plane re-assignment

- Any LCD pin can be a frontplane or backplane pin or GPIO function

## ▶ Internal charge pump provides voltage required to power LCD glass

- Internally regulated voltage for constant contrast across MCU VDD
- Trim register for software contrast control
- Drive for 3V or 5V LCD glass

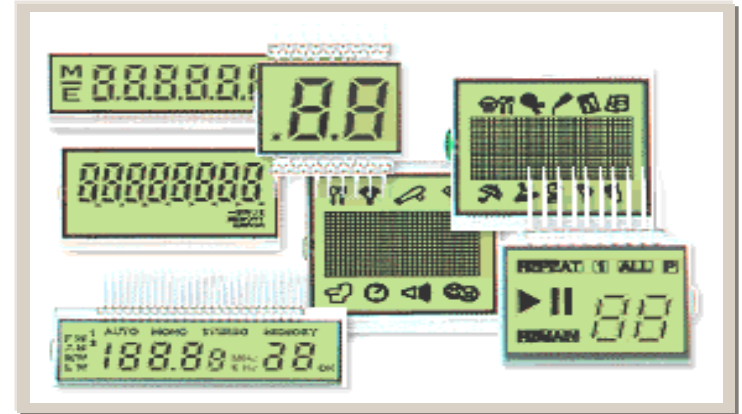



# Graphics LCD (GLCD) Controller

- ▶ Same IP as in the i.MX25x family
- ▶ Interface to passive and active color panel (TFT)
- ▶ Supports up to 8-bit QVGA displays using on-chip memory for frame buffer
- ▶ Hardware-generated cursor with blink, color, and size programmability
- ▶ Graphic window support for viewfinder function in color display
- ▶ 256 transparency levels for alpha blending between graphic window and background plane

# FlexTimer (FTM) Features

- ▶ Up to 4 FTM modules on Kinetis. FTM0 & FTM3 = 8 channels; FTM1 & FTM2 = 2 channels with quadrature decode
- ▶ 16-bit counter with prescaler divide-by 1,2,4,8,16,32,64, or 128
- ▶ Each channel can be configured for input capture, output compare, edge-aligned PWM mode, or center-aligned PWM mode
- ▶ Each pair of channels can be combined to generate a PWM signal with independent control of both edges of PWM signal
- ▶ Each pair can operate as complementary outputs with dead time insertion
- ▶ Dual edge capture for pulse and period width measurement
- ▶ Quadrature decoder with input filters for relative position counting
- ▶ Global Time Base mode shares single time base across multiple FTM instances

## Secure Real Time Clock

- On-chip, battery powered real-time clock
- Monotonic counter

## Secure Key Storage

- Instantly erased if tamper is detected

Independent power supply (1.71V to 3.6V)

Programmable alarm with interrupt

Hardware compensated clock

## Comprehensive Tamper Detection

- Temperature
- Clock
- Supply Voltage
- External tamper inputs

## Internal Tamper Detect sources:

- Seconds Counter overflow
- Atomic Counter overflow
- Flash Not Secure
- Tamper Interrupt Timeout
- Analog tamper sources
  - Clock monitor
  - High voltage detect
  - High/Low temperature detect

## External Tamper Detect sources:

- 4 Passive & 2 Active
- Each external tamper detect has a glitch filter
  - Configurable width from asynchronous to ~250 ms
  - Configurable polarity per pin
  - Pull-up/down enabled so that unconnected pin asserts tamper detect
  - Glitch Filter configured independently for each tamper input

# Low Power Timer (LPTMR) Features

- **Selectable clock for prescaler/glitch filter**
  - 1 kHz internal LPO
  - 32.768 kHz external crystal
  - Internal Reference Clock (not usable in low leakage modes)
- **Configurable Glitch Filter or Prescaler with 15-bit counter • 16-bit Time or Pulse Counter with Compare**
- **Interrupt generated on Timer Compare**
- **Hardware trigger generated on Timer Compare (not usable in low leakage modes)**
- **Can be used in conjunction with the HSCMP to count comparator output pulses**

# Programmable Delay Block (PDB)

## ► Features

- Provides controllable delays from either internal or external triggers
- Up to 15 trigger input sources and software trigger source
- Up to 8 configurable PDB channels for ADC hardware trigger
- Up to 8 DAC interval triggers
- Supports pulse outputs use as the sample window in CMP

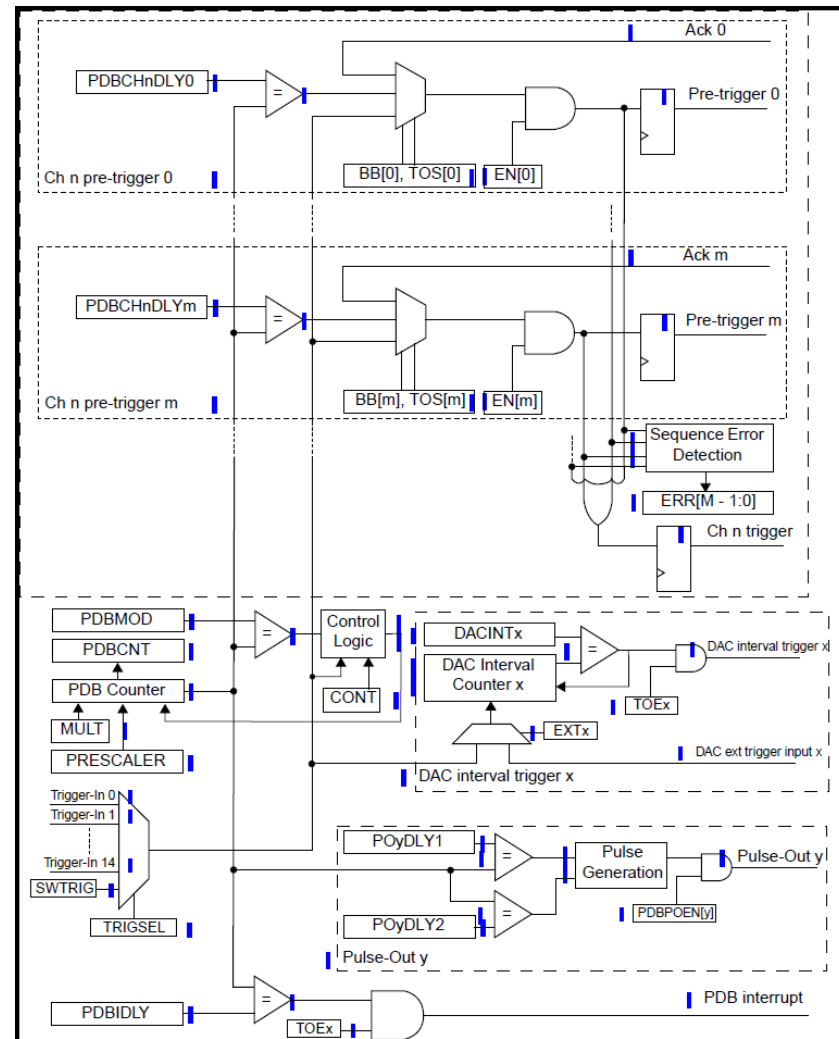



## Full/Low-speed

- ▶ **USB 1.1 and 2.0 compliant host, device and on-the-go (OTG) controller**
  - Supports Full-speed (12 Mbps) and low-speed (1.5 Mbps)
- ▶ **16 Bi-directional end points**
- ▶ **Paired with on-chip full/low-speed transceiver**
- ▶ **Built-in host mode pull down resistors**

## High/Full/Low-speed

- ▶ **Complies with USB2.0, supports host, device and OTG**
  - Supports High-speed (480 Mbps), Full-speed (12 Mbps) and low-speed host (1.5 Mbps)
  - On-chip transceiver supports full/low-speed modes
  - External transceiver via ULPI interface needed for high-speed modes
  - Allows direct connection of full-speed (FS) or low-speed (LS) devices without an OHCI/UHCI companion controller
- ▶ **Defined as any USB class or device for targeted peripheral list, incl. hubs**
- ▶ **Suspend/low power mode**
  - Can suspend individual devices or the entire USB subsystem
  - Remote wake-up integrated with processor's low power modes

# USB Regulator

- ▶ 5V regulator input (VREGIN) typically provided by USB Vbus or Rechargeable Battery power
- ▶ 3.3V regulated output powers on-chip USB transceiver and device charger detect
- ▶ Output pin (VOUT33) from regulator can be used to power external board components and source up to 120mA
- ▶ Eliminates cost of external LDO
- ▶ 3.3V regulated output can power MCU main power supply

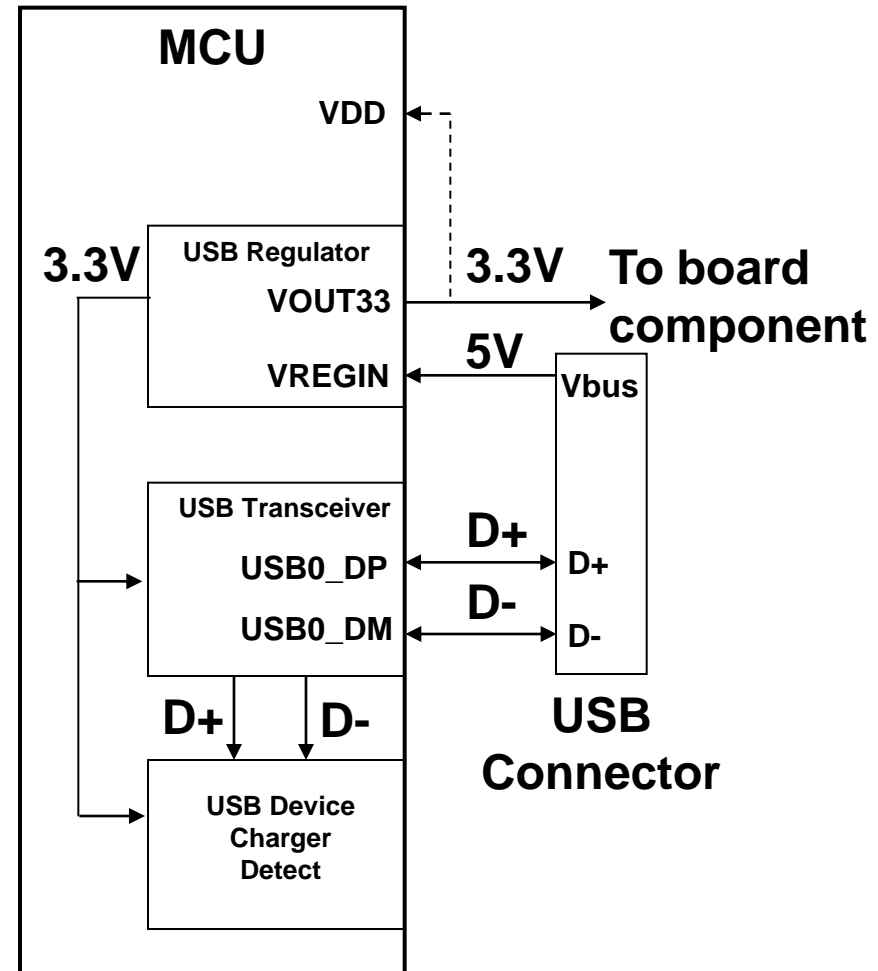

# USB Device Charger Detect

- ▶ Compliant with the latest industry standard specification: *USB Battery Charging Specification, Revision 1.1*
- ▶ Compatible with systems powered from:
  - rechargeable battery
  - non-rechargeable battery
  - external 3.3v LDO regulator powered from USB
  - directly from USB using internal regulator

Charger	Maximum Current Drawn <sup>1</sup>
Standard host port	up to 500 mA
Charging host port	up to 1500 mA
Dedicated charging port	up to 1800 mA

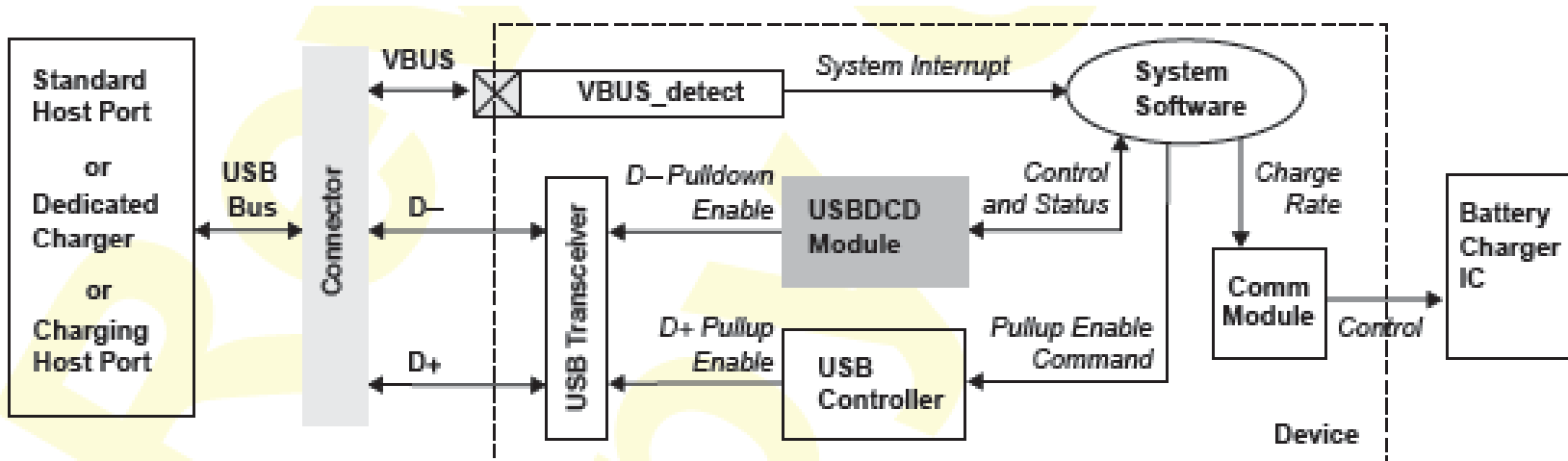

# IEEE 1588 Ethernet Controller

- ▶ **Implements the full 802.3 specification**
  - Dynamically configurable to support 10/100 Mbps operation
  - Supports full duplex (w/flow control) and configurable half duplex operation
  - Support for VLAN-tagged frames according to IEEE 802.1Q
- ▶ **Supports AMD magic packet detection with interrupt for node remote power management**
- ▶ **Seamless interface to commercial Fast Ethernet PHYs**
  - Supports MII and RMII interfaces
  - MDIO master interface for PHY device configuration and management
- ▶ **Programmable MAC address: discards frames with mismatching destination address on receive (except broadcast and pause frames)**
- ▶ **Hardware time stamping support for IEEE 1588 provides precision clock synchronization for real-time control**

## Freescale Confidential and Proprietary

Freescale, the Freescale logo, CodeWarrior, ColdFire and PowerQuicc are trademarks of Freescale Semiconductor, Inc., Reg. U.S. Pat. & Tm. Off. Flexis, Processor Expert and QorIQ are trademarks of Freescale Semiconductor, Inc. All other product or service names are the property of their respective owners. The Power Architecture and Power.org word marks and the Power and Power.org logos and related marks are trademarks and service marks licensed by Power.org. ARM is the registered trademark of ARM Limited. ARM Cortex-M4 and ARM Cortex-M3 are trademarks of ARM Limited. © 2010 Freescale Semiconductor, Inc.

- ▶ **Full duplex serial port that allows communication with a variety of serial devices:**
  - Audio codecs that implement the inter-IC sound bus (I2S)
  - Standard codecs
  - Digital signal processors (DSPs)
  - Microprocessors
  - Peripherals
  - AC97 support
- ▶ **Independent (asynchronous) or shared (synchronous) transmit and receive sections with separate or shared internal/external clocks and frame syncs, operating in Master or Slave mode**
  - Completely separate clock and frame sync selections for the receive and transmit sections. In the AC97 standard, the clock is taken from an external source and frame sync is generated internally
- ▶ **Supports several synchronous operating modes:**
  - Normal mode operation using frame sync
  - Network mode operation allowing multiple devices to share the port with as many as thirty-two time slots
  - Gated clock mode operation requiring no frame sync
  - Programmable data interface modes such as I2S, lsb- and msb-aligned
- ▶ **2 sets of Transmit and Receive FIFOs**
  - Each of the four FIFOs is 15x32 bits
  - Can be used in Network mode to provide 2 independent channels for transmission and reception
- ▶ **Programmable word length (8, 10, 12, 16, 18, 20, 22 or 24 bits)**
- ▶ **Program options for frame sync and clock generation**
- ▶ **Programmable I2S modes (master, slave or normal). Oversampling clock (ccm\_ssi\_clk) available as output from SRCK in I2S master mode**
- ▶ **Option to use internal system clock as or an external input clock**

# UART Instantiation on Kinetis

SCI Instance	Features	Maximum Baud Rate
UART0	Higher Baud Rates (CPUCLK @ 100 MHz) ISO-7816 8 TX and 8 RX FIFOs	6.25 Mbits/sec
UART1	Higher Baud Rates (CPUCLK @ 100 MHz) 8 TX and 8 RX FIFOs	6.25 Mbits/sec
UART2-UART5	Normal Baud Rates (BUSCLK @ 50 MHz) 1 TX and 1 RX FIFO	3.13 Mbits/sec

$$\text{SCI baud rate} = \text{SCI module clock} / (16 * (\text{SBR}[12:0] + \text{BRFD}))$$

## Freescal Confidential and Proprietary

Freescal, the Freescal logo, CodeWarrior, ColdFire and Powerquicc are trademarks of Freescal Semiconductor, Inc., Reg. U.S. Pat. & Tm. Off. Flexis, Processor Expert and QorIQ are trademarks of Freescal Semiconductor, Inc. All other product or service names are the property of their respective owners. The Power Architecture and Power.org word marks and the Power and Power.org logos and related marks are trademarks and service marks licensed by Power.org. ARM is the registered trademark of ARM Limited. ARM Cortex-M4 and ARM Cortex-M3 are trademarks of ARM Limited. © 2010 Freescal Semiconductor, Inc.



- ▶ **Full-duplex operation**
- ▶ **Standard mark/space non-return-to-zero (NRZ) format**
- ▶ **Selectable IrDA 1.4 return-to-zero-inverted (RZI) format with programmable pulse widths**
- ▶ **13-bit baud rate selection with /32 fractional divide, based on module clock frequency**
- ▶ **Programmable 8-bit or 9-bit data format**
- ▶ **Separately enabled transmitter and receiver with programmable input/output polarity**

# UART (continued)

- ▶ **13-bit break character option**
- ▶ **11-bit break character detection option**
- ▶ **Independent FIFO structure for transmit and receive**
- ▶ **Multi-drop support: address match feature in receiver to reduce address mark wakeup ISR overhead**
- ▶ **Ability to select MSB or LSB to be first bit on wire**
- ▶ **Hardware flow control support for request to send (RTS) and clear to send (CTS) signals**
- ▶ **Support for ISO-7816 protocol for interfacing with smartcards**

## **Freescale Confidential and Proprietary**

Freescale, the Freescale logo, CodeWarrior, ColdFire and PowerQuicc are trademarks of Freescale Semiconductor, Inc., Reg. U.S. Pat. & Tm. Off. Flexis, Processor Expert and QorIQ are trademarks of Freescale Semiconductor, Inc. All other product or service names are the property of their respective owners. The Power Architecture and Power.org word marks and the Power and Power.org logos and related marks are trademarks and service marks licensed by Power.org. ARM is the registered trademark of ARM Limited. ARM Cortex-M4 and ARM Cortex-M3 are trademarks of ARM Limited. © 2010 Freescale Semiconductor, Inc.

## ▶ Serial Peripheral Interface bus:

- Full-duplex, three-wire synchronous transfers
- Master and slave modes
- Maximum master mode frequency is CPU freq/4 (ex. 100MHz/4 = 25MHz)
- Maximum slave mode frequency is CPU freq/8 (ex. 100MHz/8 = 12.5MHz)

## ▶ Buffered transmit and receive operation with 4 entry Rx and Tx FIFOs

## ▶ Programmable transfer attributes on a per-frame basis:

- Parameterized number of transfer attribute registers (from two to six depending on device and particular SPI instantiation)
- Serial clock with programmable polarity and phase
- Various programmable delays
- Programmable transfer size of 4 to 16 bits
- Continuously held chip select capability (for the length of the FIFO)

## ▶ Up to 6 Peripheral Chip Selects, expandable with an external demultiplexer

- Exact number of chip selects depend on device and particular SPI instantiation (different SPIs on same device can have different number of chip selects)

## ▶ DMA support for adding entries to TX FIFO and removing entries from RX FIFO:

## ▶ Modified SPI transfer formats for communication with slower peripheral devices

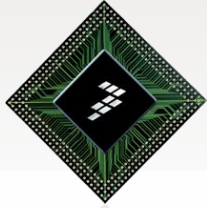

# Building the Industry's Most Trusted MCU Solutions

## ► Freescale offers leadership in the 32-bit MCU space

1. 200 scalable devices from 32KB to 1MB of flash and up to 150MHz performance
2. FlexMemory enables on-chip EEPROM
3. Incredible mixed-signal integration
4. Low-power capability
5. Complete enablement
  - Complimentary MQX RTOS
  - Complimentary CodeWarrior IDE
  - Tower system for rapid prototyping

## ► **Kinetis by Freescale is the clear choice for your MCU needs**

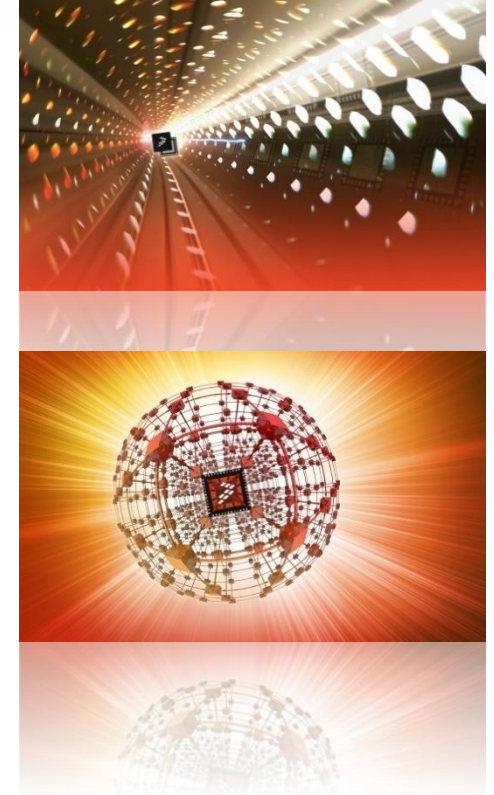





# BACK-UP



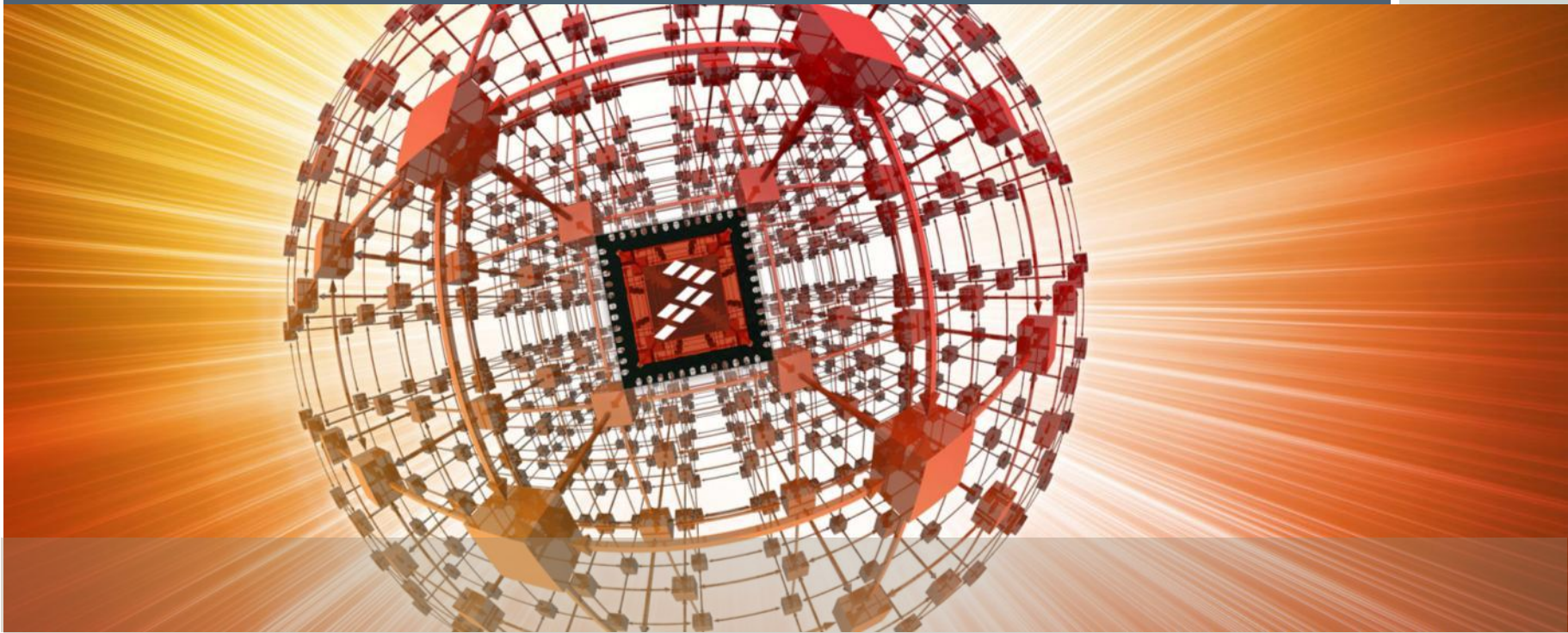

# Get to Know your Tower System

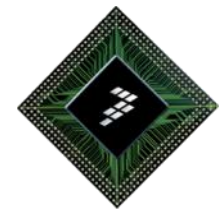

# The Tower System

## Processor Module:

- Tower controller board
- Works stand-alone or in Tower system
- Features new Open Source BDM (OSBDM) for easy programming and debugging via miniB USB cable

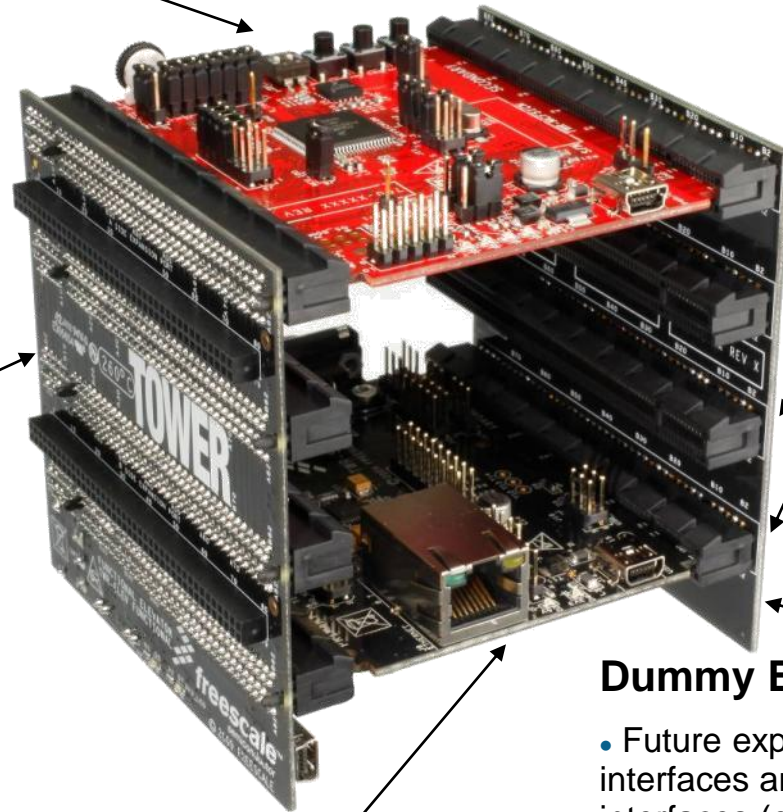

## Functional Elevator:

- Common serial and expansion bus signals
- Two 2x80 connectors on backside for easy signal access and side-mounting board (e.g. LCD module)
- Power regulation circuitry
- Standardized signal assignments (e.g. UART, SPI, Timers, External Bus, I2C, CAN, GPIO, Ethernet, USB, etc.)

## Peripheral Module:

Standard peripheral boards compatible with all controller boards (e.g. Serial, Memory, etc.)

**Size:** The Tower is approx. 3.5" H x 3.5" W x 3.5" D when fully assembled

## Board Connectors:

- Four card-edge connectors
- Uses PCI Express connectors (x16, 90mm/3.5" long, 164 pins)

## Dummy Elevator:

- Future expansion for more serial interfaces and more complex MPU interfaces (e.g. RGB LCD, segment LCD, audio, enhanced Timer, etc.)
- "Dummy" shown with only GND connectivity. Used for structural integrity



# Get to Know the TWR-K60N512 (front)



Figure 1: Front side of TWR-K60N512 Module not including TWRPI.

# Get to Know the TWR-K60N512 (back)

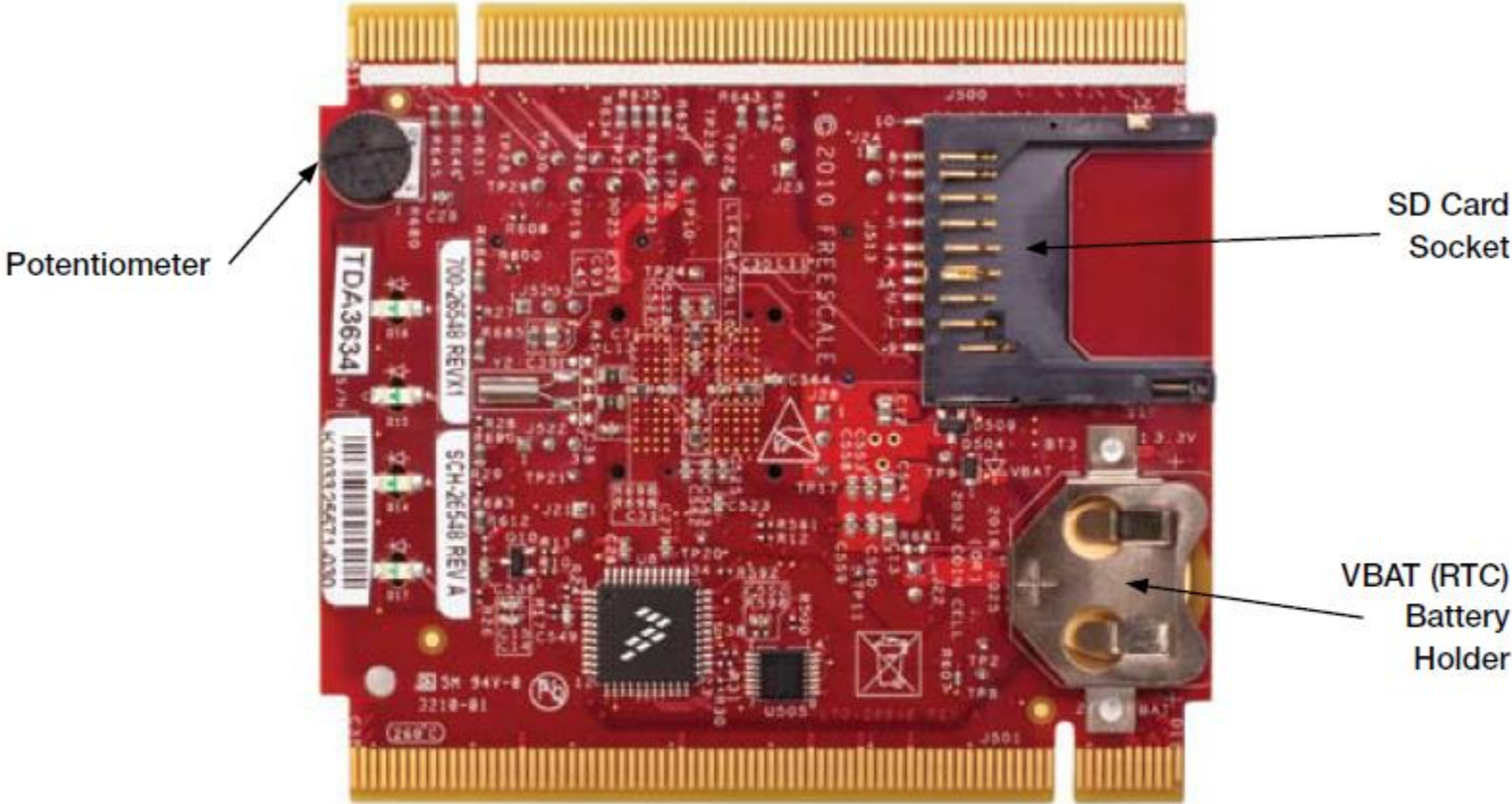

Figure 2: Back side of TWR-K60N512 Module.



# Get to Know the TWR-K40X256 (front)



Figure 1: Front side of TWR-K40X256 Module not including TWRPI.

# Get to Know the TWR-K40X256 (back)

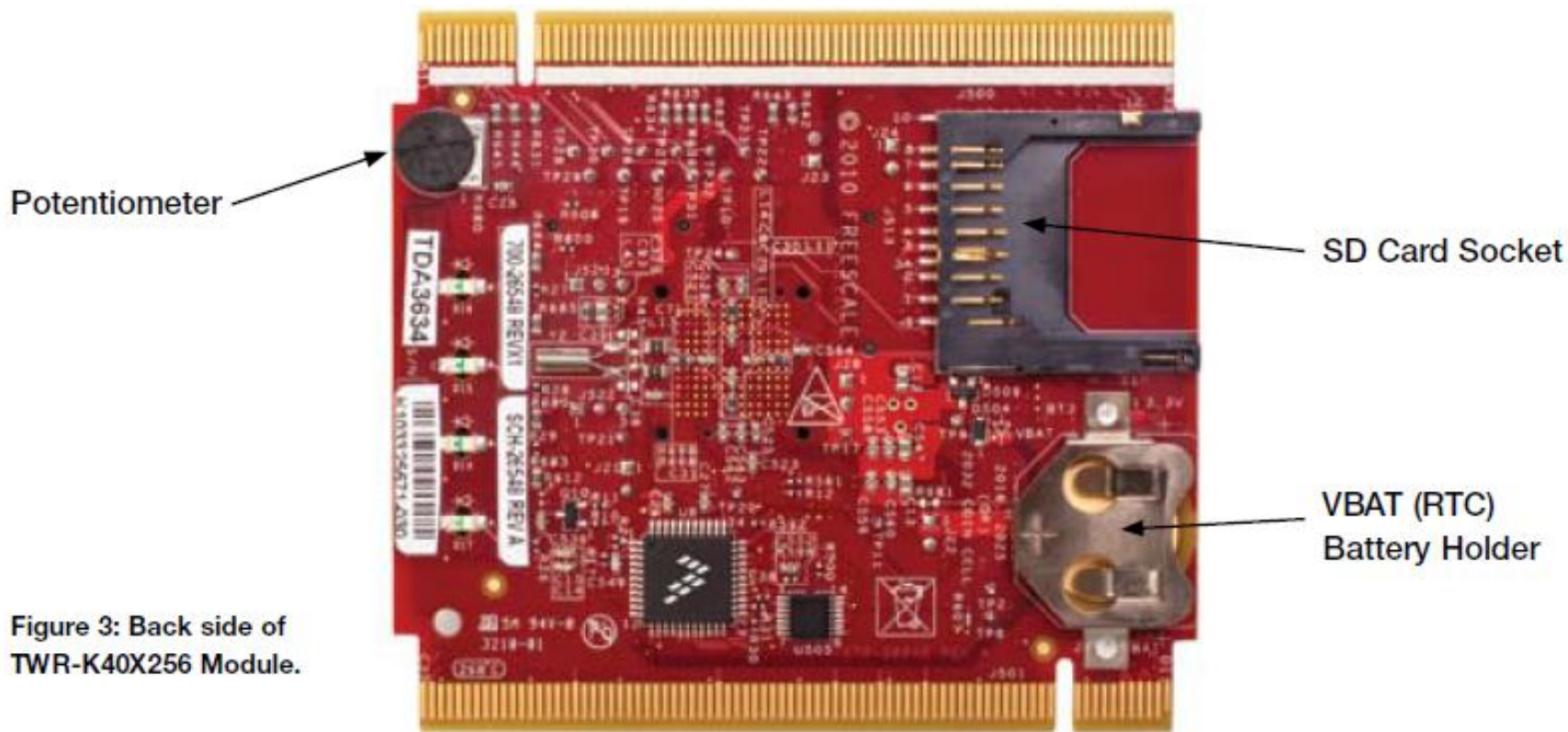

Figure 3: Back side of TWR-K40X256 Module.



# TWR-K40X256 with TWRPI-SLCD



Figure 2: Front side of TWR-K40X256 Module with TWRPI-SLCD attached.

# Available Tower System Modules

[www.freescale.com/tower](http://www.freescale.com/tower)

**New**

Processor  
Modules  
(\$39-\$119)



TWR-MCF51CN



TWR-MCF5225X



TWR-S08LL64



TWR-MPC5125



TWR-MCF51MM  
TWR-S08MM128  
TWR-MCF51JE-KIT



TWR-K60N512  
TWR-K40X256  
TWR-MCF5441X  
TWR-MCF51AG  
TWR-56F8257

Coming Soon

Peripheral  
Modules  
(\$15 - \$149)



TWR-SER

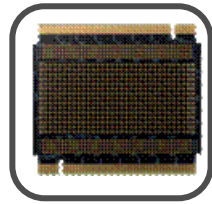

TWR-PROTO



TWR-ELEV



TWR-MEM

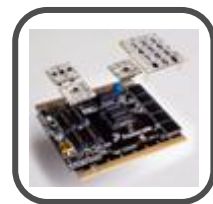

TWR-SENSOR-PAK



TWR-LCD



MED-EKG

**New**

Coming  
Soon



TWR-WIFI-RS2101  
Sept 20



TWR-WIFI-G1011MI  
Oct 21



TWR-ADCDAC-LTC  
Jan 2011

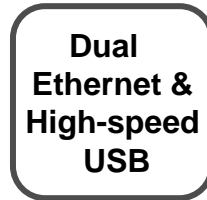

TWR-SER2  
Sept 27



TWR-AUDIO  
Q4 2010

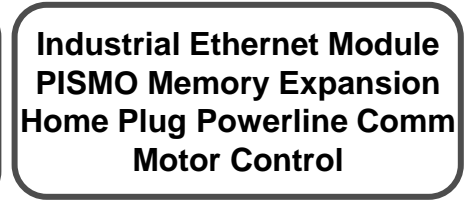

Under Development



# Peripheral Module: TWR-SER Serial Module

## TWR-SER



*Add Serial connectivity to your design*

### **Features:**

- RS232 and RS485
- Ethernet
- CAN
- USB

### **Resale:**

**TWR-SER = \$29**

[www.freescale.com/tower](http://www.freescale.com/tower)

# Peripheral Module: TWR-WIFI-RS2101 802.11n Wi-Fi Module

## TWR-WIFI-RS2101



### **Features:**

- RS9110-N-11-21 Wi-Fi® module from Redpine Signals
- Compliant to 802.11b/g and single stream 802.11n
- Supports all Wi-Fi client security protocols (WEP, WPA and WPA2)
- Reference design certified for FCC/IC/CE
- RoHS compliant
- Does not require any WLAN driver on the host processor
- Interfaces to MCU via SPI, UART
- Terminates SLIP connections and offers transparent serial modem functionality
- Integrated antenna, frequency reference and low-frequency clock
- Ultra-low-power operation with power save modes
- Ad-hoc and infrastructure modes for maximum deployment flexibility
- Single supply 3.1 to 3.6V operation

### **Resale:**

**TWR-WIFI-RS2101= \$69**

# Peripheral Module: TWR-WIFI-G1011MI 802.11b Wi-Fi Module

## TWR-WIFI-G1011MI



### **Resale:**

TWR-WIFI-G1011MI= \$69

### **Features:**

- Features GS1011MIP Wi-Fi module from GainSpan
- Operates with standard 802.11 b/g/n access points at speeds up to 11 Mbps
  - Infrastructure or Adhoc mode
  - UART and SPI interfaces
  - Up to 3 Mbps in SPI Slave Mode
  - Up to 921.6 kbps on UART
- Full Wi-Fi stack including WPS and optional networking stack and services
- 802.11i Security
  - WEP, WPA, WPA2-PSK, Enterprise
- Certified RF Module: Wi-Fi, FCC, IC, Japan, ETSI, RoHS

### **Partner:**

GainSpan (<http://www.gainspan.com/>)



# Peripheral Module: TWR-PROTO Prototyping Module

## TWR-PROTO

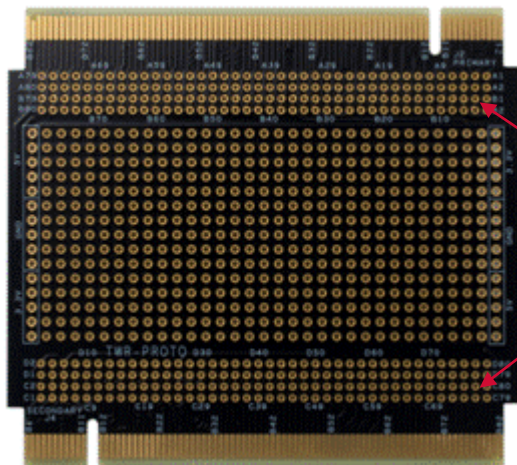

*Add custom circuitry easily!*

### **Features:**

- Access to all signals
- Generous 8.3 x 3.8cm prototyping area
- 3.3V, 5V and GND

### **Resale:**

**TWR-PROTO = \$14.99**

[www.freescale.com/tower](http://www.freescale.com/tower)

# Peripheral Module: TWR-MEM Memory Module

## TWR-MEM



### ***Features:***

- CPLD
- Compact flash interface
- Secure digital interface
- MRAM
- Serial flash

### ***Resale:***

**TWR-MEM = \$89**





# Peripheral Module: TWR-LCD Graphical LCD Module

## TWR-LCD



### **Features:**

- 3.2" TFT QVGA display
- SPI and CPU interface
- Resistive touch screen interface
- 5-position navigation switch
- Piezzo buzzer
- microSD card slot
- Standalone mode

### **Resale:**

**TWR-LCD = \$99**



# Peripheral Module: TWR-SENSOR-PAK Sensor Module

## TWR-SENSOR-PAK

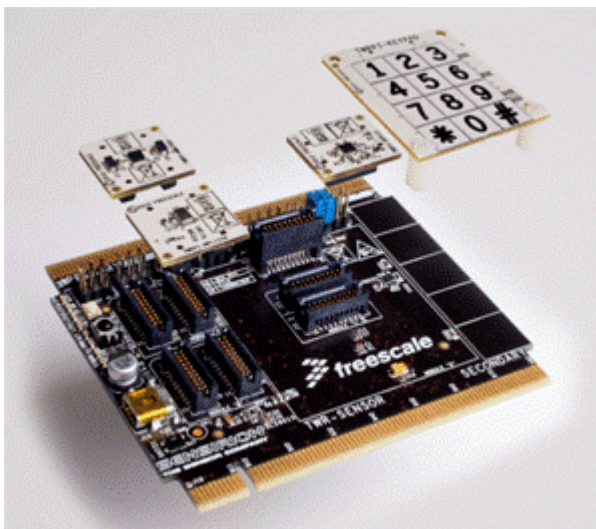

### ▶ Swappable Freescale Sensor Modules

- Touch Sense Controller (MPR121)
- Accelerometer (MMA7660, MMA6900, MMA8450)
- Pressure Sensor (MPL115A)

### ▶ Swappable Touch Pad Modules

- Keypad
- Rotary

### ▶ On-board Slider / Touch Pad

- With dedicated Touch Sense Controller (MPR032)

### ▶ On-board MCU (MC9S08QE96)

- Stand-alone operation
- Slave MCU mode
- Touch Sense Software

### ▶ On-Board 3<sup>rd</sup> Party Sensors

- Temperature / Humidity
- Ambient Light / Proximity
- IR Receiver

### ▶ OSBDM / Serial-to-USB

- Onboard MC9S08JM60
- OSBDM support for QE96
- Serial-to-USB support

### *Resale:*

**TWR-SENSOR-PAK = \$139**

# Peripheral Module: MED-EKG Electrocardiograph

## MED-EKG

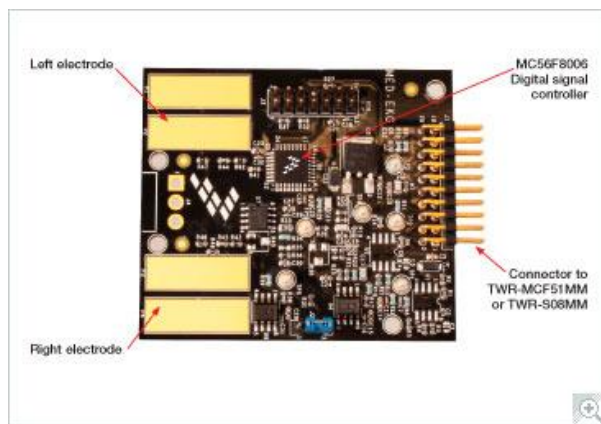

- ▶ Freescale Tower System compliant
- ▶ Small form factor
- ▶ External connector to TWR-S08MM128 and TWR-MCF51MM
- ▶ Includes the MC56F8006 DSC used for data filtering
- ▶ Electrodes embedded in development board for easy EKG signal detection
- ▶ Open connector for any type of EKG electrodes for additional precision

### **Resale:**

**TWR-SENSOR-PAK = \$35**

# Xtrinsic Touch Sensing Software 2.0 Key Features

- ▶ Full API set support
- ▶ Support up to 64 electrodes
- ▶ No need of extra IC
- ▶ Configurable rotary, slider and keypad decoders with optimized buffer structure enabling any arrangement of electrodes.
- ▶ Smart auto-calibration mechanisms to prevent environmental hassles
- ▶ Noise rejection algorithms, new IIR filtering
- ▶ New KBI and IC functions for TSS ATL method
- ▶ Ability to enable and disable keys on runtime
- ▶ Auto repeat, stuck-up key, gorilla hand and other typical HMI function capabilities
- ▶ Ability to co-exist with other application code
- ▶ PC GUI application for electrode characterization
- ▶ Support multiple communication protocols: I2C, LIN, CAN , SPI, USB and more
- ▶ Possibility to have other peripherals working at the same time: LCD, LEDs, buzzer, ADC, other sensors, and more.

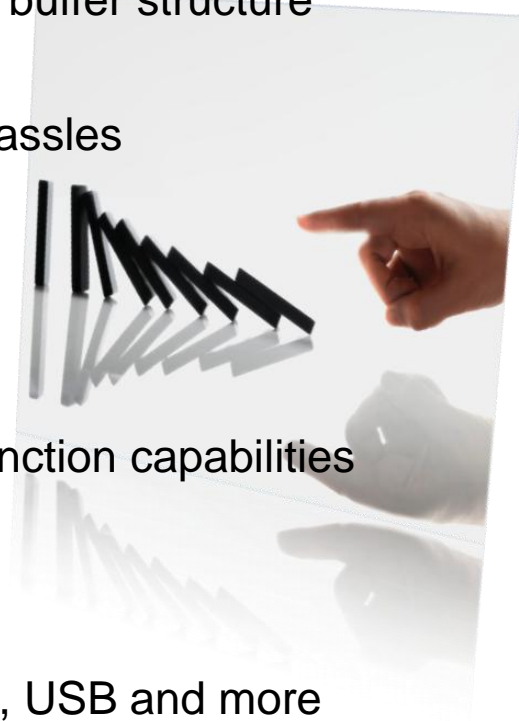



Компания «Life Electronics» занимается поставками электронных компонентов импортного и отечественного производства от производителей и со складов крупных дистрибьюторов Европы, Америки и Азии.

С конца 2013 года компания активно расширяет линейку поставок компонентов по направлению коаксиальный кабель, кварцевые генераторы и конденсаторы (керамические, пленочные, электролитические), за счёт заключения дистрибьюторских договоров

Мы предлагаем:

- Конкуренспособные цены и скидки постоянным клиентам.
- Специальные условия для постоянных клиентов.
- Подбор аналогов.
- Поставку компонентов в любых объемах, удовлетворяющих вашим потребностям.
- Приемлемые сроки поставки, возможна ускоренная поставка.
- Доставку товара в любую точку России и стран СНГ.
- Комплексную поставку.
- Работу по проектам и поставку образцов.
- Формирование склада под заказчика.
- Сертификаты соответствия на поставляемую продукцию (по желанию клиента).
- Тестирование поставляемой продукции.
- Поставку компонентов, требующих военную и космическую приемку.
- Входной контроль качества.
- Наличие сертификата ISO.

В составе нашей компании организован Конструкторский отдел, призванный помогать разработчикам, и инженерам.

Конструкторский отдел помогает осуществить:

- Регистрацию проекта у производителя компонентов.
- Техническую поддержку проекта.
- Защиту от снятия компонента с производства.
- Оценку стоимости проекта по компонентам.
- Изготовление тестовой платы монтаж и пусконаладочные работы.



Тел: +7 (812) 336 43 04 (многоканальный)  
Email: [org@lifeelectronics.ru](mailto:org@lifeelectronics.ru)