



Main

Range of product	Magelis STO & STU
Product or component type	Touch panel screen
Software designation	Vijeo XD
Operating system	Magelis

Complementary

Display size	4.3 inch
Display type	Colour TFT LCD
Display colour	65536 colours
Display resolution	480 x 272 pixels
Touch panel	Analogue
Backlight lifespan	50000 hours with white
Brightness	16 levels via touch panel
Character font	ASCII (European characters) Chinese (simplified Chinese) Cyrillic Japanese (ANK, Kanji) Korean Taiwanese (traditional Chinese)
[Us] rated supply voltage	12...24 V DC - 10...20 %
Power consumption in W	7.5 W
Number of pages	8999
Memory description	Back up of data, 512 kB Application memory, 26 MB
Integrated connection type	1 USB 2.0 type mini B 1 USB 2.0 type A 1 RJ45 connector serial link with RS232C/RS485 interface at 2400...115200 bps
Supply	External source
Realtime clock	With RTC-battery set (optional)
Downloadable protocols	Modbus Third party protocols
Range compatibility	Omron Allen-Bradley Mitsubishi Siemens
Fixing mode	By 2 installation fasteners on 1.5 to 6 mm thick panel
Enclosure material	PPT
Front material	Plastic
Cut-out dimensions	77.5 x 112.5 mm 66 x 105 mm (with mounting adaptor)
Product weight	0.49 lb(US) (0.22 kg)

Environment

standards	CSA C22.2 No 142 EN 61000-6-2 EN 61000-6-4
-----------	--

EN 61131-2
 UL 61010-1
 CSA C22.2 No 213
 ANSI/ISA 12.12.01
 UL 61010-2-201

product certifications	ATEX zone 2/22 CE C-Tick CUL UL KCC
directives	2002/96/EC - WEEE directive 2002/95/EC - RoHS directive 1907/2006/EC - REACH directive
ambient air temperature for operation	32...122 °F (0...50 °C)
ambient air temperature for storage	-4...140 °F (-20...60 °C)
relative humidity	10...90 % without condensation
operating altitude	6561.68 ft (2000 m)
IP degree of protection	IP20 (rear panel) IP65f (front panel)
NEMA degree of protection	NEMA 4X/13 front panel (indoor use)
shock resistance	15 gn for 11 ms conforming to IEC 61131-2
vibration resistance	1 gn (f = 5...150 Hz) conforming to IEC 61131-2 3.5 mm constant amplitude (f = 5...150 Hz) conforming to IEC 61131-2
electromagnetic compatibility	Resistance to radiated electromagnetic fields : 10 V/m 80 MHz...2.7 GHz Resistance to electrostatic discharge : 8 kV air discharge conforming to EN 61000-4-2 level 3 Resistance to electrostatic discharge : 6 kV direct contact conforming to EN 61000-4-2 level 3

Offer Sustainability

Green Premium product	Green Premium product
Compliant - since 1601 - Schneider Electric declaration of conformity	Compliant - since 1601 - Schneider Electric declaration of conformity
Reference not containing SVHC above the threshold	Reference not containing SVHC above the threshold
Available	Available
Available	Available
WARNING: This product can expose you to chemicals including:	WARNING: This product can expose you to chemicals including:
Lead and lead compounds, which is known to the State of California to cause cancer and birth defects or other reproductive harm.	Lead and lead compounds, which is known to the State of California to cause cancer and birth defects or other reproductive harm.
For more information go to www.p65warnings.ca.gov	For more information go to www.p65warnings.ca.gov

External Dimensions

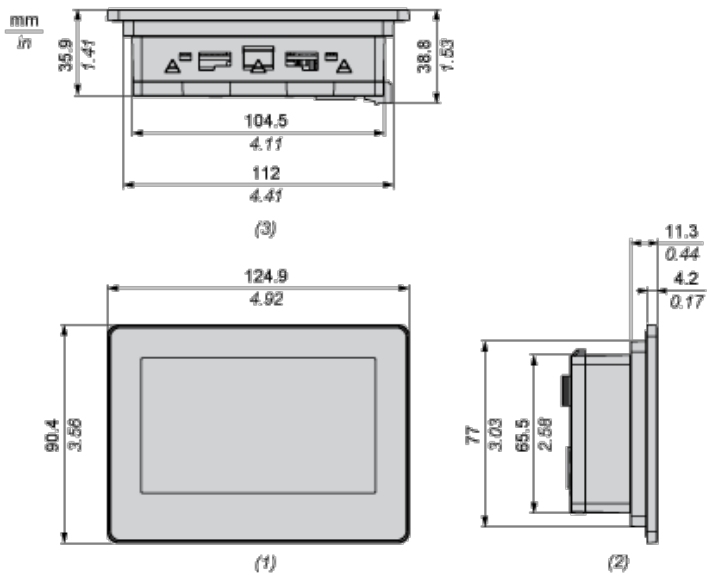

- 1 Front
- 2 Left
- 3 Bottom

Dimensions with Installation Fasteners

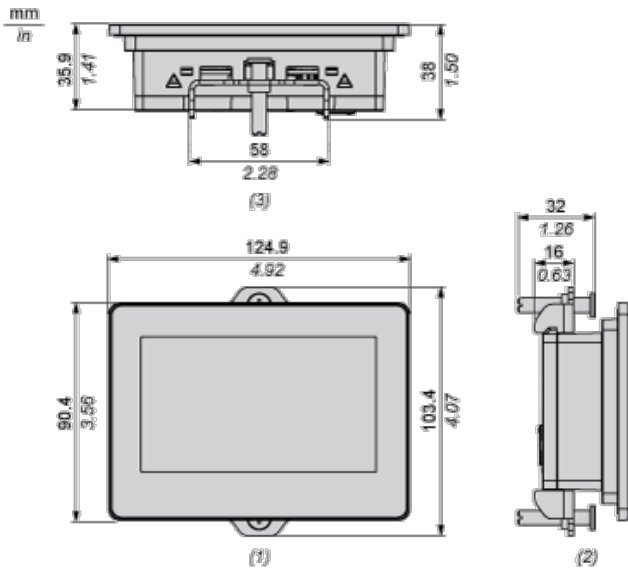

- 1 Front
- 2 Left
- 3 Bottom

Mounting

Panel Cut-out Dimensions

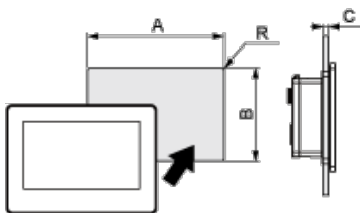

Dimensions in mm

Description	A	B	C	R
Without adapter	112.5	77.5	1.5...6	3 max.

With adapter	105	66	1.5...6	3 max.
--------------	-----	----	---------	--------

Dimensions in in.

Description	A	B	C	R
Without adapter	4.43	3.05	0.06...0.24	0.12 max.
With adapter	4.13	2.6	0.06...0.24	0.12 max.

Installation Requirements

Mounting Angle

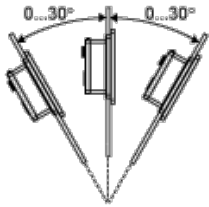

When installing this product in a slanted position with an incline more than 30°, the ambient temperature must not exceed 40 °C (104 °F). You may need to use forced air cooling (fan, A/C) to ensure the ambient operating temperature is 40 °C or less (104 °F or less).

Clearance

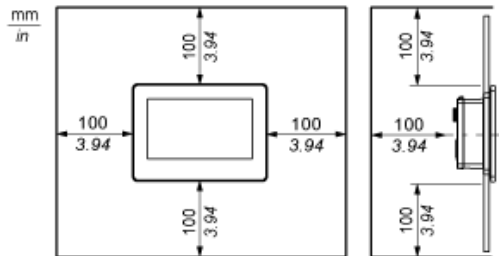

Компания «Life Electronics» занимается поставками электронных компонентов импортного и отечественного производства от производителей и со складов крупных дистрибьюторов Европы, Америки и Азии.

С конца 2013 года компания активно расширяет линейку поставок компонентов по направлению коаксиальный кабель, кварцевые генераторы и конденсаторы (керамические, пленочные, электролитические), за счёт заключения дистрибьюторских договоров

Мы предлагаем:

- Конкуренспособные цены и скидки постоянным клиентам.
- Специальные условия для постоянных клиентов.
- Подбор аналогов.
- Поставку компонентов в любых объемах, удовлетворяющих вашим потребностям.
- Приемлемые сроки поставки, возможна ускоренная поставка.
- Доставку товара в любую точку России и стран СНГ.
- Комплексную поставку.
- Работу по проектам и поставку образцов.
- Формирование склада под заказчика.
- Сертификаты соответствия на поставляемую продукцию (по желанию клиента).
- Тестирование поставляемой продукции.
- Поставку компонентов, требующих военную и космическую приемку.
- Входной контроль качества.
- Наличие сертификата ISO.

В составе нашей компании организован Конструкторский отдел, призванный помогать разработчикам, и инженерам.

Конструкторский отдел помогает осуществить:

- Регистрацию проекта у производителя компонентов.
- Техническую поддержку проекта.
- Защиту от снятия компонента с производства.
- Оценку стоимости проекта по компонентам.
- Изготовление тестовой платы монтаж и пусконаладочные работы.



Тел: +7 (812) 336 43 04 (многоканальный)

Email: org@lifeelectronics.ru