



All numerical values are in metric units [with U.S. customary units in brackets]. Dimensions are in millimeters [and inches]. Unless otherwise specified, dimensions have a tolerance of  $\pm 0.13$  [ $\pm .005$ ] and angles have a tolerance of  $\pm 2^\circ$ . Figures and illustrations are for identification only and are not drawn to scale.

**1. INTRODUCTION**

This specification covers the requirements for spring probe miniature CPCs in wire-to-wire free-hanging application. The connectors consist of a plug assembly and receptacle assembly. The connectors are available in a shell size 8 having 4 contact positions. Each connector contains solder cup contacts for wire termination. The connectors are designed to accept a strain relief assembly which can be used if the wires are subject to strain. The strain relief assembly is available separately in a right-angle or vertical configuration.

When corresponding with personnel, use the terminology provided in this specification to facilitate your inquiries for information. Basic terms and features of this product are provided in Figure 1.

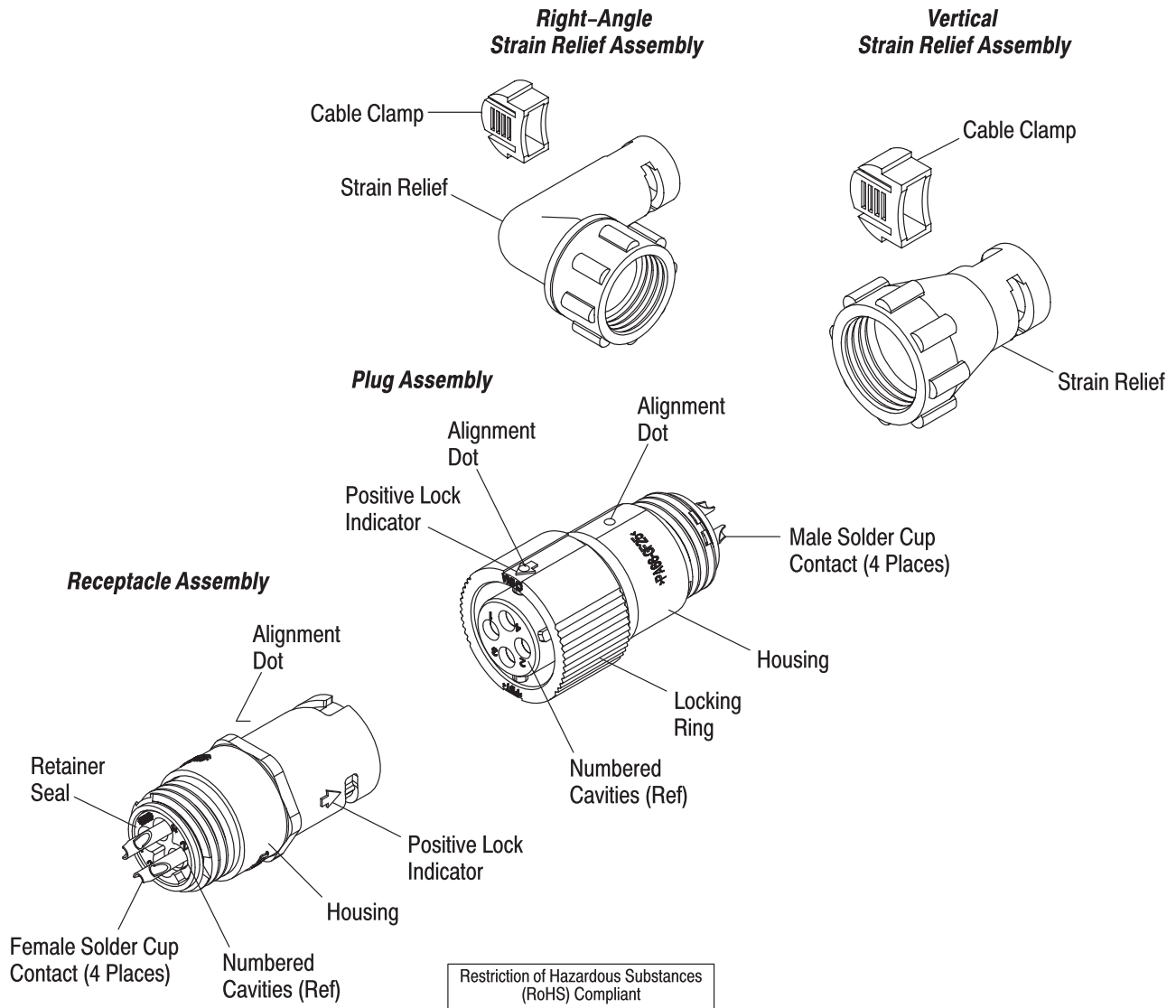

Figure 1

The plug assembly features a housing which contains male contacts and a locking ring. The housing is embossed with an alignment dot, and the locking ring is embossed with a positive lock indicator (arrow) and an alignment dot.

The receptacle assembly features a housing which contains female contacts. Each female contact has a piston which contains a spring. The housing also contains a wire entry seal, retainer seal, and peripheral seal. These seals prevent elements from entering the cavities and housing. The housing is embossed with an alignment dot and a positive lock indicator (arrow).

The cavities of each connector are marked on the mating face and the wire end to aid in proper circuit connection. Before engaging the connectors, the alignment dots are used for proper alignment. When engaged, the locking ring must be rotated to fully mate and lock the connector together.

## 2. REFERENCE MATERIAL

### 2.1. Revision Summary

Revisions to this application specification include:

- Updated document to corporate requirements
- Modified Paragraph 2.5

### 2.2. Customer Assistance

Reference Product Base Part Number 1877157 and Product Code H314 are representative of spring probe miniature CPCs. Use of these numbers will identify the product line and expedite your inquiries through a service network established to help you obtain product and tooling information. Such information can be obtained through a local Representative or, after purchase, by calling PRODUCT INFORMATION at the number at the bottom of page 1.

### 2.3. Drawings

Customer Drawings for product part numbers are available from the service network. If there is a conflict between the information contained in the Customer Drawings and this specification or with any other technical documentation supplied, call PRODUCT INFORMATION at the number at the bottom of page 1.

### 2.4. Standards and Publications

Association of Connecting Electronics Industries (IPC)–S–815, “General Requirements for Soldering Electronic Interconnections,” provides guidelines for establishing quality soldering for solder cup contacts.

### 2.5. Specifications

Product Specifications (108–series) provide product performance and test information. Documents available which pertain to this product are:

- 108–1943 Spring Probe Connector
- 108–2280 Mini–CPC Spring Probe Connector System

### 2.6. Instructional Material

There is no instructional material available for this product.

## 3. REQUIREMENTS

### 3.1. Safety

Do not stack product shipping containers so high that the containers buckle or deform.

### 3.2. Material

The connector housing, locking ring, and retainer seal are made of high temperature thermoplastic, UL94–V–0. Each contact body is made of brass plated with gold over nickel. The contact spring is made of stainless steel. The wire entry seal (yellow or white) and peripheral seal (gray) are made of elastomer.

### 3.3. Storage

#### A. Ultraviolet Light

Prolonged exposure to ultraviolet light may deteriorate the chemical composition used in product material.

**B. Shelf Life**

Product should remain in the shipping containers until ready for use to prevent deformation to components. Product should be used on a first in, first out basis to avoid storage contamination that could adversely affect performance.

**C. Chemical Exposure**

Do not store product near any chemical listed below as they may cause stress corrosion cracking in the components.

Alkalies	Ammonia	Citrates	Phosphates	Citrates	Sulfur Compounds
Amines	Carbonates	Nitrites	Sulfur Nitrites		Tartrates

**3.4. Wire Selection and Preparation**

The contacts will accept solid or stranded wire with an individual wire size range of 30 through 20 AWG. The strain relief assemblies will accommodate cable having with an insulation diameter range of 0.89 through 2.39 [.035 through .110]. Proper strip length is necessary to properly solder the wire onto the contact. The strip length of the wire is shown in Figure 2.

**CAUTION** Reasonable care must be taken not to nick, scrape, or cut any part of the wire during the stripping operation.

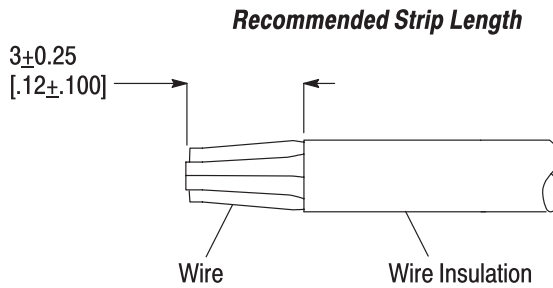



Figure 2

**3.5. Circuit Identification**

The contact cavities of the connectors are marked on the mating face and wire end of the connectors as shown in Figure 3.

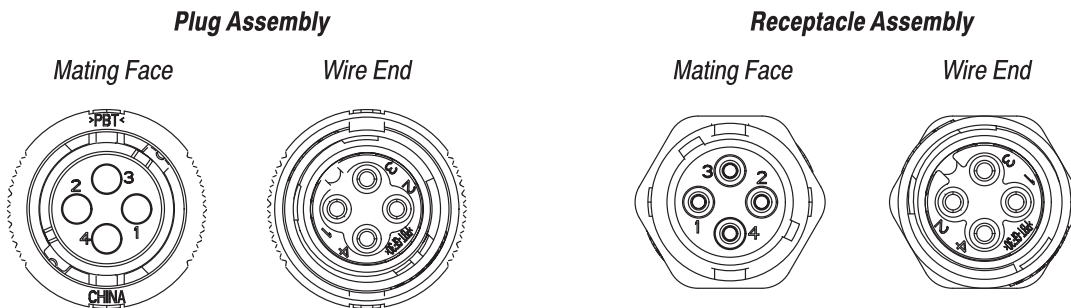

Figure 3

### 3.6. Soldering

Solder all wire leads to contacts according to the following:

1. The soldering surface must be clean and free of any contaminants.
2. Wire lead and interior of the contact solder cup must be fluxed prior to soldering using a mildly active rosin. Flux must be compatible with manufacturing, safety, and health guidelines.
3. The solder cup must be full with the solder contained inside the cup. Refer to Figure 4.
4. Soldered connections must be cleaned with a suitable alcohol-water rinse to remove flux and solder residue.

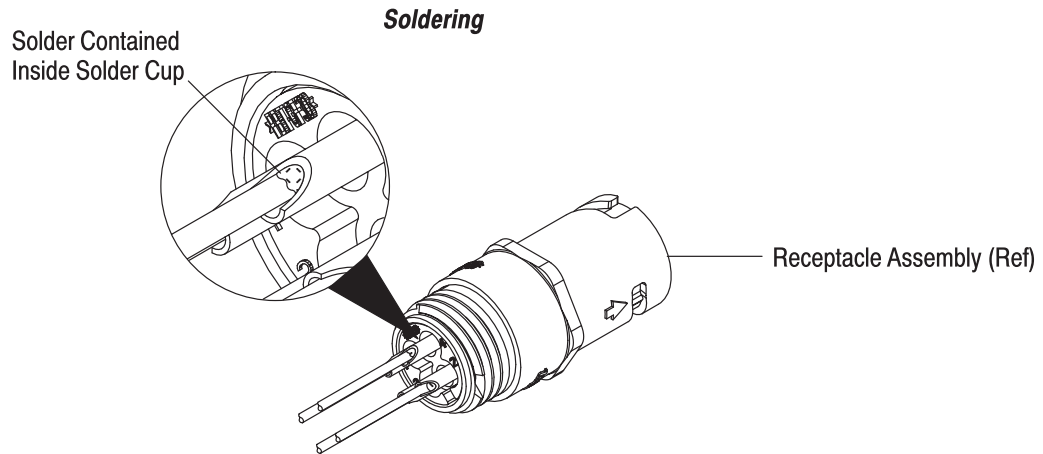

Figure 4

### 3.7. Strain Relief and Wire Dress

When bending or forming wires, hold the wire bundle at least 6.35 [.250] beyond the back of the housing before bending in any direction. Wires must remain perpendicular to the connector and avoid an excessively sharp bend radius.

If the wires are subject to strain, the strain relief assembly should be used to prevent damage to the wires, contacts, and housing. The strain relief must be slid over the wires and threaded onto the connector. The clamp must be pressed into either slot at the rear of the strain relief until it locks into place. The clamping area is adjustable from 0.76 mm<sup>2</sup> to 15.8 mm<sup>2</sup>. Pliers can be used to press the clamp into the desired clamping position. Refer to Figure 5.

**NOTE**

*The strain relief assembly includes two clamps: one small and one large. The small clamp must be used for these connectors.*

### Installing Strain Relief Assembly

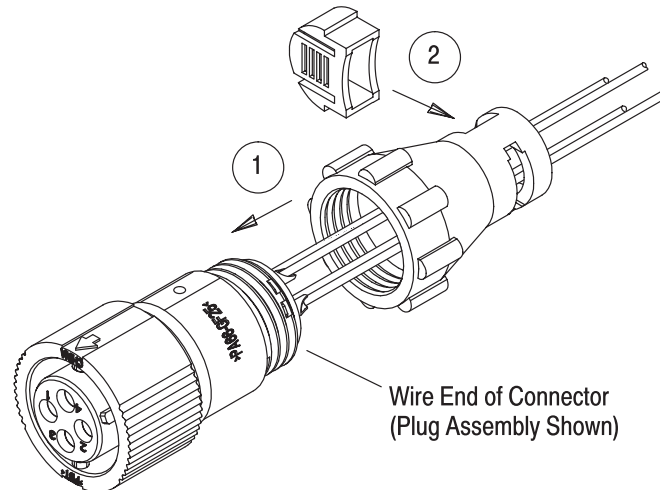

Figure 5

### A. Mating Dimension

The dimension needed to ensure full mating of connectors must be considered when determining location. The mated dimension of the connectors is provided in Figure 6.

### Mating Dimension

**Note:** Connectors are shown without strain relief.

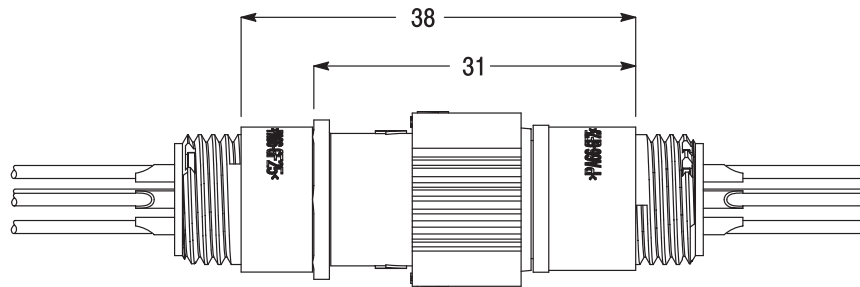

Figure 6

### 3.8. Mating



Connectors should be handled only by the housing to avoid deformation, contamination, or damage to the contact solder joints.

1. The mating faces of the receptacle assembly and plug assembly must face each other with the alignment dots aligned (the locking ring of the plug assembly can be rotated to align the second dot). Refer to Figure 7.
2. The mating face of the receptacle assembly must be inserted into the mating face of the plug assembly, then the locking ring must be rotated until the positive lock indicators (arrows) align.

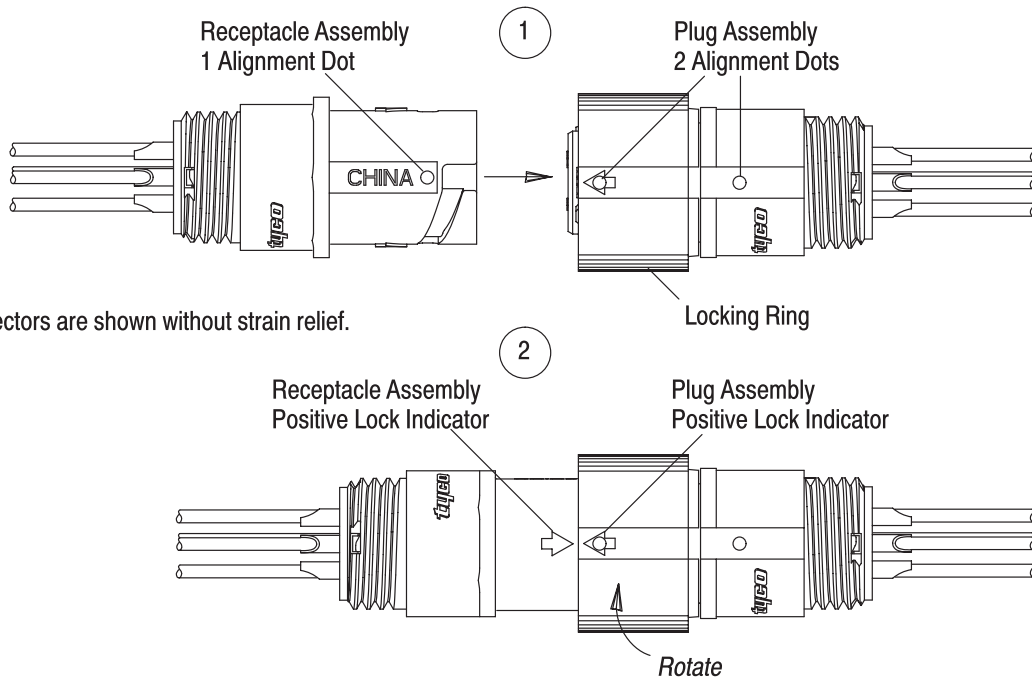
**Mating Alignment**

**Note:** Connectors are shown without strain relief.

Figure 7

### 3.9. Disassembly

The connectors must be unmated by rotating the locking ring until the connectors disconnect, align the alignment dots, then pull the connectors straight apart. To avoid damage to the soldered connections, DO NOT pull the wires.

### 3.10. Repair

These products are not repairable. Defective or damaged components must not be used. A terminated component must not be re-used by removing the wires.

## 4. QUALIFICATION

Spring probe miniature CPCs do not require agency approval.

## 5. TOOLING

No tooling is required for assembly or application of these connectors.

## 6. VISUAL AID

The illustration below shows a typical application of spring probe miniature CPCs. This illustration should be used by production personnel to ensure a correctly applied product. Applications which DO NOT appear correct should be inspected using the information in the preceding pages of this specification.

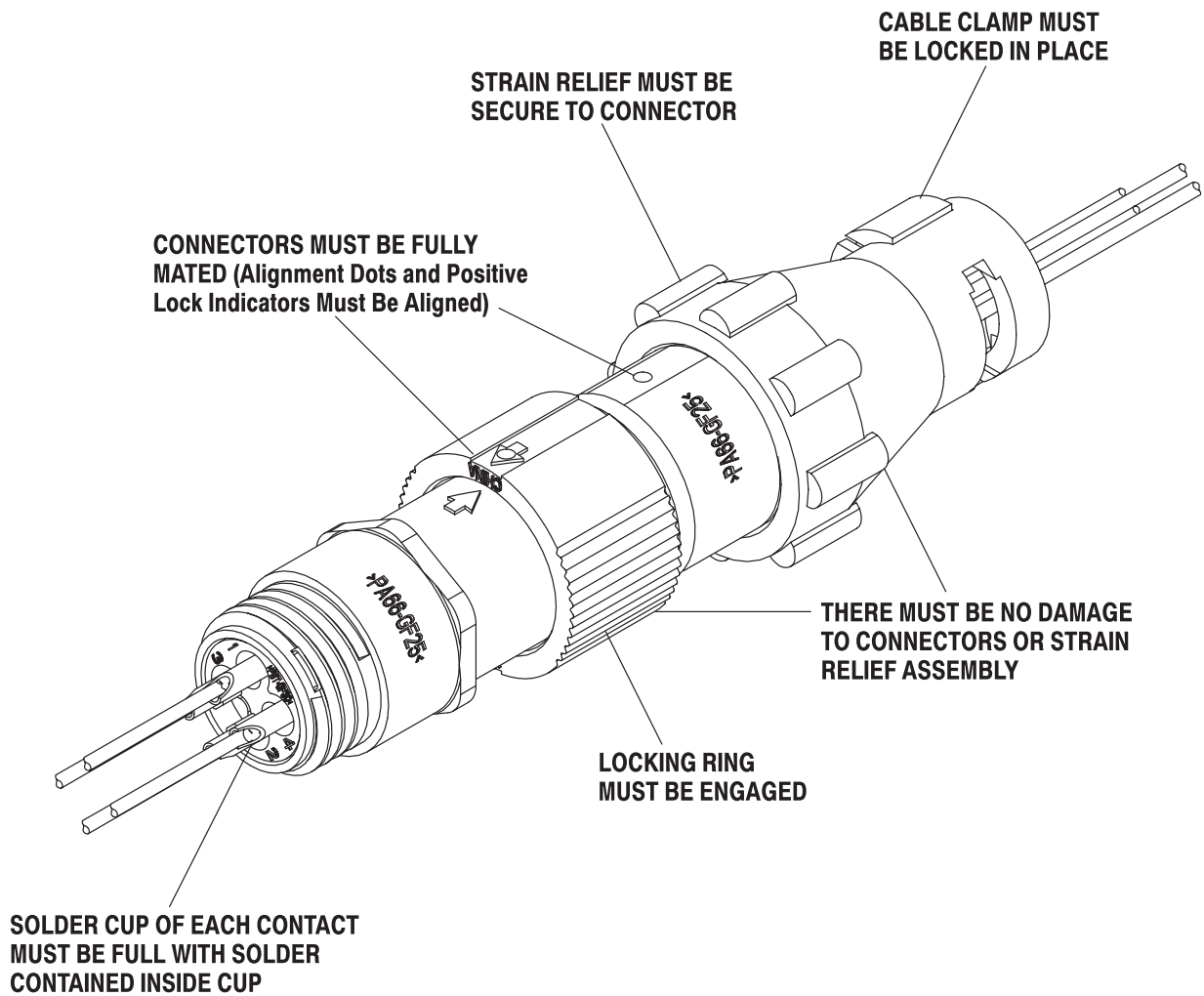

**FIGURE 8. VISUAL AID**

Компания «Life Electronics» занимается поставками электронных компонентов импортного и отечественного производства от производителей и со складов крупных дистрибьюторов Европы, Америки и Азии.

С конца 2013 года компания активно расширяет линейку поставок компонентов по направлению коаксиальный кабель, кварцевые генераторы и конденсаторы (керамические, пленочные, электролитические), за счёт заключения дистрибьюторских договоров

Мы предлагаем:

- Конкурентоспособные цены и скидки постоянным клиентам.
- Специальные условия для постоянных клиентов.
- Подбор аналогов.
- Поставку компонентов в любых объемах, удовлетворяющих вашим потребностям.
- Приемлемые сроки поставки, возможна ускоренная поставка.
- Доставку товара в любую точку России и стран СНГ.
- Комплексную поставку.
- Работу по проектам и поставку образцов.
- Формирование склада под заказчика.
- Сертификаты соответствия на поставляемую продукцию (по желанию клиента).
- Тестирование поставляемой продукции.
- Поставку компонентов, требующих военную и космическую приемку.
- Входной контроль качества.
- Наличие сертификата ISO.

В составе нашей компании организован Конструкторский отдел, призванный помогать разработчикам, и инженерам.

Конструкторский отдел помогает осуществить:

- Регистрацию проекта у производителя компонентов.
- Техническую поддержку проекта.
- Защиту от снятия компонента с производства.
- Оценку стоимости проекта по компонентам.
- Изготовление тестовой платы монтаж и пусконаладочные работы.



Тел: +7 (812) 336 43 04 (многоканальный)

Email: [org@lifeelectronics.ru](mailto:org@lifeelectronics.ru)